

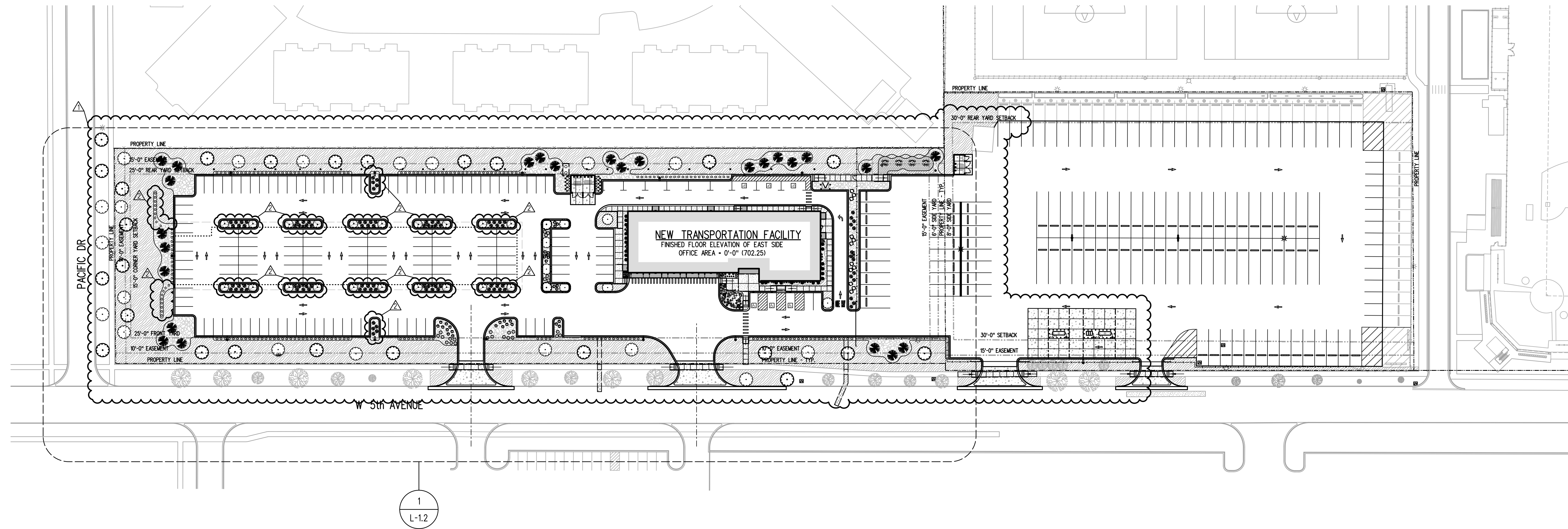

**HEALY  
BENDER  
PATTON  
& BEEN**  
ARCHITECTS

4040 Helene Avenue  
Naperville, IL 60564  
T 630.904.4300  
www.healybender.com



COMPOSITE LANDSCAPE / PRESERVATION PLAN

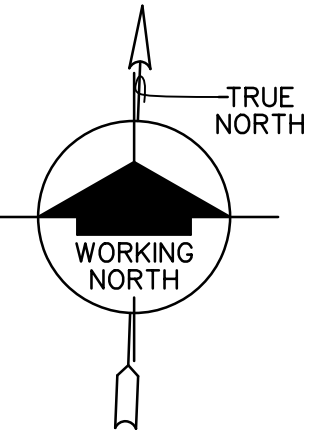

SITE INFORMATION OBTAINED FROM BOUNDARY SURVEY PREPARED BY:  
JLH LAND SURVEYING INC.  
910 GENEVA STREET  
SHOREWOOD, ILLINOIS 60404  
(815) 729-4000  
DATED: 09-23-2025

PLANT LIST					
SYMBOL	SCIENTIFIC NAME	COMMON NAME	QUANTITIES	SIZE	REMARKS
<b>TREES</b>					
AR	ACER RUBRUM	RED MAPLE	26	2 1/2" DIA. - 4' HIGH	B & B
GTI	GLEDTISIA TRIACANTHOS VAR. INERMIS	SKYLINE HONEYLOCUST	27	2 1/2" DIA. - 4' HIGH	B & B
PP	PICEA PUNGENS	COLORADO BLUE SPRUCE	25	2 1/2" DIA. - 4' HIGH	B & B
SR	SYRINGA RETICULATA 'IVORY SILK'	JAPANESE TREE LILAC	20	4' HIGH	B & B
TOS	THUJA OCCIDENTALIS 'SMARAGO'	EMERALD ARBORVITAE	23	4' HIGH	B & B
<b>SHRUBS</b>					
AT	ASCLEPIAS TUBEROSA	BUTTERFLY WEED	15	2' HIGH	B & B
BGM	BUXUS x 'GREEN MOUNTAIN'	GREEN MOUNTAIN BOXWOOD	216	1' HIGH	B & B
EA	EUONYMUS ALATUS	BURNING BUSH - FIRE BALL SEEDLESS	12	2' HIGH	B & B
FG	FESTUCA GLAUCA	FESCUE ELIJAH BLUE	36	2' HIGH	B & B
JS	JUNIPERUS SQAMATA	LITTLE BLUE STAR	18	1' HIGH	B & B
RH	RUDBECKIA HIRTA	BLACK EYED SUSAN	37	2' HIGH	B & B
SBC	SPIREA X BUMALDA 'GOLDFLAME'	GOLDFLAME SPIREA	2	2' HIGH	B & B
SH	SPOROBOLUS HETEROLEPIS	PRAIRIE DROPSEED	97	2' HIGH	B & B
SNP	STIPA (NASSELLA) 'PONYTAILS'	MEXICAN FEATHERGRASS	30	2' HIGH	B & B

**LEGEND**

- AREA TO BE RESTORED WITH MINIMUM 9" DEPTH OF TOPSOIL, FERTILIZER, AND SOD AS SPECIFIED - PROVIDE FLUSH CONDITION WITH ADJACENT GRADES
- MULCH
- NEW MULCH ON 9" MIN. TOPSOIL - PROVIDE FLUSH CONDITION WITH ADJACENT GRADES
- BRICK PAVERS
- CONCRETE PAVING - SEE CIVIL DRAWINGS
- CONCRETE WALKS & CURBS, UON - SEE CIVIL DRAWINGS
- CONCRETE STOOPS - SEE STRUCTURAL DRAWINGS
- EXISTING TREES & SHRUBS TO REMAIN
- TREES & SHRUBS - SEE PLANT LIST THIS SHEET
- NEW 8'-0" HIGH CHAIN LINK FENCE - VINYL BLACK COATED
- EXISTING 8'-0" HIGH CHAIN LINK FENCE TO REMAIN - VINYL BLACK COATED
- EXISTING 6'-0" HIGH WOOD SLAT FENCE TO REMAIN

PLANTING NOTES

- THE CONTRACTOR SHALL PROVIDE AND INSTALL ALL PLANT MATERIAL IN QUANTITIES SUFFICIENT TO COMPLETE THE PLANTING SHOWN ON THE DRAWING. ALL PLANTS SHALL COMPLY WITH THE REQUIREMENTS OF THE CURRENT AMERICAN STANDARD FOR NURSERY STOCK, PUBLISHED BY THE AMERICAN ASSOCIATION OF NURSERYMEN, LATEST EDITION. PLANTS SHALL MEET SIZE, GENUS, SPECIES AND VARIETY. PLANTS SHALL BE IN GOOD HEALTH, FREE OF DISEASE, INSECTS, AND DEFECTS. NO "PARK GRADE" MATERIAL SHALL BE ACCEPTED. PLANTS MAY BE SUBSTITUTED UPON THE APPROVAL OF THE GOVERNING MUNICIPALITY.
- PLANTS SHALL BE BALLED AND BURLAPPED OR CONTAINER GROWN. NO ROOT BOUND MATERIAL SHALL BE ACCEPTED AND ALL WRAPPING MATERIAL MADE OF SYNTHETICS OR PLASTICS SHALL BE REMOVED AT THE TIME OF PLANTING. CONTRACTOR SHALL REMOVE BURLAP FROM TOP ONE THIRD OF BALL AT THE TIME OF PLANTING.
- ALL PLANTS SHALL BE THOROUGHLY WATERED IMMEDIATELY UPON COMPLETION OF BACKFILLING AND BEFORE STAKING OR MULCHING. CONTRACTOR IS RESPONSIBLE FOR WATERING SOD THE SAME DAY IT IS LAID. SUFFICIENT WATER SHALL BE APPLIED TO WET THE SOD THROUGH COMPLETELY AND AT LEAST 2" OF THE SOD BED AS WELL. CONTRACTOR SHALL WATER THE NEWLY SODDED AREAS SUFFICIENTLY IN A MANNER WHICH WILL PREVENT EROSION DUE TO APPLICATION OF EXCESSIVE QUANTITIES OF WATER.
- ALL SHRUB AND LANDSCAPING BEDS SHALL RECEIVE 4" DEPTH OF WOOD FIBER MULCH ON WEED CONTROL FABRIC, UNLESS OTHERWISE NOTED.
- ALL PLANTS SHALL BE SET PLUMB. CONTRACTOR TO ENSURE PLANTS REMAIN PLUMB UNTIL THE END OF THE GUARANTEE PERIOD.
- PROVIDE SOD AND FERTILIZER IN ALL AREAS AFFECTED BY CONSTRUCTION ACTIVITIES UNLESS OTHERWISE INDICATED.
- PRUNE, THIN OUT, AND SHAPE NEW PLANTS IN ACCORDANCE WITH STANDARD HORTICULTURAL PRACTICES TO RETAIN THEIR NATURAL CHARACTER. REMOVE ANY INJURED, DAMAGED, DEAD OR CROSSED BRANCHES FROM THE PLANT AT TIME OF INSTALLATION.
- AREAS OF GROUND COVER GROUPINGS SHALL RECEIVE A 6" DEPTH OF ORGANIC COMPOST IN ADDITION TO A 2" DEPTH TOPPING OF WOOD FIBER MULCH.
- THE CONTRACTOR SHALL VERIFY THE EXTENT OF ALL EXISTING UNDERGROUND UTILITIES PRIOR TO STARTING. THE CONTRACTOR MUST ALSO KEEP THE PAVEMENT AND WORK AREA IN A NEAT AND ORDERLY CONDITION THROUGHOUT THE INSTALLATION PROCESS.
- SOD SHALL EXTEND TO ALL CONCRETE WALKS, UNLESS OTHERWISE NOTED.
- ALL EDGING TO BE SPADED NATURAL EDGE, NO STEEL OR PLASTIC EDGING SHALL BE USED.
- CONTRACTOR SHALL PROTECT ALL EXISTING TREES WHICH ARE TO REMAIN AND ARE SUBJECT TO CONSTRUCTION DAMAGE. THE METHOD OF PROTECTION SHALL BE AS REQUIRED TO ELIMINATE CONSTRUCTION ACTIVITIES FROM OCCURRING WITHIN THE CRITICAL ROOT ZONE, WHICH IS DEFINED AS THE ENTIRE GROUND AREA THAT LIES WITHIN AND OUT TO THE END OF THE DRIP LINE OF THE TREE.
- WHEN POSSIBLE, THE ENTIRE CRITICAL ROOT ZONE OF THE TREE MUST BE FENCED. ONCE ASSEMBLED, NO FENCING OR OTHER PROTECTION DEVICE SHALL BE REMOVED WITHOUT PRIOR APPROVAL OF THE HEAD OF BUILDING OPERATIONS. NO CONSTRUCTION ACTIVITY OR MATERIAL SHALL BE PERMITTED WITHIN THE FENCE ENCLOSURE.
- THE CONTRACTOR SHALL PERFORM PRE-CONSTRUCTION ROOT PRUNING. ROOT PRUNING SHALL BE PERFORMED BY A ROOT PRUNING SAW TO MAKE A CLEAN CUT OF THE ROOTS. THE ROOT PRUNING LINE SHALL BE LOCATED SIX INCHES TO THE INSIDE OF THE TRENCH OR EXCAVATION AND SHALL BE PERFORMED PRIOR TO THE TRENCH BEING DUG. AT LOCATIONS OF ROOT PRUNING, BACKFILLING SHALL OCCUR AS SOON AS POSSIBLE. WHILE THE ROOTS ARE OPEN TO THE EXCAVATION, THE ROOTS SHALL BE KEPT MOIST BY WATERING PROCEDURES.

NEW TRANSPORTATION FACILITY  
NAPERVILLE COMMUNITY UNIT SCHOOL DISTRICT 203  
NAPERVILLE, ILLINOIS

FOR  
NAPERVILLE COMMUNITY UNIT SCHOOL DISTRICT 203  
NAPERVILLE, DUPAGE COUNTY, ILLINOIS

REVISIONS	NO.	DATE	DESCRIPTION
	1	01-23-2025	CITY OF NAPERVILLE COMMENTS
	2	02-25-2025	CITY OF NAPERVILLE COMMENTS
PROJ. NO.	5-2325-34		
DRAWN BY	LCB, MSJ, STMP		
DATE	11-24-2025		
SHEET NO.	L-1.1		
OF 3			



**HEALY  
BENDER  
PATTON  
& BEEN**  
ARCHITECTS

4040 Helene Avenue  
Naperville, IL 60564  
T 630.904.4300  
www.healybender.com

**NEW TRANSPORTATION FACILITY  
NAPERVILLE COMMUNITY UNIT SCHOOL DISTRICT 203**  
FOR  
NAPERVILLE COMMUNITY UNIT SCHOOL DISTRICT 203  
NAPERVILLE, DUPAGE COUNTY, ILLINOIS

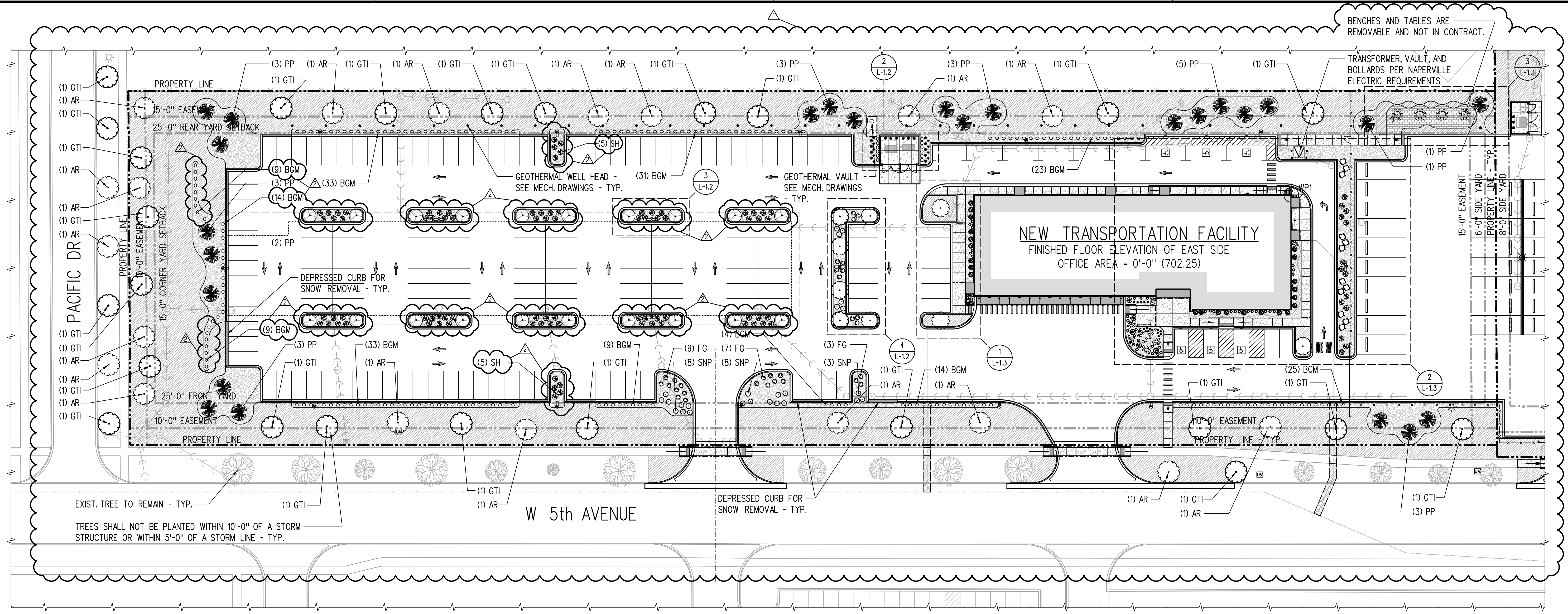

**1 ENLARGED LANDSCAPE PLAN - UPPER LOT**  
L-1.2  
1" = 30'-0"  
0 15 30 60 90

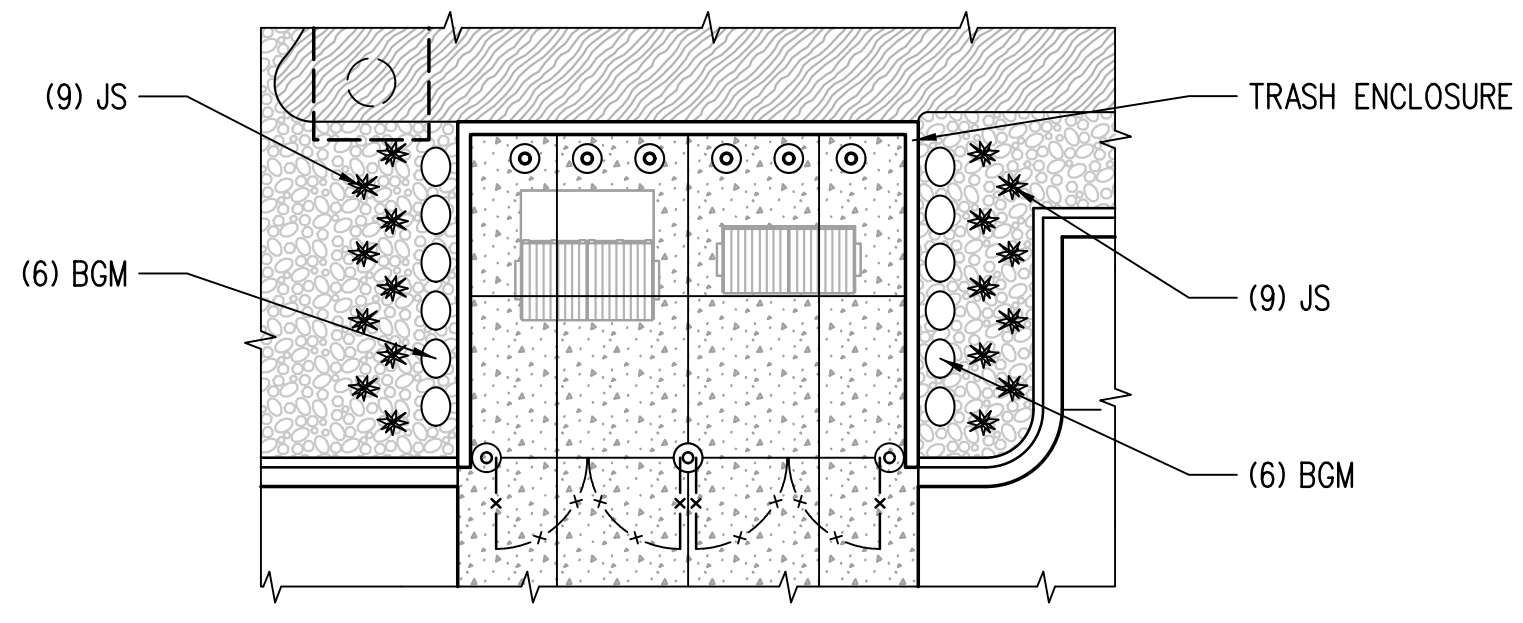
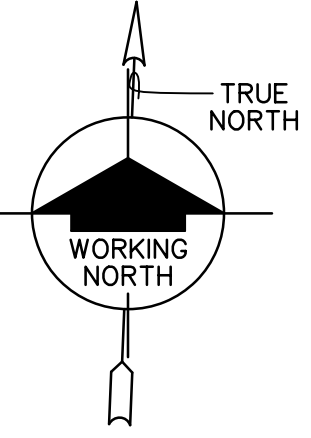

**2 PARTIAL ENLARGED LANDSCAPING PLAN**  
L-1.2  
1" = 10'-0"  
0 5 10 20 30

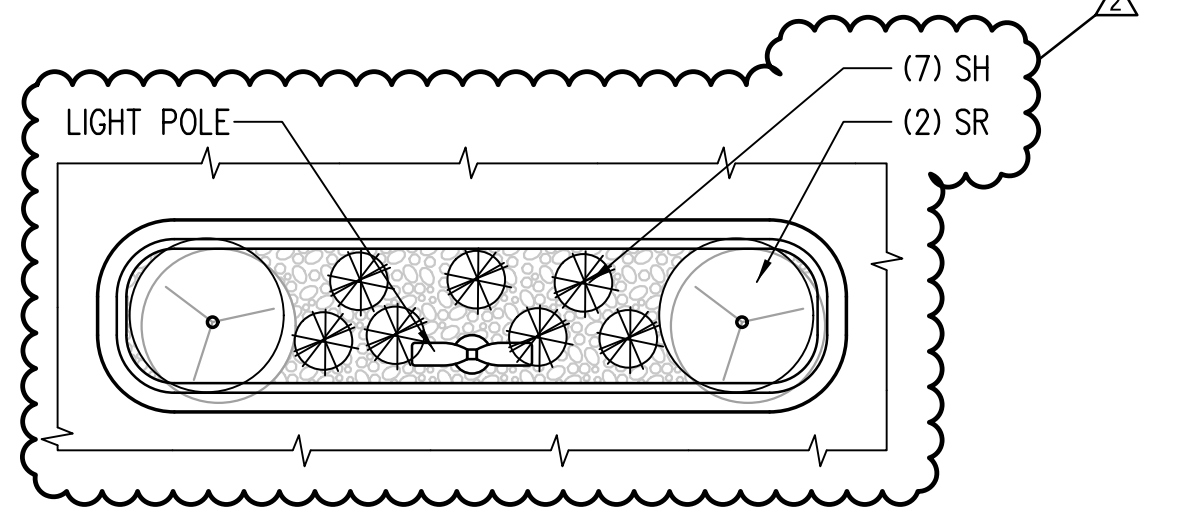
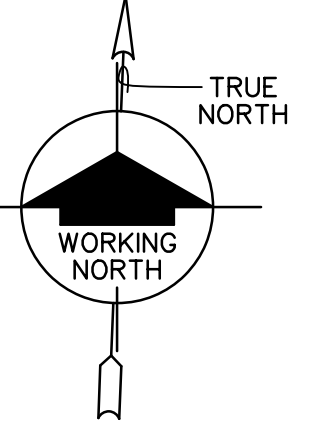

**3 TYPICAL PARKING LOT ISLAND  
PARTIAL ENLARGED LANDSCAPING PLAN**  
L-1.2  
1" = 10'-0"

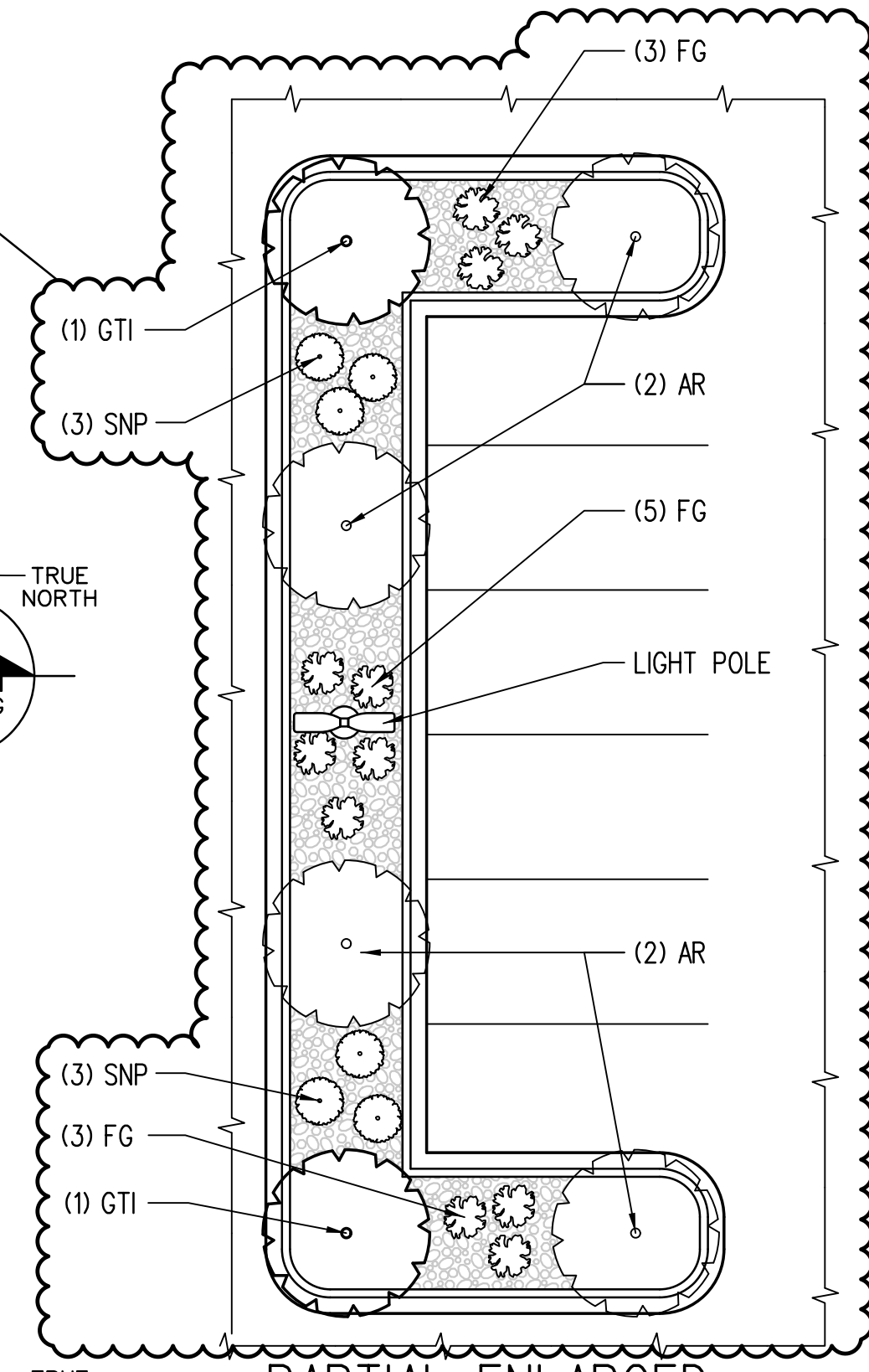
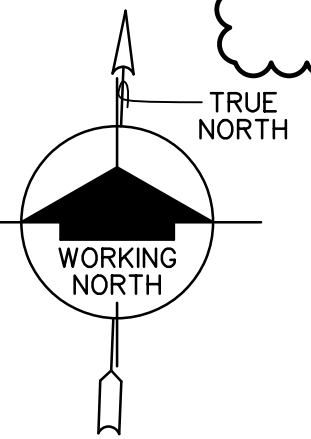

**4 PARTIAL ENLARGED  
LANDSCAPING PLAN**  
L-1.2  
1" = 10'-0"

**LEGEND**

- AREA TO BE RESTORED WITH MINIMUM 9" DEPTH OF TOPSOIL, FERTILIZER, AND SOD AS SPECIFIED - PROVIDE FLUSH CONDITION WITH ADJACENT GRADES
- MULCH
- NEW MULCH ON 9" MIN. TOPSOIL - PROVIDE FLUSH CONDITION WITH ADJACENT GRADES
- BRICK PAVERS
- CONCRETE PAVING - SEE CIVIL DRAWINGS
- CONCRETE WALKS & CURBS, UON - SEE CIVIL DRAWINGS
- CONCRETE STOOPS - SEE STRUCTURAL DRAWINGS
- EXISTING TREES & SHRUBS TO REMAIN
- TREES & SHRUBS - SEE PLANT LIST THIS SHEET
- NEW 8'-0" HIGH CHAIN LINK FENCE - VINYL BLACK COATED
- EXISTING 8'-0" HIGH CHAIN LINK FENCE TO REMAIN - VINYL BLACK COATED
- EXISTING 6'-0" HIGH WOOD SLAT FENCE TO REMAIN

PLANT LIST					
SYMBOL	SCIENTIFIC NAME	COMMON NAME	QUANTITIES	SIZE	REMARKS
<b>TREES</b>					
AR	ACER RUBRUM	RED MAPLE	26	2 1/2" DIA. - 4' HIGH	B & B
GTI	GLEDITSIA TRIACANTHOS VAR. INERMIS	SKYLINE HONEYLOCUST	27	2 1/2" DIA. - 4' HIGH	B & B
PP	PICEA PLUNGENS	COLORADO BLUE SPRUCE	25	2 1/2" DIA. - 4' HIGH	B & B
SR	SYRINGA RETICULATA 'IVORY SILK'	JAPANESE TREE LILAC	20	4' HIGH	B & B
TOS	TRUJA OCCIDENTALIS 'SMARAGD'	EMERALD ARBORVITAE	23	4' HIGH	B & B
<b>SHRUBS</b>					
AT	ASCLEPIAS TUBEROSA	BUTTERFLY WEED	15	2' HIGH	B & B
BGM	BUXUS x 'GREEN MOUNTAIN'	GREEN MOUNTAIN BOXWOOD	26	4' HIGH	B & B
EA	EUONYMUS ALATUS	BURNING BUSH - FIRE BALL SEEDLESS	15	2' HIGH	B & B
FG	FESTUCA GLAUCA	FESCUE ELIJAH BLUE	36	2' HIGH	B & B
JS	JUNIPERUS SQUMAMATA	LITTLE BLUE STAR	18	1' HIGH	B & B
RH	RUDBECKIA HIRTA	BLACK EYED SUSAN	37	2' HIGH	B & B
SBG	SPIRECA x BUMALDA 'GOLDFLAME'	GOLDFLAME SPIRECA	2	2' HIGH	B & B
SH	SPOROBOLUS HETEROLEPIS	PRAIRIE DROPS EED	97	2' HIGH	B & B
SNP	STIPA (NASSELLA) 'PONYTAILS'	MEXICAN FEATHERGRASS	30	2' HIGH	B & B

**REVISIONS**

NO.	DATE	DESCRIPTION
1	01-23-2025	CITY OF NAPERVILLE COMMENTS
2	02-25-2025	CITY OF NAPERVILLE COMMENTS

PROJ. NO. 5-2325-34  
DRAWN BY LCB, MSJ, STMP  
DATE 11-24-2025  
SHEET NO. **L-1.2**  
OF 3

ENLARGED LANDSCAPING PLAN - UPPER LOT, PARTIAL ENLARGED LANDSCAPING PLANS  
COPYRIGHT © 2025 HEALY BENDER PATTON & BEEN ARCHITECTS

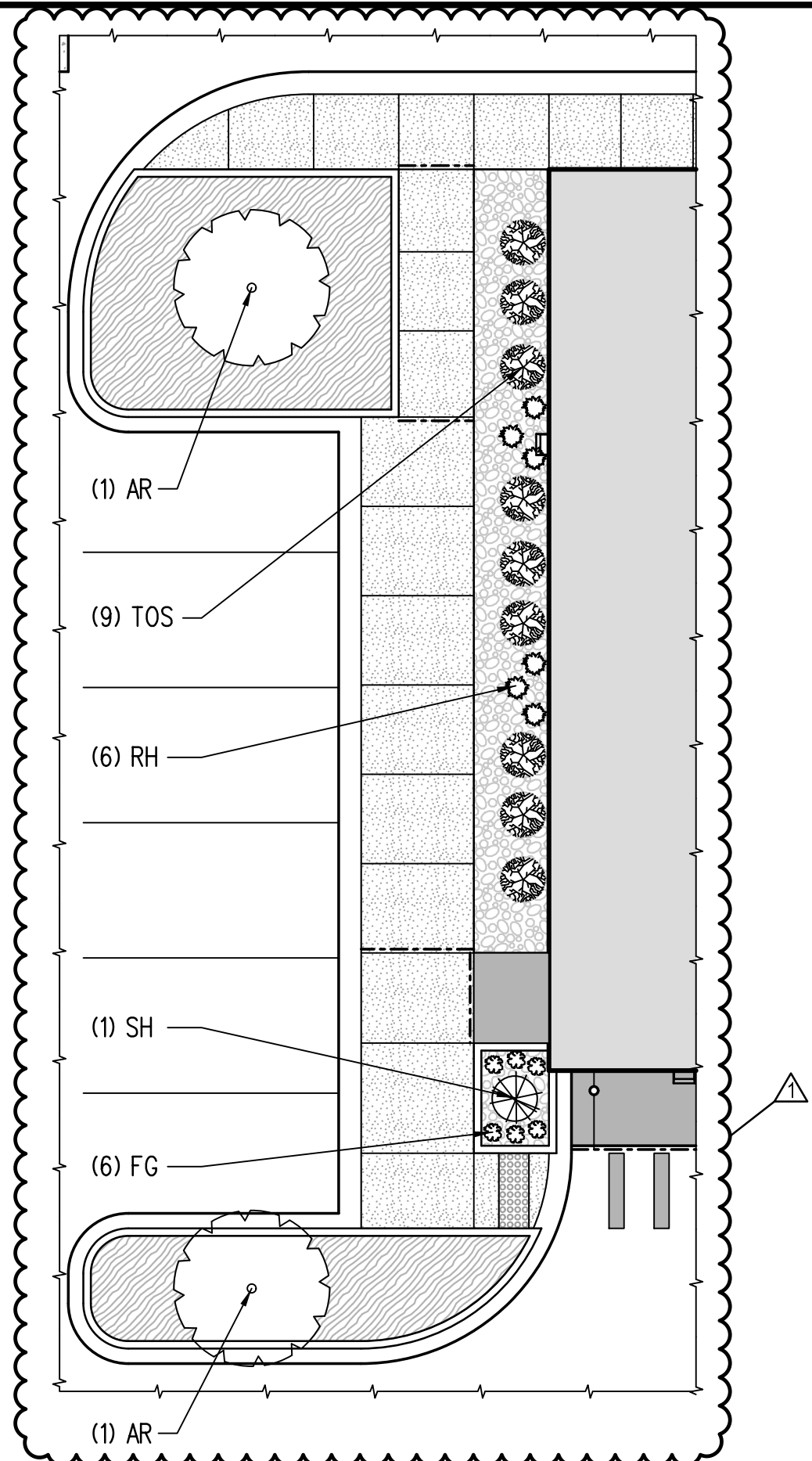

1 PARTIAL ENLARGED LANDSCAPING PLAN

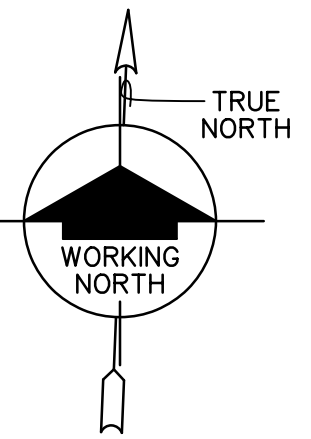

- LEGEND**
- AREA TO BE RESTORED WITH MINIMUM 9" DEPTH OF TOPSOIL, FERTILIZER, AND SOD AS SPECIFIED - PROVIDE FLUSH CONDITION WITH ADJACENT GRADES
  - MULCH
  - NEW MULCH ON 9" MIN. TOPSOIL - PROVIDE FLUSH CONDITION WITH ADJACENT GRADES
  - BRICK PAVERS
  - CONCRETE WALKS & CURBS, UON - SEE CIVIL DRAWINGS
  - CONCRETE STOOPS - SEE STRUCTURAL DRAWINGS
  - EXISTING TREES & SHRUBS TO REMAIN
  - TREES & SHRUBS - SEE PLANT LIST THIS SHEET
  - NEW 8'-0" HIGH CHAIN LINK FENCE - VINYL BLACK COATED

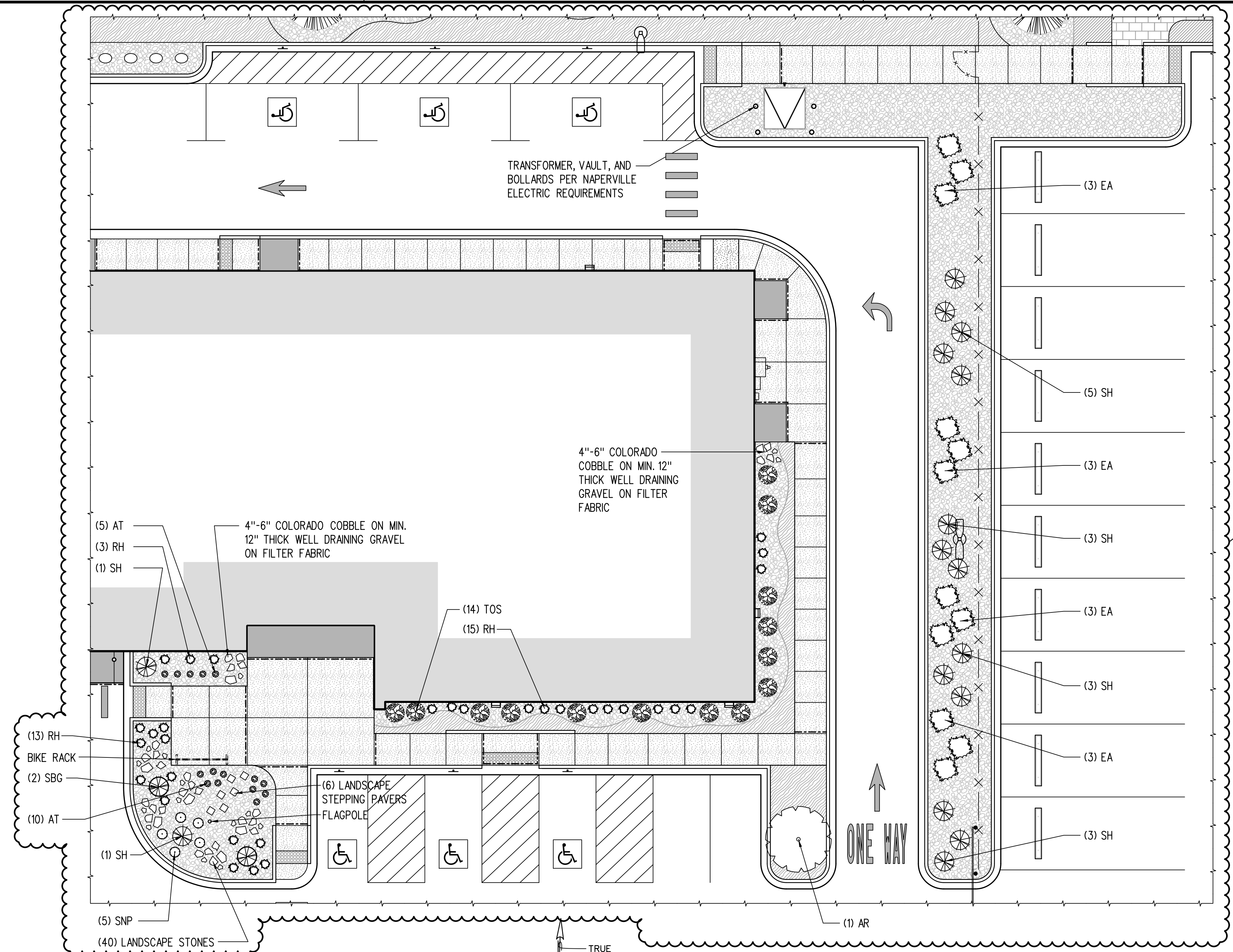

2 PARTIAL ENLARGED LANDSCAPING PLAN

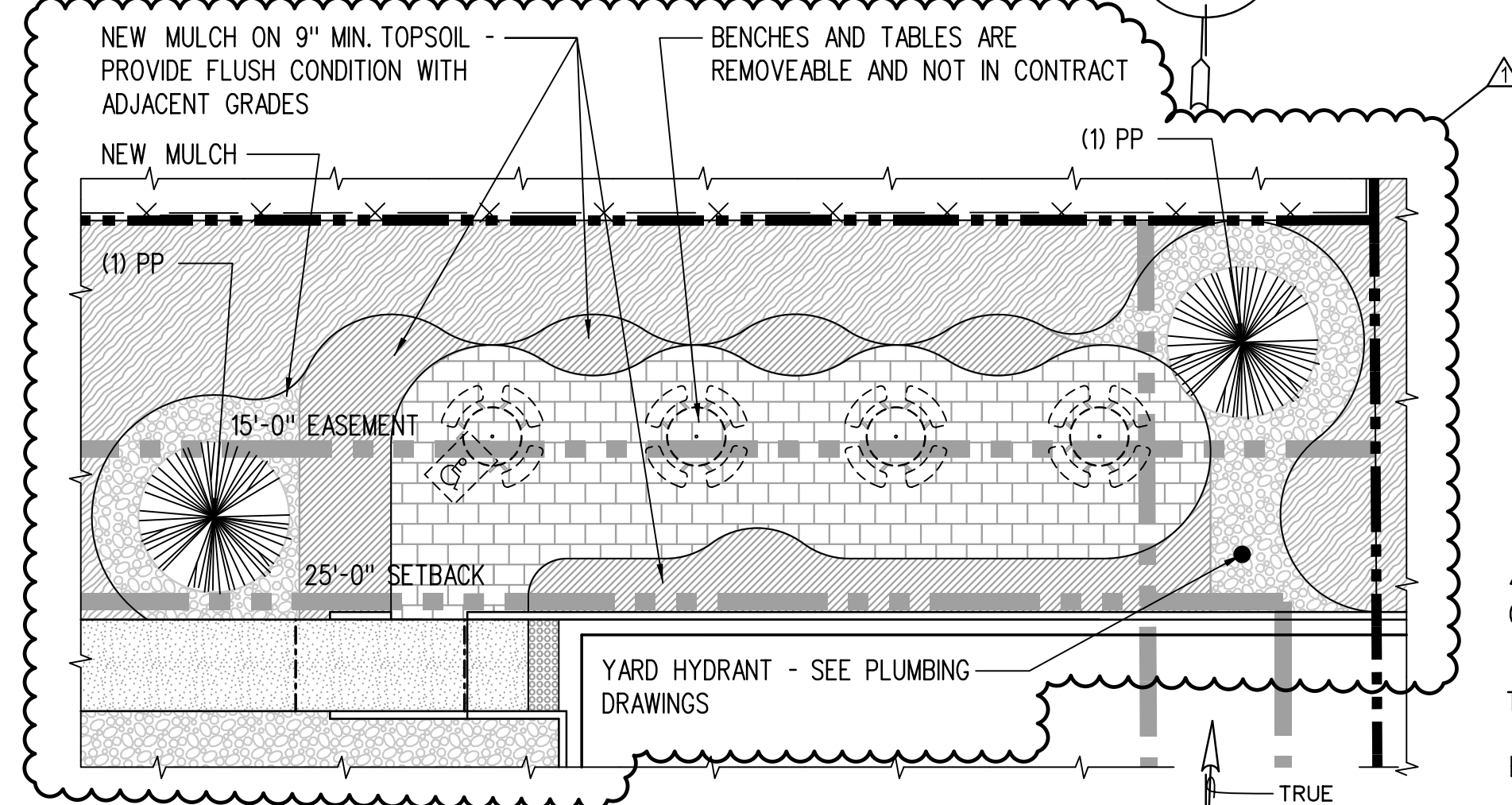
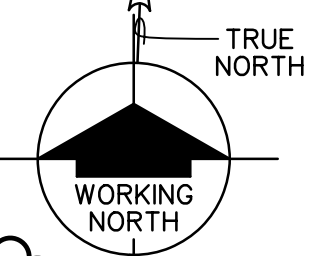
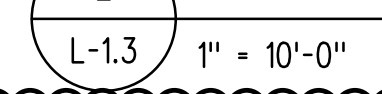

3 PARTIAL ENLARGED LANDSCAPING PLAN

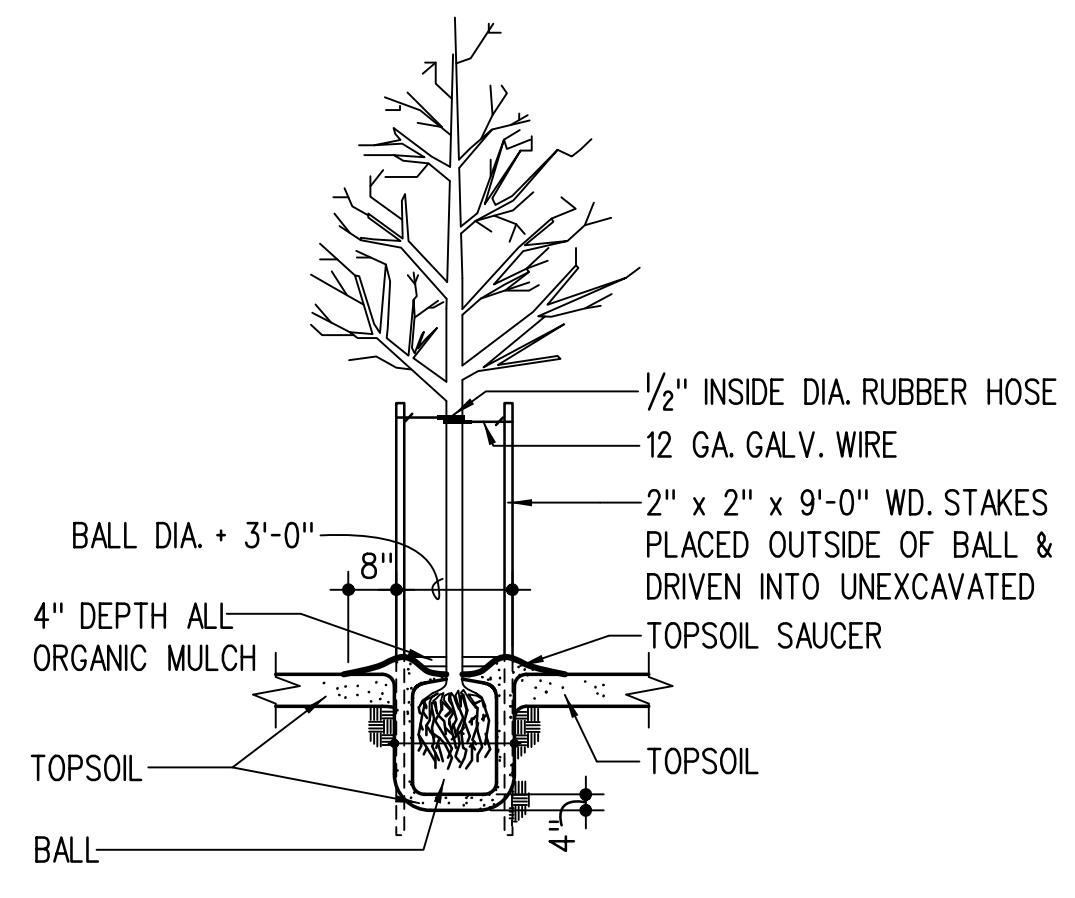
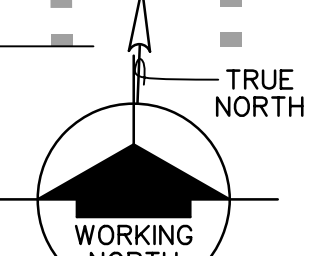
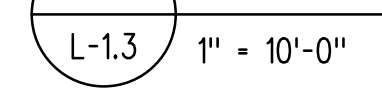

4 TYP. TREE STAKING

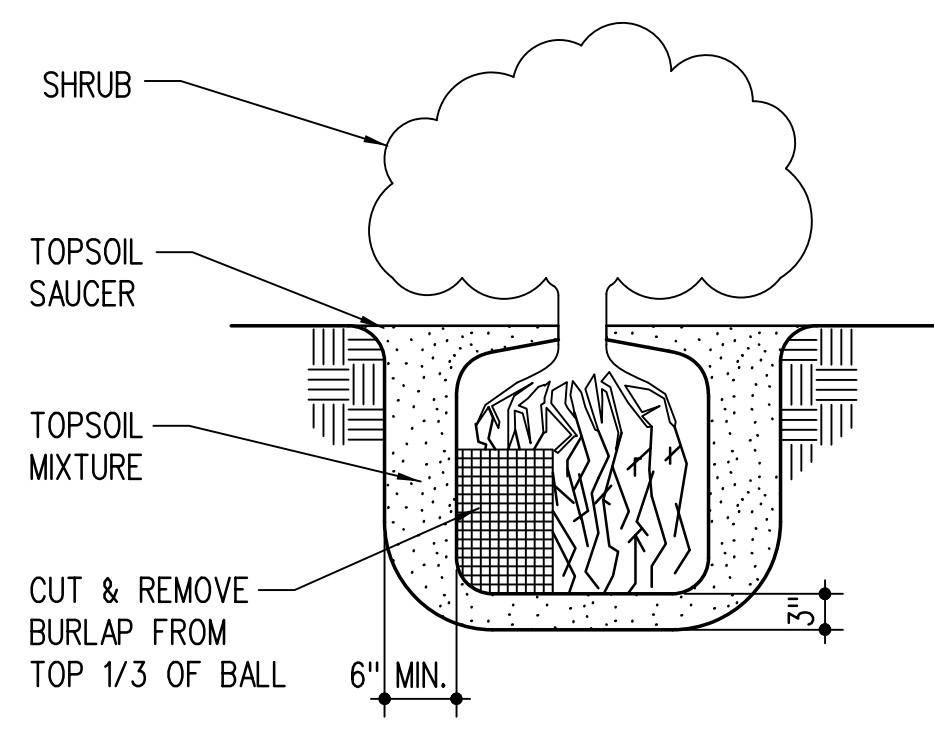

5 TYP. SHRUB PLANTING

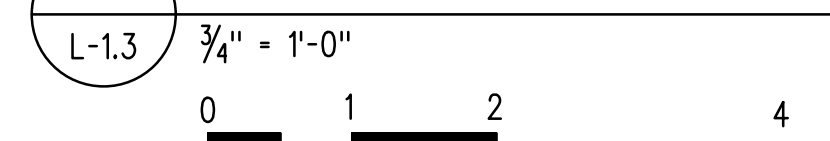

PLANT LIST					
SYMBOL	SCIENTIFIC NAME	COMMON NAME	QUANTITIES	SIZE	REMARKS
<b>TREES</b>					
AR	ACER RUBRUM	RED MAPLE	26	2 1/2" DIA. - 4' HIGH	B & B
GTI	GLEDITSIA TRIACANTHOS VAR. INERMIS	SKYLINE HONEYLOCUST	27	2 1/2" DIA. - 4' HIGH	B & B
PP	PICEA PUNGENS	COLORADO BLUE SPRUCE	25	2 1/2" DIA. - 4' HIGH	B & B
SR	SYRINGA RETICULATA 'IVORY SILK'	JAPANESE TREE LILAC	20	4' HIGH	B & B
TOS	THUJA OCCIDENTALIS 'SMARAGO'	EMERALD ARBORVITAE	23	4' HIGH	B & B
<b>SHRUBS</b>					
AT	ASCLEPIAS TUBEROSA	BUTTERFLY WEED	15	2' HIGH	B & B
BGM	BUXUS x 'GREEN MOUNTAIN'	GREEN MOUNTAIN BOXWOOD	216	1" HIGH	B & B
EA	EUONYMUS ALATUS	BURNING BUSH - FIRE BALL SEEDLESS	17	2' HIGH	B & B
FG	FESTUCA GLAUCA	FESCUE ELIJAH BLUE	36	2' HIGH	B & B
JS	JUNIPERUS SQUAMATA	LITTLE BLUE STAR	18	1" HIGH	B & B
RH	RUBRICKIA HIRTA	BLACK EYED SUSAN	37	2' HIGH	B & B
SBG	SPIREA x BUMALDA 'GOLDFLAME'	GOLDFLAME SPIREA	2	2' HIGH	B & B
SH	SPOROBOLUS HETEROLEPIS	PRAIRIE DROPSEED	97	2' HIGH	B & B
SNP	STIPA (NASSELLA) 'PONYTAILS'	MEXICAN FEATHERGRASS	30	2' HIGH	B & B

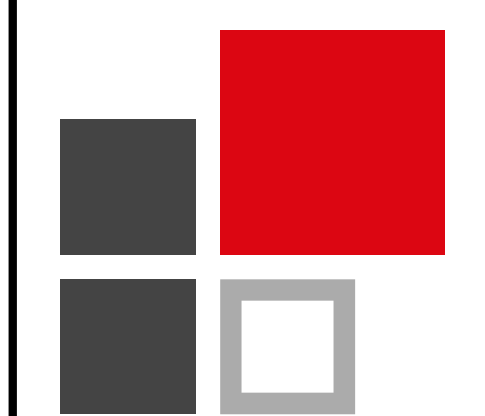

**HEALY  
BENDER  
PATTON  
& BEEN**  
ARCHITECTS  
4040 Helene Avenue  
Naperville, IL 60564  
T 630.904.4300  
www.healybender.com

**NEW TRANSPORTATION FACILITY  
NAPERVILLE COMMUNITY UNIT SCHOOL DISTRICT 203**  
FOR  
NAPERVILLE, ILLINOIS  
NAPERVILLE COMMUNITY UNIT SCHOOL DISTRICT 203  
NAPERVILLE, DU PAGE COUNTY, ILLINOIS

REVISIONS	NO.	DATE	DESCRIPTION
	1	01-23-2025	CITY OF NAPERVILLE COMMENTS
	2	02-25-2025	CITY OF NAPERVILLE COMMENTS

PROJ. NO. 5-2325-34  
DRAWN BY LCB, MSJ, STMP  
DATE 11-24-2025  
SHEET NO. **L-1.3**  
OF 3

PARTIAL ENLARGED LANDSCAPING PLANS, TYPICAL DETAILS  
COPYRIGHT © 2025 HEALY BENDER PATTON & BEEN ARCHITECTS