

# PRELIMINARY ENGINEERING PLAN FOR NAPERVILLE POLO CLUB

NAPERVILLE, IL

## LEGAL DESCRIPTION

**PARCEL 1:** THE EAST 329.36 FEET OF THE EAST 1/2 OF THE SOUTH 1/2 OF THE SOUTHEAST 1/4 OF SECTION 22, TOWNSHIP 37 NORTH, RANGE 9 EAST OF THE THIRD PRINCIPAL MERIDIAN IN WILL COUNTY ILLINOIS.  
**PARCEL 2:** THE WEST 329.36 FEET OF THE EAST 658.72 FEET OF THE EAST 1/2 OF THE SOUTH 1/2 OF THE SOUTHEAST 1/4 OF SECTION 22, TOWNSHIP 37 NORTH, RANGE 9 EAST OF THE THIRD PRINCIPAL MERIDIAN IN WILL COUNTY ILLINOIS.  
**PARCEL 3:** THE WEST 329.36 FEET OF THE EAST 988.08 FEET OF THE EAST 1/2 OF THE SOUTH 1/2 OF THE SOUTHEAST 1/4 OF SECTION 22, TOWNSHIP 37 NORTH, RANGE 9 EAST OF THE THIRD PRINCIPAL MERIDIAN IN WILL COUNTY ILLINOIS.  
**PARCEL 4:** THE EAST 1/2 OF THE SOUTH 1/2 OF THE SOUTHEAST 1/4 OF SECTION 22, TOWNSHIP 37 NORTH, RANGE 9 EAST OF THE THIRD PRINCIPAL MERIDIAN (EXCEPT THE EAST 988.08 FEET THEREOF) IN WILL COUNTY ILLINOIS.  
**PARCEL 5:** THE EAST 329.36 FEET OF THE WEST 1/2 OF THE SOUTH 1/2 OF THE SOUTHEAST 1/4 OF SECTION 22, TOWNSHIP 37 NORTH, RANGE 9 EAST OF THE THIRD PRINCIPAL MERIDIAN IN WILL COUNTY ILLINOIS.  
**PARCEL 6:** THE WEST 329.36 FEET OF THE EAST 658.72 FEET OF THE WEST 1/2 OF THE SOUTH 1/2 OF THE SOUTHEAST 1/4 OF SECTION 22, TOWNSHIP 37 NORTH, RANGE 9 EAST OF THE THIRD PRINCIPAL MERIDIAN IN WILL COUNTY ILLINOIS.  
**PARCEL 7:** THE WEST 329.36 FEET OF THE EAST 988.08 FEET OF THE WEST 1/2 OF THE SOUTH 1/2 OF THE SOUTHEAST 1/4 OF SECTION 22, TOWNSHIP 37 NORTH, RANGE 9 EAST OF THE THIRD PRINCIPAL MERIDIAN IN WILL COUNTY ILLINOIS.  
**PARCEL 8:** THE WEST 1/2 OF THE SOUTH 1/2 OF THE SOUTHEAST 1/4 OF SECTION 22, TOWNSHIP 37 NORTH, RANGE 9 EAST OF THE THIRD PRINCIPAL MERIDIAN (EXCEPT THE EAST 988.08 FEET THEREOF) IN WILL COUNTY ILLINOIS.  
**PARCEL 9:** THE SOUTHEAST 1/4 OF THE SOUTHWEST 1/4 OF SECTION 22, TOWNSHIP 37 NORTH, RANGE 9, EAST OF THE THIRD PRINCIPAL MERIDIAN (EXCEPT THE WEST 328.81 FEET THEREOF) IN WILL COUNTY, ILLINOIS.

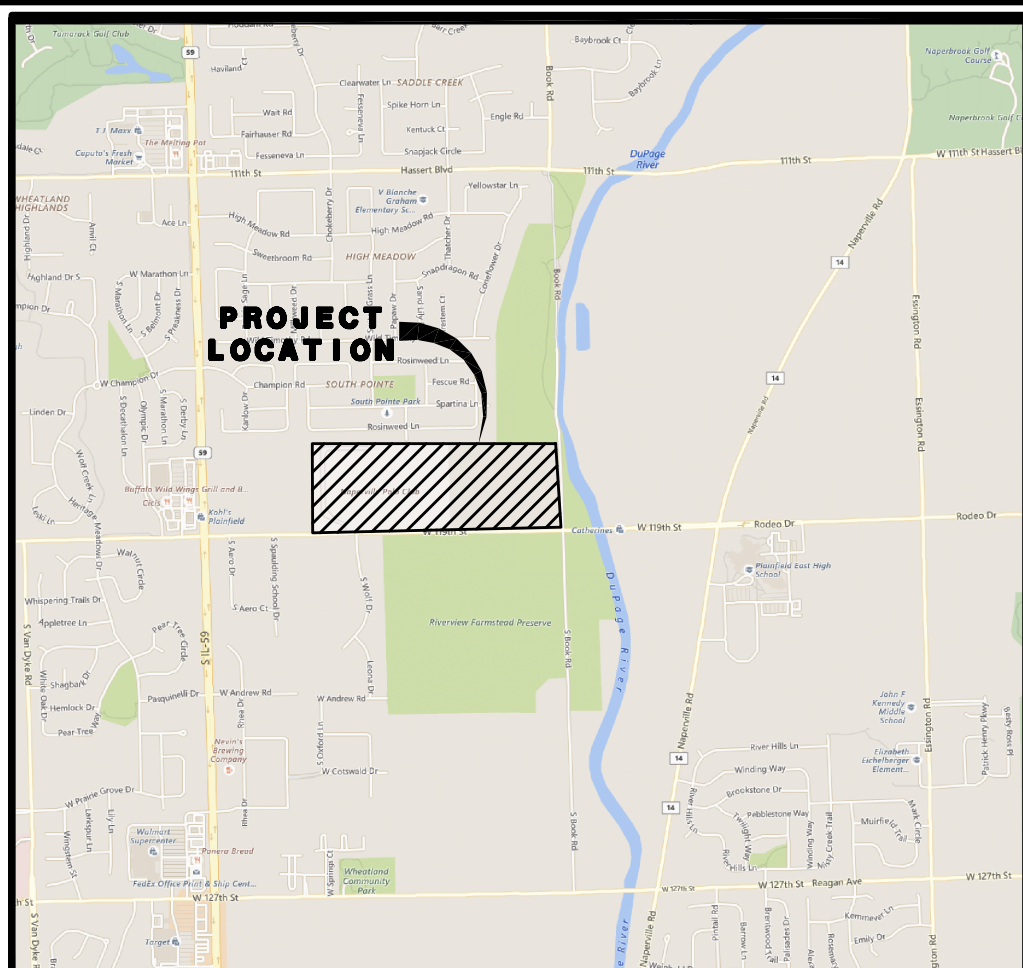

**LOCATION MAP**

**BUILDING PRODUCT TYPE SUMMARY:**  
 88 AGE TARGETED SINGLE FAMILY LOTS  
 93 AGE TARGETED RANCH TOWNHOME UNITS  
 50 TRADITIONAL SINGLE FAMILY LOTS  
 269 TRADITIONAL TOWNHOME UNITS

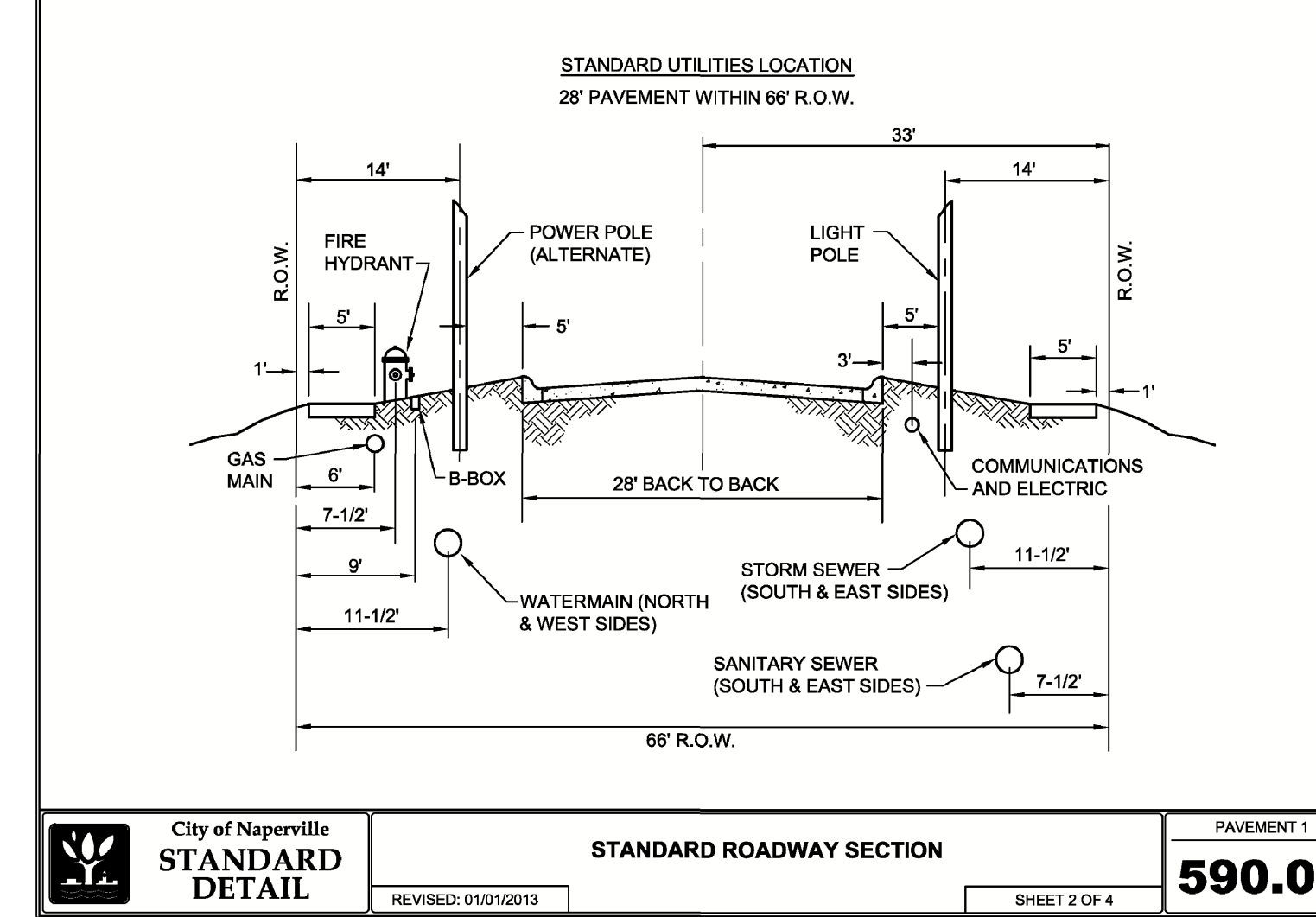
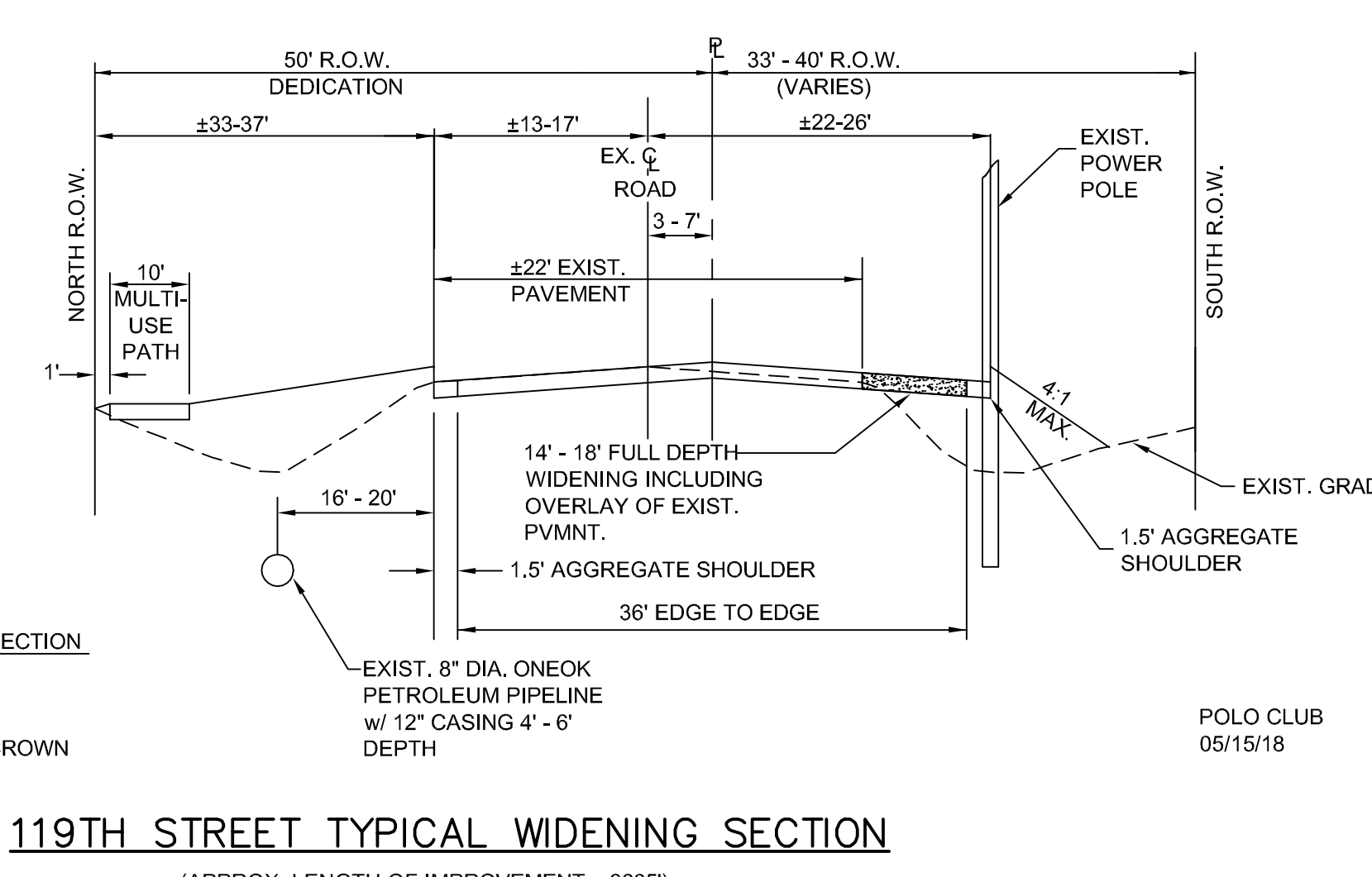
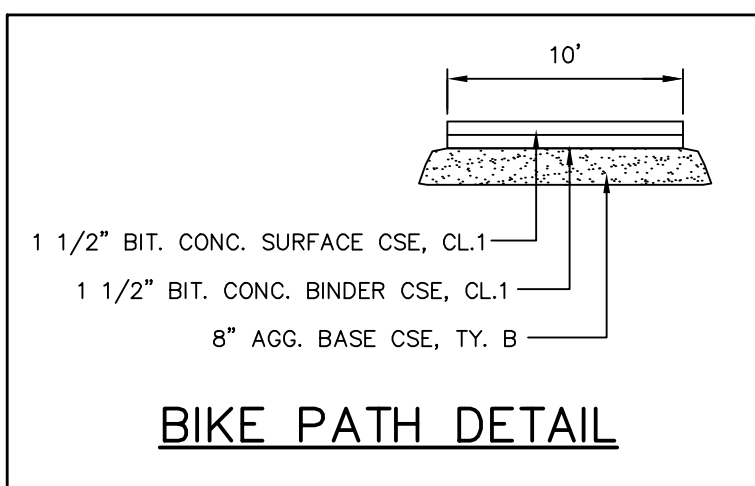
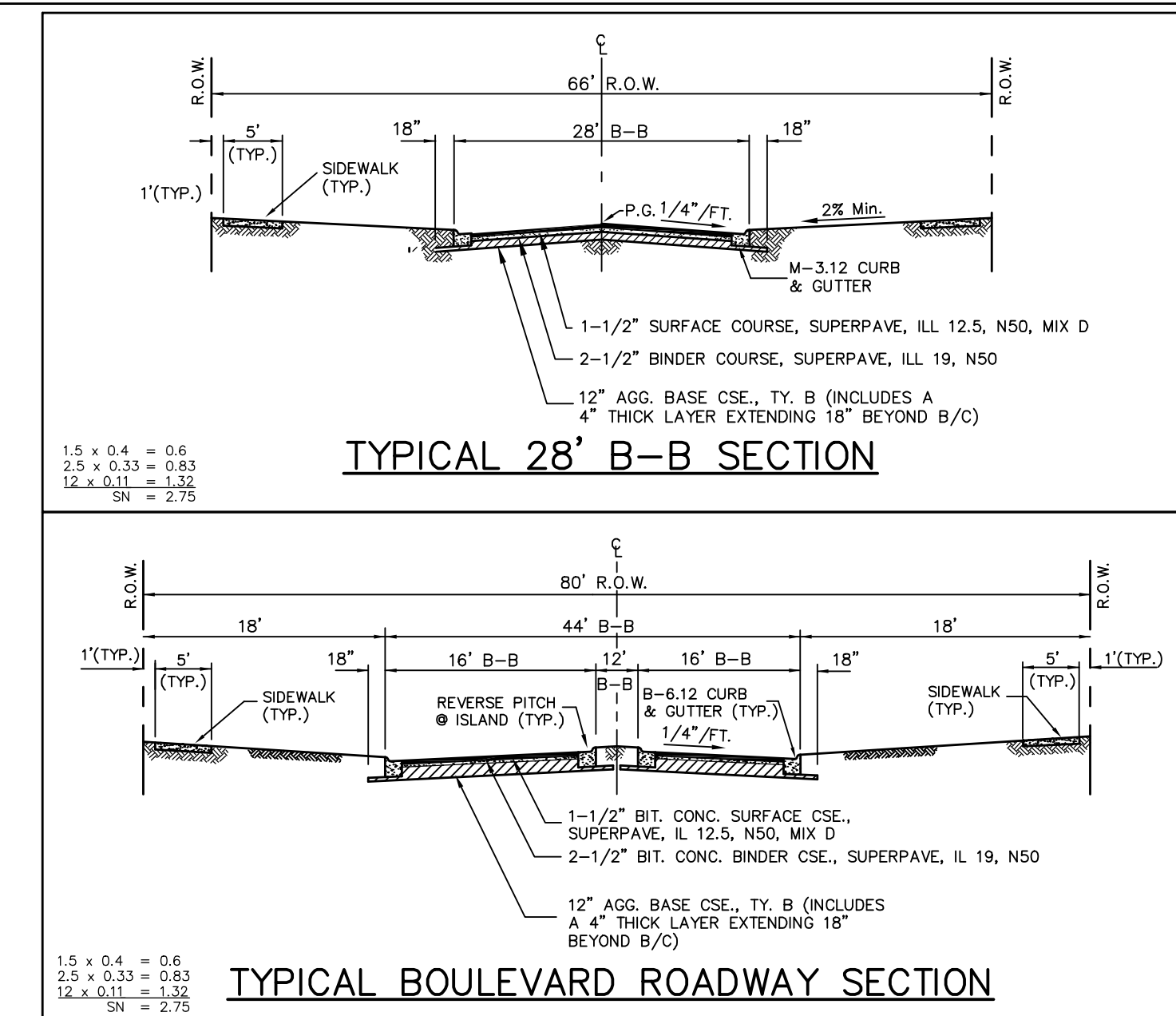
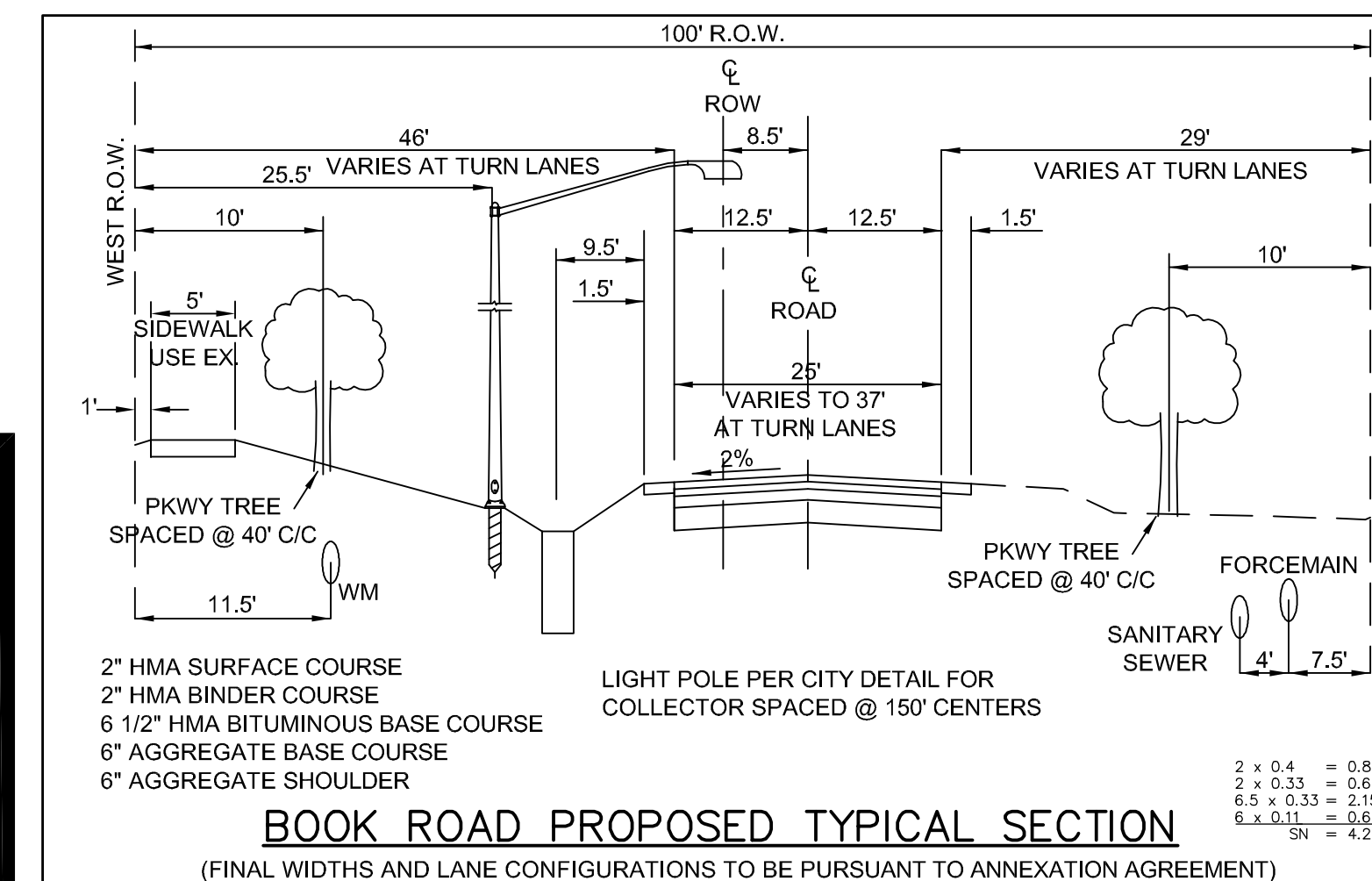
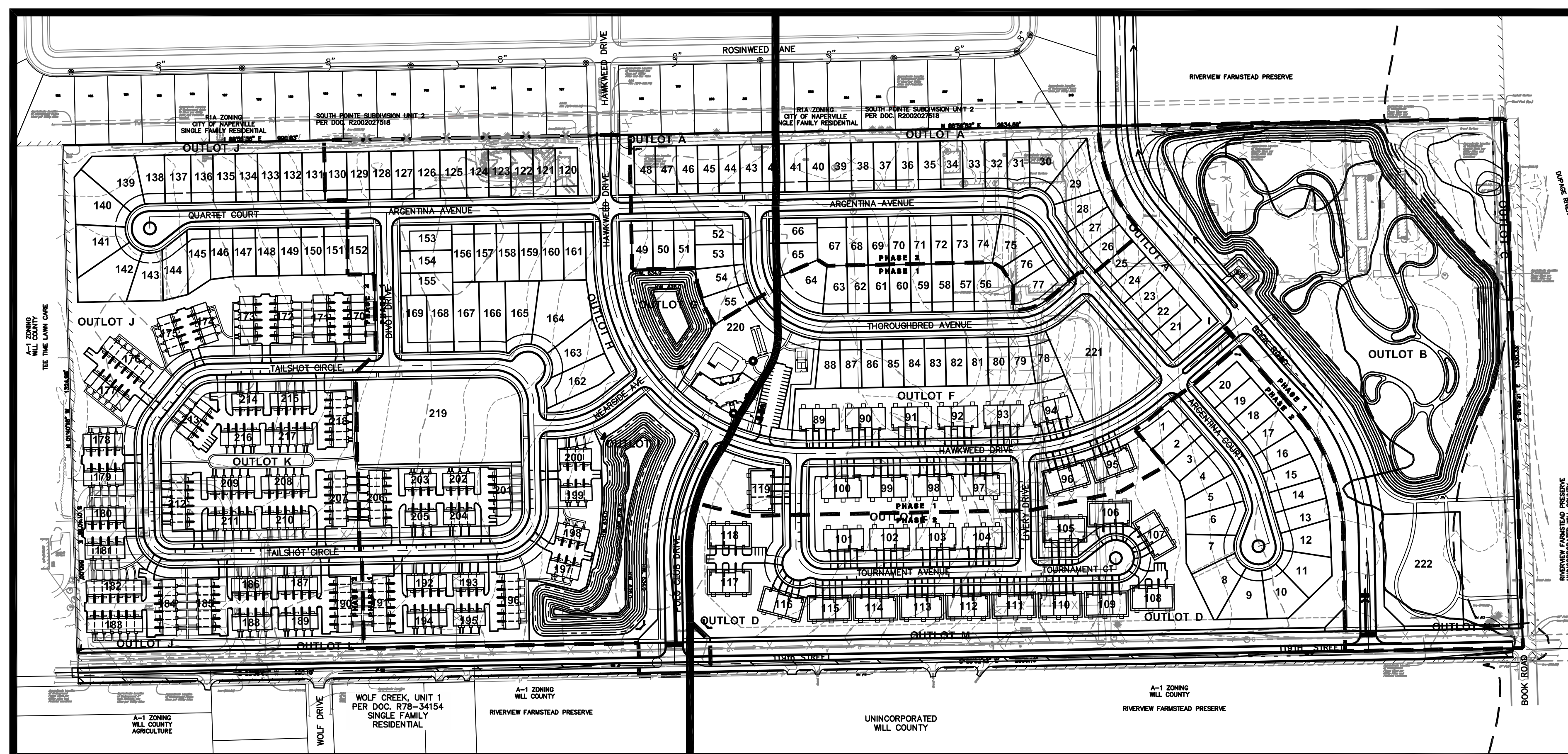

PREPARED FOR:  
**D.R. HORTON, INC.—MIDWEST,**  
 A CALIFORNIA CORPORATION  
 750 E. BUNKER COURT, SUITE 500  
 VERNON HILLS, IL 60061  
 (847) 362-9100

PREPARED BY:  
**CEMCON, Ltd.**  
 Consulting Engineers, Land Surveyors & Planners  
 2280 White Oak Circle, Suite 100  
 Aurora, Illinois 60502-9675  
 PH: 630.862.2100 FAX: 630.862.2199  
 E-Mail: cadd@cemcon.com Website: www.cemcon.com

DISC NO.: 637014 FILE NAME: PREOVR  
 DRAWN BY: LAL FLD. BK. / PG. NO.: BK./PG.  
 COMPLETION DATE: 03-26-18 JOB NO.: 637.014  
 XREF : TOPO PROJECT MANAGER : KTS  
 REV: 06-04-18/KMS PER CITY COMMENT REVIEW LETTER DATED 05-31-18  
 REV: 07-06-18/KMS PER CITY COMMENT REVIEW LETTER DATED 06-21-18  
 REV: 08-14-18/JCC PER CITY COMMENT REVIEW LETTER DATED 08-07-18  
 REV: 09-28-18/HAG PER REVISED LAND PLAN  
 REV: 10-03-18/HAG PER CITY REVIEW DATED 10-01-2018  
 REV: 10-17-18/HAG PER CITY REVIEW DATED 10-16-2018  
 REV: 12-07-18/HAG PER NEW LAND PLAN—REMOVED APARTMENT PARCEL  
 REV: 01-04-19/HAG PER NEW LAND PLAN AND CITY REVIEW  
 REV: 01-24-19/HAG PER CITY REVIEW LETTER DATED 01-18-19  
**NAPERVILLE POLO CLUB**  
**CITY PROJECT NUMBER 18 • 18-1000022**

# PRELIMINARY ENGINEERING PLAN FOR NAPERVILLE POLO CLUB

NAPERVILLE, IL

CONTRACTOR TO VERIFY LOCATION OF EXISTING WATERMAIN PRIOR TO CONNECTION. (8" PRESSURE CONNECTION)

EXISTING 8" DIA. WATER MAIN

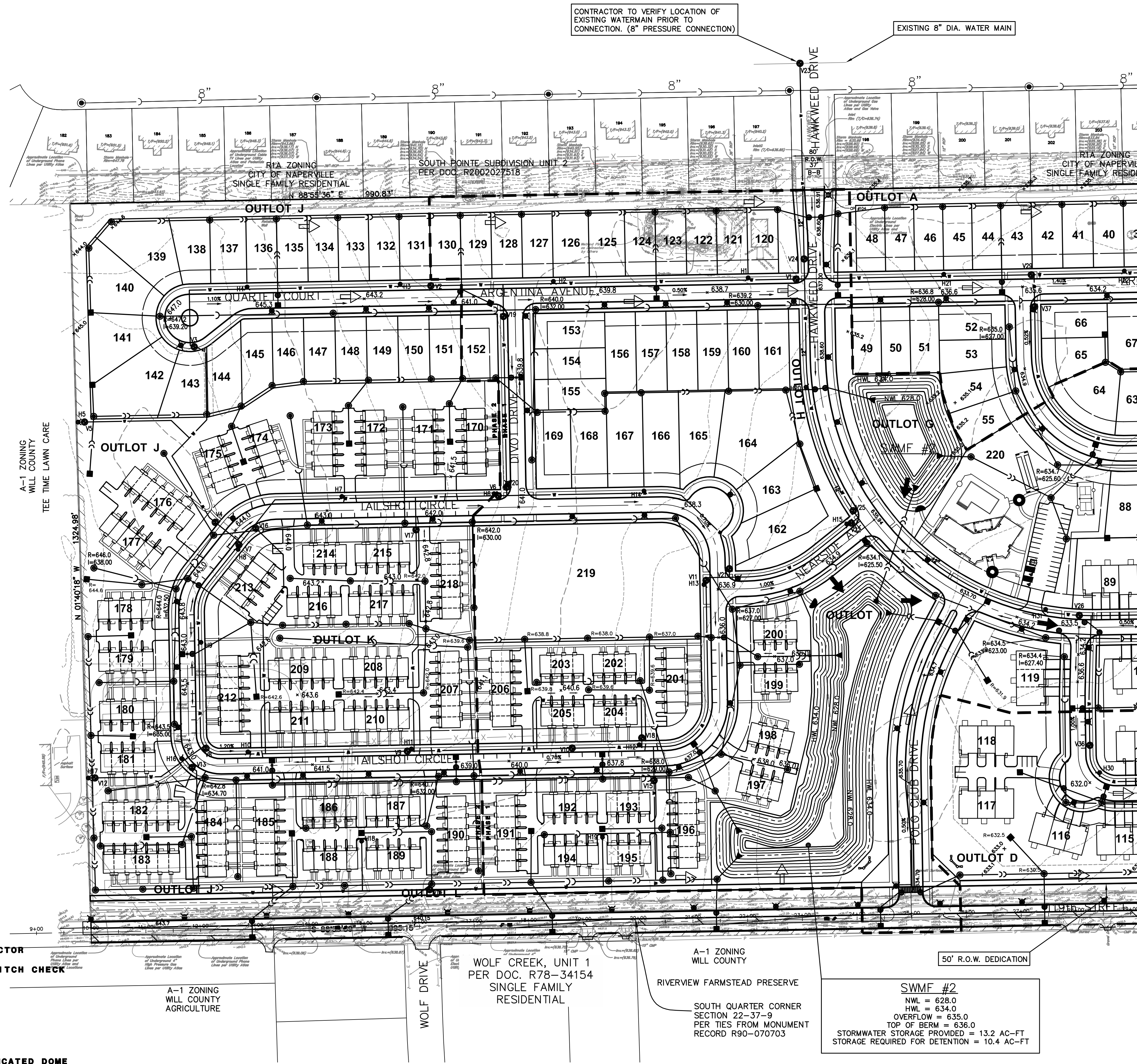
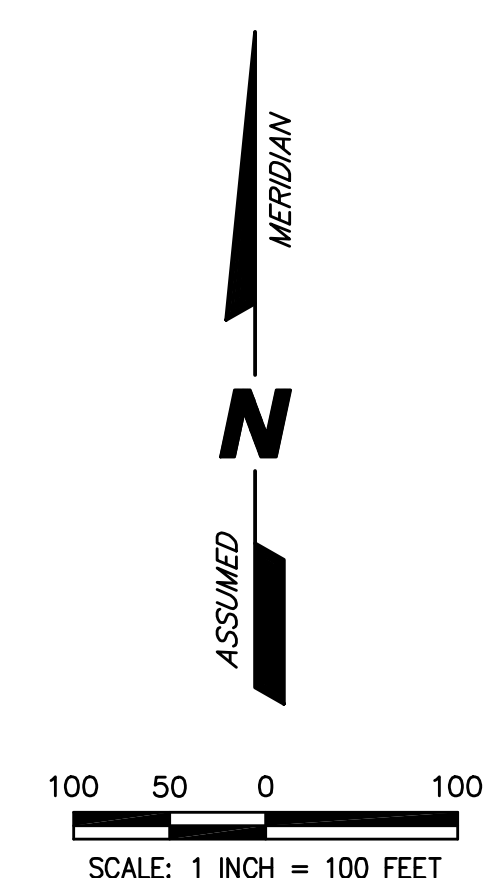

**NOTES**

DIMENSIONS SHOWN ALONG CURVED LINES ARE ARC DISTANCES.

ALL RIGHTS-OF-WAY ARE TO BE PUBLIC DEDICATIONS.

ALL STREETS, UTILITY PIPES AND MAINS SHALL BE PUBLICLY OWNED AND MAINTAINED.

STORMWATER STORAGE VOLUMES TO BE PROVIDED AND THE DESIGN OF STORMWATER MANAGEMENT FACILITIES SHALL BE IN ACCORDANCE WITH CITY OF NAPERVILLE AND WILL COUNTY REQUIREMENTS.

UNLESS OTHERWISE NOTED ALL WATERMAIN AND SANITARY SEWER TO BE 8" DIAMETER. SIZING IS BASED ON PRELIMINARY CALCULATIONS, AND MAY CHANGE AT THE TIME OF FINAL ENGINEERING.

ADDITIONAL P.U. & D.E. EASEMENTS MAY BE REQUIRED ON FINAL PLATS BASED ON UTILITY SIZE AND LOCATIONS FROM FINAL ENGINEERING.

10 FOOT WIDE PERIMETER P.U. & D.E. STRIP STYLE EASEMENTS WILL BE GRANTED ON ALL STORMWATER MANAGEMENT AREAS ON FINAL PLAT

A BLANKET STYLE STORMWATER MANAGEMENT EASEMENT WILL BE GRANTED ON ALL STORMWATER MANAGEMENT AREAS.

ALL SANITARY SERVICE CONNECTIONS TO SANITARY SEWER MAINS MUST HAVE AN OVERHEAD SEWER SYSTEM WITHIN THE BUILDING.

ANY EXISTING WELLS OR SEPTIC SYSTEMS TO BE REMOVED, ABANDONED AND/OR SEALED IN ACCORDANCE W/ WILL COUNTY HEALTH DEPT. REGULATIONS. DOCUMENTATION TO BE PROVIDED TO THE CITY.

ANY TRAILS NOT IN PUBLIC RIGHT-OF-WAY WILL BE MAINTAINED BY THE HOME OWNERS ASSOCIATION.

APPROPRIATE SIGNAGE AND STRIPING WILL BE PROVIDED WITH THE FINAL ENGINEERING PLANS.

THE MINIMUM DISTANCE FROM THE R.O.W. OF A PUBLIC STREET AND THE HWL SHALL BE TEN (10) FEET PLUS ONE AND ONE-HALF TIMES THE MAXIMUM DEPTH OF A DETENTION FACILITY. WET BOTTOM PONDS EXCEEDING 2 FEET OF NORMAL WATER DEPTH SHALL INCLUDE A SAFETY LEDGE PER DESIGN MANUAL FOR PUBLIC IMPROVEMENTS.

ALL MULTI-FAMILY BUILDINGS SHALL HAVE A SINGLE FIRE LINE SERVICE FOR EACH BUILDING THAT ENTERS AT A SPRINKLER ROOM.

### LEGEND

EXISTING	PROPOSED	DESCRIPTION
		MANHOLE
		CATCH BASIN INLET
		CLEANOUT
		SLOPE INLET BOX
		HEADWALL
		END SECTION
		STORM SEWER
		SANITARY SEWER
		FORCEMAIN
		WATERMAIN
		VALVE & BOX
		WATER VALVE IN VAULT
		FIRE HYDRANT
		CONTOURS
		ELEVATIONS
		STREET LIGHT
		WATERMAIN PROTECTION
		SILT FENCE INLET PROTECTOR
		TEMPORARY STRAW BALE DITCH CHECK
		SILT FENCE DITCH CHECK
		RIP-RAP
		MINOR OVERFLOW ROUTE
		MAJOR OVERFLOW ROUTE
		DETECTABLE WARNING TRUNCATED DOME

PREPARED FOR:  
D.R. HORTON, INC.—MIDWEST,  
A CALIFORNIA CORPORATION  
750 E. BUNKER COURT, SUITE 500  
VERNON HILLS, IL 60061  
(847) 362-9100

PREPARED BY:  
**CEMCON, Ltd.**  
Consulting Engineers, Land Surveyors & Planners  
2280 White Oak Circle, Suite 100  
Aurora, Illinois 60502-9675  
PH: 630.862.2100 FAX: 630.862.2199  
E-Mail: cadd@cemcon.com Website: www.cemcon.com

DISC NO.: 637014 FILE NAME: PREOVR  
DRAWN BY: LAL FLD. BK. / PG. NO.: BK./PG.  
COMPLETION DATE: 03-26-18 JOB NO.: 637.014  
XREF : TOPO PROJECT MANAGER : KTS  
REV: 06-04-18/KMS PER CITY COMMENT REVIEW LETTER DATED 05-31-18  
REV: 07-06-18/KMS PER CITY COMMENT REVIEW LETTER DATED 06-21-18  
REV: 08-14-18/JCC PER CITY COMMENT REVIEW LETTER DATED 08-07-18  
REV: 09-28-18/HAG PER REVISED LAND PLAN  
REV: 10-03-18/HAG PER CITY REVIEW DATED 10-01-2018  
REV: 10-17-18/HAG PER CITY REVIEW DATED 10-16-2018  
REV: 12-07-18/HAG PER NEW LAND PLAN—REMOVED APARTMENT PARCEL  
REV: 01-04-19/HAG PER NEW LAND PLAN AND CITY REVIEW  
REV: 01-24-19/HAG PER CITY REVIEW LETTER DATED 01-18-19  
**NAPERVILLE POLO CLUB**  
**CITY PROJECT NUMBER 18 • 18-1000022**

**SWMF #2**  
HWL = 628.0  
HWL = 634.0  
OVERFLOW = 635.0  
TOP OF BERM = 636.0  
STORMWATER STORAGE PROVIDED = 13.2 AC-FT  
STORAGE REQUIRED FOR DETENTION = 10.4 AC-FT

PLOT FILE CREATED: 1/24/2018 BY: HEATHER GARDNER DRAWING PATH: P:\EST01\KUNO\DWG\DRAWINGS\PRELIMINARY\PREOVR.DWG

# PRELIMINARY ENGINEERING PLAN FOR NAPERVILLE POLO CLUB

NAPERVILLE, IL



100 50 0 100  
SCALE: 1 INCH = 100 FEET

PRESSURE CONECT TO EXISTING 8" DIA. WATER MAIN AT THE NORTH EAST CORNER OF LOT 270. CONNECTION IS APPROXIMATELY 1,200' NORTH OF THE NORTHERN PROPERTY LINE OF POLO CLUB.

FLOODWAY LIMIT

PROPOSED LIFT STATION AND FORCE MAIN. FORCE MAIN TO RUN NORTH AND CONNECT TO EXISTING 24" DIA. SEWER AT 111TH ST. LENGTH IS APPROX. 4150' NORTH OF POLO CLUB NORTH PROPERTY LINE.

NOTE:  
ALL SANITARY SEWER IS 8" DIA. UNLESS OTHERWISE NOTED.  
ALL WATER MAIN IS 8" DIA. UNLESS OTHERWISE NOTED AS 12" DIA.

### NOTES

- DIMENSIONS SHOWN ALONG CURVED LINES ARE ARC DISTANCES.
- ALL RIGHTS-OF-WAY ARE TO BE PUBLIC DEDICATIONS.
- ALL STREETS, UTILITY PIPES AND MAINS SHALL BE PUBLICLY OWNED AND MAINTAINED.
- STORMWATER STORAGE VOLUMES TO BE PROVIDED AND THE DESIGN OF STORMWATER MANAGEMENT FACILITIES SHALL BE IN ACCORDANCE WITH CITY OF NAPERVILLE AND WILL COUNTY REQUIREMENTS.
- UNLESS OTHERWISE NOTED ALL WATERMAIN AND SANITARY SEWER TO BE 8" DIAMETER.
- ADDITIONAL P.U. & D.E. EASEMENTS MAY BE REQUIRED ON FINAL PLATS BASED ON UTILITY SIZE AND LOCATIONS FROM FINAL ENGINEERING.
- 10 FOOT WIDE PERIMETER P.U. & D.E. STRIP STYLE EASEMENTS WILL BE GRANTED ON ALL STORMWATER MANAGEMENT AREAS ON FINAL PLAT
- A BLANKET STYLE STORMWATER MANAGEMENT EASEMENT WILL BE GRANTED ON ALL STORMWATER MANAGEMENT AREAS.
- ALL SANITARY SERVICE CONNECTIONS TO SANITARY SEWER MAINS MUST HAVE AN OVERHEAD SEWER SYSTEM WITHIN THE BUILDING.
- ANY EXISTING WELLS OR SEPTIC SYSTEMS TO BE REMOVED, ABANDONED AND/OR SEALED IN ACCORDANCE w/WILL COUNTY HEALTH DEPT. REGULATIONS. DOCUMENTATION TO BE PROVIDED TO THE CITY
- ANY TRAILS NOT IN PUBLIC RIGHT-OF-WAY WILL BE MAINTAINED BY THE HOME OWNERS ASSOCIATION.
- APPROPRIATE SIGNAGE AND STRIPING WILL BE PROVIDED WITH THE FINAL ENGINEERING PLANS.

### LEGEND

EXISTING	PROPOSED	DESCRIPTION
		MANHOLE
		CATCH BASIN
		INLET
		CLEANOUT
		SLOPE INLET BOX
		HEADWALL
		END SECTION
		STORM SEWER
		SANITARY SEWER
		FORCEMAIN
		WATERMAIN
		VALVE & BOX
		WATER VALVE IN VAULT
		FIRE HYDRANT
		CONTOURS
		ELEVATIONS
		STREET LIGHT
		WATERMAIN PROTECTION
		SILT FENCE INLET PROTECTOR
		TEMPORARY STRAW BALE DITCH CHECK
		SILT FENCE DITCH CHECK
		RIP-RAP
		MINOR OVERFLOW ROUTE
		MAJOR OVERFLOW ROUTE
		DETECTABLE WARNING TRUNCATED DOME

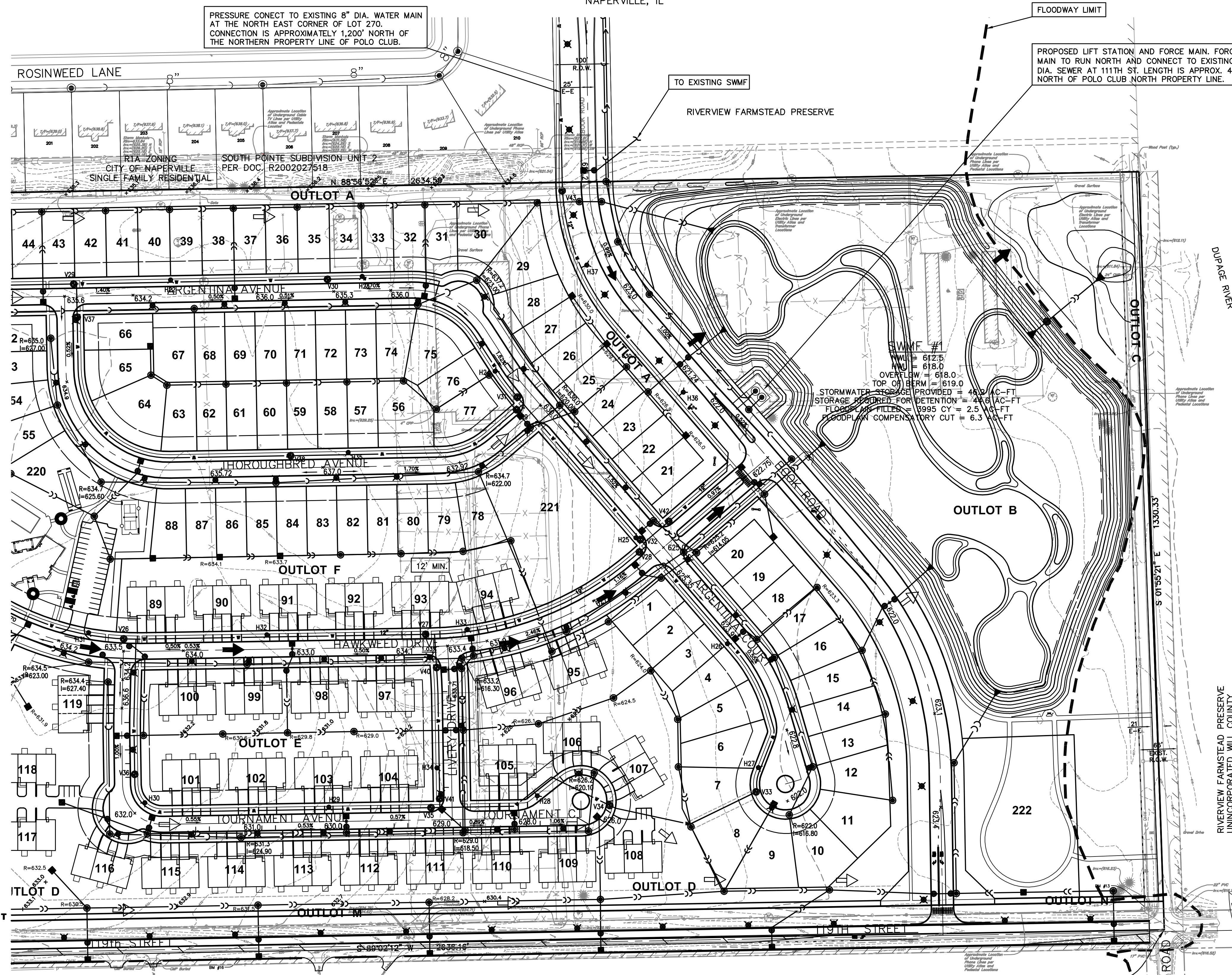

SE CORNER OF SECTION 22-37-9 FOUND IRON ROD PER MONUMENT RECORD R2010-051625

PREPARED FOR:  
D.R. HORTON, INC.—MIDWEST,  
A CALIFORNIA CORPORATION  
750 E. BUNKER COURT, SUITE 500  
VERNON HILLS, IL 60061  
(847) 362-9100

PREPARED BY:  
**CEMCON, Ltd.**  
Consulting Engineers, Land Surveyors & Planners  
2280-White Oak Circle, Suite 100  
Aurora, Illinois 60502-9675  
PH: 630.862.2100 FAX: 630.862.2199  
E-Mail: cadd@cemcon.com Website: www.cemcon.com

DISC NO.: 637014 FILE NAME: PREOVR  
DRAWN BY: LAL FLD. BK. / PG. NO.: BK./PG.  
COMPLETION DATE: 03-26-18 JOB NO.: 637.014  
XREF : TOPO PROJECT MANAGER : KTS  
REV: 06-04-18/KMS PER CITY COMMENT REVIEW LETTER DATED 05-31-18  
REV: 07-06-18/KMS PER CITY COMMENT REVIEW LETTER DATED 06-21-18  
REV: 08-14-18/JGC PER CITY COMMENT REVIEW LETTER DATED 08-07-18  
REV: 09-28-18/HAG PER REVISED LAND PLAN  
REV: 10-03-18/HAG PER CITY REVIEW DATED 10-01-2018  
REV: 10-17-18/HAG PER CITY REVIEW DATED 10-16-2018  
REV: 12-07-18/HAG PER NEW LAND PLAN-REMOVED APARTMENT PARCEL  
REV: 01-04-19/HAG PER NEW LAND PLAN AND CITY REVIEW  
REV: 01-24-19/HAG PER CITY REVIEW LETTER DATED 01-18-19  
**NAPERVILLE POLO CLUB**  
**CITY PROJECT NUMBER 18 • 18-1000022**

# PRELIMINARY ENGINEERING PLAN FOR NAPERVILLE POLO CLUB

NAPERVILLE, IL

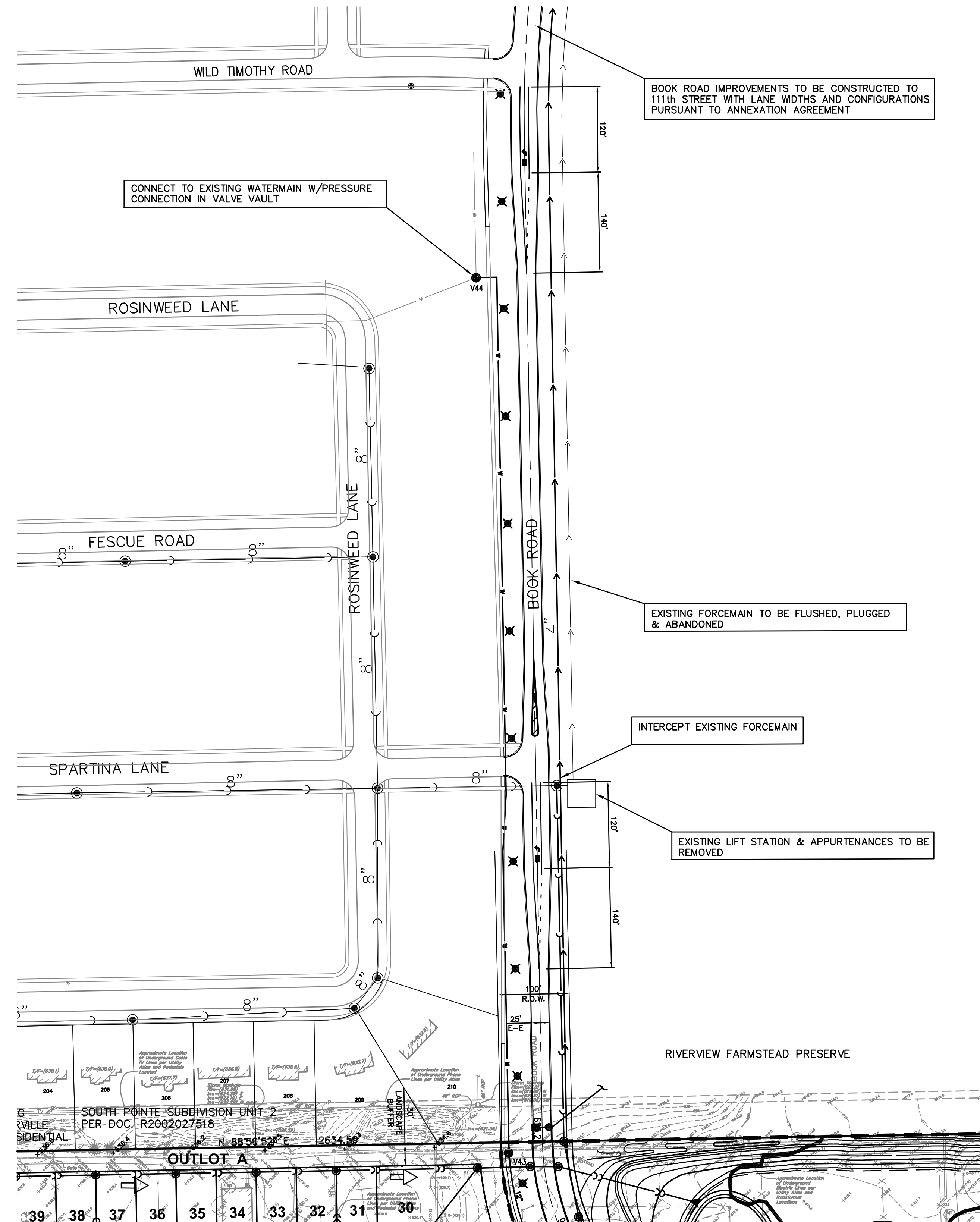
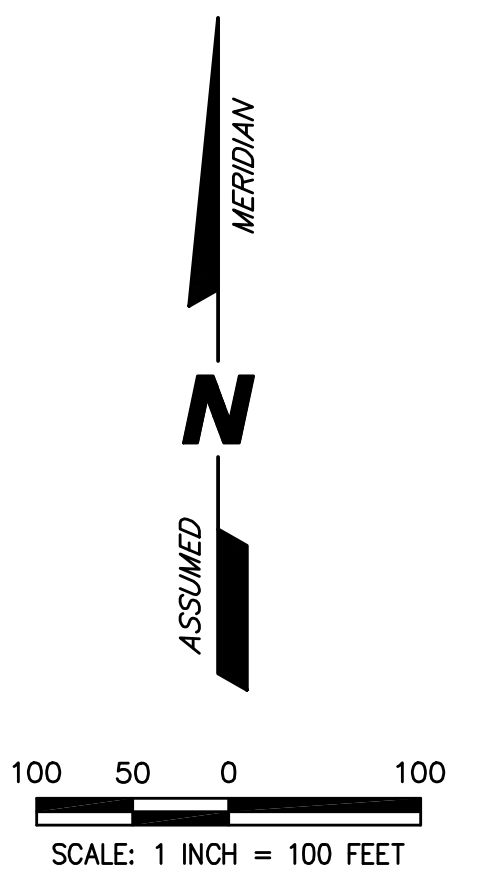

**NOTE:**  
ALL SANITARY SEWER IS 8" DIA. UNLESS OTHERWISE NOTED.  
ALL WATER MAIN IS 8" DIA. UNLESS OTHERWISE NOTED AS 12" DIA.

- NOTES**
- DIMENSIONS SHOWN ALONG CURVED LINES ARE ARC DISTANCES.
  - ALL RIGHTS-OF-WAY ARE TO BE PUBLIC DEDICATIONS.
  - ALL STREETS, UTILITY PIPES AND MAINS SHALL BE PUBLICLY OWNED AND MAINTAINED.
  - STORMWATER STORAGE VOLUMES TO BE PROVIDED AND THE DESIGN OF STORMWATER MANAGEMENT FACILITIES SHALL BE IN ACCORDANCE WITH CITY OF NAPERVILLE AND WILL COUNTY REQUIREMENTS.
  - UNLESS OTHERWISE NOTED ALL WATERMAIN AND SANITARY SEWER TO BE 8" DIAMETER.
  - ADDITIONAL P.U. & D.E. EASEMENTS MAY BE REQUIRED ON FINAL PLATS BASED ON UTILITY SIZE AND LOCATIONS FROM FINAL ENGINEERING.
  - 10 FOOT WIDE PERIMETER P.U. & D.E. STRIP STYLE EASEMENTS WILL BE GRANTED ON ALL STORMWATER MANAGEMENT AREAS ON FINAL PLAT
  - A BLANKET STYLE STORMWATER MANAGEMENT EASEMENT WILL BE GRANTED ON ALL STORMWATER MANAGEMENT AREAS.
  - ALL SANITARY SERVICE CONNECTIONS TO SANITARY SEWER MAINS MUST HAVE AN OVERHEAD SEWER SYSTEM WITHIN THE BUILDING.
  - ANY EXISTING WELLS OR SEPTIC SYSTEMS TO BE REMOVED, ABANDONED AND/OR SEALED IN ACCORDANCE w/WILL COUNTY HEALTH DEPT. REGULATIONS. DOCUMENTATION TO BE PROVIDED TO THE CITY
  - ANY TRAILS NOT IN PUBLIC RIGHT-OF-WAY WILL BE MAINTAINED BY THE HOME OWNERS ASSOCIATION.
  - APPROPRIATE SIGNAGE AND STRIPING WILL BE PROVIDED WITH THE FINAL ENGINEERING PLANS.

**LEGEND**

EXISTING	PROPOSED	DESCRIPTION
		MANHOLE
		CATCH BASIN
		INLET
		CLEANOUT
		SLOPE INLET BOX
		HEADWALL
		END SECTION
		STORM SEWER
		SANITARY SEWER
		FORCEMAIN
		WATERMAIN
		VALVE & BOX
		WATER VALVE IN VAULT
		FIRE HYDRANT
		CONTOURS
		ELEVATIONS
		STREET LIGHT
		WATERMAIN PROTECTION
		SILT FENCE INLET PROTECTOR
		TEMPORARY STRAW BALE DITCH CHECK
		SILT FENCE DITCH CHECK
		RIP-RAP
		MINOR OVERFLOW ROUTE
		MAJOR OVERFLOW ROUTE
		DETECTABLE WARNING TRUNCATED DOME

PREPARED FOR:  
D.R. HORTON, INC.-MIDWEST,  
A CALIFORNIA CORPORATION  
750 E. BUNKER COURT, SUITE 500  
VERNON HILLS, IL 60061  
(847) 362-9100

PREPARED BY:  
**CEMCON, Ltd.**  
Consulting Engineers, Land Surveyors & Planners  
2280 White Oak Circle, Suite 100  
Aurora, Illinois 60502-9675  
PH: 630.862.2100 FAX: 630.862.2199  
E-Mail: cadd@cemcon.com Website: www.cemcon.com

DISC NO.: 637014 FILE NAME: PREOVR  
DRAWN BY: LAL FLD. BK. / PG. NO.: BK./PG.  
COMPLETION DATE: 03-26-18 JOB NO.: 637.014  
XREF : TOPO PROJECT MANAGER : KTS  
REV: 06-04-18/KMS PER CITY COMMENT REVIEW LETTER DATED 05-31-18  
REV: 07-06-18/KMS PER CITY COMMENT REVIEW LETTER DATED 06-21-18  
REV: 08-14-18/JGC PER CITY COMMENT REVIEW LETTER DATED 08-07-18  
REV: 09-28-18/HAG PER REVISED LAND PLAN  
REV: 10-03-18/HAG PER CITY REVIEW DATED 10-01-2018  
REV: 10-17-18/HAG PER CITY REVIEW DATED 10-16-2018  
REV: 12-07-18/HAG PER NEW LAND PLAN-REMOVED APARTMENT PARCEL  
REV: 01-04-19/HAG PER NEW LAND PLAN AND CITY REVIEW  
REV: 01-24-19/HAG PER CITY REVIEW LETTER DATED 01-18-19  
**NAPERVILLE POLO CLUB**  
**CITY PROJECT NUMBER 18 • 18-1000022**

PLOT FILE CREATED: 1/24/2018 BY: HEATHER GARDNER