



SITE PLAN MILL AND BAUER TOWNHOMES

P.I.N.: 07-12-226-002
07-12-209-022
ADDRESS: 27W280 BAUER ROAD
NAPERVILLE, IL 60563



NO.	DATE	DESCRIPTION
1	03/21/2023	REVISION PER CITY REVIEW, DATED 02/13/2023
2	04/03/2023	REVISION PER CLIENT REVIEW
3	04/03/2023	REVISION PER CITY REVIEW, DATED 03/16/2023
4	10/26/2023	REVISION PER CITY REVIEW, DATED 10/26/2023

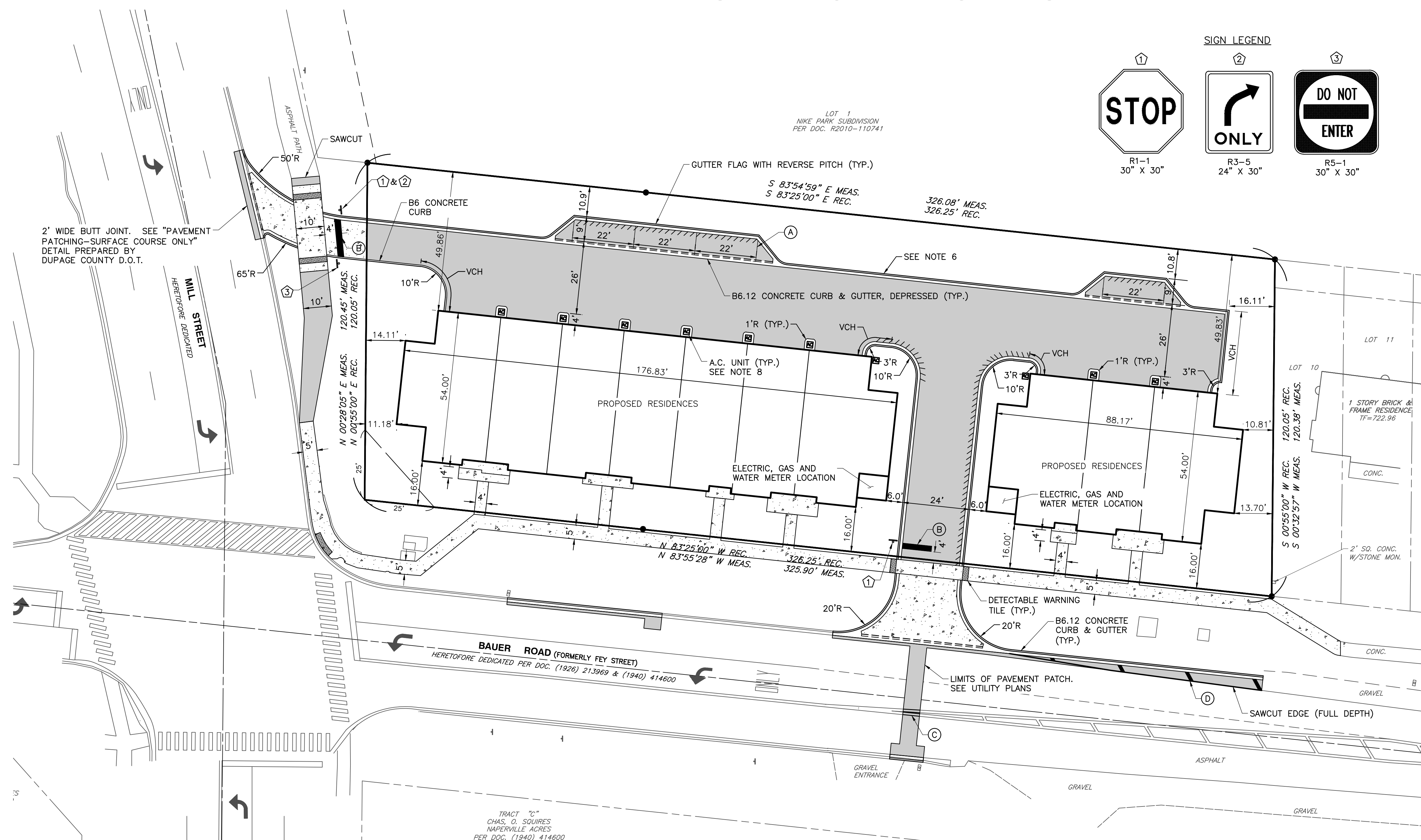
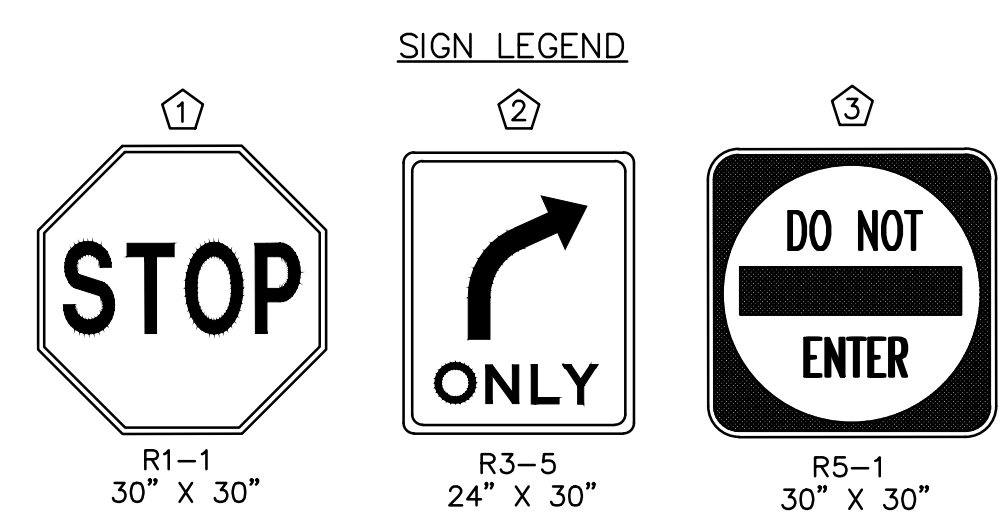

- DIMENSION NOTES:**
- UNLESS OTHERWISE NOTED, ALL DIMENSIONS ARE TO THE BACK OF CURB, FACE OF BUILDING, EDGE OF SIDEWALK OR PROPERTY LINE.
 - FOR PROPOSED BUILDING DIMENSIONS SEE ARCHITECTURAL PLANS.
 - PUBLIC HANDICAP RAMP DETAILS SHALL BE CONSTRUCTED IN ACCORDANCE WITH IDOT STANDARD 424001.
 - ALL PAVEMENT MARKINGS SHALL BE THERMOPLASTIC AND SHALL BE AS FOLLOWS:
 - (A) PARKING SPACES - 4" SOLID YELLOW
 - (B) STOP LINE - 24" SOLID WHITE
 - (C) CENTERLINE - (2) 4" SOLID YELLOW (11" C-C)
 - (D) EDGELINE - 4" SOLID, WHITE WITH 12" SOLID WHITE (20" C-C) AT 45°
 - 'VCH' INDICATES VARIABLE CURB HEIGHT. THE CONTRACTOR SHALL REVIEW THE PROPOSED GRADING PLAN AND TAKE NOTE WHERE PROPOSED CURB VARIES IN HEIGHT.
 - TRASH/RECYCLE CONTAINERS SHALL BE PLACED ADJACENT TO THE GARAGE DOOR IN THE 4' AREA BETWEEN THE GARAGE DOOR AND 26' DRIVE AISLE. THE TRASH/RECYCLE CONTAINERS SHALL NOT BE PLACED IN GRASS AREA ON THE NORTH SIDE OF THE DRIVE AISLE.
 - UPON COMPLETION OF THE PERMIT PROJECT, THE CONTRACTOR IS REQUIRED TO COMPLETE DUPAGE COUNTY ADA/PROWAG REPORTING FORMS. INSTRUCTIONS CAN BE FOUND AT THE DUPAGE COUNTY DOT WEBSITE WWW.DUPAGECO.GOV. PLEASE FILL OUT AND SUBMIT THE COMPLETED FORMS TO HWYPERMITS@DUPAGECO.ORG.
 - A.C. UNIT TO BE BRACKETED TO THE BUILDING WITH CEDAR SCREEN ON ALL SIDES TO THE FULL HEIGHT OF EACH UNIT.

SITE DATA

GROSS BOUNDARY AREA = 39,069 SQUARE FEET (0.897 ACRES)

NUMBER OF LOTS = 1

CURRENT ZONING = R3 (SINGLE-FAMILY RESIDENCE DISTRICT, DUPAGE COUNTY)

PROPOSED ZONING = TU (TRANSITION USE DISTRICT)

PROPOSED SETBACKS:	REQUIRED (TU)	PROPOSED
FRONT YARD (SOUTH)	= 15 FEET	16 FEET
INTERIOR SIDE YARD (EAST)	= 6 FEET	10.81 FEET
REAR YARD (NORTH)	= 25 FEET	49.83 FEET
CORNER SIDE YARD (WEST)	= 10 FEET	11.18 FEET

BUILDING AREA = 13,137 SQUARE FEET

NUMBER OF RESIDENTIAL UNITS = 10

PARKING PROVIDED:

10 UNITS x 2 SPACES/UNIT (IN GARAGE)	= 20 SPACES
VISITOR	= 4 SPACES
TOTAL	= 24 SPACES

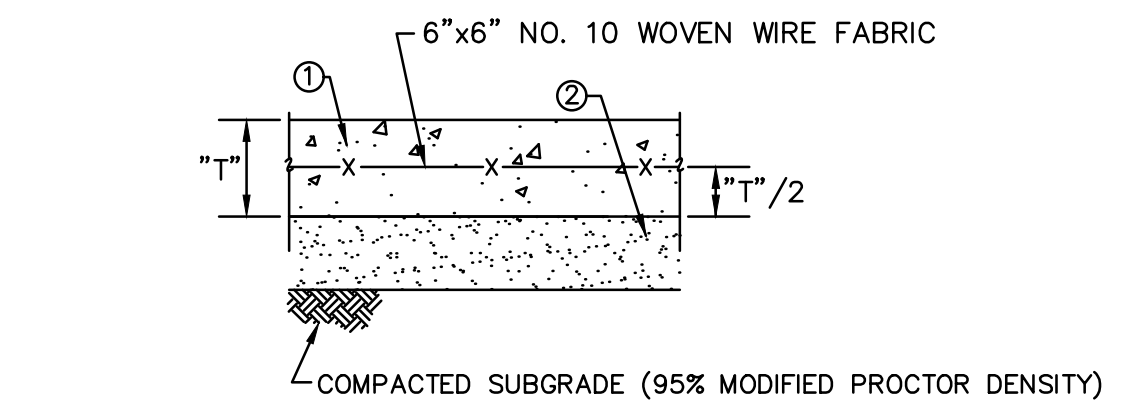
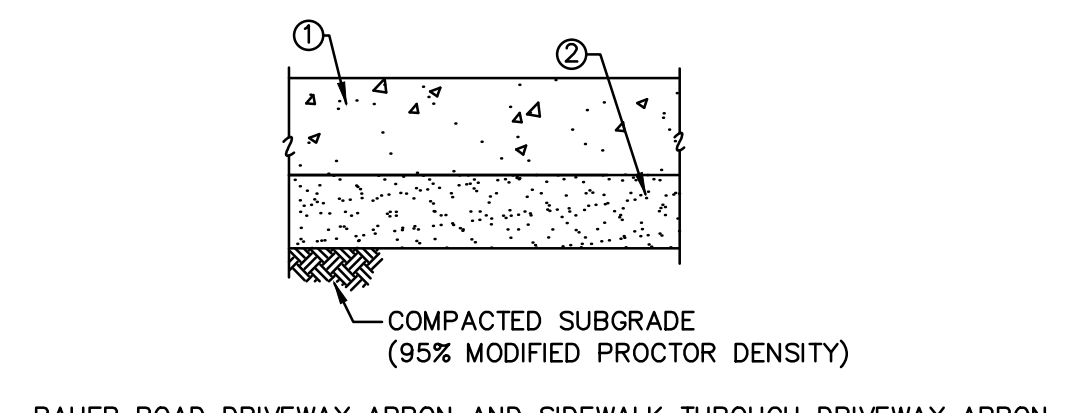
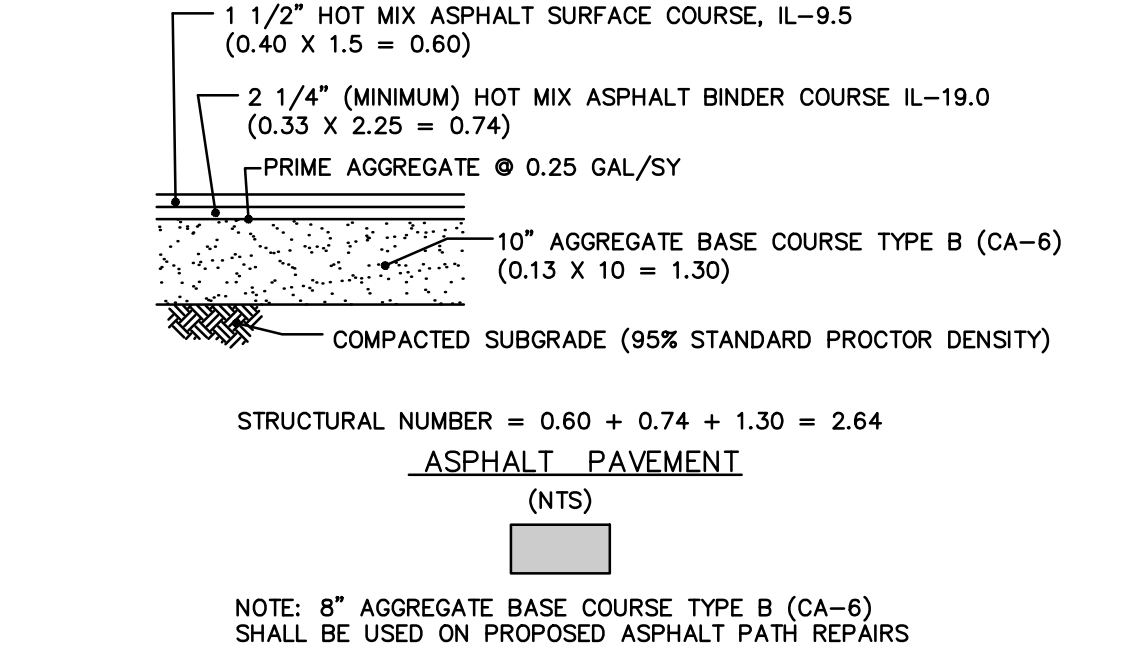

- REFERENCE**
- EXISTING CONDITIONS ARE BASED UPON FIELD OBSERVATIONS MADE ON OCTOBER 31, 2022 BY CIVIL & ENVIRONMENTAL CONSULTANTS, INC.
 - FIELD DATUM: ILLINOIS STATE PLANE NSRS 2011, EAST ZONE- US SURVEY FOOT CITY OF NAPERVILLE DATUM NAVD 88.
 - UNDERGROUND UTILITY INFORMATION SHOWN HEREON IS BASED UPON FIELD OBSERVATIONS, ATLAS MAPS PROVIDED BY THE CITY OF NAPERVILLE AND THOSE PUBLIC UTILITY COMPANIES OPERATING UNDER FRANCHISE OR CONTRACT WITH THE CITY OF NAPERVILLE.

- CONCRETE PAVEMENT (MILL STREET APRON AREA)**
- 8" PORTLAND CEMENT CONCRETE, CLASS PV
 - 8" COMPACTED CA-6 (GRADE 8) AGGREGATE BASE COURSE

- CONCRETE PAVEMENT (MILL STREET APRON AREA)**
- 8" PORTLAND CEMENT CONCRETE, CLASS PV
 - 8" COMPACTED CA-6 (GRADE 8) AGGREGATE BASE COURSE

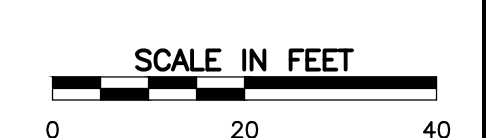
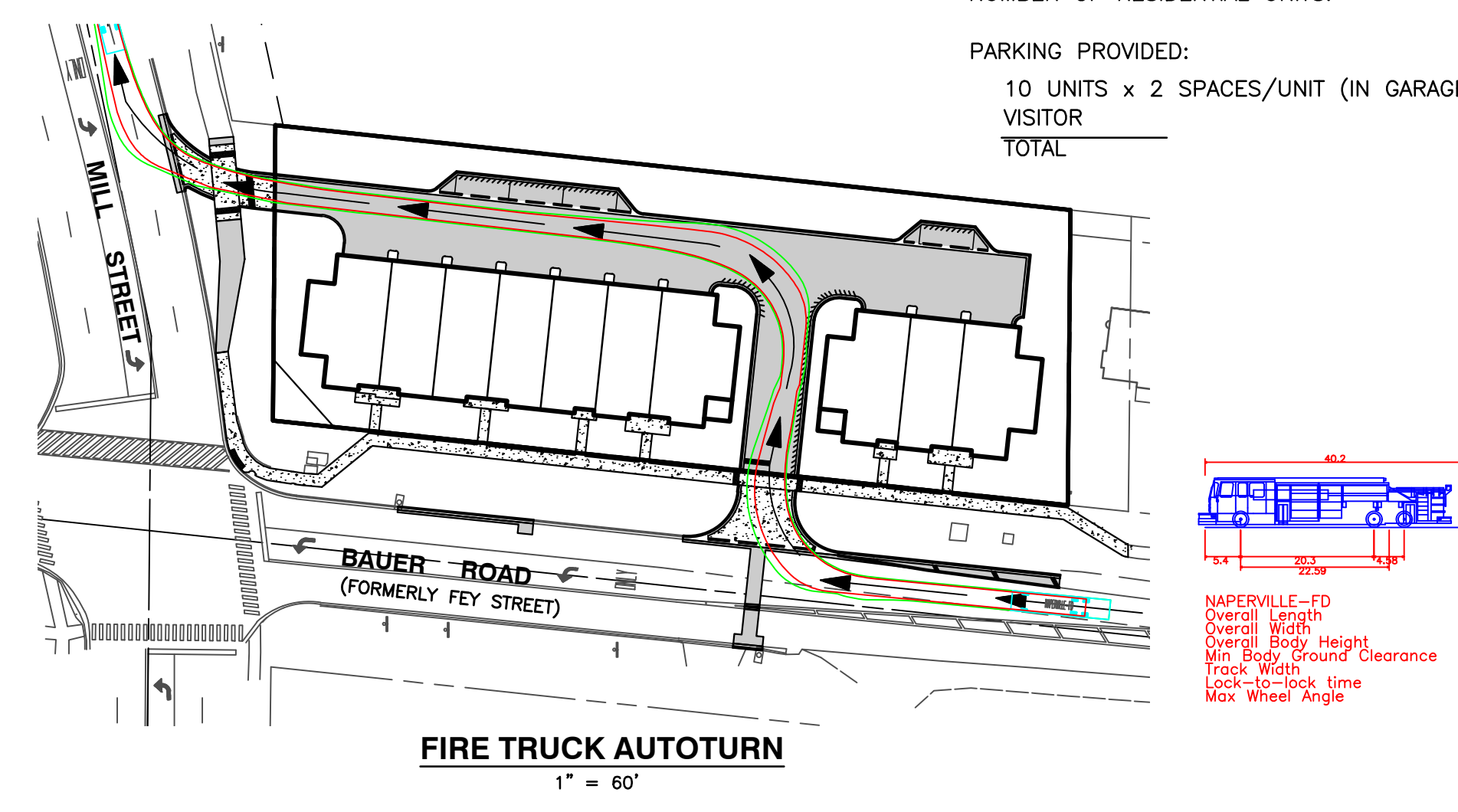

Civil & Environmental Consultants, Inc.
1230 East Diehl Road, Suite 200 - Naperville, IL 60563
630-963-6026 - 877-963-6026
www.cecinco.com

MILL AND BAUER, LLC
MILL AND BAUER TOWNHOMES
27W280 BAUER ROAD
NAPERVILLE, ILLINOIS 60563

SITE PLAN

DATE: JANUARY 16, 2023 | DRAWN BY: MAJ | JGC
DWG SCALE: 1" = 20' | CHECKED BY: JGC
PROJECT NO: 326-656-0002
APPROVED BY: JGC

DRAWING NO: **CV01**
SHEET 1 OF 1