

FRONT ELEVATION (south)
 SCALE: 1/4" = 1'-0"

DATUM POINT LEFT (WEST)	683.8
DATUM POINT RIGHT (EAST)	683.0
AVERAGE DATUM POINT	683.4

DATE JAN. 19, 2023
 JOBNO

REVNO	REVISIONS	REVDATE
1	SECUR. SUBMITAL	1/19/2023
2		
3		
4		

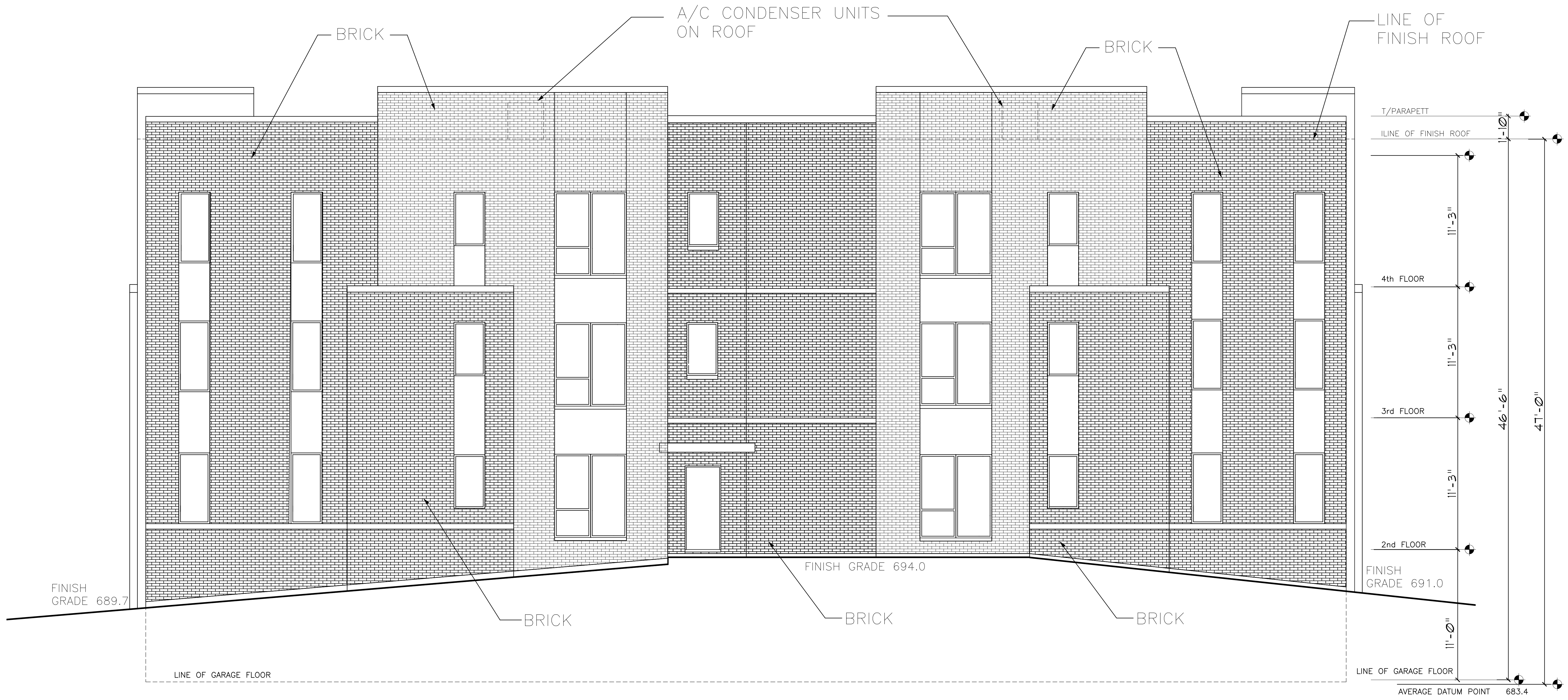

REAR ELEVATION (north)
 SCALE: 1/4" = 1'-0"

DATE JAN 19, 2023
 JOBNO

REVNO	REVISIONS	REVDATE
1	SECOND SUBMITTAL	1/28 2023
2		
3		
4		



LEFT SIDE ELEVATION (west)
 SCALE: 1/4" = 1'-0"

REVNO	REVISIONS	DATE
1	SECOND SUBMITTAL	1/19/2023
2		
3		
4		



RIGHT SIDE ELEVATION (east)

SCALE: 1/4" = 1'-0"

REVNO	REVISIONS	REVDATE
1	SECOND SUBMITTAL	1/19/2023
2		
3		
4		

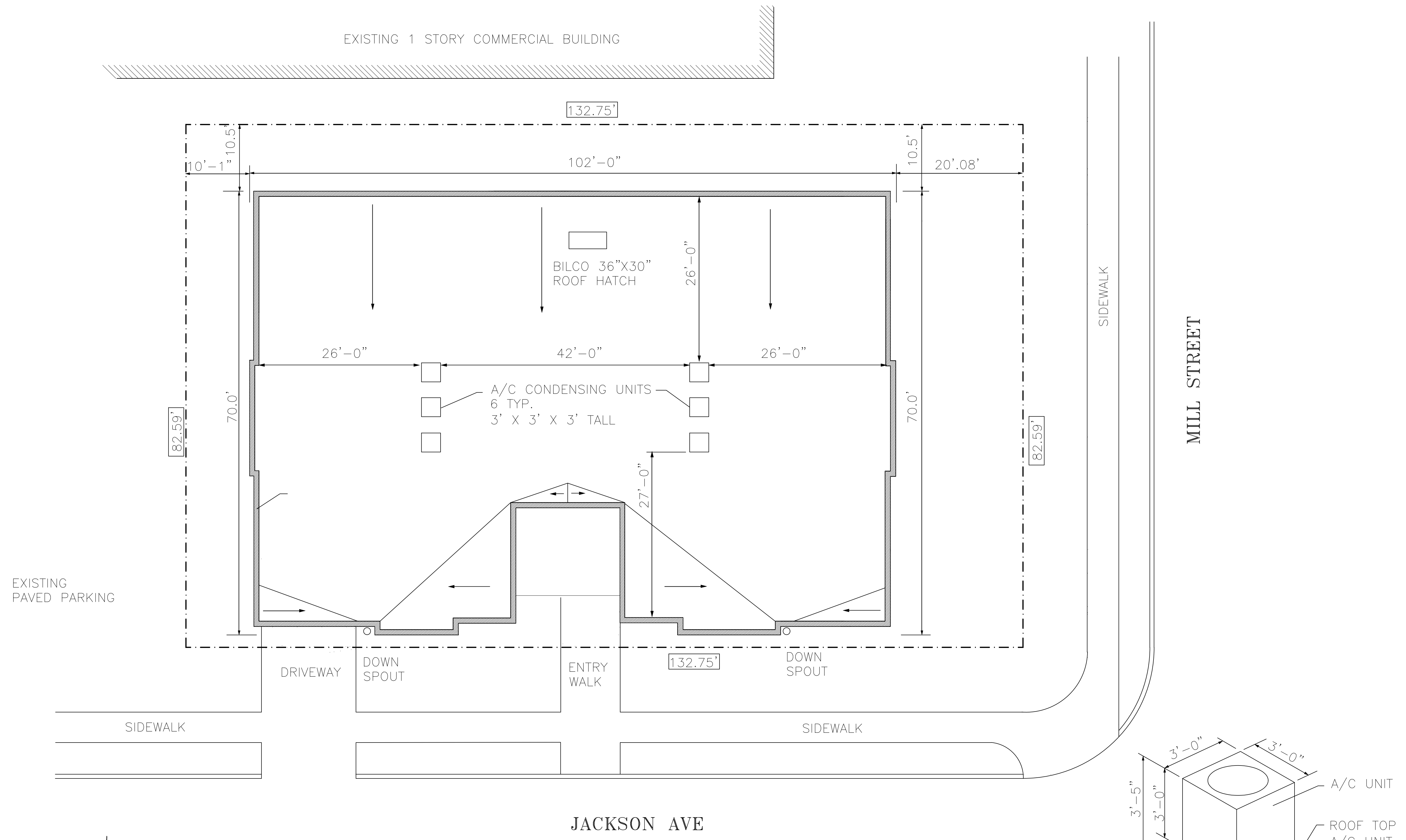

PROPOSED ROOF PLAN

SCALE: 1/8" = 1'-0"

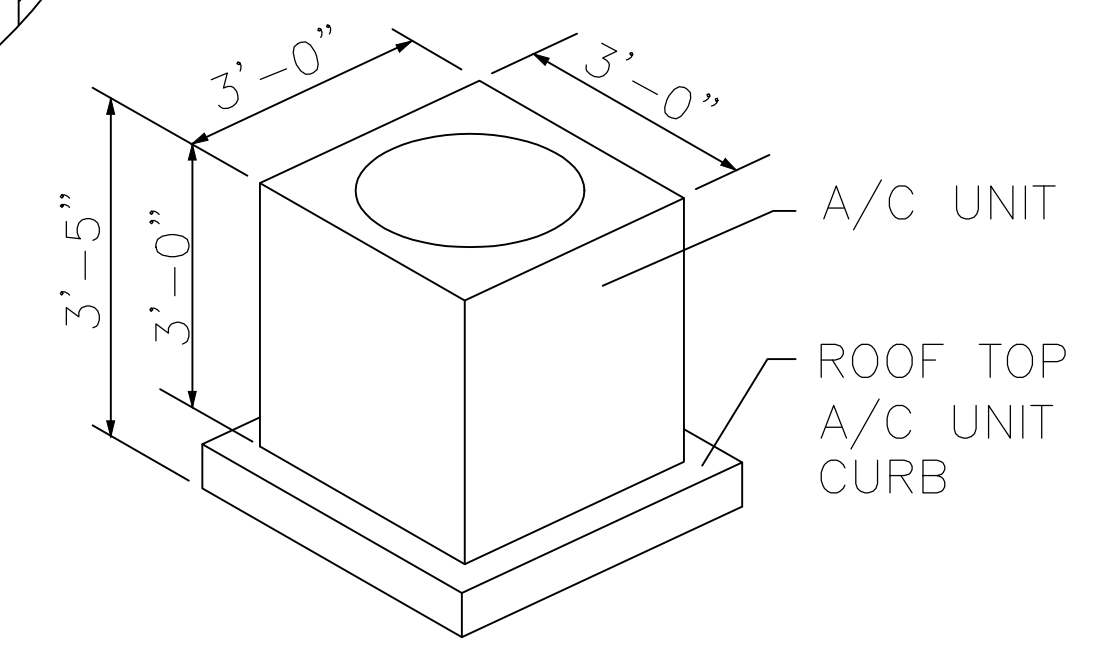

ROOF TOP A/C CONDENSER

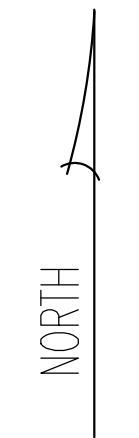

EXISTING 1 STORY COMMERCIAL BUILDING

EXISTING PAVED PARKING

MILL STREET

JACKSON AVE

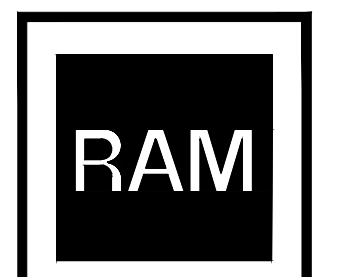

R A Miffin architect
 river forest, il 60305
 312-406-9892

RIVERWALK PLACE
 415 JACKSON AVENUE
 NAPERVILLE, IL

DATE: JAN. 19, 2023
 JOBNO:

REVISION	REVISIONS	REDATE
1	SECOND SUBMITTAL	1/26/2023
2		
3		
4		