



South Elevation

0' 5' 10' 25'



East Elevation

0' 5' 10' 25'

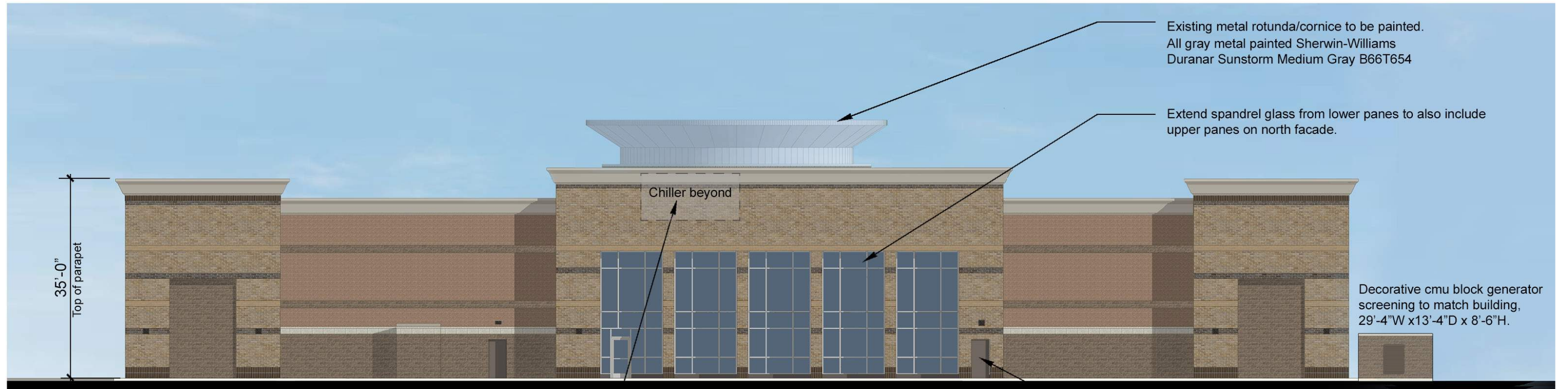

North Elevation

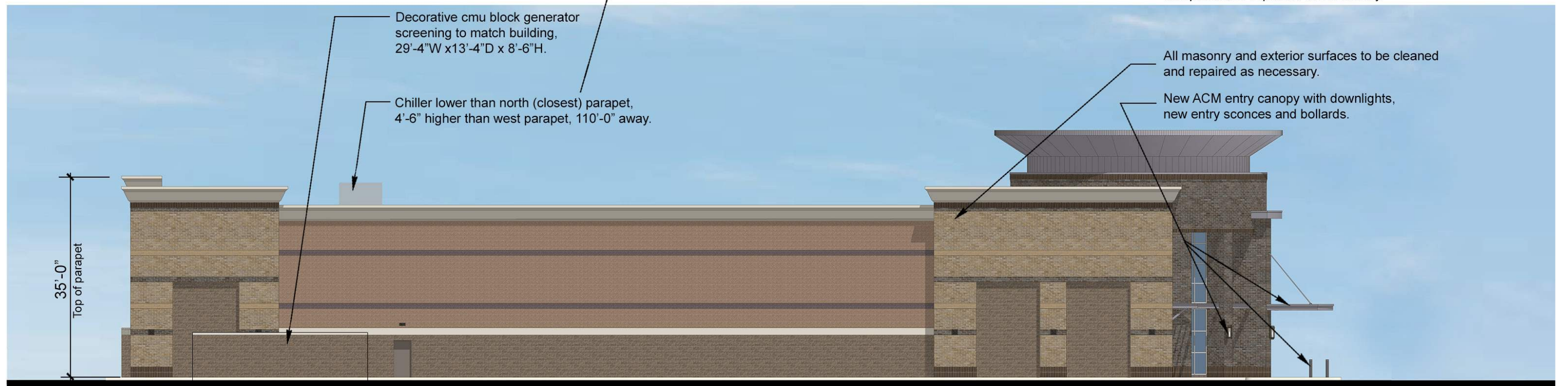

West Elevation



Trash and generator enclosures with split face cmu to match the building. Trash enclosure with steel gate structure with composite wood fronts.

Bollard Cover R-7307

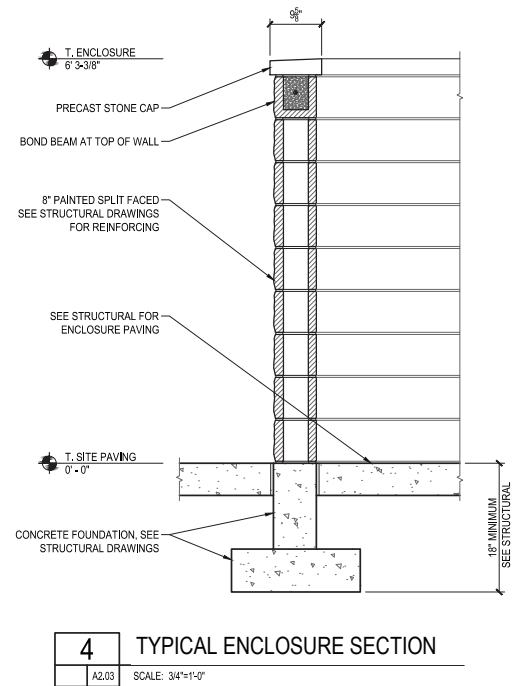
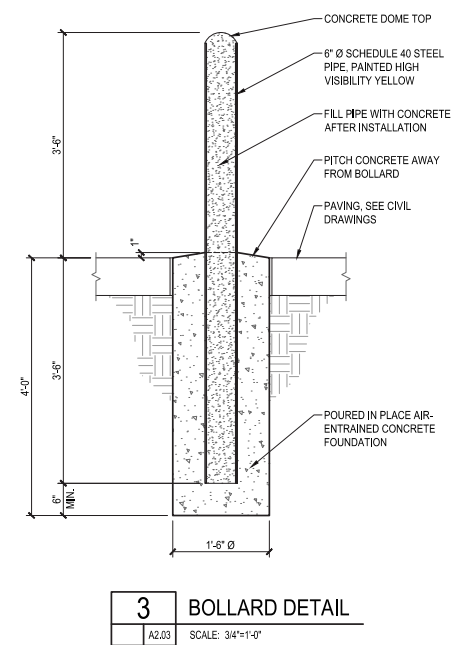
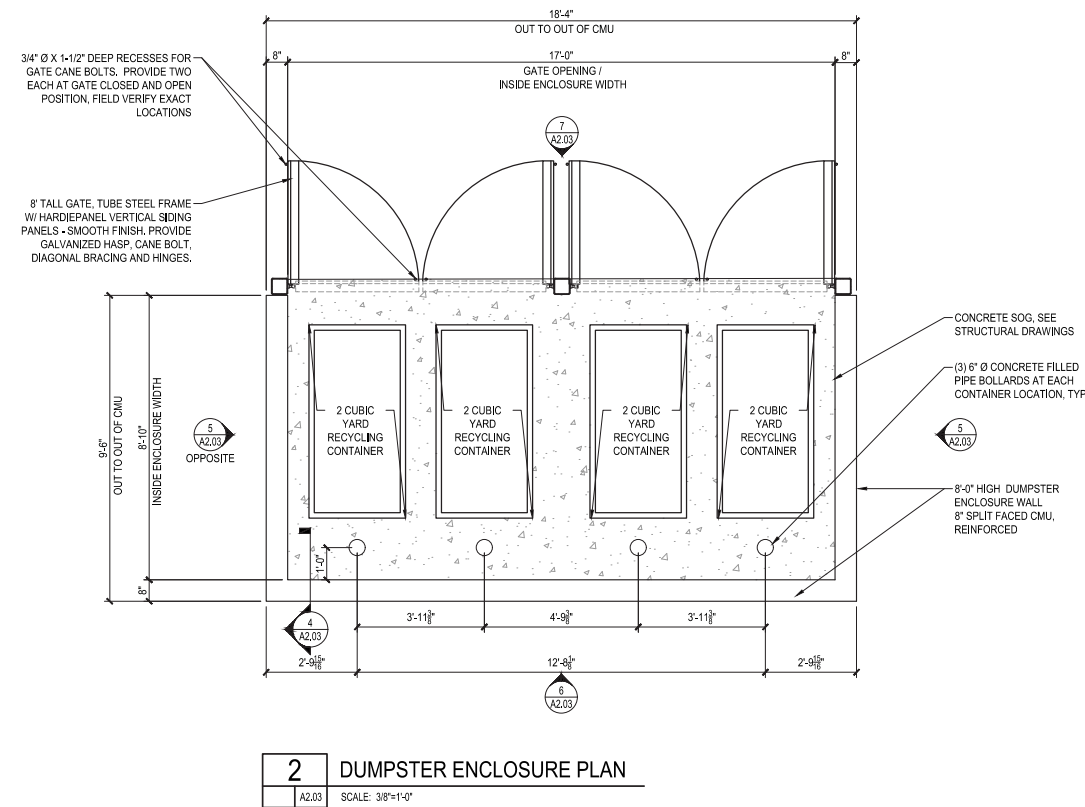
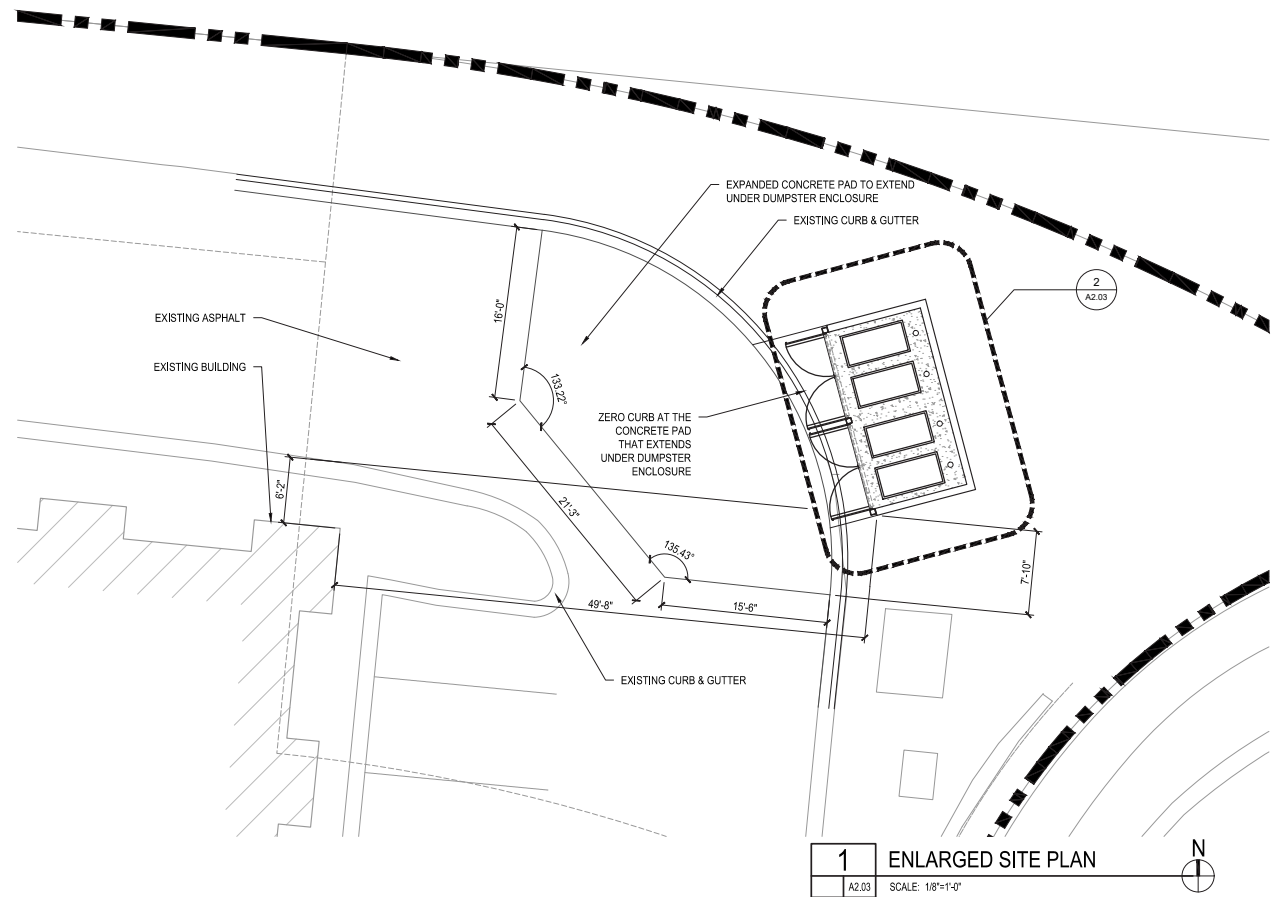
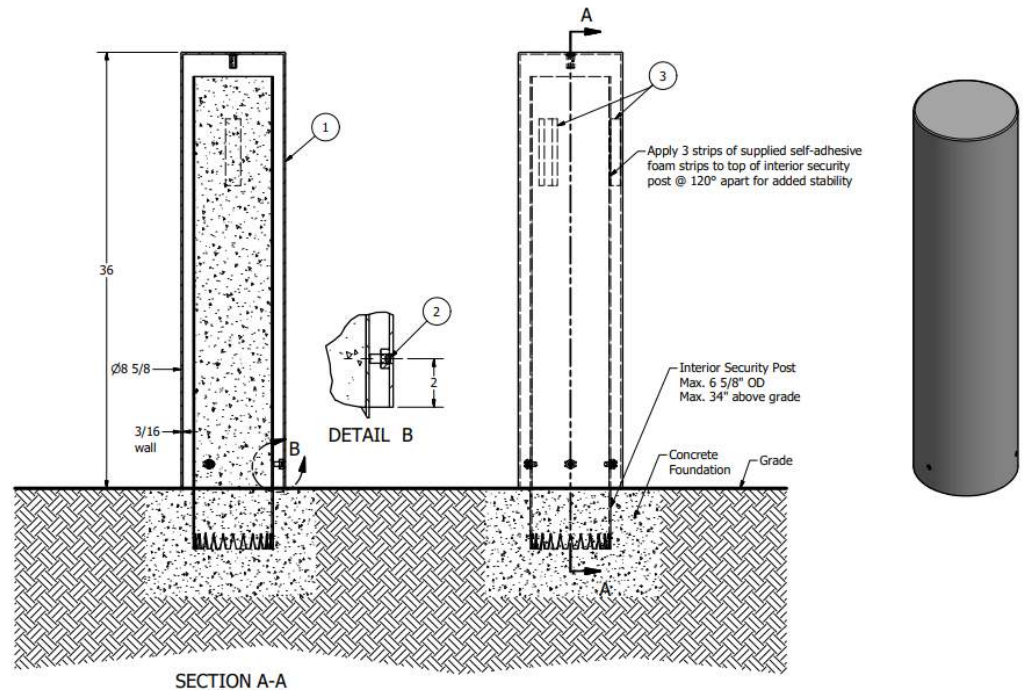



# NAPERVILLE MEDICAL COMMONS

ANTUNOVICH ASSOCIATES • ARCHITECTURE, PLANNING, INTERIOR DESIGN • CAPITAL HEALTHCARE PROPERTIES • DEVELOPER • HITCHCOCK DESIGN GROUP • LANDSCAPE ARCHITECT • V3 • CIVIL ENGINEER

## BUILDING IMAGE

NAPERVILLE, ILLINOIS • FEBRUARY 21, 2024



# NAPERVILLE MEDICAL COMMONS

ANTUNOVICH ASSOCIATES • ARCHITECTURE, PLANNING, INTERIOR DESIGN • CAPITAL HEALTHCARE PROPERTIES • DEVELOPER • HITCHCOCK DESIGN GROUP • LANDSCAPE ARCHITECT • V3 • CIVIL ENGINEER

## BUILDING IMAGE

NAPERVILLE, ILLINOIS • FEBRUARY 21, 2024



# NAPERVILLE MEDICAL COMMONS

ANTUNOVICH ASSOCIATES • ARCHITECTURE, PLANNING, INTERIOR DESIGN • CAPITAL HEALTHCARE PROPERTIES • DEVELOPER • HITCHCOCK DESIGN GROUP • LANDSCAPE ARCHITECT • V3 • CIVIL ENGINEER

## BUILDING IMAGE

NAPERVILLE, ILLINOIS • FEBRUARY 21, 2024



## NAPERVILLE MEDICAL COMMONS

ANTUNOVICH ASSOCIATES • ARCHITECTURE, PLANNING, INTERIOR DESIGN • CAPITAL HEALTHCARE PROPERTIES • DEVELOPER • HITCHCOCK DESIGN GROUP • LANDSCAPE ARCHITECT • V3 • CIVIL ENGINEER

BUILDING IMAGE

NAPERVILLE, ILLINOIS • FEBRUARY 21, 2024