

PRELIMINARY STORMWATER MANAGEMENT REPORT
FOR
THE BELVEDERE
NAPERVILLE, ILLINOIS

TABLE OF CONTENTS

<u>SECTION</u>	<u>PAGE NO.</u>
1.0 PROJECT DESCRIPTION	1 - 2
2.0 FLOODPLAIN AND WETLANDS ASSESSMENT	2 - 3
A. FLOODPLAIN EVALUATION	
B. WETLANDS ASSESSMENT	
3.0 EXISTING “WITHOUT PROJECT” CONDITIONS	3 - 6
A. WATERSHED DESCRIPTION	
B. METHODS	
C. EXISTING CONDITIONS SUMMARY	
4.0 PROPOSED “WITH PROJECT” CONDITIONS	6 - 9
A. DESCRIPTION	
B. HYDROLOGIC ANALYSIS	
5.0 SOIL EROSION AND SEDIMENTATION CONTROL PLAN	9
6.0 SUMMARY	9

PRELIMINARY STORMWATER MANAGEMENT REPORT
FOR
THE BELVEDERE
NAPERVILLE, ILLINOIS

EXHIBITS

EXHIBIT A	LOCATION MAP
EXHIBIT B	FIRM PANEL 17197C0037G
EXHIBIT C	NRCS SOILS MAP
EXHIBIT D	NATIONAL WETLANDS INVENTORY MAP
EXHIBIT E	WETLAND DELINEATION & ASSESSMENT REPORT (BY MIDWEST ECOLOGICAL, INC.)
EXHIBIT F	USACOE JURISDICTIONAL DETERMINATION LETTER
EXHIBIT G	EXISTING CONDITIONS WATERSHED EXHIBIT
EXHIBIT H	EXISTING CONDITIONS HEC-RAS MODEL
EXHIBIT I	EXISTING CONDITIONS FLOODPLAIN CROSS SECTIONS
EXHIBIT J	EXISTING CONDITIONS SUPPORTING CALCULATIONS
EXHIBIT K	EXISTING CONDITIONS PONDPACK MODEL
EXHIBIT L	PROPOSED CONDITIONS WATERSHED EXHIBIT
EXHIBIT M	PROPOSED CONDITIONS SUPPORTING DOCUMENTATION
EXHIBIT N	PROPOSED CONDITIONS PONDPACK MODEL
EXHIBIT O	FLOODPLAIN CUT/FILL CALCULATIONS

**PRELIMINARY STORMWATER MANAGEMENT REPORT
FOR
THE BELVEDERE
NAPERVILLE, ILLINOIS**

1.0 PROJECT DESCRIPTION

The Belvedere Project site proposed by Bridge Capital Partners is a 20.17± acre parcel located north of 111th Street, west of Route 59 in the Will County portion of Naperville (refer to the Project Location Map in Exhibit A). The proposed Project includes the construction of ten (10) apartment buildings and a community clubhouse. 0.91 acres of land will be dedicated as additional Right-of-Way along 111th Street. Site infrastructure improvements (see Preliminary Engineering Plan) will include the construction of sanitary sewers, watermains, stormwater drainage and conveyance facilities, and wetland bottom stormwater management facilities (SWMF) which will be vegetatively stabilized for stormwater discharge control and Best Management Practices. Clow Creek bisects the site into two (2) sections, north and south of the creek. A proposed bridge crossing will be added across Clow Creek to provide access to the northern section of the site. Besides the interior clubhouse features, additional site amenities will include a community pool, playground, dog park and trails around the proposed SWMF. Additionally, the existing tree line along the western property line will largely left undisturbed, as much as possible.

The existing soils on the property consist predominately of silty loam and silty clay loam material, falling in Type B and C classifications. Existing slopes range typically in the 0 to 5% range, with drainage towards Clow Creek. Exhibit B provides the NRCS Soils Map for the Project site.

The purpose of this Stormwater Management Analysis and Report is to summarize the hydrologic and hydraulic analyses performed for Existing and Proposed Conditions and to demonstrate that, when constructed, the development will comply with Naperville, County,

State, and Federal laws and regulations and provide a significant drainage improvement and regional benefit for the watershed.

2.0 FLOODPLAIN AND WETLANDS ASSESSMENT

During the Project-Planning Phase, the subject site was evaluated for the presence of regulatory floodplains/floodways, wetland habitat, and buffers. This evaluation consisted of a detailed review of available Topographic, Wetland, and FEMA Maps. Following is an account of the sources referenced and procedures employed in conducting the assessment for the Project.

A. Floodplain Evaluation

As mentioned in the Project Description above, the site is divided into two (2) sections by Clow Creek. There is Zone AE floodplain associated with Clow Creek as shown in Exhibit B (FIRM Panel 17197C0037G, effective 2/15/2019). The FIRM panel shows that the Base Flood Elevation (BFE) ranges from 654 at the western property limit to approximately 652.1 at the eastern property line. A detailed floodplain analysis of the creek has been performed and is described later in this report. There will be only minor grading operations performed within the floodplain, with the appropriate mitigation provided as necessary. Any required permits from USACOE and/or IDNR-OWR will be obtained during the Final Design process.

B. Wetlands Assessment

Exhibit D provides the USFWS National Wetlands Inventory Map, which does not indicate the presence of wetlands on the site. However, a site wetland delineation was performed by Midwest Ecological, Inc., which did result in three (3) wetlands being located on the site. The first wetland will be Waters of the US given its location along Clow Creek. Wetland A is a pocket wetland located in the central area of the site, but with no direct connection to Clow Creek. The wetland associated with Pond #1 in the center of the site was created by previous excavation and is exempt from federal regulations. A copy of the Wetland Delineation Report is included as Exhibit E. The USACOE Jurisdictional Determination Letter supporting these findings is included in Exhibit F.

The proposed Project improvements do not require a direct impact to Wetland #1 (Waters of the

US). The proposed SWMF discharge locations are designed to pull the bank/discharge elevation further away from the wetland limit. They will result in no fill being placed in the wetland. The proposed bridge crossing will utilize an appropriately sized span (CONSPAN or similar) that will place the footings of the structure outside the limits of the wetland. Any required permits from USACOE and/or IDNR-OWR will be obtained during the Final Design process.

3.0 EXISTING “WITHOUT PROJECT” CONDITIONS

A. Watershed Description

The Project site is a series of commercial greenhouses that have since been closed for business. The site itself is comprised of two (2) major swathes of land straddling the West Tributary of Clow Creek. The commercial development present on the south side of the Creek appears to be mass graded, although large portions of it have been left as undeveloped green space. There is a man-made pond on the northern portion of this part of the development that appears to be storing water exclusively for the purpose of capture, storage, and reuse for onsite horticultural purposes. This pond captures only the area immediately surrounding and including it, totaling 1.52 acres. Onsite overland flow is diverted around the pond and towards the Creek. No pond outlet has been located, but it appears to naturally overflow at the northwest corner. North of the Creek, the site has been mass graded, but has been otherwise left as undeveloped green space.

Stormwater runoff from both north and south portions of the site, totaling 18.58 acres, broadly sheet flows overland and is ultimately tributary to the creek. A 2.94 acre section of the adjacent properties to the west and north are directly tributary to this site, and contribute to this overland, onsite flow. The property to the east contributes a small, 0.13 acre, portion of its site directly onto the south part, which is then tributary to Clow Creek.

The Project onsite area includes three (3) areas that flow offsite to the west, south, and east. The southwest corner of the site, totaling 0.23 acres, flows due west offsite towards a drainage swale on the adjacent property. The eastern half of the berm along the eastern property line, totaling 0.64 acres, is tributary to the lot directly east of it, into what appears to be an existing detention basin. The southern edge of the site, comprising 0.72 acres, is directly tributary to the drainage

ditch in the 111th Street right of way, directing the flow into the village storm sewer. Exhibit G presents the Existing Conditions Watershed for the site area described above, and the tributary offsite areas described in more detail below.

Upstream of the site along the West Tributary of Clow Creek are the tributary areas from 103rd St and 248th Ave, which includes the western half of the Tamarack Golf Club and the southern half of the Ashwood Park Subdivision. The upstream condition has two (2) branches that feed into the pond labeled as TAM-7 in the Existing Conditions Watershed Exhibit. The southern branch is comprised of a series of tributary areas from Ashford Park North and the associated ponds, and tributary to four (4) ponds associated with Tamarack Golf course. The northern branch encompasses the remainder of the ponds and tributary areas from these developments, and also includes previously modeled and approved Creek flows. These Creek flows were previously modeled using HEC-1 and approved by IDNR and FEMA, and when converted to PondPack, these models were approved previously by the City of Naperville. These models include all information for all tributary flows and cross-sections up to 103rd and 248th Streets.

The flow results above have been converted into hydrographs and manually input into a new PondPack model as Creek Outfall 1 and Creek Outfall 2. Both of these branches ultimately flow into Pond TAM-7, which is immediately upstream of this site. TAM-7 outlets into the onsite segment of Clow Creek via a 6'x12' box culvert. The PondPack model incorporates the update to Bulletin 75 rainfalls (Exhibit K).

B. Methods

In accordance with the current Will County Stormwater Ordinance (Ordinance), proposed site development flows must be attenuated to 0.04 cfs/ac. for the 2-Year, 24-Hour and 0.15 cfs/ac. for the 100-Year 24-Hour condition of development area, or below existing conditions peak flows, whichever is more restrictive.

The onsite existing condition for the West Tributary of Clow Creek was established by using the aforementioned upstream flow conditions to establish the upstream flow. Using HEC-RAS 4.1, cross-sections were established using collected topographic information. Downstream conditions

for the Creek slope were used to establish the downstream border conditions and create a rating curve for the Creek. This rating curve was manually input into the upstream flow condition for the existing conditions model and was run to establish the 10-Year and 100-Year peak flows. The known downstream elevations were then taken from FEMA FIS, and the model was rerun to determine flow elevations through the cross-sections (Exhibit H). This was then translated onto the site topographic information to determine the on-site flood-plain elevations, which are shown on Exhibit I

To develop rainfall vs. runoff relationships for the development, the Soil Conservation Service (SCS) method was utilized with the PondPack V8i software and employed the following methodology and procedures in determining the respective hydrologic and hydraulic parameters.

- **Runoff Curve Numbers** – The TR-55 Tables 2-2a (*urban areas*) and 2-2c (*agr. Lands*), "NRCS Web Soil Survey", and watershed land use data were utilized to calculate runoff curve numbers (*CN*) for input to the PondPack Model. A $CN = 98$ was used for all impervious surfaces and the area encompassed by the stormwater management facility (SWMF) and a $CN = 61$ (type B soils) and $CN = 74$ (type C soils) was used for all other landscaped pervious surfaces. This was distributed on the basis of 65% Type B and 35% Type C, based on the NRCS Soil Map for the area. The CN documentation for the Project site is provided in Exhibit J for Existing Conditions and Exhibit M for Proposed Conditions.
- **Time of Concentration** - The Time of Concentration (T_c) was calculated using SCS TR-55 methodology. The T_c calculations were performed for flow paths representing the travel from the hydraulically most distant point of the watershed to the point of interest. The T_c documentation for the Project site is provided in Exhibit J for Existing Conditions and Exhibit M for Proposed Conditions.
- **Precipitation Data/Rainfall Distribution** – Updated Bulletin 75 northeast rainfall values with Huff rainfall distributions were selected in accordance with Appendix E criteria and the "Technical Guidance" to the Ordinance. Storage volumes were evaluated based on the 100-year frequency 24-hour duration event measuring 8.57 inches of precipitation and the Huff 3rd quartile rainfall distribution.

- **Stage vs. Storage and Stage vs. Discharge Relationships** - Stage vs. storage relationships for the SWMF were measured within AutoCAD at regular intervals corresponding to the level of potential inundation, and the volume was calculated by the method of average area times the incremental interval. For offsite areas, CEMCON Ltd. surveyed the upstream reservoirs' outlet control structures and supplemented the Plans with County topography to develop stage-storage and stage-discharge relationships. Stage vs. discharge relationships were developed in PondPack for all possible combinations of headwater and tailwater. PondPack was then run dynamically to evaluate the headwater and tailwater at each time step to determine the flow through each structure. Supporting documentation is provided in Exhibit J for Existing Conditions and Exhibit M for Proposed Conditions.

C. Existing Conditions Summary

The Existing Conditions model was run for the 2-Year and 100-Year 1-Hour events through the 24-Hour events. The 2-Year 18-Hour event and 100-Year 18-Hour event were determined to be the critical duration event leaving the site, generating the highest peak flow. The numerical results are summarized along with the proposed results in Table 3 in Section 4.0 below. Refer to Exhibit K for the PondPack model input and output for key events.

4.0 PROPOSED "WITH PROJECT" CONDITIONS

A. Description

In accordance with the City of Naperville and Will County Stormwater Management Ordinance, any proposed site development which would affect the discharge of stormwater requires stormwater management to protect downstream properties. In general, Stormwater Management Facilities (SWMF) are configured to restrict site runoff to 0.04 cfs/acre for the 2-Year event and the 100-Year event to 0.15 cfs/ac., or less than existing conditions, whichever is more restrictive.

The Belvedere will incorporate two (2) SWMFs (refer to Exhibit L for the Proposed Conditions Watershed Exhibit). Proposed SWMF North is located in the northeastern corner of the site and will receive flow from the proposed development north of Clow Creek. The proposed conditions for the northern development will require a maximum HWL at 653.3 with 1.00 ac.-ft. of storage. The pond was designed for a HWL of 654.0 and provides 1.27 ac.-ft. of storage, exceeding

requirements. SWMF South is located at the north east corner of the southern portion of the development, along the creek. The southern portion of the area is directly tributary to this pond and will require a HWL of 654.4 and 6.42 ac.-ft. of storage. The proposed condition has a design HWL at 654.5 and maintains 6.60 ac.-ft. of storage at this elevation, exceeding requirements. Overflow weirs are provided from both facilities capable of conveying a minimum of 1 cfs/acre with less than one foot of depth, in accordance with the Will County Stormwater Ordinance. Overflow weir calculations are provided in Exhibit M.

The existing pond located centrally on the Project site will be removed, and a larger wetland bottom SWMF will be constructed in that location (SWMF South). Since the existing pond did not have a gravity outlet, it meets the criteria in the Will County Stormwater Ordinance of an existing depression. However, there is no offsite area tributary to the existing pond (in fact, as described in the existing conditions above there is only small onsite area tributary to the pond). As such, the proposed SWMF will preserve (and expand) on the function of the existing depression, thereby satisfying the criteria of the County Stormwater Ordinance and no compensatory storage shall be required.

B. Hydrologic Analysis

As previously stated, the site runoff for the development has been documented to be in strict conformance with the Ordinance. The Proposed Conditions PondPack Model (Exhibit N) which accounts for the construction of the proposed stormwater management facilities on the site and the proposed land use has been prepared. This stormwater management analysis was performed to quantify stormwater storage requirements and ensure that the required release rates are met in the proposed condition. The proposed release rates were calculated by adding the onsite allowable release rates (0.15 cfs/ac. for the 100-Year 24-Hour and 0.04 cfs/ac. for the 100-Year 24-Hour) to establish the allowable release rate for the site. Refer to Tables 1 and 2 for the allowable release rate calculations. Refer to Table 3 for a comparison between the existing and proposed total peak flows for the 2-Year and 100-Year 1-Hour through 24-Hour events. See Exhibit N for the “PROP” PondPack Model and Output.

Table 1: Allowable Release (100-Year, 24-Hour Event)

	DURATION
100-Year	24-Hour
Dev. Area Allowable Release (cfs/ac.)	0.15
Development Area (ac.)	15.92
(A) Development Allowable Release (cfs)	2.39
(B) By-Pass Flow (Subarea 302) (cfs)	0.46
(A+B) Total Allowable Release (cfs)	2.85
Prop. Release (North+South) (cfs)	2.72

Table 2: Allowable Release (2-Year, 24-Hour Event)

	DURATION
2-Year	24-Hour
Dev. Area Allowable Release (cfs/ac.)	0.04
Development Area (ac.)	15.92
(A) Development Allowable Release (cfs)	0.64
(B) By-Pass Flow (Subarea 302) (cfs)	0.08
(A+B) Total Allowable Release (cfs)	0.72
Prop. Release (North+South) (cfs)	0.70

Table 3: Total Peak Discharge (cfs) Summary

Event	1-Hr	2-Hr	3-Hr	6-Hr	12-Hr	18-Hr	24-Hr
100-Year							
Proposed Peak Discharge (cfs)	2.34	2.50	2.53	2.59	2.75	2.74	2.72
Existing Peak Discharge (cfs)	48.26	47.8	43.28	31.39	22.14	18.46	19.33
2-Year							
Proposed Peak Discharge (cfs)	0.40	0.48	0.50	0.55	0.57	0.61	0.70
Existing Peak Discharge (cfs)	4.24	4.77	4.62	4.21	4.13	4.10	5.09

As evidenced by the results, the proposed improvements significantly reduce peak flows leaving the site. The critical events in proposed conditions are now the 2-Year 24-Hour event and the 100-Year, 12-Hour event.

There is a small amount of floodplain fill as a result of the proposed development. Compensatory storage has been provided at a 1:1 ratio as required by the Will County Stormwater Ordinance. The Floodplain Cut/Fill Calculations are provided in Exhibit O.

5.0 SOIL EROSION AND SEDIMENTATION CONTROL PLAN

Soil erosion and sediment control measures will be proposed to protect downstream properties and the Special Management Areas from adverse effects of soil erosion and sedimentation. The proposed erosion and sediment control features will include:

- Storm sewer inlets protected with sediment trapping/filter control devices during construction.
- Silt fencing installed along the site perimeter and a double row of silt fence along wetland, buffer and floodplain areas.
- Construction entrance(s) will be implemented to minimize the impact to adjacent roadways.
- Temporary triangular silt dikes within the drainage swales.
- Disturbed areas permanently seeded and protected from soil erosion after final grading is accomplished.

6.0 SUMMARY

A hydrologic analysis was performed utilizing PondPack to verify compliance with the County Ordinance. The stormwater management systems proposed meet and exceed the requirements of Will County. Additionally, as demonstrated by the PondPack model results, the proposed development will significantly reduce flows downstream and provide a net watershed benefit.

EXHIBIT A
LOCATION MAP

AERIAL LOCATION MAP
THE BEVERLY



PROJECT LOCATION

EXHIBIT B

FIRM PANEL 17197C0037G

National Flood Hazard Layer FIRMMette



88°12'57"W 41°41'8"N

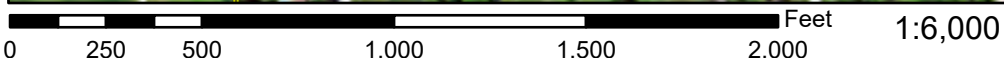
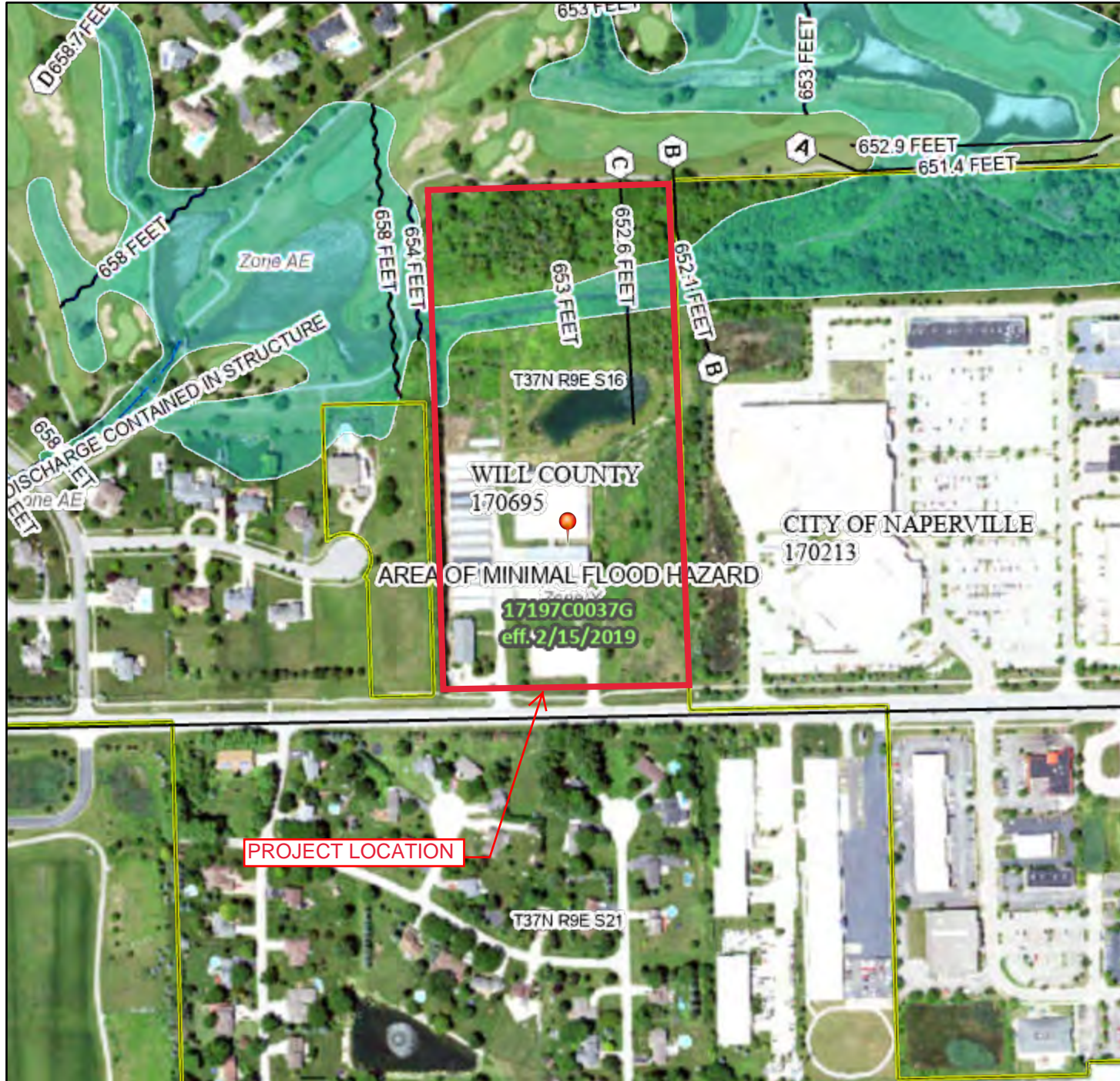

Basemap: USGS National Map: Orthoimagery: Data refreshed October, 2020

Legend

SEE FIS REPORT FOR DETAILED LEGEND AND INDEX MAP FOR FIRM PANEL LAYOUT

SPECIAL FLOOD HAZARD AREAS	Without Base Flood Elevation (BFE) Zone A, V, A99	With BFE or Depth Zone AE, AO, AH, VE, AR	Regulatory Floodway

OTHER AREAS OF FLOOD HAZARD	0.2% Annual Chance Flood Hazard, Areas of 1% annual chance flood with average depth less than one foot or with drainage areas of less than one square mile Zone X	Future Conditions 1% Annual Chance Flood Hazard Zone X	Area with Reduced Flood Risk due to Levee. See Notes. Zone X	Area with Flood Risk due to Levee Zone D

OTHER AREAS	NO SCREEN Area of Minimal Flood Hazard Zone X	Effective LOMRs	Area of Undetermined Flood Hazard Zone D

GENERAL STRUCTURES	Channel, Culvert, or Storm Sewer	Levee, Dike, or Floodwall

OTHER FEATURES	20.2 Cross Sections with 1% Annual Chance Water Surface Elevation	17.5 Coastal Transect	Base Flood Elevation Line (BFE)	Limit of Study	Jurisdiction Boundary	Coastal Transect Baseline	Profile Baseline	Hydrographic Feature

MAP PANELS	Digital Data Available	No Digital Data Available	Unmapped

The pin displayed on the map is an approximate point selected by the user and does not represent an authoritative property location.

This map complies with FEMA's standards for the use of digital flood maps if it is not void as described below. The basemap shown complies with FEMA's basemap accuracy standards

The flood hazard information is derived directly from the authoritative NFHL web services provided by FEMA. This map was exported on **3/22/2022 at 10:38 AM** and does not reflect changes or amendments subsequent to this date and time. The NFHL and effective information may change or become superseded by new data over time.

This map image is void if the one or more of the following map elements do not appear: basemap imagery, flood zone labels, legend, scale bar, map creation date, community identifiers, FIRM panel number, and FIRM effective date. Map images for unmapped and unmodernized areas cannot be used for regulatory purposes.



EXHIBIT C

NRCS SOILS MAP

Hydrologic Soil Group—Will County, Illinois
(THE BELVEDERE)



Soil Map may not be valid at this scale.

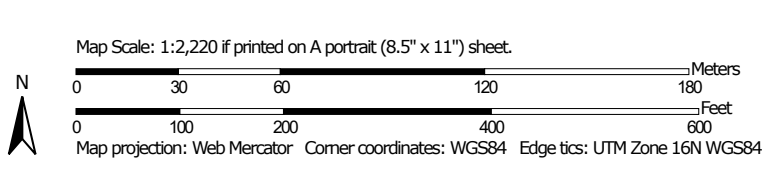

MAP LEGEND

Area of Interest (AOI)









 Area of Interest (AOI)

Soils

Soil Rating Polygons





 A
 A/D
 B
 B/D
 C
 C/D
 D
 Not rated or not available

Soil Rating Lines

 A
 A/D
 B
 B/D
 C
 C/D
 D
 Not rated or not available

Soil Rating Points





 A
 A/D
 B
 B/D

 C
 C/D
 D
 Not rated or not available

Water Features

 Streams and Canals

Transportation

 Rails
 Interstate Highways
 US Routes
 Major Roads
 Local Roads

Background

 Aerial Photography

MAP INFORMATION

The soil surveys that comprise your AOI were mapped at 1:12,000.

Warning: Soil Map may not be valid at this scale.

Enlargement of maps beyond the scale of mapping can cause misunderstanding of the detail of mapping and accuracy of soil line placement. The maps do not show the small areas of contrasting soils that could have been shown at a more detailed scale.

Please rely on the bar scale on each map sheet for map measurements.

Source of Map: Natural Resources Conservation Service
 Web Soil Survey URL:
 Coordinate System: Web Mercator (EPSG:3857)

Maps from the Web Soil Survey are based on the Web Mercator projection, which preserves direction and shape but distorts distance and area. A projection that preserves area, such as the Albers equal-area conic projection, should be used if more accurate calculations of distance or area are required.

This product is generated from the USDA-NRCS certified data as of the version date(s) listed below.

Soil Survey Area: Will County, Illinois
 Survey Area Data: Version 16, Aug 31, 2021

Soil map units are labeled (as space allows) for map scales 1:50,000 or larger.

Date(s) aerial images were photographed: Jun 18, 2020—Jul 3, 2020

The orthophoto or other base map on which the soil lines were compiled and digitized probably differs from the background imagery displayed on these maps. As a result, some minor shifting of map unit boundaries may be evident.

Hydrologic Soil Group

Map unit symbol	Map unit name	Rating	Acres in AOI	Percent of AOI
356A	Elpaso silty clay loam, 0 to 2 percent slopes	B/D	12.7	63.4%
541B	Graymont silt loam, 2 to 5 percent slopes	C	5.7	28.5%
614A	Chenoa silty clay loam, 0 to 2 percent slopes	C/D	0.7	3.6%
W	Water		0.9	4.5%
Totals for Area of Interest			20.0	100.0%

Description

Hydrologic soil groups are based on estimates of runoff potential. Soils are assigned to one of four groups according to the rate of water infiltration when the soils are not protected by vegetation, are thoroughly wet, and receive precipitation from long-duration storms.

The soils in the United States are assigned to four groups (A, B, C, and D) and three dual classes (A/D, B/D, and C/D). The groups are defined as follows:

Group A. Soils having a high infiltration rate (low runoff potential) when thoroughly wet. These consist mainly of deep, well drained to excessively drained sands or gravelly sands. These soils have a high rate of water transmission.

Group B. Soils having a moderate infiltration rate when thoroughly wet. These consist chiefly of moderately deep or deep, moderately well drained or well drained soils that have moderately fine texture to moderately coarse texture. These soils have a moderate rate of water transmission.

Group C. Soils having a slow infiltration rate when thoroughly wet. These consist chiefly of soils having a layer that impedes the downward movement of water or soils of moderately fine texture or fine texture. These soils have a slow rate of water transmission.

Group D. Soils having a very slow infiltration rate (high runoff potential) when thoroughly wet. These consist chiefly of clays that have a high shrink-swell potential, soils that have a high water table, soils that have a claypan or clay layer at or near the surface, and soils that are shallow over nearly impervious material. These soils have a very slow rate of water transmission.

If a soil is assigned to a dual hydrologic group (A/D, B/D, or C/D), the first letter is for drained areas and the second is for undrained areas. Only the soils that in their natural condition are in group D are assigned to dual classes.

Rating Options

Aggregation Method: Dominant Condition

Component Percent Cutoff: None Specified

Tie-break Rule: Higher

EXHIBIT D

NATIONAL WETLANDS INVENTORY MAP

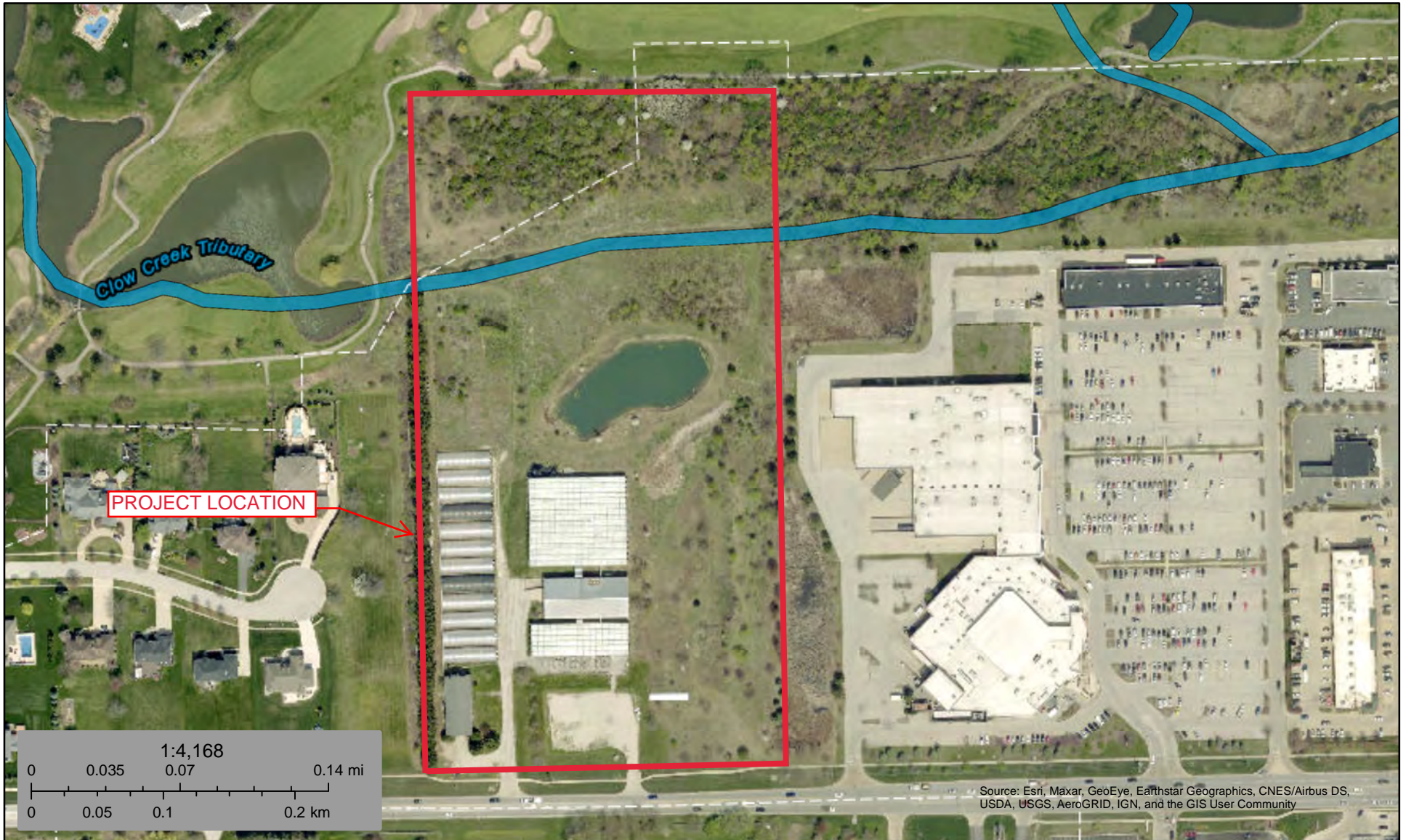

December 8, 2021

Wetlands

- | | | | | | |
|---|--------------------------------|---|-----------------------------------|---|----------|
|  | Estuarine and Marine Deepwater |  | Freshwater Emergent Wetland |  | Lake |
|  | Estuarine and Marine Wetland |  | Freshwater Forested/Shrub Wetland |  | Other |
| | |  | Freshwater Pond |  | Riverine |

This map is for general reference only. The US Fish and Wildlife Service is not responsible for the accuracy or currentness of the base data shown on this map. All wetlands related data should be used in accordance with the layer metadata found on the Wetlands Mapper web site.

EXHIBIT E

WETLAND DELINEATION & ASSESSMENT
REPORT (BY MIDWEST ECOLOGICAL, INC.)

WETLAND DELINEATION REPORT

PREPARED FOR:

LENNAR®

SUBJECT SITE:

Lizzie's Garden
Naperville, Will County, Illinois.
Latitude 41.682000 - Longitude -88.210853

October 28, 2020



PO BOX 321 | GILBERTS, ILLINOIS 60136 | 847-514-5476

TABLE OF CONTENTS

	<i>Page</i>
EXECUTIVE SUMMARY	1
PURPOSE OF VISIT	1
DEFINITION OF A WETLAND.....	1
METHODOLOGY	2
LOCATION MAP	3
NATIONAL WETLAND INVENTORY MAP.....	4
WILL COUNTY SOIL SURVEY MAP	4
UNITED STATES GEOLOGICAL & HYDROLOGICAL SURVEY MAPS.....	4
FLOOD INSURANCE RATE MAP.....	4
WETLAND FIELD DELINEATION.....	4
CONCLUSION.....	7
FEDERAL REGULATIONS	8
 APPENDIX A	 <i>Exhibit</i>
WETLAND AERIAL PHOTOGRAPH.....	1
WETLAND BOUNDARY MAP PREPARED BY MACKIE CONSULTING.....	2
1974 HISTORICAL AERIAL PHOTOGRAPH.....	3
1988 HISTORICAL AERIAL PHOTOGRAPH.....	4
LOCATION MAP	5
2020 NATIONAL WETLAND INVENTORY MAP.....	6
1978 HISTORICAL NATIONAL WETLAND INVENTORY MAP.....	7
2020 WILL COUNTY SOIL SURVEY MAP	8
1981 HISTORICAL WILL COUNTY SOIL SURVEY MAP	9
UNITED STATES GEOLOGICAL SURVEY MAP.....	10
HYDROLOGICAL ATLAS.....	11
FLOOD INSURANCE RATE MAP (F.I.R.M.).....	12
 APPENDIX B	
PHOTOGRAPHS.....	1-2
 APPENDIX C	
DATA SHEETS.....	1A-4A
 APPENDIX D	
HABITAT SCORE SHEET.....	1-3

WETLAND DELINEATION REPORT

EXECUTIVE SUMMARY

In response to the request of Lennar Homes, Midwest Ecological, Inc. (MEI) has performed and completed a Wetland Delineation for the approximate 20 acre Lizzies Garden nursery located 24251 111th Street. The 20 acre farm is geographically located with at the SE Section 16, Township 37 North, Range 9 East of the Third Principal Meridian within Naperville, Will County, Illinois. Utilizing the methods and criteria established by the U.S. Army Corps of Engineers (COE) in their Corps of Engineers Wetlands Delineation Manual (1987), Midwest Regional Supplement (2008) and United States Department of Agriculture/Natural Resource Conservation Service, in their Wetland Mapping Conventions – NRCS, Illinois (1998) a wetland investigation of the property was performed. Based on the on-site investigation using the information obtained from the field samples Midwest Ecological, Inc. (MEI) identified one (1) Waters of the United States, one (1) open water pond and one (1) wetland totaling **1.4 acres** in size.

Site	Size	Mean C	FQI	Anticipated Regulatory Agency
WOUS #1 (Clow Creek)	0.26 acres	2.06	8.24	Corps of Engineers
Pond #1	0.82 acres	*	*	Exempt Waters
Wetland A	0.36 acres	2.44	7.33	Isolated Wetland of Will County

Please Note: Clow Creek is larger than noted within this report. The acreages and quality of natural resources only pertain to the study area.

It should be noted that under the current guidelines, any disturbance of a wetland area requires a permit (L.O.N.O, RPP or IP). However, mitigation may or may not be required, depending on the overall impact (> 0.10) to the wetland or Waters of the United States. This determination is at the discretion of the COE, Will County or the City of Naperville.

PURPOSE OF VISIT

The purpose of the site visit is to determine if any Wetlands (various types), Open water pockets, Creeks or Rivers exist on-site and to determine their approximate size, location, quality and jurisdiction. Wetlands encountered were delineated using standard methods sanctioned by the United States Army Corps of Engineers in their Corps of Engineers Wetlands Delineation Manual (1987), Regional Supplement (2008) and Wetland Mapping Conventions – NRCS, Illinois (1998).

DEFINITION OF A WETLAND

The U.S. Army Corps of Engineers (ACOE) and the U.S. Environmental Protections Agency (EPA) define wetlands as:

“areas that are inundated or saturated by surface or groundwater at a frequency and duration sufficient to support, and that under normal circumstances do support, a prevalence of vegetation typically adapted for life in saturated soil conditions...” (33 CFR 328.3[b], 1977).

Although not defined by regulation, “normal circumstances” are interpreted by both the ACOE and the Natural Resources Conservation Service to be “the soil and hydrologic conditions that are normally present, without regard to whether the vegetation has been removed” (7 CFR 12.31[b][2][i]).

METHODOLOGY

Prior to visiting the site, Midwest Ecological, Inc. (MEI) performed a review of the aforementioned National Wetland Inventory maps, Will County Soil Survey map and aerial photograph in order to determine existing site conditions. Site visits were then conducted by an Environmental Wetland Specialist from MEI on August 20 And October 8, 2020. The USACE Wetland Delineation Manual, dated January 1987, identifies the mandatory technical criteria for wetland identification. The three essential characteristics of a wetland are: 1) hydrophytic vegetation; 2) hydric soils; and 3) wetland hydrology. These characteristics are described below:

Hydrophytic Vegetation: The hydrophytic vegetation criterion is based on a separation of plants into five basic groups:

- 1) Obligate wetland plants (OBL) almost always occur (estimated probability >99%) in wetlands under natural conditions;
- 2) Facultative wetland plants (FACW) usually occur in wetlands (estimated probability 67-99%), but occasionally are found in non-wetlands;
- 3) Facultative plants (FAC) are equally likely to occur in wetland or non-wetlands (estimated probability 34-66%);
- 4) Facultative upland plants (FACU) usually occur in non-wetlands (estimated probability 67-99%), but occasionally are found in wetlands (estimated probability 1-33%); and
- 5) Obligate upland plants (UPL) almost always occur (estimated probability >99%) in non-wetlands under natural conditions.

Within each data point, vegetation is sampled in plots of varying size based on the type of vegetation being sampled. The following plot sizes are recommended by the 2010 Regional Supplement to the Corps of Engineers Wetland Delineation Manual for the Midwest Region:

Trees	- 30-ft radius
Saplings/Shrubs	- 15-ft radius
Herbaceous Plants	- 1 m ² plot
Woody vines	- 30-ft radius

If greater than 50% of the plants present in each stratum or layer of the plant community are FAC (with the exception of FAC-), FACW, or OBL the subject area is considered a wetland in terms of vegetation (Dominance Test). If the vegetation does not meet the requirements of the

Dominance Test, the Prevalence Index (PI) should be utilized. The PI evaluates the coverage, on a weighted basis of coverage over all strata, of the vegetation within the plot. The PI ranges between 1.0 and 5.0, with a 3.0 or less indicating hydrophytic vegetation is present. If the PI is greater than 3.0, the dominance test is failed, but there are still hydric soil and wetland hydrology presence, the observation of morphological adaptations by vegetation can be used to indicate that the hydrophytic vegetation criteria is met.

Morphological adaptations are changes in the structure of vegetation in response to conditions outside the normal character of the plant. These adaptations include adventitious roots, multi-stemmed trunks, shallow root systems developed at or near the surface, and buttressing in tree species. To meet this indicator, more than 50% of the individuals of FACU species must exhibit the morphological adaptations. Care must be given that the adaptations observed are due wetter conditions that the species is used to as opposed to other factors such as shallow roots present because of erosion of the surface.

Hydric Soils: Hydric soils are defined in the manual as "soils that are saturated, flooded or ponded long enough during the growing season to develop anaerobic conditions in the upper part." Hydric soil indicators are distinctive characteristics that persist in the soil during both wet and dry periods, and are used to identify hydric soils in the field. Field indicators include color, mottling, gleying, and sulfidic odor. A specific set of indicators has been developed by the USDA Natural Resource Conservation Service (Field Indicators of Hydric Soils in the United States) which provides a detailed description of how to identify the indicators in during a site visit. A soil meets the definition of a hydric soil if it exhibits at least one of these indicators.

Wetland Hydrology: Indicators of hydric soil and hydrophytic vegetation typically reflect the middle and long-term conditions of a site, but not the short term conditions. The wetland hydrology criterion is often the most difficult to determine because of climatological variation. Typically, the presence of water for a week or more during the growing season creates anaerobic conditions indicative of wetland hydrology. Anaerobic conditions lead to the prevalence of wetland plants. The 2010 USACE Regional Supplement for the Midwest Region provides specific indicators in four different groups for wetland hydrology: Observation of Surface Water or Saturated Soils, Evidence of Recent Inundation, Evidence of Current or Recent Soil Saturation, and Evidence from Other Site Conditions or Data. If a site exhibits 1 primary indicator or 2 secondary indicators, then it meets the hydrology criteria for a wetland.

REFERENCE MATERIALS

The following materials were reviewed and utilized to assist in the field reconnaissance and completion of this report. See Appendix A-D for the Reference Materials

Location

The 20 acre nursery located 24251 111th Street. Geographically located with at the SE Section 16, Township 37 North, Range 9 East of the Third Principal Meridian within Naperville, Wheatland Township, Will County, Illinois (Latitude 41.682000 - Longitude -88.210853).

National Wetland Inventory Map

The National Wetland Inventory Map were reviewed to determine the location of wetland areas on the subject site. It should be noted that these maps are only large scale guides, actual wetland locations and types may vary. Ultimate qualification occurs during field reconnaissance.

Per our review of the NWI map, the study area does contain a wetland area.

R2UBHx: Riverine, Lower Perennial, Unconsolidated Shore, Permanently Flooded, excavated.

Will County Soil Survey Map

The Soil Survey of Will County, Illinois was investigated to determine the location of hydric soils on the subject site. Mapped hydric soils can indicate wetland areas. The following soils were found to be present on the subject site during our investigation.

- 356 A – Elpaso silty clay loam, 0-2% slopes (poorly drained, hydric)
- 541 B – Graymont silt loam, 2-5 % slope (moderately well drained)
- 614 A – Chenoa silty clay loam, 0-2 % slopes (somewhat poorly drained)
- W – Water

United States Geological Survey Map

The United States Geological Survey Map & Hydrological Atlas (HA-210) as illustrated on the Normantown Quadrangle U.S.G.S. Map and Hydrological Atlas. These maps were reviewed to determine the historical local drainage patterns. Upon review of this drainage pattern, it appears that the site drains in conveyed to Clow Creek.

Flood Insurance Rate Map

The Flood Insurance Rate Maps (F.I.R.M.), for Will County, Illinois, Community Panel No. 17197C0037 G effective date February 15, 2019 was reviewed to determine the location of regulatory floodplains and floodways within the subject site. Mapped floodplains can be indicative of wetland hydrology.

Based on the F.I.R.M. Map, the study area does contain a Zone AE floodplain zone along and adjacent to Clow Creek.

WETLAND FIELD DELINEATION

An on-site wetland delineation of the property was conducted on August 20 And October 8, 2020. Wetland boundaries were determined using the ACOE guidelines and the United States Department of Agriculture (USDA), Natural Resources Conservation Service (NRCS) guidelines, as stated previously. The routine method of wetland delineation was used, incorporating information on vegetation, hydrology and soils. The full width of the property was traversed and when a suspected wetland was encountered, the plant species present were determined by making

several random passes through the area. If wetland plant species were found to be comprised of 50% or more of plant cover (i.e., wetland vegetation was dominant), the suspected wetland was further examined for the necessary field indicators of hydric soil and hydrology. The wetland boundaries were then defined and all observed plant species were recorded.

The plant taxonomic nomenclature and the Natural Area Index (NAI) used in this report follow's the Chicago Region FQA Index (2017). A more detailed survey would be necessary for a more complete plant list and while more species might be obtained from additional surveys, this would not change the areas delineated as wetlands.

Study Area: The 20 acre nursery is abandon but the nursery buildings and green houses are still present.

Clow Creek (WOUS #1): Clow Creek is a channelized drainage ditch that conveys stormwater flow from west to east. Clow Creek is a tributary to the DuPage River. Flow clearly surges during weather events but does appear to have a low-level base flow consistent with a perennial stream. The portion of the delineated stream is an open water, relatively flat bottom with eroded side slopes. Minor erosion, siltation, sediment and other debris was noted within the established boundary. Shoreline collapse was also noted within the boundary of the ditch along with visible 1:1 and 2:1 slopes. The delineated creek is defined by bed and bank via Ordinary High Water Mark (OHWM). The flagged boundary, found within the study area, is **0.26 acres** in size.

The delineated boundary was evaluated via bed and bank however some vegetation was evaluated observed on and along the bank. The dominant vegetation found within the bank was determined to be Sandbar willow (*Salix interior*), Panic Grass (*Panicum virgatum*) and Fuller's Teasel (*Dipsacus fullonum*). During our investigation positive wetland hydrology is met with the primary indicators of Surface Water (A1), Saturation (A3), Inundation Visible on Aerial Imagery (B7) and secondary indicator of Drainage Patterns (B10). Mapped soil is identified as Elpaso silty clay loam (356 A). Elpaso silty clay loam is a poorly drained hydric soils.

Study Information

Site: Lizzie's Garden
 Locale: Clow Creek (WOUS #1)
 By: Robert Vanni

Conservatism-Based Metrics

Mean C (native species)	2.06
Mean C (all species)	1.67
Mean C (native trees)	3.33
Mean C (native shrubs)	1.00
Mean C (native herbaceous)	2.00
FQAI (native species)	8.24
FQAI (all species)	7.64
Adjusted FQAI	17.97
% C value 0	0.38
% C Value 1-3	0.43

Additional Metrics

Species Richness (all)	21.00
Species Richness (native)	16.00
% Non-native	0.24
Wet Indicator (all)	-0.62
Wet Indicator (native)	-0.82
% hydrophyte (Midwest)	0.76
% native perennial	0.67
% native annual	0.10
% annual	0.10
% perennial	0.86

% C value 4-6	0.10
% C value 7-10	0.05

Species Acronym	Species Name (NWPL/Mohlenbrock)	Common Name	C Value	Midwest WET indicator	WET indicator (numeric)	Habit	Duration	Nativity
aceneg	<i>Acer negundo</i>	Ash-Leaf Maple	0	FAC	0	Tree	Perennial	Native
asesyr	<i>Asclepias syriaca</i>	Common Milkweed	0	FACU	1	Forb	Perennial	Native
broine	<i>Bromus inermis</i>	Smooth Brome	0	FACU	1	Grass	Perennial	Adventive
crarv	<i>Cirsium arvense</i>	Canadian Thistle	0	FACU	1	Forb	Perennial	Adventive
corrac	<i>Cornus racemosa</i>	Gray Dogwood	1	FAC	0	Shrub	Perennial	Native
cypstr	<i>Cyperus strigosus</i>	Straw-Color Flat Sedge	1	FACW	-1	Sedge	Perennial	Native
echeru	<i>Echinochloa crus-galli</i>	Large Barnyard Grass	0	FACW	-1	Grass	Annual	Native
helgro	<i>Helianthus grosseserratus</i>	Saw-Tooth Sunflower	2	FACW	-1	Forb	Perennial	Native
leeoxy	<i>Leersia oryzoides</i>	Rice Cut Grass	4	OBL	-2	Grass	Perennial	Native
polpen	<i>Persicaria pensylvanica</i>	Pinkweed	0	FACU	1	Forb	Annual	Native
phaaru	<i>Phalaris arundinacea</i>	Reed Canary Grass	0	FACW	-1	Grass	Perennial	Adventive
potill	<i>Potamogeton illinoensis</i>	Illinois Pondweed	7	OBL	-2	Forb	Perennial	Native
quebic	<i>Quercus bicolor</i>	Swamp White Oak	6	FACW	-1	Tree	Perennial	Native
rhacat	<i>Rhamnus cathartica</i>	European Buckthorn	0	FAC	0	Shrub	Perennial	Adventive
salint	<i>Salix interior</i>	Sandbar Willow	1	FACW	-1	Shrub	Perennial	Native
salmig	<i>Salix nigra</i>	Black Willow	4	OBL	-2	Tree	Perennial	Native
samcan	<i>Sambucus nigra ssp. canadensis</i>	Black Elder	1	FACW	-1	Shrub	Perennial	Native
astsim	<i>Symphoricarpos lanceolatus</i>	White Petaled American-Aster	3	FAC	0	Forb	Perennial	Native
typlat	<i>Typha latifolia</i>	Broad-Leaf Cat-Tail	1	OBL	-2	Forb	Perennial	Native
urtdio	<i>Urtica dioica ssp. gracilis</i>	Tall Nettle	2	FACW	-1	Forb	Perennial	Native
vitrip	<i>Vitis riparia</i>	River-Bank Grape	2	FACW	-1	Vine	Perennial	Native

Clow Creek Jurisdictional Determination Opinion: Clow Creek is directly connected to the DuPage River and is under the Chicago District Corps of Engineer jurisdiction.

Wetland A: Wetland A is found on the east portion of the site, south of Pond #1. The wetland consists of an emergent pocket. The delineated boundary contained areas of saturation as well as some eroded areas due to storm sewer discharge from the main greenhouse building from the west. The wetland is surrounded by the green houses to the west and a large soil stockpile to the east. It appears that the wetland may have been historically excavated. Wetland A is characterized by data point 1A & 3A and, within the property limits, the wetland acreage is **0.36 acres** in size.

The dominant vegetation found was determined to be Reed Canary Grass (*Phalaris arundinacea*) Common Cattails (*Typha latifolia*) and Common Reed (*Phragmites australis*). During our investigation, positive wetland hydrology was met with the primary indicators of Saturation (A3) and secondary indicators of Drainage Patterns (B10). Mapped soil is identified as Elpaso silty clay loam (356A) which is a poorly drained hydric soil. Primary soil indicators of thick dark surface (A12) and Redox Dark Surface (F6) was noted within the flagged boundary.

Said vegetation soils and hydrology information noted above can be found in the datasheets section of this report. Please note data sheets 1A-4A reference wetland A.

Study Information

Site: Lizzie's Garden
 Locale: Wetland A
 By: Robert Vanni

Conservatism-Based Metrics

Mean C (native species)	2.44
Mean C (all species)	1.57
Mean C (native trees)	n/a
Mean C (native shrubs)	1.50
Mean C (native herbaceous)	2.71
FQAI (native species)	7.33
FQAI (all species)	5.88
Adjusted FQAI	19.60
% C value 0	0.36
% C Value 1-3	0.43
% C value 4-6	0.21
% C value 7-10	0.00

Additional Metrics

Species Richness (all)	14.00
Species Richness (native)	9.00
% Non-native	0.36
Wet Indicator (all)	-0.57
Wet Indicator (native)	-0.89
% hydrophyte (Midwest)	0.79
% native perennial	0.57
% native annual	0.07
% annual	0.07
% perennial	0.86

Species Acronym	Species Name (NWPL/Mohlenbrock)	Common Name	C Value	Midwest WET indicator	WET indicator (numeric)	Habit	Duration	Nativity
bidfro	<i>Bidens frondosa</i>	Devil's-Pitchfork	1	FACW	-1	Forb	Annual	Native
curarv	<i>Cirsium arvense</i>	Canadian Thistle	0	FACU	1	Forb	Perennial	Adventive
corrac	<i>Cornus racemosa</i>	Gray Dogwood	1	FAC	0	Shrub	Perennial	Native
cypstr	<i>Cyperus strigosus</i>	Straw-Color Flat Sedge	1	FACW	-1	Sedge	Perennial	Native
dipful	<i>Dipsacus fullonum</i>	Fuller's Teasel	0	FACU	1	Forb	Biennial	Adventive
epicol	<i>Eupatorium coloratum</i>	Purple-Leaf Willowherb	3	OBL	-2	Forb	Perennial	Native
helgro	<i>Helianthus grosseserratus</i>	Saw-Tooth Sunflower	4	FACW	-1	Forb	Perennial	Native
phaaru	<i>Phalaris arundinacea</i>	Reed Canary Grass	0	FACW	-1	Grass	Perennial	Adventive
phrausu	<i>Phragmites australis ssp. australis</i>	Common Reed	0	FACW	-1	Grass	Perennial	Adventive
rhatat	<i>Rhamnus cathartica</i>	European Buckthorn	0	FAC	0	Shrub	Perennial	Adventive
salint	<i>Salix interior</i>	Sandbar Willow	2	FACW	-1	Shrub	Perennial	Native
solalt	<i>Solidago altissima</i>	Tall Goldenrod	1	FACU	1	Forb	Perennial	Native
solgg	<i>Solidago gigantea</i>	Late Goldenrod	4	FACW	-1	Forb	Perennial	Native
typlat	<i>Typha latifolia</i>	Broad-Leaf Cat-Tail	5	OBL	-2	Forb	Perennial	Native

Wetland A Jurisdictional Determination Opinion: It is Midwest Ecological Inc.'s opinion that Wetland A is an isolated wetland of Will County due to a lack of a traceable connection to a Clow Creek.

Pond #1: Pond #1 is found within the central portion of the property. The pond was historically excavated in 1988 from upland soil for the purpose of clay borrow and irrigation needs of the nursery. According to the owner, the pond was excavated to a depth of 28'. The pond has a defined shoreline and was regularly maintained. A stormwater inlet was observed on the SW corner of the pond but an outfall was not identified. The historical mapped soil, based on the 1981 soil manuscript, is Saybrook silt loam (145B) which is a moderately well drained soil. The current soil manuscript notes the area as Water "W". Pond #1 was determined to be **0.81 acres** in size.

Pond #1 Jurisdictional Determination Opinion: It is MEI's opinion that the pond #1 is excavated from upland soil for the purpose of clay borrow and irrigation purpose and should be exempt from federal wetland regulations.

CONCLUSIONS

The site was evaluated using U.S. Army Corps of Engineers and USDA guidelines for identifying wetlands. After evaluation of all data obtained, the study area contains three

environmental resources: one (1) Waters of the United States (Clow Creek), one (1) open water pond and one (1) wetland totaling **1.4 acres** in size.

FEDERAL REGULATIONS

Jurisdictional Waters of the United States will be regulated under Section 404 of the Clean Water Act and the Section 401 Water Quality Certification requirements. Under Section 404, the United States Army Corps of Engineers regulates the discharge of dredged or fill material into jurisdictional Waters of the United States (WOUS).

Letter of No-Objection (LONO): The project may require a letter of No-Objection (LONO) from the Chicago District Army Corps of Engineers to facilitate development. If the proposed project avoids impact to the jurisdictional WOUS/Wetland areas then a LONO can be petitioned.

Regional Permit 1 (RP1) authorizes the construction of residential, commercial and institutional developments and associated infrastructure, such as roads, utilities, detention areas, and recreation areas. Authorization under RP1 is subject to the following requirements which shall be addressed in writing and submitted with the notification:

- a. The impact to waters of the U.S. shall not exceed 1.0 acre. For projects that impact over 0.10 acres of waters of the U.S., the permittee is required to provide compensatory mitigation.
- b. Projects that impact no more than 0.5 acres of waters of the U.S., and do not impact any high-quality aquatic resources, will be processed under Category I.
- c. Projects that impact over 0.5 acres up to 1.0 acre of waters of the U.S., or impacts high-quality aquatic resources, will be processed under Category II.

The permittee shall establish and/or enhance an upland buffer of native plants (or other appropriate vegetation approved by the District) adjacent to all created, restored, enhanced or preserved waters of the U.S., including wetlands. Created buffers should be established on 6:1 (horizontal: vertical) or gentler slopes. The following buffer widths are required:

- 1) For any waters of the U.S. determined to be a high-quality aquatic resource, the buffer shall be a minimum of 100 feet.
- 2) For any waters of the U.S. that do not qualify as wetland (e.g. lakes, rivers, ponds, etc.), the buffer shall be a minimum of 50 feet from the Ordinary High Water Mark (OHWM).
- 3) For any jurisdictional wetland from 0.25 acres up to 0.50 acres in size, the buffer shall be a minimum of 30 feet.
- 4) For any jurisdictional wetland over 0.50 acres in size, the buffer shall be a minimum of 50 feet.

The District may allow buffer widths below the above-required minimums on a case by case basis. However, it is the responsibility of the applicant to provide supporting documentation as to why the buffer requirement could not be met. Stormwater retention/detention facilities and

nature trails may be located within the outer 50% of the buffer. The District may allow Best Management Practices, small boat launches and piers/docks to be located in buffers.

Activities to be covered under the Regional Permit Program (RPP) will fall under one of two categories:

Category I: Activities with minimal impacts requiring review by the District. Authorization may include special conditions to ensure compliance with the RPP. The District has the discretion to process a Category I activity under Category II when it has concerns for aquatic resources under the Section 404(b)(1) Guidelines or for any factor of the public interest.

Category II: Activities with minimal impacts requiring more rigorous review by the District and coordination with resource agencies. Authorization may include special conditions to ensure compliance with the RPP.

Activities that do not fall into one of the above categories, by definition, have more than minimal impacts and are therefore subject to the Individual Permit review process.

EXEMPTIONS

The Army Corps of Engineers: Part 230 – Section 404 (b) (1) guidelines for specification of disposal sites for dredged or fill material.

(2) The following are not “waters of the United States”, even where they otherwise meet the terms of paragraphs (1) (iv) through (viii) of this section.

- Wet areas that are not tributaries or open waters and do not meet the agencies' regulatory definition of "wetlands"
- Waters excluded from coverage under the CWA by existing regulations
- Waters that lack a "significant nexus" where one is required for a water to be protected by the CWA
- Artificially irrigated areas that would revert to upland should irrigation cease
- **Artificial lakes or ponds created by excavating and/or diking dry land and used exclusively for such purposes as stock watering, irrigation, settling basins, or rice growing**
- Artificial reflecting pools or swimming pools created by excavating and/or diking dry land
- Small ornamental waters created by excavating and/or diking dry land for primarily aesthetic reasons
- Water-filled depressions created incidental to construction activity
- Groundwater drained through subsurface drainage systems and
- Erosional features (gullies and rills), and swales and ditches that are not tributaries or wetlands

Should you have any questions, please do not hesitate to contact our office.

Sincerely,

Midwest Ecological, Inc. (MEI)



Robert L. Vanni
Senior Environmental Review Specialist

APPENDIX A

Exhibits

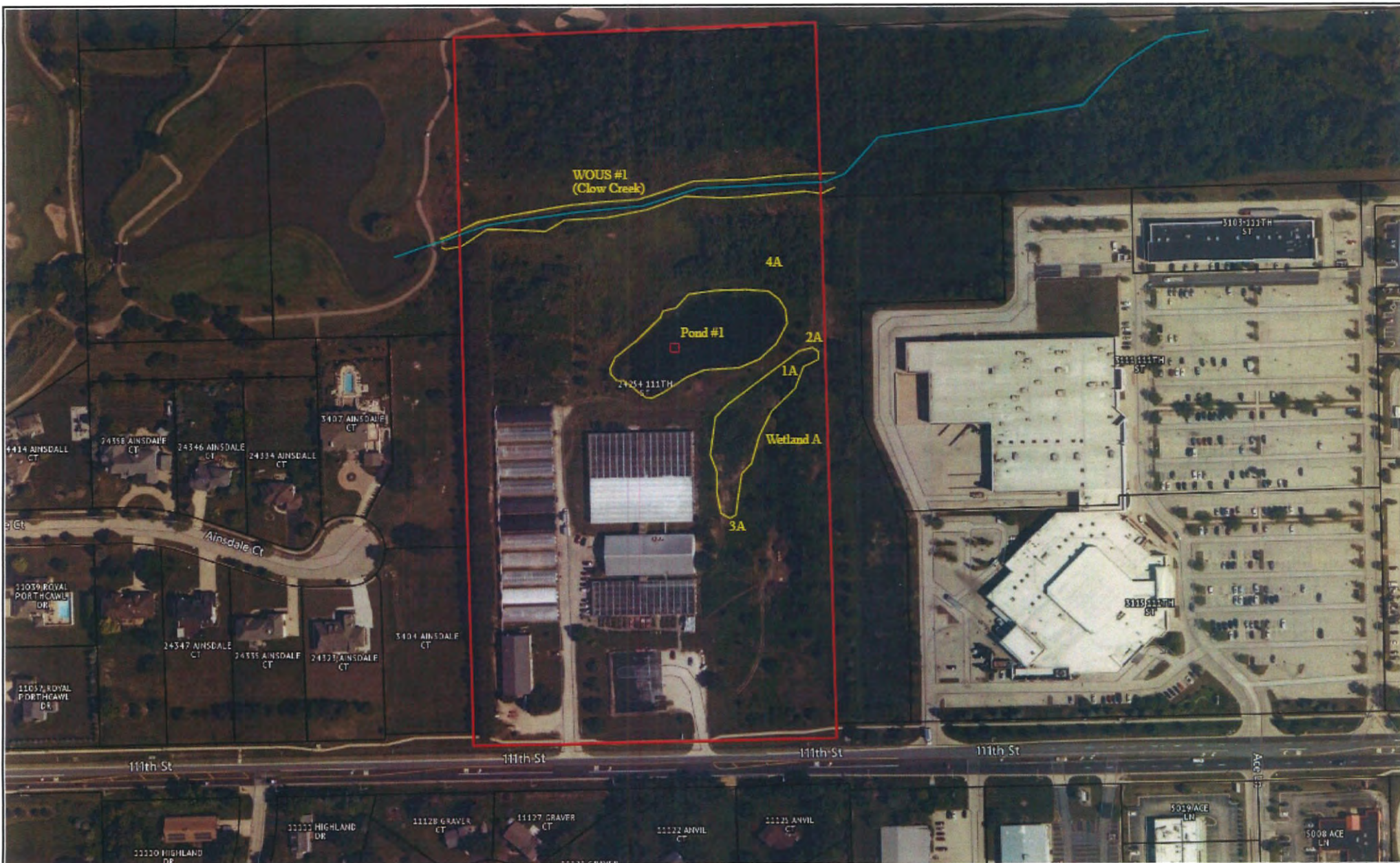

Source: 2020 Bing Aerial Mapping



Wetland Aerial Map

Client: Mr. Andrew Mouw, Lennar Corporation
 1141 East Main Street, Suite 108
 East Dundee, Illinois 60118





LEGEND:

- BOUNDARY LINE
- WETLANDS
- x WETLAND FLAGS DELINEATED BY MIDWEST ECOLOGICAL INC.

NOTES:

1. ACCORDING TO OUR INTERPOLATION OF THE FLOOD INSURANCE RATE MAPS THAT COVER THE AREA, A PORTION OF THE HEREON DESCRIBED PROPERTY FALLS WITHIN ZONE "AE", WITH A 0.2% ANNUAL CHANCE FLOOD HAZARD. AREAS OF 1% ANNUAL CHANCE FLOOD WITH AVERAGE DEPTH LESS THAN ONE FOOT OR WITH DRAINAGE AREAS OF LESS THAN ONE SQUARE MILE AS IDENTIFIED BY THE FLOOD INSURANCE RATE MAP, COMMUNITY PANEL NUMBER 17197C0037G, WITH AN EFFECTIVE DATE OF FEBRUARY 15, 2019, SUBJECT TO MAP INTERPRETATION AND SCALING.
2. EXHIBIT IS BASED ON FIELD WORK COMPLETED ON 10/16/20.

Mackie Consultants, LLC
 9575 W. Higgins Road Suite 500
 Rosemont, IL 60018
 (847) 595-1420
 www.mackieconsult.com

DESIGNED	LZ	
DRAWN	LZ	
APPROVED	RNM	
DATE	10/21/2020	
SCALE	1" = 50'	
DATE	DESCRIPTION OF REVISION	BY

**WETLAND EXHIBIT
 LIZZIE'S GARDEN
 NAPERVILLE, ILLINOIS**



Source: NETR Online Historical Aerial Images 1974



Historical Aerial Map

Client: Mr. Andrew Mouw, Lennar Corporation
1141 East Main Street, Suite 108
East Dundee, Illinois 60118





Source: NETR Online Historical Aerial Images 1988



Historical Aerial Map

Client: Mr. Andrew Mouw, Lennar Corporation
1141 East Main Street, Suite 108
East Dundee, Illinois 60118



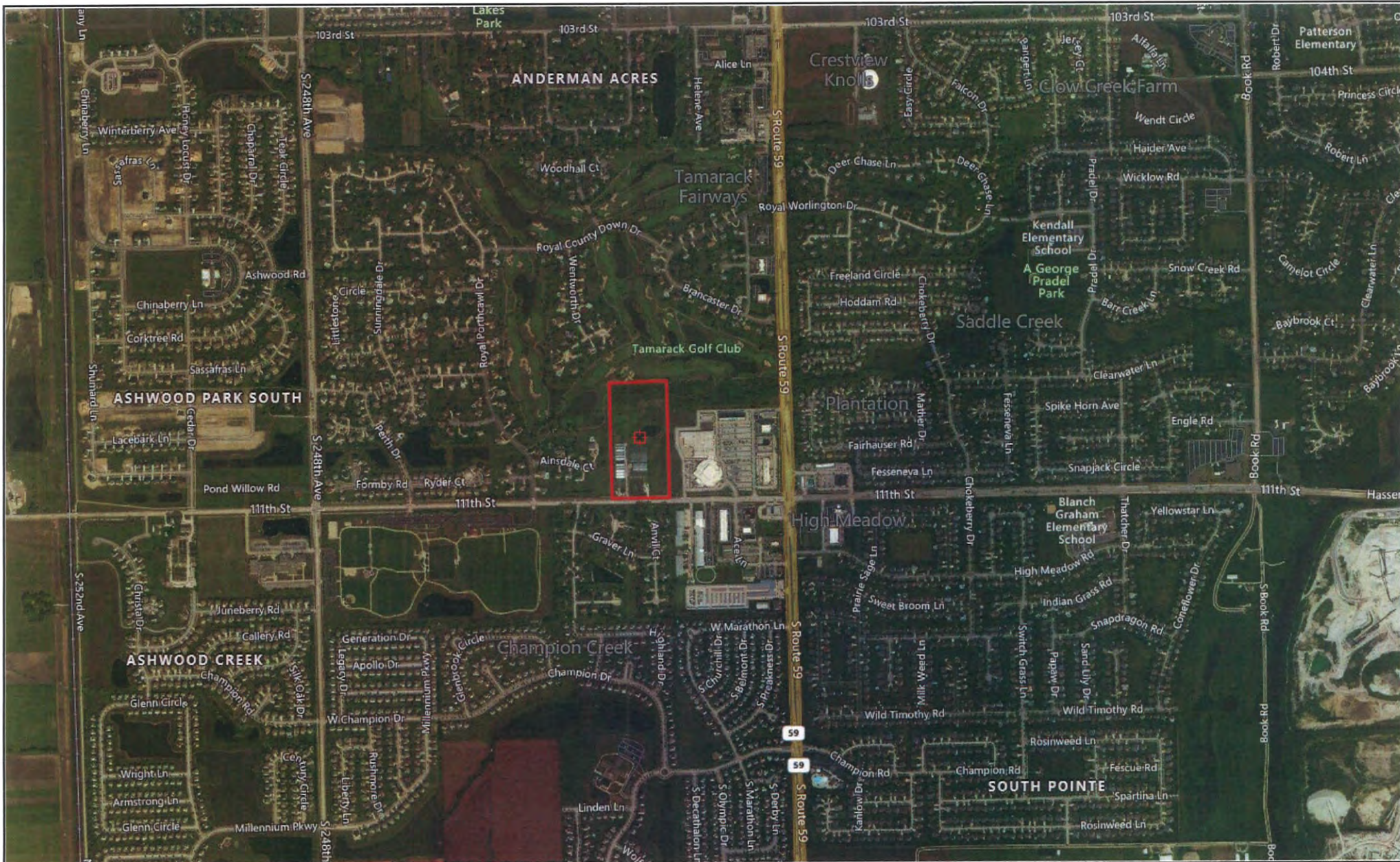

Source: Bing Street Finder Map



Location Map

Client: Mr. Andrew Mouw, Lennar Corporation
 1141 East Main Street, Suite 108
 East Dundee, Illinois 60118

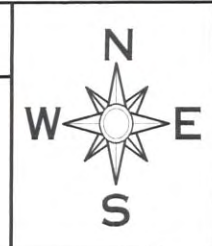

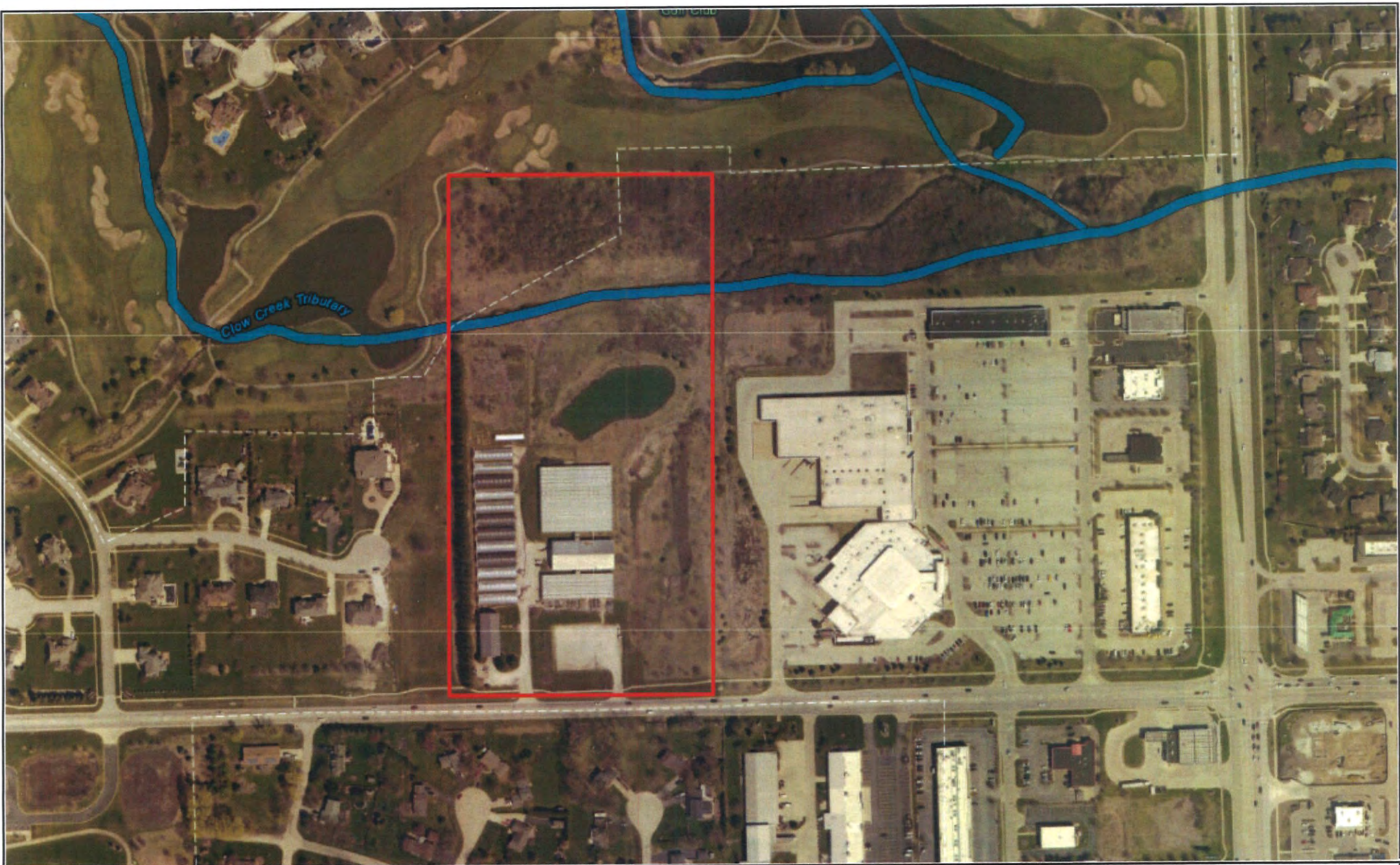

Source: National Wetland Inventory Map



NWI Map

Client: Mr. Andrew Mouw, Lennar Corporation
1141 East Main Street, Suite 108
East Dundee, Illinois 60118



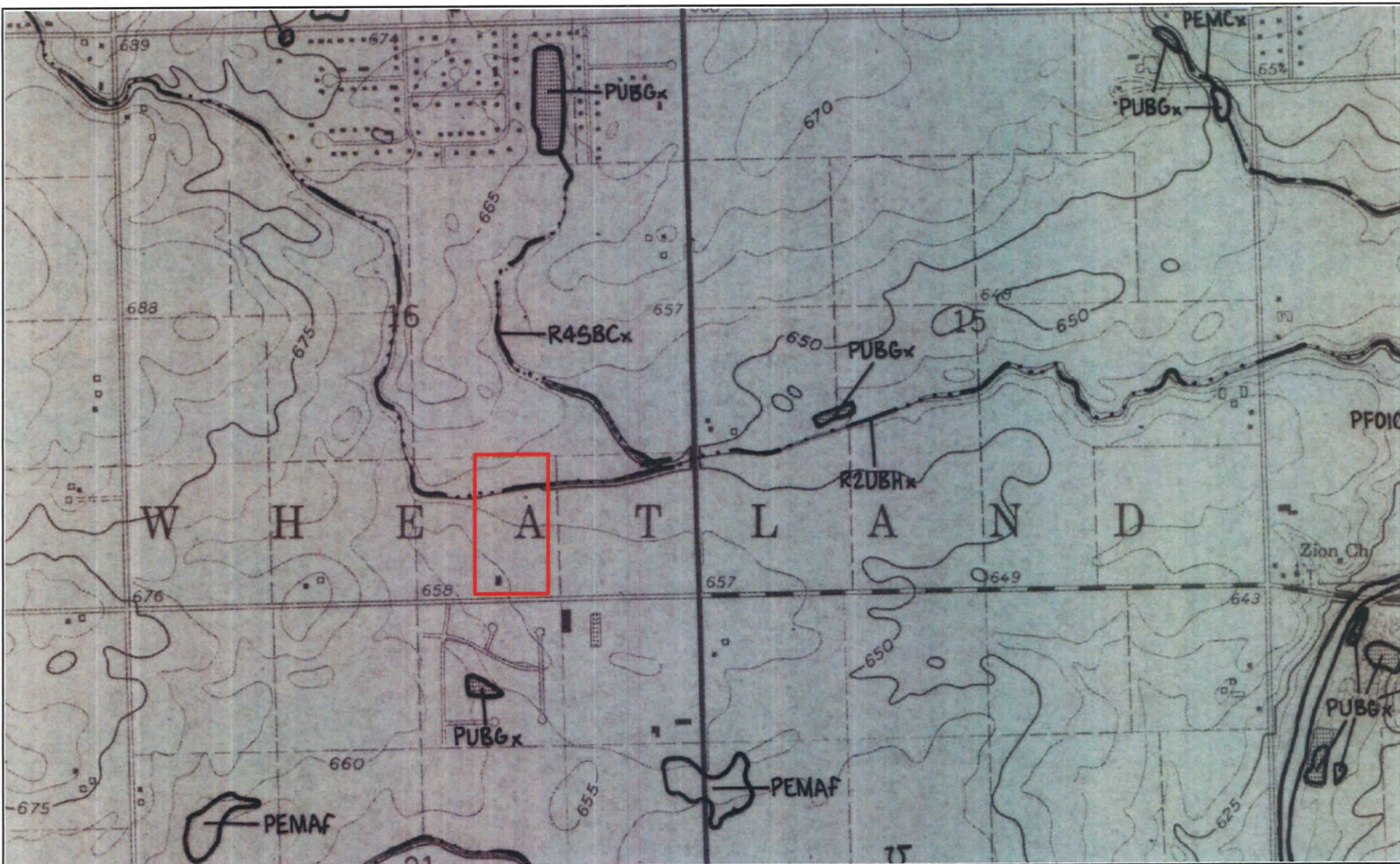

Source: National Wetland Inventory Map



NWI Map

Client: Mr. Andrew Mouw, Lennar Corporation
 1141 East Main Street, Suite 108
 East Dundee, Illinois 60118

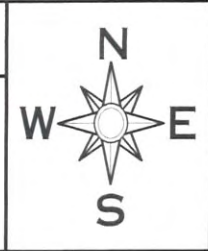

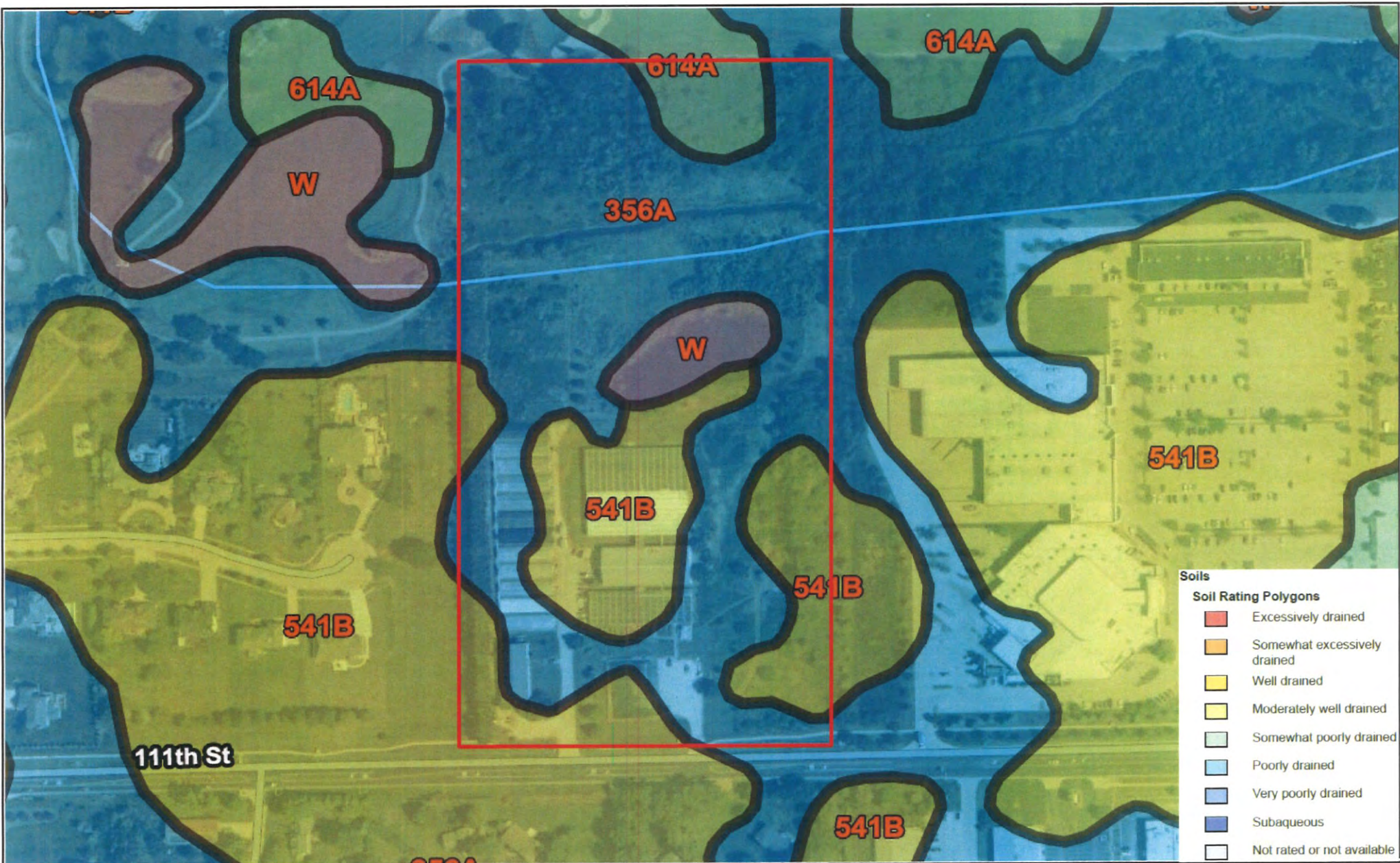

Source: Soil Survey Map of Will County (Websoil GIS)



Soils Map

Client: Mr. Andrew Mouw, Lennar Corporation
 1141 East Main Street, Suite 108
 East Dundee, Illinois 60118



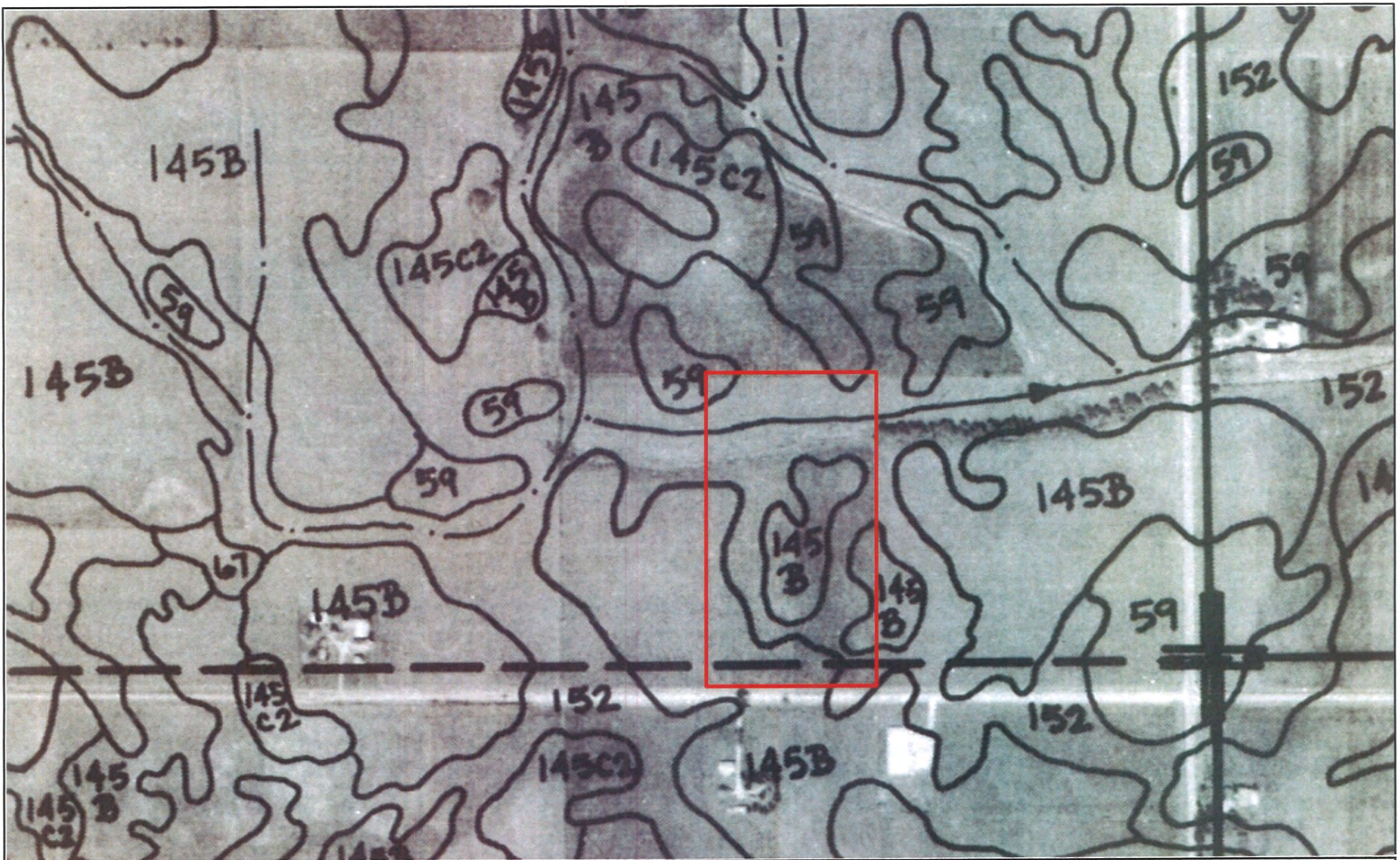

Source: Historical Soil Manuscript (2-10-1981)



Historical Soil Map

Client: Mr. Andrew Mouw, Lennar Corporation
1141 East Main Street, Suite 108
East Dundee, Illinois 60118



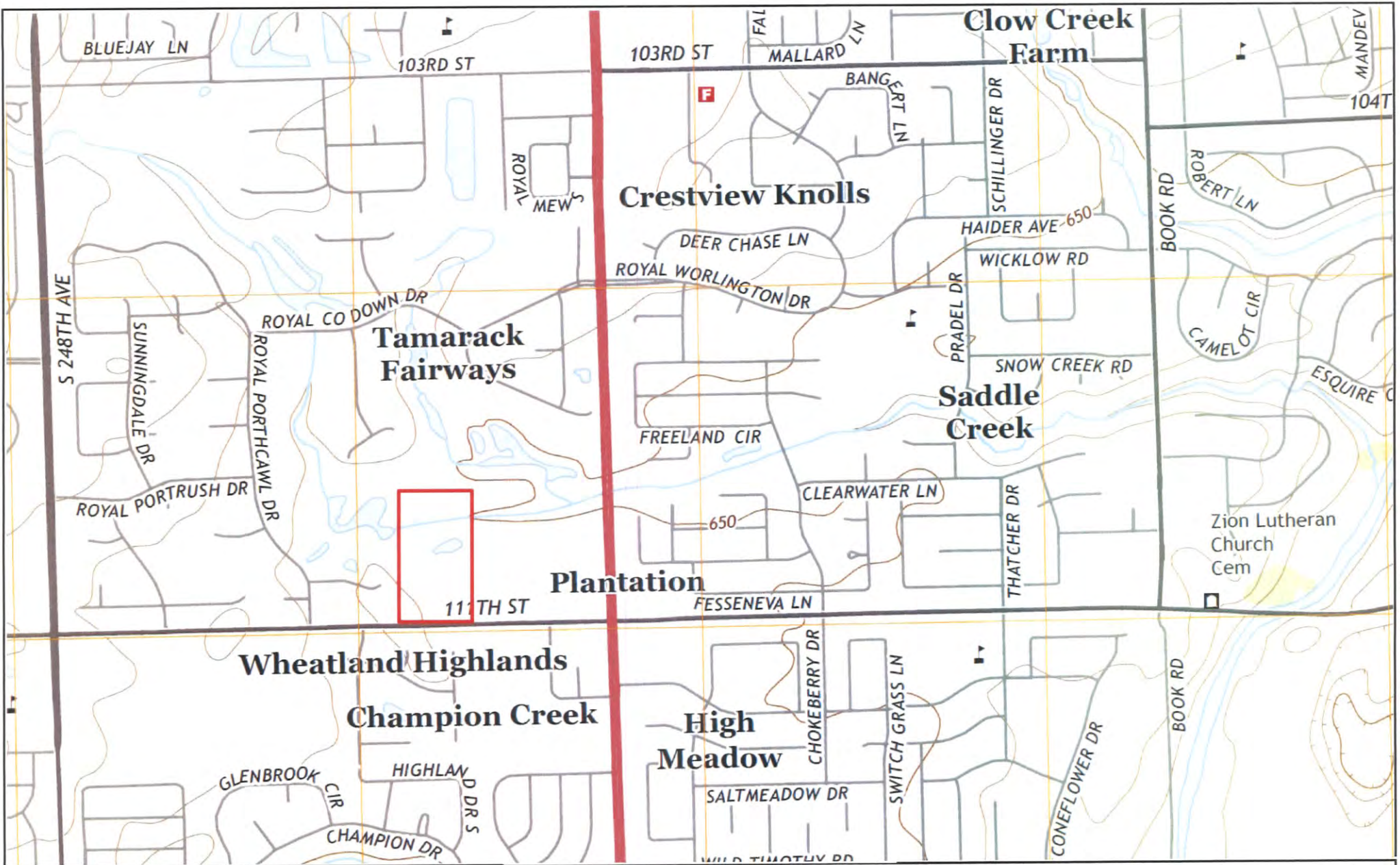

Source: United States Geological Survey Map (2015)



U.S.G.S. Map

Client: Mr. Andrew Mouw, Lennar Corporation
 1141 East Main Street, Suite 108
 East Dundee, Illinois 60118



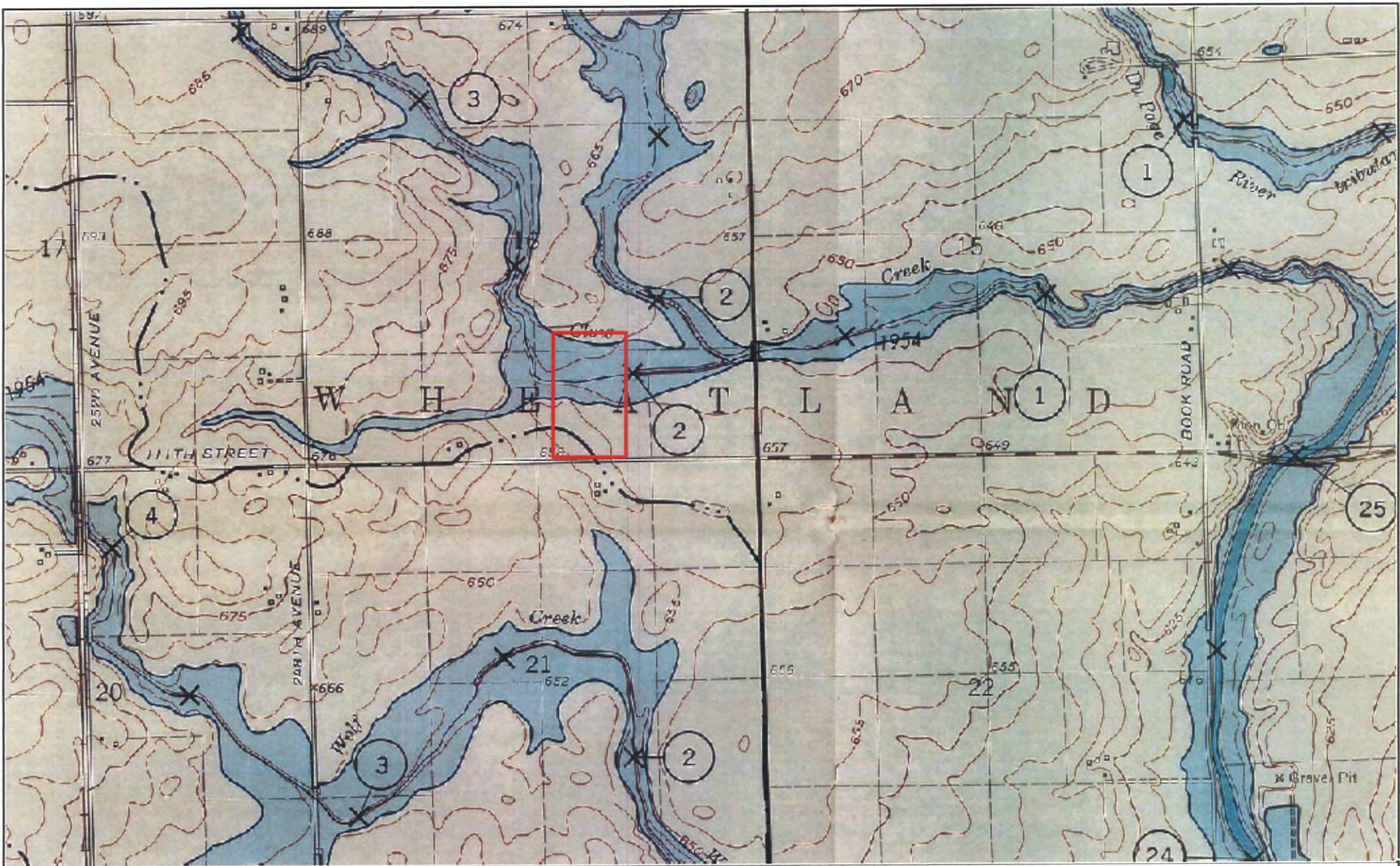

Source: United States Geological Survey Map, Hydrological Atlas, HA -210 (1966)



Hydrological Atlas Map

Client: Mr. Andrew Mouw, Lennar Corporation
 1141 East Main Street, Suite 108
 East Dundee, Illinois 60118



APPENDIX B

Photographs



Wetland A is a small emergent wetland found within a contained depression.



Surface water is conveyed from upland areas surrounding the delineated boundary. A stormwater sewer outfall, from the nursery buildings, was noted within the delineated area.



Data point 1A confirms a wetland soil condition.



Data point 2A confirms an upland soil condition.



Pond 1 is an excavated irrigation pond constructed and used for the Lizzie's Garden operation.



Clow Creek is a channelized Waters of the United States that conveys surface flow from west to east.



Clow Creek is directly connected to the DuPage River.



A concrete weir and box culvert was observed within Clow Creek on the West property line.

APPENDIX C

Data Sheets

WETLAND DETERMINATION DATA FORM – Midwest Region

Project/Site: Lizzie's Garden City/County: Naperville, Will County Sampling Date: 10-8-2020
 Applicant/Owner: Lennar Homes State: Illinois Sampling Point: 1A
 Investigator(s): Rob Vanni Section, Township, Range: Sec 26, T37 N, R 10E
 Landform (hillslope, terrace, etc.): Base of the swale Local relief (concave, convex, none): swale bottom
 Slope (%): 0-2 Lat: 41.682556 Long: -88.209907 Datum: _____
 Soil Map Unit Name: Elpaso silty clay loam (232 A) NWI or WWI classification: Yes
 Are climatic / hydrologic conditions on the site typical for this time of year? Yes No _____ (If no, explain in Remarks.)
 Are Vegetation _____, Soil _____, or Hydrology _____ significantly disturbed? Are "Normal Circumstances" present? Yes No _____
 Are Vegetation _____, Soil _____, or Hydrology _____ naturally problematic? (If needed, explain any answers in Remarks.)

SUMMARY OF FINDINGS – Attach site map showing sampling point locations, transects, important features, etc.

Hydrophytic Vegetation Present? Yes <input checked="" type="checkbox"/> No _____ Hydric Soil Present? Yes <input checked="" type="checkbox"/> No _____ Wetland Hydrology Present? Yes <input checked="" type="checkbox"/> No _____	Is the Sampled Area within a Wetland? Yes <input checked="" type="checkbox"/> No _____
Remarks: _____	

VEGETATION – Use scientific names of plants.

Tree Stratum (Plot size: _____)	Absolute % Cover	Dominant Species?	Indicator Status	Dominance Test worksheet:														
1. _____	_____	_____	_____	Number of Dominant Species That Are OBL, FACW, or FAC: <u>1</u> (A)														
2. _____	_____	_____	_____	Total Number of Dominant Species Across All Strata: <u>1</u> (B)														
3. _____	_____	_____	_____	Percent of Dominant Species That Are OBL, FACW, or FAC: <u>100</u> (A/B)														
4. _____	_____	_____	_____															
5. _____	_____	_____	_____															
_____ = Total Cover																		
Sapling/Shrub Stratum (Plot size: _____)																		
1. _____	_____	_____	_____	Prevalence Index worksheet: <table style="width: 100%; border-collapse: collapse;"> <tr> <td style="width: 50%;">Total % Cover of:</td> <td style="width: 50%;">Multiply by:</td> </tr> <tr> <td>OBL species <u>30</u></td> <td>x 1 = <u>30</u></td> </tr> <tr> <td>FACW species <u>60</u></td> <td>x 2 = <u>120</u></td> </tr> <tr> <td>FAC species <u>0</u></td> <td>x 3 = <u>0</u></td> </tr> <tr> <td>FACU species <u>10</u></td> <td>x 4 = <u>40</u></td> </tr> <tr> <td>UPL species <u>0</u></td> <td>x 5 = <u>0</u></td> </tr> <tr> <td>Column Totals: <u>100</u> (A)</td> <td><u>190</u> (B)</td> </tr> </table>	Total % Cover of:	Multiply by:	OBL species <u>30</u>	x 1 = <u>30</u>	FACW species <u>60</u>	x 2 = <u>120</u>	FAC species <u>0</u>	x 3 = <u>0</u>	FACU species <u>10</u>	x 4 = <u>40</u>	UPL species <u>0</u>	x 5 = <u>0</u>	Column Totals: <u>100</u> (A)	<u>190</u> (B)
Total % Cover of:	Multiply by:																	
OBL species <u>30</u>	x 1 = <u>30</u>																	
FACW species <u>60</u>	x 2 = <u>120</u>																	
FAC species <u>0</u>	x 3 = <u>0</u>																	
FACU species <u>10</u>	x 4 = <u>40</u>																	
UPL species <u>0</u>	x 5 = <u>0</u>																	
Column Totals: <u>100</u> (A)	<u>190</u> (B)																	
2. _____	_____	_____	_____															
3. _____	_____	_____	_____															
4. _____	_____	_____	_____															
5. _____	_____	_____	_____															
_____ = Total Cover																		
Herb Stratum (Plot size: _____)																		
1. <u><i>Typha latifolia</i></u>	<u>20</u>	No	OBL	Hydrophytic Vegetation Indicators: <input checked="" type="checkbox"/> Dominance Test is >50% <input checked="" type="checkbox"/> Prevalence Index is ≤3.0 ¹ _____ Morphological Adaptations ¹ (Provide supporting data in Remarks or on a separate sheet) _____ Problematic Hydrophytic Vegetation ¹ (Explain) ¹ Indicators of hydric soil and wetland hydrology must be present, unless disturbed or problematic.														
2. <u><i>Phalaris arundinacea</i></u>	<u>60</u>	Yes	FACW															
3. <u><i>Epilobium coloratum</i></u>	<u>10</u>	No	OBL															
4. <u><i>Cirsium arvense</i></u>	<u>10</u>	No	FACU															
5. _____	_____	_____	_____															
6. _____	_____	_____	_____															
7. _____	_____	_____	_____															
8. _____	_____	_____	_____															
9. _____	_____	_____	_____															
10. _____	_____	_____	_____															
_____ = Total Cover																		
Woody Vine Stratum (Plot size: _____)																		
1. _____	_____	_____	_____	Hydrophytic Vegetation Present? Yes <input checked="" type="checkbox"/> No _____														
2. _____	_____	_____	_____															
_____ = Total Cover																		
Remarks: (Include photo numbers here or on a separate sheet.) Hydrophytic vegetation was present within the sample point.																		

SOIL

Sampling Point: 1A

Profile Description: (Describe to the depth needed to document the indicator or confirm the absence of indicators.)

Depth (inches)	Matrix		Redox Features				Texture	Remarks
	Color (moist)	%	Color (moist)	%	Type ¹	Loc ²		
0-12"	10 YR 2/1	100			C	M	SiCL	
12-18"	10 YR 2/1	85	2.5 Y 4/2	10	C	M	SiCL	
			10 YR 4/4	5				

¹Type: C=Concentration, D=Depletion, RM=Reduced Matrix, CS=Covered or Coated Sand Grains. ²Location: PL=Pore Lining, M=Matrix.

Hydric Soil Indicators:

- Histosol (A1)
- Histic Epipedon (A2)
- Black Histic (A3)
- Hydrogen Sulfide (A4)
- Stratified Layers (A5)
- 2 cm Muck (A10)
- Depleted Below Dark Surface (A11)
- Thick Dark Surface (A12)
- Sandy Mucky Mineral (S1)
- 5 cm Mucky Peat or Peat (S3)

- Sandy Gleyed Matrix (S4)
- Sandy Redox (S5)
- Stripped Matrix (S6)
- Loamy Mucky Mineral (F1)
- Loamy Gleyed Matrix (F2)
- Depleted Matrix (F3)
- Redox Dark Surface (F6)
- Depleted Dark Surface (F7)
- Redox Depressions (F8)

Indicators for Problematic Hydric Soils³:

- Coast Prairie Redox (A16)
- Iron-Manganese Masses (F12)
- Other (Explain in Remarks)

³Indicators of hydrophytic vegetation and wetland hydrology must be present, unless disturbed or problematic.

Restrictive Layer (if observed):

Type: _____
Depth (inches): _____

Hydric Soil Present? Yes No

Remarks:

Hydric soil was noted within the sample point.

HYDROLOGY

Wetland Hydrology Indicators:

Primary Indicators (minimum of one is required; check all that apply)

- Surface Water (A1)
- High Water Table (A2)
- Saturation (A3)
- Water Marks (B1)
- Sediment Deposits (B2)
- Drift Deposits (B3)
- Algal Mat or Crust (B4)
- Iron Deposits (B5)
- Inundation Visible on Aerial Imagery (B7)
- Sparsely Vegetated Concave Surface (B8)

- Water-Stained Leaves (B9)
- Aquatic Fauna (B13)
- True Aquatic Plants (B14)
- Hydrogen Sulfide Odor (C1)
- Oxidized Rhizospheres on Living Roots (C3)
- Presence of Reduced Iron (C4)
- Recent Iron Reduction in Tilled Soils (C6)
- Thin Muck Surface (C7)
- Gauge or Well Data (D9)
- Other (Explain in Remarks)

Secondary Indicators (minimum of two required)

- Surface Soil Cracks (B6)
- Drainage Patterns (B10)
- Dry-Season Water Table (C2)
- Crayfish Burrows (C8)
- Saturation Visible on Aerial Imagery (C9)
- Stunted or Stressed Plants (D1)
- Geomorphic Position (D2)
- FAC-Neutral Test (D5)

Field Observations:

Surface Water Present? Yes No Depth (inches): _____
 Water Table Present? Yes No Depth (inches): _____
 Saturation Present? (includes capillary fringe) Yes No Depth (inches): 10"

Wetland Hydrology Present? Yes No

Describe Recorded Data (stream gauge, monitoring well, aerial photos, previous inspections), if available:

Remarks:

Wetland hydrology criteria has been met.

WETLAND DETERMINATION DATA FORM – Midwest Region

Project/Site: Lizzie's Garden City/County: Naperville, Will County Sampling Date: 10-8-2020

Applicant/Owner: Lennar Homes State: Illinois Sampling Point: 2A

Investigator(s): Rob Vanni Section, Township, Range: Sec 26, T37 N, R 10E

Landform (hillslope, terrace, etc.): _____ Local relief (concave, convex, none): _____

Slope (%): 0-2 Lat: 41.682715 Long: -88.209698 Datum: _____

Soil Map Unit Name: Elpaso silty clay loam (232 A) NWI or WWI classification: Yes

Are climatic / hydrologic conditions on the site typical for this time of year? Yes No _____ (If no, explain in Remarks.)

Are Vegetation _____, Soil _____, or Hydrology _____ significantly disturbed? Are "Normal Circumstances" present? Yes No _____

Are Vegetation _____, Soil _____, or Hydrology _____ naturally problematic? (If needed, explain any answers in Remarks.)

SUMMARY OF FINDINGS – Attach site map showing sampling point locations, transects, important features, etc.

Hydrophytic Vegetation Present?	Yes _____	No <input checked="" type="checkbox"/>	Is the Sampled Area within a Wetland?	Yes _____	No <input checked="" type="checkbox"/>
Hydric Soil Present?	Yes _____	No <input checked="" type="checkbox"/>			
Wetland Hydrology Present?	Yes _____	No <input checked="" type="checkbox"/>			
Remarks:					

VEGETATION – Use scientific names of plants.

Tree Stratum (Plot size: _____)	Absolute % Cover	Dominant Species?	Indicator Status	Dominance Test worksheet:																					
1. _____	_____	_____	_____	Number of Dominant Species That Are OBL, FACW, or FAC: <u>1</u> (A) Total Number of Dominant Species Across All Strata: <u>3</u> (B) Percent of Dominant Species That Are OBL, FACW, or FAC: <u>33</u> (A/B)																					
2. _____	_____	_____	_____																						
3. _____	_____	_____	_____																						
4. _____	_____	_____	_____																						
5. _____	_____	_____	_____																						
_____ = Total Cover				Prevalence Index worksheet: <table style="width: 100%; border-collapse: collapse;"> <tr> <td style="width: 30%;"></td> <td style="width: 30%; text-align: center;">Total % Cover of:</td> <td style="width: 30%; text-align: center;">Multiply by:</td> </tr> <tr> <td>OBL species</td> <td style="text-align: center;">30</td> <td style="text-align: center;">x 1 = 30</td> </tr> <tr> <td>FACW species</td> <td style="text-align: center;">60</td> <td style="text-align: center;">x 2 = 120</td> </tr> <tr> <td>FAC species</td> <td style="text-align: center;">0</td> <td style="text-align: center;">x 3 = 0</td> </tr> <tr> <td>FACU species</td> <td style="text-align: center;">10</td> <td style="text-align: center;">x 4 = 40</td> </tr> <tr> <td>UPL species</td> <td style="text-align: center;">0</td> <td style="text-align: center;">x 5 = 0</td> </tr> <tr> <td>Column Totals:</td> <td style="text-align: center;">100 (A)</td> <td style="text-align: center;">190 (B)</td> </tr> </table> Prevalence Index = B/A = <u>1.90</u>		Total % Cover of:	Multiply by:	OBL species	30	x 1 = 30	FACW species	60	x 2 = 120	FAC species	0	x 3 = 0	FACU species	10	x 4 = 40	UPL species	0	x 5 = 0	Column Totals:	100 (A)	190 (B)
	Total % Cover of:	Multiply by:																							
OBL species	30	x 1 = 30																							
FACW species	60	x 2 = 120																							
FAC species	0	x 3 = 0																							
FACU species	10	x 4 = 40																							
UPL species	0	x 5 = 0																							
Column Totals:	100 (A)	190 (B)																							
Sapling/Shrub Stratum (Plot size: _____) 1. _____ 2. _____ 3. _____ 4. _____ 5. _____ _____ = Total Cover																									
Herb Stratum (Plot size: _____) 1. <i>Cirsium arvense</i> 30 Yes FACU 2. <i>Phalaris arundinacea</i> 45 Yes FACW 3. <i>Dipsacus fullonum</i> 25 Yes FACU 4. _____ 5. _____ 6. _____ 7. _____ 8. _____ 9. _____ 10. _____ _____ = Total Cover																									
Woody Vine Stratum (Plot size: _____) 1. _____ 2. _____ _____ = Total Cover																									
Remarks: (Include photo numbers here or on a separate sheet.) Hydrophytic vegetation was not present within the sample point.				Hydrophytic Vegetation Present? Yes _____ No <input checked="" type="checkbox"/>																					

SOIL

Sampling Point: 2A

Profile Description: (Describe to the depth needed to document the indicator or confirm the absence of indicators.)

Depth (inches)	Matrix		Redox Features				Texture	Remarks
	Color (moist)	%	Color (moist)	%	Type ¹	Loc ²		
0-8"	10 YR 2/1	100			C	M	SiCL	
8-16"	10 YR 3/2	90	10 YR 5/4	10	C	M	SiCL	

¹Type: C=Concentration, D=Depletion, RM=Reduced Matrix, CS=Covered or Coated Sand Grains. ²Location: PL=Pore Lining, M=Matrix.

Hydric Soil Indicators:

- Histosol (A1)
- Histic Epipedon (A2)
- Black Histic (A3)
- Hydrogen Sulfide (A4)
- Stratified Layers (A5)
- 2 cm Muck (A10)
- Depleted Below Dark Surface (A11)
- Thick Dark Surface (A12)
- Sandy Mucky Mineral (S1)
- 5 cm Mucky Peat or Peat (S3)

- Sandy Gleyed Matrix (S4)
- Sandy Redox (S5)
- Stripped Matrix (S6)
- Loamy Mucky Mineral (F1)
- Loamy Gleyed Matrix (F2)
- Depleted Matrix (F3)
- Redox Dark Surface (F6)
- Depleted Dark Surface (F7)
- Redox Depressions (F8)

Indicators for Problematic Hydric Soils³:

- Coast Prairie Redox (A16)
- Iron-Manganese Masses (F12)
- Other (Explain in Remarks)

³Indicators of hydrophytic vegetation and wetland hydrology must be present, unless disturbed or problematic.

Restrictive Layer (if observed):

Type: _____
 Depth (inches): _____

Hydric Soil Present? Yes _____ No X

Remarks:

Hydric soil was not noted within the sample point.

HYDROLOGY

Wetland Hydrology Indicators:

Primary Indicators (minimum of one is required; check all that apply)

- Surface Water (A1)
- High Water Table (A2)
- Saturation (A3)
- Water Marks (B1)
- Sediment Deposits (B2)
- Drift Deposits (B3)
- Algal Mat or Crust (B4)
- Iron Deposits (B5)
- Inundation Visible on Aerial Imagery (B7)
- Sparsely Vegetated Concave Surface (B8)

- Water-Stained Leaves (B9)
- Aquatic Fauna (B13)
- True Aquatic Plants (B14)
- Hydrogen Sulfide Odor (C1)
- Oxidized Rhizospheres on Living Roots (C3)
- Presence of Reduced Iron (C4)
- Recent Iron Reduction in Tilled Soils (C6)
- Thin Muck Surface (C7)
- Gauge or Well Data (D9)
- Other (Explain in Remarks)

Secondary Indicators (minimum of two required)

- Surface Soil Cracks (B6)
- Drainage Patterns (B10)
- Dry-Season Water Table (C2)
- Crayfish Burrows (C8)
- Saturation Visible on Aerial Imagery (C9)
- Stunted or Stressed Plants (D1)
- Geomorphic Position (D2)
- FAC-Neutral Test (D5)

Field Observations:

Surface Water Present? Yes _____ No X Depth (inches): _____
 Water Table Present? Yes _____ No X Depth (inches): _____
 Saturation Present? (includes capillary fringe) Yes _____ No X Depth (inches): >16"

Wetland Hydrology Present? Yes _____ No X

Describe Recorded Data (stream gauge, monitoring well, aerial photos, previous inspections), if available:

Remarks:

Wetland hydrology criteria was not met.

WETLAND DETERMINATION DATA FORM – Midwest Region

Project/Site: Lizzie's Garden City/County: Naperville, Will County Sampling Date: 10-8-2020
 Applicant/Owner: Lennar Homes State: Illinois Sampling Point: 3A
 Investigator(s): Rob Vanni Section, Township, Range: Sec 26, T37 N, R 10E
 Landform (hillslope, terrace, etc.): _____ Local relief (concave, convex, none): _____
 Slope (%): 0-2 Lat: 41.681852 Long: -88.210319 Datum: _____
 Soil Map Unit Name: Elpaso silty clay loam (232 A) NWI or WWI classification: Yes
 Are climatic / hydrologic conditions on the site typical for this time of year? Yes No _____ (If no, explain in Remarks.)
 Are Vegetation _____, Soil _____, or Hydrology _____ significantly disturbed? Are "Normal Circumstances" present? Yes No _____
 Are Vegetation _____, Soil _____, or Hydrology _____ naturally problematic? (If needed, explain any answers in Remarks.)

SUMMARY OF FINDINGS – Attach site map showing sampling point locations, transects, important features, etc.

Hydrophytic Vegetation Present?	Yes _____	No <input checked="" type="checkbox"/>	Is the Sampled Area within a Wetland?	Yes _____	No <input checked="" type="checkbox"/>
Hydric Soil Present?	Yes _____	No <input checked="" type="checkbox"/>			
Wetland Hydrology Present?	Yes _____	No <input checked="" type="checkbox"/>			
Remarks:					

VEGETATION – Use scientific names of plants.

Tree Stratum (Plot size: _____)	Absolute % Cover	Dominant Species?	Indicator Status	Dominance Test worksheet:
1. _____	_____	_____	_____	Number of Dominant Species That Are OBL, FACW, or FAC: <u>0</u> (A)
2. _____	_____	_____	_____	Total Number of Dominant Species Across All Strata: <u>2</u> (B)
3. _____	_____	_____	_____	Percent of Dominant Species That Are OBL, FACW, or FAC: <u>0</u> (A/B)
4. _____	_____	_____	_____	
5. _____	_____	_____	_____	
_____ = Total Cover				
Sapling/Shrub Stratum (Plot size: _____)				
1. _____	_____	_____	_____	Prevalence Index worksheet:
2. _____	_____	_____	_____	Total % Cover of: _____ Multiply by: _____
3. _____	_____	_____	_____	OBL species <u>0</u> x 1 = <u>0</u>
4. _____	_____	_____	_____	FACW species <u>20</u> x 2 = <u>40</u>
5. _____	_____	_____	_____	FAC species <u>0</u> x 3 = <u>0</u>
_____ = Total Cover				FACU species <u>80</u> x 4 = <u>320</u>
				UPL species <u>0</u> x 5 = <u>0</u>
				Column Totals: <u>100</u> (A) <u>360</u> (B)
				Prevalence Index = B/A = <u>3.60</u>
Herb Stratum (Plot size: _____)				
1. <i>Cirsium arvense</i>	20	No	FACU	Hydrophytic Vegetation Indicators: ___ Dominance Test is >50% ___ Prevalence Index is ≤3.0 ¹ ___ Morphological Adaptations ¹ (Provide supporting data in Remarks or on a separate sheet) ___ Problematic Hydrophytic Vegetation ¹ (Explain) ¹ Indicators of hydric soil and wetland hydrology must be present, unless disturbed or problematic.
2. <i>Phalaris arundinacea</i>	20	No	FACW	
3. <i>Dipsacus fullonum</i>	30	Yes	FACU	
4. <i>Solidago altissima</i>	30	Yes	FACU	
5. _____	_____	_____	_____	
6. _____	_____	_____	_____	
7. _____	_____	_____	_____	
8. _____	_____	_____	_____	
9. _____	_____	_____	_____	
10. _____	_____	_____	_____	
100 = Total Cover				
Woody Vine Stratum (Plot size: _____)				
1. _____	_____	_____	_____	Hydrophytic Vegetation Present?
2. _____	_____	_____	_____	
_____ = Total Cover				
Remarks: (Include photo numbers here or on a separate sheet.)				
Hydrophytic vegetation was not present within the sample point.				

SOIL

Sampling Point: 3A

Profile Description: (Describe to the depth needed to document the indicator or confirm the absence of indicators.)								
Depth (inches)	Matrix		Redox Features				Texture	Remarks
	Color (moist)	%	Color (moist)	%	Type ¹	Loc ²		
0-14"	10 YR 3/2	100			C	M	SiCL	
14-18"	10 YR 4/4	95	10 YR 5/6	5	C	M	SiCL	

¹Type: C=Concentration, D=Depletion, RM=Reduced Matrix, CS=Covered or Coated Sand Grains. ²Location: PL=Pore Lining, M=Matrix.

Hydric Soil Indicators: <input type="checkbox"/> Histosol (A1) <input type="checkbox"/> Histic Epipedon (A2) <input type="checkbox"/> Black Histic (A3) <input type="checkbox"/> Hydrogen Sulfide (A4) <input type="checkbox"/> Stratified Layers (A5) <input type="checkbox"/> 2 cm Muck (A10) <input type="checkbox"/> Depleted Below Dark Surface (A11) <input type="checkbox"/> Thick Dark Surface (A12) <input type="checkbox"/> Sandy Mucky Mineral (S1) <input type="checkbox"/> 5 cm Mucky Peat or Peat (S3)	<input type="checkbox"/> Sandy Gleyed Matrix (S4) <input type="checkbox"/> Sandy Redox (S5) <input type="checkbox"/> Stripped Matrix (S6) <input type="checkbox"/> Loamy Mucky Mineral (F1) <input type="checkbox"/> Loamy Gleyed Matrix (F2) <input type="checkbox"/> Depleted Matrix (F3) <input type="checkbox"/> Redox Dark Surface (F6) <input type="checkbox"/> Depleted Dark Surface (F7) <input type="checkbox"/> Redox Depressions (F8)	Indicators for Problematic Hydric Soils³: <input type="checkbox"/> Coast Prairie Redox (A16) <input type="checkbox"/> Iron-Manganese Masses (F12) <input type="checkbox"/> Other (Explain in Remarks)
---	--	--

³Indicators of hydrophytic vegetation and wetland hydrology must be present, unless disturbed or problematic.

Restrictive Layer (if observed): Type: _____ Depth (inches): _____	Hydric Soil Present? Yes _____ No <input checked="" type="checkbox"/>
---	---

Remarks:

Hydric soil was not noted within the sample point.

HYDROLOGY

Wetland Hydrology Indicators:		
Primary Indicators (minimum of one is required; check all that apply)	Secondary Indicators (minimum of two required)	
<input type="checkbox"/> Surface Water (A1) <input type="checkbox"/> High Water Table (A2) <input type="checkbox"/> Saturation (A3) <input type="checkbox"/> Water Marks (B1) <input type="checkbox"/> Sediment Deposits (B2) <input type="checkbox"/> Drift Deposits (B3) <input type="checkbox"/> Algal Mat or Crust (B4) <input type="checkbox"/> Iron Deposits (B5) <input type="checkbox"/> Inundation Visible on Aerial Imagery (B7) <input type="checkbox"/> Sparsely Vegetated Concave Surface (B8)	<input type="checkbox"/> Water-Stained Leaves (B9) <input type="checkbox"/> Aquatic Fauna (B13) <input type="checkbox"/> True Aquatic Plants (B14) <input type="checkbox"/> Hydrogen Sulfide Odor (C1) <input type="checkbox"/> Oxidized Rhizospheres on Living Roots (C3) <input type="checkbox"/> Presence of Reduced Iron (C4) <input type="checkbox"/> Recent Iron Reduction in Tilled Soils (C6) <input type="checkbox"/> Thin Muck Surface (C7) <input type="checkbox"/> Gauge or Well Data (D9) <input type="checkbox"/> Other (Explain in Remarks)	<input type="checkbox"/> Surface Soil Cracks (B6) <input checked="" type="checkbox"/> Drainage Patterns (B10) <input type="checkbox"/> Dry-Season Water Table (C2) <input type="checkbox"/> Crayfish Burrows (C8) <input type="checkbox"/> Saturation Visible on Aerial Imagery (C9) <input type="checkbox"/> Stunted or Stressed Plants (D1) <input type="checkbox"/> Geomorphic Position (D2) <input type="checkbox"/> FAC-Neutral Test (D5)
Field Observations: Surface Water Present? Yes _____ No <input checked="" type="checkbox"/> Depth (inches): _____ Water Table Present? Yes _____ No <input checked="" type="checkbox"/> Depth (inches): _____ Saturation Present? Yes _____ No <input checked="" type="checkbox"/> Depth (inches): _____ >18" (includes capillary fringe)		Wetland Hydrology Present? Yes _____ No <input checked="" type="checkbox"/>
Describe Recorded Data (stream gauge, monitoring well, aerial photos, previous inspections), if available:		
Remarks: Wetland hydrology criteria was not met.		

WETLAND DETERMINATION DATA FORM – Midwest Region

Project/Site: Lizzie's Garden City/County: Naperville, Will County Sampling Date: 10-8-2020

Applicant/Owner: Lennar Homes State: Illinois Sampling Point: 4A

Investigator(s): Rob Vanni Section, Township, Range: Sec 26, T37 N, R 10E

Landform (hillslope, terrace, etc.): _____ Local relief (concave, convex, none): _____

Slope (%): 0-2 Lat: 41.683130 Long: -88.209782 Datum: _____

Soil Map Unit Name: Elpaso silty clay loam (232 A) NWI or WWI classification: Yes

Are climatic / hydrologic conditions on the site typical for this time of year? Yes No _____ (If no, explain in Remarks.)

Are Vegetation _____, Soil , or Hydrology _____ significantly disturbed? Are "Normal Circumstances" present? Yes _____ No

Are Vegetation _____, Soil _____, or Hydrology _____ naturally problematic? (If needed, explain any answers in Remarks.)

SUMMARY OF FINDINGS – Attach site map showing sampling point locations, transects, important features, etc.

Hydrophytic Vegetation Present? Yes <input checked="" type="checkbox"/> No _____ Hydric Soil Present? Yes _____ No <input checked="" type="checkbox"/> Wetland Hydrology Present? Yes _____ No <input checked="" type="checkbox"/>	Is the Sampled Area within a Wetland? Yes _____ No <input checked="" type="checkbox"/>
Remarks: This area is suspected fill area due to the pond excavation. Gravel and soil piles were observed.	

VEGETATION – Use scientific names of plants.

Tree Stratum (Plot size: _____)	Absolute % Cover	Dominant Species?	Indicator Status	
1. _____	_____	_____	_____	
2. _____	_____	_____	_____	
3. _____	_____	_____	_____	
4. _____	_____	_____	_____	
5. _____	_____	_____	_____	
_____ = Total Cover				
Sapling/Shrub Stratum (Plot size: _____)				
1. _____	_____	_____	_____	
2. _____	_____	_____	_____	
3. _____	_____	_____	_____	
4. _____	_____	_____	_____	
5. _____	_____	_____	_____	
_____ = Total Cover				
Herb Stratum (Plot size: _____)				
1. <i>Cirsium arvense</i>	20	No	FACU	
2. <i>Salix interior</i>	40	Yes	OBL	
3. <i>Dipsacus fullonum</i>	40	Yes	FACU	
4. _____	_____	_____	_____	
5. _____	_____	_____	_____	
6. _____	_____	_____	_____	
7. _____	_____	_____	_____	
8. _____	_____	_____	_____	
9. _____	_____	_____	_____	
10. _____	_____	_____	_____	
100 = Total Cover				
Woody Vine Stratum (Plot size: _____)				
1. _____	_____	_____	_____	
2. _____	_____	_____	_____	
_____ = Total Cover				

Dominance Test worksheet:

Number of Dominant Species That Are OBL, FACW, or FAC: 1 (A)

Total Number of Dominant Species Across All Strata: 2 (B)

Percent of Dominant Species That Are OBL, FACW, or FAC: 50 (A/B)

Prevalence Index worksheet:

	Total % Cover of:	Multiply by:
OBL species	<u>40</u>	x 1 = <u>40</u>
FACW species	<u>0</u>	x 2 = <u>0</u>
FAC species	<u>0</u>	x 3 = <u>0</u>
FACU species	<u>60</u>	x 4 = <u>240</u>
UPL species	<u>0</u>	x 5 = <u>0</u>
Column Totals:	<u>100</u> (A)	<u>280</u> (B)

Prevalence Index = B/A = 2.80

Hydrophytic Vegetation Indicators:

___ Dominance Test is >50%

Prevalence Index is ≤3.0¹

___ Morphological Adaptations¹ (Provide supporting data in Remarks or on a separate sheet)

___ Problematic Hydrophytic Vegetation¹ (Explain)

¹Indicators of hydric soil and wetland hydrology must be present, unless disturbed or problematic.

Remarks: (Include photo numbers here or on a separate sheet.) Hydrophytic vegetation was present within the sample point.	Hydrophytic Vegetation Present? Yes <input checked="" type="checkbox"/> No _____
--	---

SOIL

Sampling Point: 4A

Profile Description: (Describe to the depth needed to document the indicator or confirm the absence of indicators.)

Depth (inches)	Matrix		Redox Features				Texture	Remarks
	Color (moist)	%	Color (moist)	%	Type ¹	Loc ²		
0-6"	10 YR 3/2	100			C	M	SiCL	
6-14"	10 YR 2/1	95	10 YR 4/4	5	C	M	SiCL	fill material was observed
14-18"	10 YR 4/3	100			C	M	SiCL	

¹Type: C=Concentration, D=Depletion, RM=Reduced Matrix, CS=Covered or Coated Sand Grains. ²Location: PL=Pore Lining, M=Matrix.

Hydric Soil Indicators:

- Histosol (A1)
- Histic Epipedon (A2)
- Black Histic (A3)
- Hydrogen Sulfide (A4)
- Stratified Layers (A5)
- 2 cm Muck (A10)
- Depleted Below Dark Surface (A11)
- Thick Dark Surface (A12)
- Sandy Mucky Mineral (S1)
- 5 cm Mucky Peat or Peat (S3)

- Sandy Gleyed Matrix (S4)
- Sandy Redox (S5)
- Stripped Matrix (S6)
- Loamy Mucky Mineral (F1)
- Loamy Gleyed Matrix (F2)
- Depleted Matrix (F3)
- Redox Dark Surface (F6)
- Depleted Dark Surface (F7)
- Redox Depressions (F8)

Indicators for Problematic Hydric Soils³:

- Coast Prairie Redox (A16)
- Iron-Manganese Masses (F12)
- Other (Explain in Remarks)

³Indicators of hydrophytic vegetation and wetland hydrology must be present, unless disturbed or problematic.

Restrictive Layer (if observed):

Type: _____
 Depth (inches): _____

Hydric Soil Present? Yes _____ No X

Remarks:

Hydric soil was not noted within the sample point.

HYDROLOGY

Wetland Hydrology Indicators:

Primary Indicators (minimum of one is required; check all that apply)

- Surface Water (A1)
- High Water Table (A2)
- Saturation (A3)
- Water Marks (B1)
- Sediment Deposits (B2)
- Drift Deposits (B3)
- Algal Mat or Crust (B4)
- Iron Deposits (B5)
- Inundation Visible on Aerial Imagery (B7)
- Sparsely Vegetated Concave Surface (B8)

- Water-Stained Leaves (B9)
- Aquatic Fauna (B13)
- True Aquatic Plants (B14)
- Hydrogen Sulfide Odor (C1)
- Oxidized Rhizospheres on Living Roots (C3)
- Presence of Reduced Iron (C4)
- Recent Iron Reduction in Tilled Soils (C6)
- Thin Muck Surface (C7)
- Gauge or Well Data (D9)
- Other (Explain in Remarks)

Secondary Indicators (minimum of two required)

- Surface Soil Cracks (B6)
- Drainage Patterns (B10)
- Dry-Season Water Table (C2)
- Crayfish Burrows (C8)
- Saturation Visible on Aerial Imagery (C9)
- Stunted or Stressed Plants (D1)
- Geomorphic Position (D2)
- FAC-Neutral Test (D5)

Field Observations:

Surface Water Present? Yes _____ No X Depth (inches): _____
 Water Table Present? Yes _____ No X Depth (inches): _____
 Saturation Present? Yes _____ No X Depth (inches): >18"
 (includes capillary fringe)

Wetland Hydrology Present? Yes _____ No X

Describe Recorded Data (stream gauge, monitoring well, aerial photos, previous inspections), if available:

Remarks:

Wetland hydrology criteria was not met.

APPENDIX D

Habitat Score Sheet

OBSERVER: Rob Vanni
DATE: August 20, 2020
LOCATION: WOUS #1 (Crow Creek)

WILDLIFE HABITAT/USE EVALUATION SCORE SHEET

To assess the existing and/or potential wildlife habitat use of the subject wetland, the applicant must first complete this score sheet. The attached documentation provides examples of each scoring parameter.

A separate sheet must be completed for each wetland being considered.

Applicants must document their basis for scoring decisions with field surveys, current photographs, aerial photographs, and other appropriate information.

A. Utilization by Wildlife

<u>Wildlife Use</u>	<u>Score</u>	
Significant	3	
Evident	2	
Low	1	
Occasional	0.5	
Non-Existent	0	
		SUB-TOTAL SCORE = 2

Response: Several mallard ducks and one Great Egret was observed.

B. Interspersion of Vegetative Cover

<u>Interspersion</u>	<u>Score</u>	
High	3	
Medium	2	
Low	1	
		SUB-TOTAL SCORE = 1

C. Vegetative Cover to Open Water

<u>Cover</u>	<u>Score</u>	
>95% Cover	0.5	
76% - 95% Cover, Peripheral	1.5	
76% - 95% Cover, Various	2.5	
26% - 75% Cover, Peripheral	2.0	
26% - 75% Cover, Patches	3.0	
5% - 25% Cover, Peripheral	1.0	
<5% Cover	0.5	
		SUB-TOTAL SCORE = 0.5

TOTAL SCORE (A+B+C) = 3.5

Total score \geq 5.00 apply Ludwig Wildlife Methodology
Total score $<$ 5.00 no further wildlife analysis is necessary

OBSERVER: Rob Vanni
DATE: August 20, 2020
LOCATION: Wetland A

WILDLIFE HABITAT/USE EVALUATION SCORE SHEET

To assess the existing and/or potential wildlife habitat use of the subject wetland, the applicant must first complete this score sheet. The attached documentation provides examples of each scoring parameter.

A separate sheet must be completed for each wetland being considered.

Applicants must document their basis for scoring decisions with field surveys, current photographs, aerial photographs, and other appropriate information.

A. Utilization by Wildlife

<u>Wildlife Use</u>	<u>Score</u>	
Significant	3	
Evident	2	
Low	1	
Occasional	0.5	
Non-Existent	0	SUB-TOTAL SCORE = 1.0

Response: One deer bed was noted within the tall vegetation.

B. Interspersion of Vegetative Cover

<u>Interspersion</u>	<u>Score</u>	
High	3	
Medium	2	
Low	1	SUB-TOTAL SCORE = 1

C. Vegetative Cover to Open Water

<u>Cover</u>	<u>Score</u>	
>95% Cover	0.5	
76% - 95% Cover, Peripheral	1.5	
76% - 95% Cover, Various	2.5	
26% - 75% Cover, Peripheral	2.0	
26% - 75% Cover, Patches	3.0	
5% - 25% Cover, Peripheral	1.0	
<5% Cover	0.5	SUB-TOTAL SCORE = 0.5

TOTAL SCORE (A+B+C) = 2.5

Total score \geq 5.00 apply Ludwig Wildlife Methodology
Total score $<$ 5.00 no further wildlife analysis is necessary

OBSERVER: Rob Vanni

DATE: August 20, 2020

LOCATION: Pond #1

WILDLIFE HABITAT/USE EVALUATION SCORE SHEET

To assess the existing and/or potential wildlife habitat use of the subject wetland, the applicant must first complete this score sheet. The attached documentation provides examples of each scoring parameter.

A separate sheet must be completed for each wetland being considered.

Applicants must document their basis for scoring decisions with field surveys, current photographs, aerial photographs, and other appropriate information.

A. Utilization by Wildlife

<u>Wildlife Use</u>	<u>Score</u>	
Significant	3	
Evident	2	
Low	1	
Occasional	0.5	
Non-Existent	0	
		SUB-TOTAL SCORE = 2

Response: Several mallard ducks and two blue heron was observed.

B. Interspersion of Vegetative Cover

<u>Interspersion</u>	<u>Score</u>	
High	3	
Medium	2	
Low	1	
		SUB-TOTAL SCORE = 1

C. Vegetative Cover to Open Water

<u>Cover</u>	<u>Score</u>	
>95% Cover	0.5	
76% - 95% Cover, Peripheral	1.5	
76% - 95% Cover, Various	2.5	
26% - 75% Cover, Peripheral	2.0	
26% - 75% Cover, Patches	3.0	
5% - 25% Cover, Peripheral	1.0	
<5% Cover	0.5	
		SUB-TOTAL SCORE = 0.5

TOTAL SCORE (A+B+C) = **3.5**

Total score \geq 5.00 apply Ludwig Wildlife Methodology
Total score $<$ 5.00 no further wildlife analysis is necessary

Wildlife habitat use evaluation of any particular wetland should consider both the actual wildlife uses and an analysis of the habitat values related to wildlife. Habitat evaluation provides consideration of conditions for species of wildlife that may not be currently using a wetland, but preferred habitat for feeding, nesting, rearing of young, or cover is present.

Wildlife habitat/use, ideally, should be analyzed over an entire year and for some wetlands, several years' conditions should be documented. However, obvious time constraints do not allow this. Therefore, if the evaluator does not have personal knowledge of the wetland during other seasons/years and does not have training in wildlife, a degreed wildlife biologist or ecologist should be requested to complete this section of the evaluation.

A. Utilization by Wildlife

Complete the table on the evaluation form for each wildlife group for the uses listed across the top of the table using the following point system. Consider all seasons of the year in this evaluation.

Use by wildlife group within each habitat is significant in that loss or reduction of the habitat would have an adverse effect (i.e., loss of individuals) on the population of the species or overall wildlife population in the general area (township). **SCORE = 3**







Use by wildlife group within each habitat is evident or probable and loss or reduction of the habitat would have an adverse effect (i.e., loss of individuals) on the local wildlife population (surrounding sections). **SCORE = 2**

Use by wildlife group within each habitat is incidental or low in that loss or reduction of the habitat would have a negligible effect (i.e., loss of individuals) on the local wildlife population. **SCORE = 1**

Use by wildlife group within each habitat is nonexistent at any time during any year. NOTE: Use 0.5 to signify occasional use. **SCORE = 0**

B. Interspersion of Vegetative Cover

From recent aerial photographs of the wetland, determine which of the following criteria best describes the vegetative forms of the site. Determine from conditions at the peak of the growing season.

	COMMUNITY TYPE 1
	COMMUNITY TYPE 2
	COMMUNITY TYPE 3
	COMMUNITY TYPE 4
	COMMUNITY TYPE 5
	COMMUNITY TYPE 6

High interspersions of vegetation. Edge is abundant and consists of several species. Life form zones of vegetation are broken into segments of variable size and shape. Subforms of vegetation are small and scattered. **SCORE = 3**



Moderate interspersions of vegetation. Edge is moderate in length and diversity with some irregularity in the distribution of subform stands, but vegetation life forms remain largely intact. **SCORE = 2**

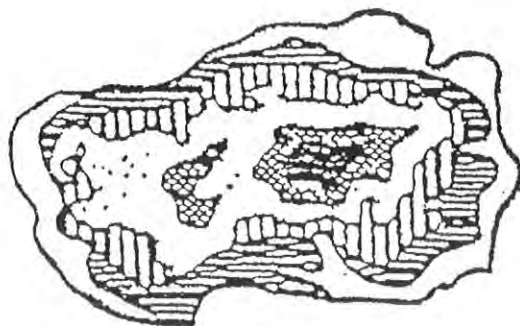

Low interspersions of vegetation. Length and types of edge are at a minimum. The wetland consists of concentric life forms and subforms. Subform stands are large and continuous. **SCORE = 1**

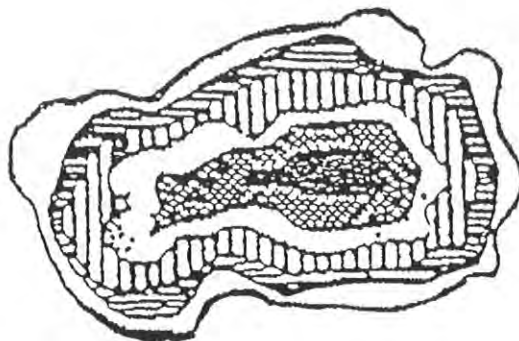

C. Vegetative Cover to Open Water

From a recent aerial photograph of the wetland, determine which of the following criteria best describes the vegetation/open water characteristics of the wetland. NOTE: Wetland cover types: white areas indicate water (with or without surface plants); black areas indicate emergents, shrubs, or trees.

Cover occupies more than 95% of wetland SCORE = 0.5

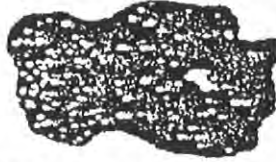

Cover occupies 76 - 95% of wetland occurring in peripheral band SCORE = 1.5

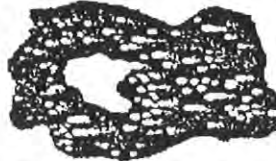

Cover occupies 76 - 95% of wetland with scattered open water SCORE = 2.5



Cover occupies 26 - 75% of wetland occurring in peripheral band SCORE = 2.0

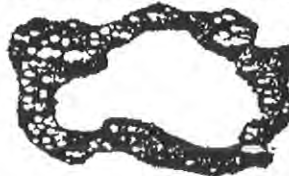

Cover occupies 26 - 75% of wetland occurring in dense patches or diffuse in open stands SCORE = 3.0



Cover occupies 5 - 25% of wetland occurring in peripheral band or diffuse in open stands SCORE = 1.0



Cover occupies less than 5% of wetland SCORE = 0.5



EXHIBIT F

USACOE JURISDICTIONAL
DETERMINATION LETTER



DEPARTMENT OF THE ARMY
CHICAGO DISTRICT, CORPS OF ENGINEERS
231 SOUTH LASALLE STREET
CHICAGO, ILLINOIS 60604-1437

REPLY TO
ATTENTION OF:

November 23, 2020

Operations Division
Regulatory Branch
LRC-2020-00994

SUBJECT: Jurisdictional Determination for Lizzie's Garden, Located at 24251 111th Street in Naperville, Will County, Illinois (Latitude 41.682, Longitude -88.210853)

Andrew Mouw
Lennar Homes
1141 East Main Street
Des Plaines, Illinois 60018

Dear Mr. Mouw:

This is in response to your request that the U.S. Army Corps of Engineers complete a jurisdictional determination for the above-referenced site submitted on your behalf by Midwest Ecological. The subject project has been assigned number LRC-2020-00994. Please reference this number in all future correspondence concerning this project.

Following a review of the information you submitted, this office has determined that the subject property contains "waters of the United States".

Waters of the U.S. 1 has been determined to be under the jurisdiction of this office and therefore, subject to Federal regulation.

Pond 1 & Wetland A have been determined to be excluded water features, and therefore not subject to Federal regulation. Please be informed that this office does not concur with the boundaries of waters not under the jurisdiction of this office.

This office concurs with the submitted wetland delineation, and wetland boundaries at the subject site. This confirmation is valid for a period of five years from the date of this letter unless new information warrants revision of the delineation prior to the expiration date.

For a detailed description of our determination please refer to the enclosed decision document. This determination covers only your project as depicted in the Wetland Delineation Report dated October 28, 2020, prepared by Midwest Ecological.

This determination is valid for a period of five (5) years from the date of the letter, unless new information warrants revision of the determination before the expiration date or a District Commander has identified, after public notice and comment, that specific geographic areas with rapidly changing environmental conditions merit re-verification on a more frequent basis.

This letter is considered an approved jurisdictional determination for your subject site. If you object to this determination, you may appeal, according to 33 CFR Part 331. Enclosed you will find a Notification of Appeal Process (NAP) fact sheet and a Request for Appeal (RFA) form. If you request to appeal the above determination, you must submit a completed RFA form to the Great Lakes/Ohio River Division Office at the following address:

Jacob Siegrist
Regulatory Appeals Review Officer
US Army Corps of Engineers
Great Lakes and Ohio River Division
550 Main Street, Room 10-714
Cincinnati, Ohio 45202-3222
Phone: (513) 684-2699 Fax: (513) 684-2460

In order to be accepted, your RFA must be complete, meet the criteria for appeal and be received by the Division Office within sixty (60) days of the date of the NAP. If you concur with the determination in this letter, submittal of the RFA form to the Division office is not necessary.

This determination has been conducted to identify the limits of the Corps Clean Water Act jurisdiction for the particular site identified in this request. This determination may not be valid for the wetland conservation provisions of the Food Security Act of 1985, as amended. If you or your tenant are USDA program participants, or anticipate participation in USDA programs, you should request a certified wetland determination from the local office of the Natural Resources Conservation Service prior to starting work.

It is your responsibility to obtain any required state, county, or local approvals for impacts to wetland areas not under the Department of the Army jurisdiction.

Pursuant to Section 404 of the Clean Water Act, the U.S. Army Corps of Engineers regulates the discharge of dredged or fill material into waters of the United States, including wetlands. A Department of the Army permit is required for any proposed work involving the discharge of dredged or fill material within the jurisdiction of this office. To initiate the permit process, please submit a joint permit application form along with detailed plans of the proposed work. Information concerning our program, including the application form and an application checklist, can be found at and downloaded from our website:

<http://www.lrc.usace.army.mil/Missions/Regulatory.aspx>

If you have any questions, please contact Mr. Michael J. Machalek of my staff by telephone at (312) 846-5534 or email at Mike.J.Machalek@usace.army.mil.

Sincerely,

Diedra L. McLaurin
Team Leader, West Section
Regulatory Branch

Enclosures

Copy Furnished w/out Enclosures

Will County Land Use Department (Jim Song)
Midwest Ecological (Rob Vanni)

NOTIFICATION OF ADMINISTRATIVE APPEAL OPTIONS AND PROCESS AND REQUEST FOR APPEAL

Applicant: Andrew Mouw, Lennar Homes

File Number: LRC-2020-00994

Date: November 23,
2020

Attached is:

See Section below

	INITIAL PROFFERED PERMIT (Standard Permit or Letter of Permission)	A
	PROFFERED PERMIT (Standard Permit or Letter of Permission)	B
	PERMIT DENIAL	C
X	APPROVED JURISDICTIONAL DETERMINATION	D
	PRELIMINARY JURISDICTIONAL DETERMINATION	E

SECTION I - The following identifies your rights and options regarding an administrative appeal of the above decision. Additional information may be found at http://www.usace.army.mil/CECW/Pages/reg_materials.aspx or Corps regulations at 33 CFR Part 331.

A. INITIAL PROFFERED PERMIT: You may accept or object to the permit.

- **ACCEPT:** If you received a Standard Permit or a Letter of Permission (LOP), you may sign the permit document and return it to the district commander for final authorization. Your signature on the Standard Permit or acceptance of the LOP means that you accept the permit in its entirety, and waive all rights to appeal the permit, including its terms and conditions, and approved jurisdictional determinations associated with the permit.
- **OBJECT:** If you object to the permit (Standard or LOP) because of certain terms and conditions therein, you may request that the permit be modified accordingly. You must complete Section II of this form and return the form to the district commander. Your objections must be received by the district commander within 60 days of the date of this notice, or you will forfeit your right to appeal the permit in the future. Upon receipt of your letter, the district commander will evaluate your objections and may: (a) modify the permit to address all of your concerns, (b) modify the permit to address some of your objections, or (c) not modify the permit having determined that the permit should be issued as previously written. After evaluating your objections, the district commander will send you a proffered permit for your reconsideration, as indicated in Section B below.

B. PROFFERED PERMIT: You may accept or appeal the permit

- **ACCEPT:** If you received a Standard Permit or a Letter of Permission (LOP), you may sign the permit document and return it to the district commander for final authorization. Your signature on the Standard Permit or acceptance of the LOP means that you accept the permit in its entirety, and waive all rights to appeal the permit, including its terms and conditions, and approved jurisdictional determinations associated with the permit.
- **APPEAL:** If you choose to decline the proffered permit (Standard or LOP) because of certain terms and conditions therein, you may appeal the declined permit under the Corps of Engineers Administrative Appeal Process by completing Section II of this form and sending the form to the division commander. This form must be received by the division commander within 60 days of the date of this notice.

C. PERMIT DENIAL: You may appeal the denial of a permit under the Corps of Engineers Administrative Appeal Process by completing Section II of this form and sending the form to the division commander. This form must be received by the division commander within 60 days of the date of this notice.

D. APPROVED JURISDICTIONAL DETERMINATION: You may accept or appeal the approved JD or provide new information.

- **ACCEPT:** You do not need to notify the Corps to accept an approved JD. Failure to notify the Corps within 60 days of the date of this notice, means that you accept the approved JD in its entirety, and waive all rights to appeal the approved JD.
- **APPEAL:** If you disagree with the approved JD, you may appeal the approved JD under the Corps of Engineers Administrative Appeal Process by completing Section II of this form and sending the form to the division commander. This form must be received by the division commander within 60 days of the date of this notice.

E. PRELIMINARY JURISDICTIONAL DETERMINATION: You do not need to respond to the Corps regarding the preliminary JD. The Preliminary JD is not appealable. If you wish, you may request an approved JD (which may be appealed), by contacting the Corps district for further instruction. Also, you may provide new information for further consideration by the Corps to reevaluate the JD.

SECTION II - REQUEST FOR APPEAL or OBJECTIONS TO AN INITIAL PROFFERED PERMIT

REASONS FOR APPEAL OR OBJECTIONS: (Describe your reasons for appealing the decision or your objections to an initial proffered permit in clear concise statements. You may attach additional information to this form to clarify where your reasons or objections are addressed in the administrative record.)

ADDITIONAL INFORMATION: The appeal is limited to a review of the administrative record, the Corps memorandum for the record of the appeal conference or meeting, and any supplemental information that the review officer has determined is needed to clarify the administrative record. Neither the appellant nor the Corps may add new information or analyses to the record. However, you may provide additional information to clarify the location of information that is already in the administrative record.

POINT OF CONTACT FOR QUESTIONS OR INFORMATION:

If you have questions regarding this decision and/or the appeal process you may contact:

Regulatory Branch
Chicago District Corps of Engineers
231 South LaSalle Street, Suite 1500
Chicago, IL 60604-1437
Phone: (312) 846-5530
Fax: (312) 353-4110

If you only have questions regarding the appeal process you may also contact:

Jacob Siegrist
Regulatory Appeals Review Officer
US Army Corps of Engineers
Great Lakes and Ohio River Division
550 Main Street, Room 10524
Cincinnati, Ohio 45202-3222
Phone: (513) 684-2699 Fax: (513) 684-2460

RIGHT OF ENTRY: Your signature below grants the right of entry to Corps of Commanders personnel, and any government consultants, to conduct investigations of the project site during the course of the appeal process. You will be provided a 15-day notice of any site investigation, and will have the opportunity to participate in all site investigations.

Signature of appellant or agent.

Date:

Telephone number:

EXHIBIT G

EXISTING CONDITIONS WATERSHED EXHIBIT

EXISTING WATERSHED FOR **THE BELVEDERE** NAPERVILLE, ILLINOIS



LOCATION MAP

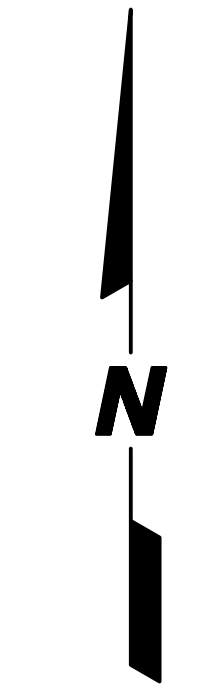

500 250 0 500
SCALE: 1 INCH = 500 FEET

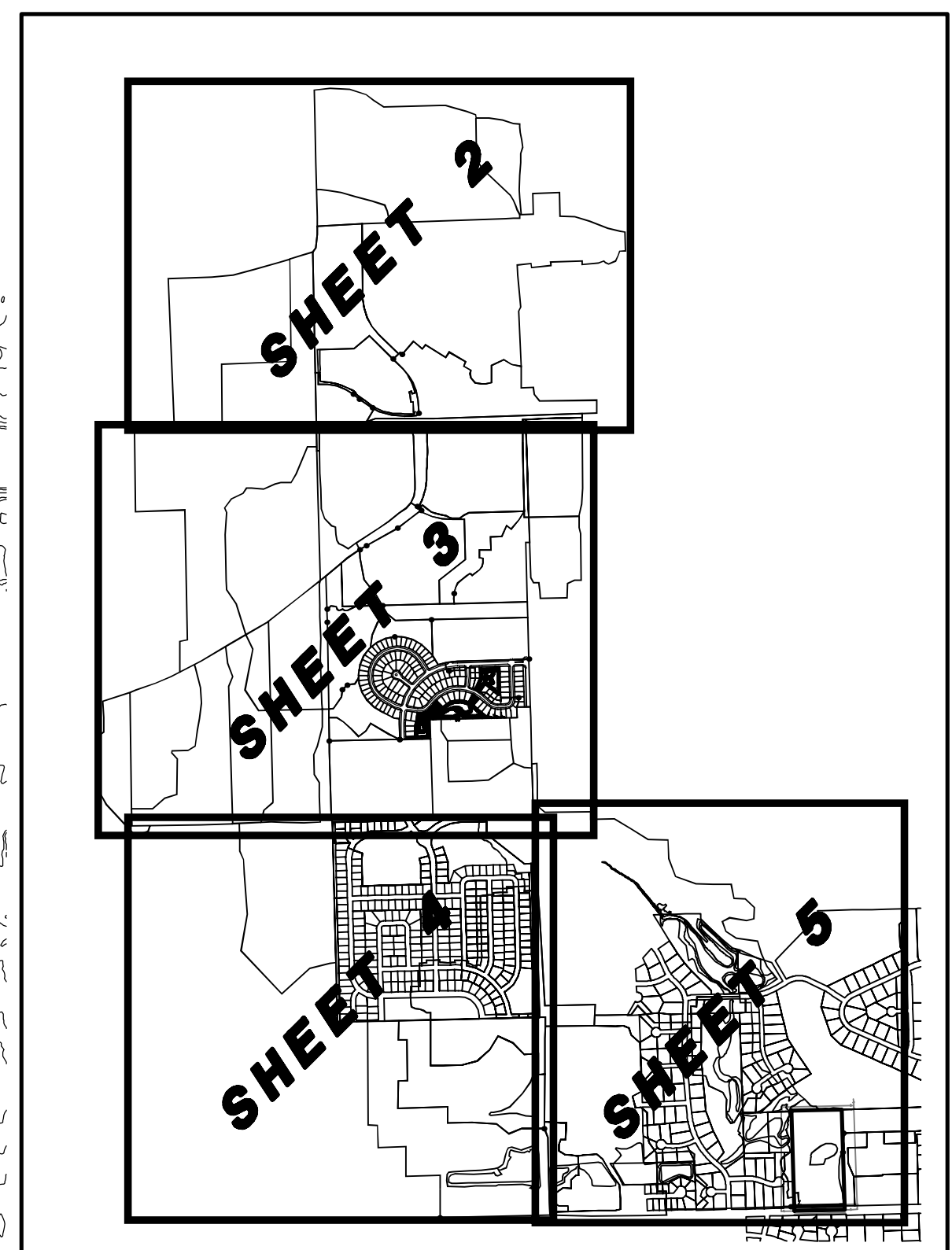
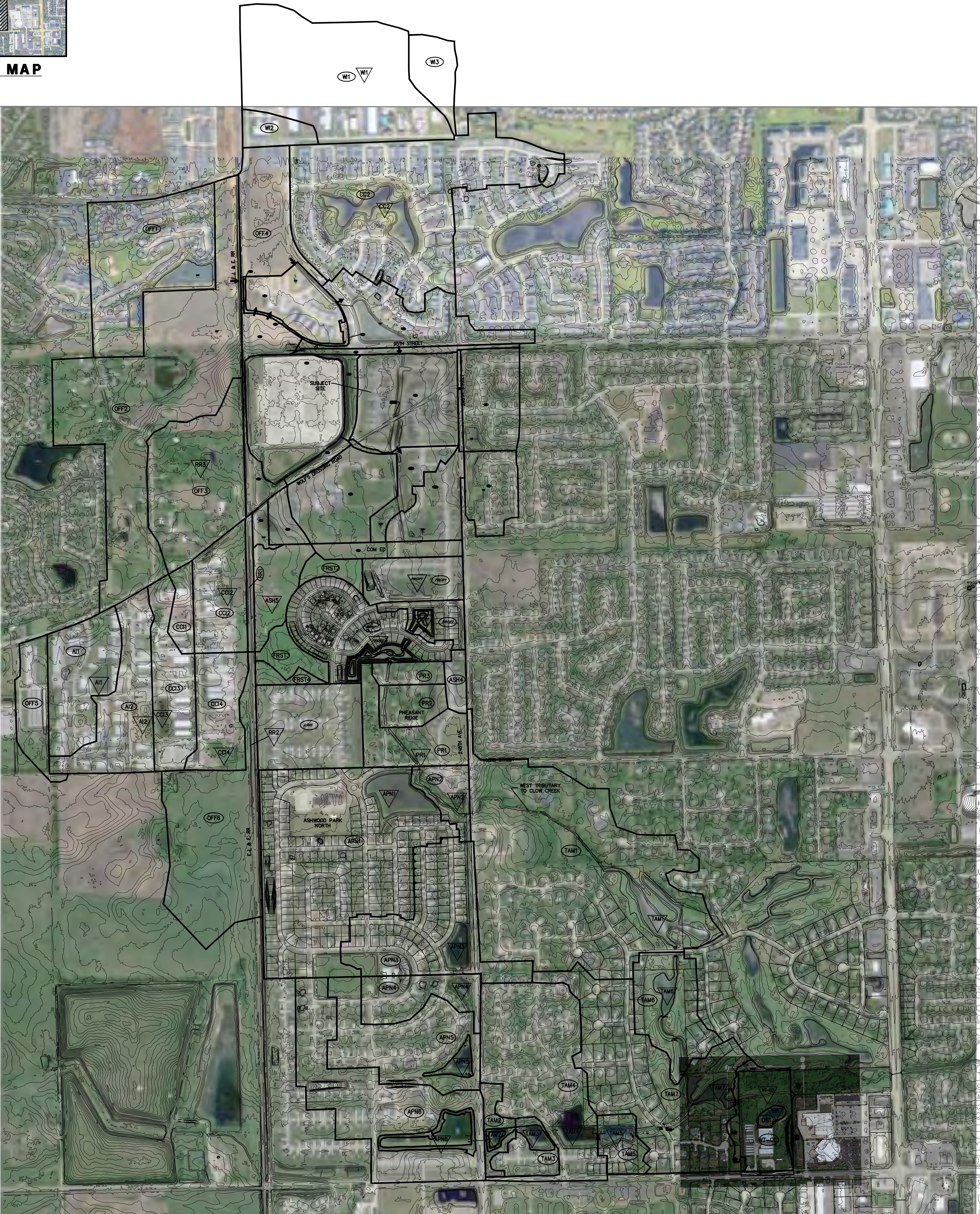

KEY MAP

PREPARED FOR:
BRIDGE CAPITAL PARTNERS
899 PINE STREET #2000
SAN FRANCISCO, CA. 94108

PREPARED BY:
CEMCON, Ltd.
Consulting Engineers, Land Surveyors & Planners
2280 White Oak Circle, Suite 100
Aurora, Illinois 60502-9675
PH: 630.862.2100 FAX: 630.862.2199
E-Mail: info@cemcon.com Website: www.cemcon.com

DISC NO.: 904411 FILE NAME: WTRSHD EXIST
DRAWN BY: KMS FLD. BK. / PG. NO.: -----
COMPLETION DATE: 03-29-22 JOB NO.: 904.411
XREF : TOPO PROJECT MANAGER : KMM

EXISTING WATERSHED FOR THE BELVEDERE
CITY OF NAPERVILLE PROJECT NO. XX-XXXXXXX
Copyright © 2022 Cemcon, Ltd. All rights reserved.

PLT FILE CREATED: 3/29/2022 BY: KMM, STARK

EXISTING WATERSHED
FOR
THE BELVEDERE
NAPERVILLE, ILLINOIS



200 100 0 200
SCALE: 1 INCH = 200 FEET

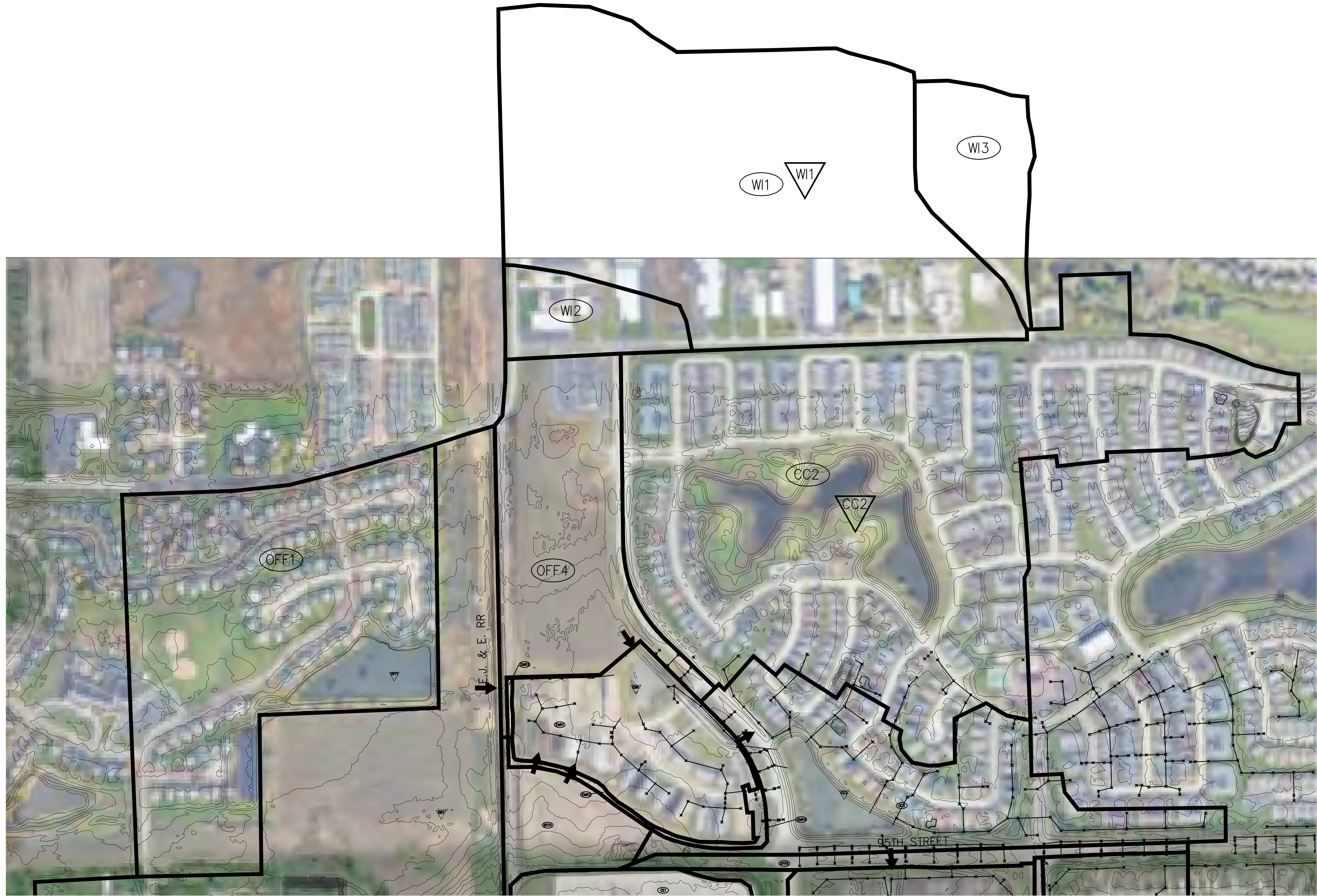

LEGEND

- - - - - 100 YR. FLOODPLAIN LIMITS
- SUB-AREA LIMITS
- CROSS-SECTION LOCATION
- △## — RESERVOIR
- RCH#### — REACH ROUTING

PREPARED FOR:
BRIDGE CAPITAL PARTNERS
899 PINE STREET #2000
SAN FRANCISCO, CA. 94108

PREPARED BY:
CEMCON, Ltd.
Consulting Engineers, Land Surveyors & Planners
2280 White Oak Circle, Suite 100
Aurora, Illinois 60502-9675
PH: 630.862.2100 FAX: 630.862.2199
E-Mail: info@cemcon.com Website: www.cemcon.com

DISC NO.: 904411 FILE NAME: WTRSHD EXIST
DRAWN BY: KMS FLD. BK. / PG. NO.: -----
COMPLETION DATE: 03-29-22 JOB NO.: 904.411
XREF : TOPO PROJECT MANAGER : KMM

EXISTING WATERSHED FOR THE BELVEDERE
CITY OF NAPERVILLE PROJECT NO. XX-XXXXXXX
Copyright © 2022 Cemcon, Ltd. All rights reserved.

PLOT FILE CREATED: 3/29/2022 BY: KRISTIN STARKEL DRAWING PATH: P:\2024\1\WTRSHD\DRAWINGS\EXISTING\WTRSHD_EXIST.DWG

EXISTING WATERSHED FOR **THE BELVEDERE** NAPERVILLE, ILLINOIS



200 100 0 200
SCALE: 1 INCH = 200 FEET



PREPARED FOR:
BRIDGE CAPITAL PARTNERS
899 PINE STREET #2000
SAN FRANCISCO, CA. 94108

LEGEND

- 100 YR. FLOODPLAIN LIMITS
- SUB-AREA LIMITS
- CROSS-SECTION LOCATION
- RESERVOIR
- REACH ROUTING

PREPARED BY:
CEMCON, Ltd.
Consulting Engineers, Land Surveyors & Planners
2280 White Oak Circle, Suite 100
Aurora, Illinois 60502-9675
PH: 630.862.2100 FAX: 630.862.2199
E-Mail: info@cemcon.com Website: www.cemcon.com

DISC NO.: 904411 FILE NAME: WTRSHD EXIST
DRAWN BY: KMS FLD. BK. / PG. NO.: -----
COMPLETION DATE: 03-29-22 JOB NO.: 904.411
XREF : TOPO PROJECT MANAGER : KMM

EXISTING WATERSHED FOR THE BELVEDERE
CITY OF NAPERVILLE PROJECT NO. XX-XXXXXXX
Copyright © 2022 Cemcon, Ltd. All rights reserved.

PLOT FILE CREATED: 3/29/2022 BY: KRISTIN STANKE

EXHIBIT H

EXISTING CONDITIONS

HEC-RAS MODEL

HEC-RAS Plan: MODEXIST River: WestTribClow Reach: WestTribClow

Reach	River Sta	Profile	Q Total (cfs)	Min Ch El (ft)	W.S. Elev (ft)	Crit W.S. (ft)	E.G. Elev (ft)	E.G. Slope (ft/ft)	Vel Chnl (ft/s)	Flow Area (sq ft)	Top Width (ft)	Froude # Chl
WestTribClow	1811	10 Yr	307.00	651.10	654.72	653.82	655.46	0.006412	6.92	44.37	12.52	0.65
WestTribClow	1811	100 Yr	418.00	651.10	655.56	654.43	656.46	0.006510	7.60	54.97	12.65	0.64
WestTribClow	1800		Culvert									
WestTribClow	1787	10 Yr	307.00	650.80	653.52	653.52	654.85	0.014925	9.27	33.10	12.38	1.00
WestTribClow	1787	100 Yr	418.00	650.80	654.13	654.13	655.77	0.015166	10.26	40.74	12.46	1.00
WestTribClow	1777	10 Yr	307.00	650.00	653.28	652.51	653.84	0.003848	6.01	51.05	25.69	0.63
WestTribClow	1777	100 Yr	418.00	650.00	653.85	652.99	654.57	0.003860	6.81	61.38	27.12	0.65
WestTribClow	1709	10 Yr	307.00	649.10	653.41	651.70	653.58	0.001263	3.37	91.00	30.92	0.35
WestTribClow	1709	100 Yr	418.00	649.10	654.06	652.08	654.28	0.001312	3.73	111.95	33.44	0.36
WestTribClow	1627	10 Yr	307.00	648.90	653.30	651.51	653.48	0.001250	3.42	89.67	30.83	0.35
WestTribClow	1627	100 Yr	418.00	648.90	653.95	651.93	654.17	0.001302	3.78	110.64	33.76	0.37
WestTribClow	1500	10 Yr	307.00	648.50	653.02	651.40	653.28	0.001768	4.11	74.63	24.90	0.42
WestTribClow	1500	100 Yr	418.00	648.50	653.63	651.89	653.96	0.001773	4.65	91.64	31.05	0.43
WestTribClow	1350	10 Yr	307.00	648.10	652.75	651.11	653.01	0.001811	4.13	74.29	24.62	0.42
WestTribClow	1350	100 Yr	418.00	648.10	653.34	651.60	653.68	0.002100	4.67	89.51	27.60	0.46
WestTribClow	1200	10 Yr	307.00	648.00	652.28	651.21	652.66	0.003021	4.94	62.14	23.34	0.53
WestTribClow	1200	100 Yr	418.00	648.00	652.76	651.69	653.26	0.003455	5.66	73.79	24.79	0.58
WestTribClow	1100	10 Yr	307.00	647.40	652.00	650.72	652.37	0.002713	4.84	63.43	22.51	0.51
WestTribClow	1100	100 Yr	418.00	647.40	652.40	651.26	652.91	0.003504	5.76	72.53	23.95	0.58
WestTribClow	1000	10 Yr	310.00	646.20	651.80	649.96	652.09	0.002418	4.32	71.77	26.80	0.47
WestTribClow	1000	100 Yr	427.00	646.20	652.10	650.55	652.54	0.003481	5.32	81.30	46.00	0.56

WestTribClow Plan: ModExist 3/23/2022
Sta: 18+11

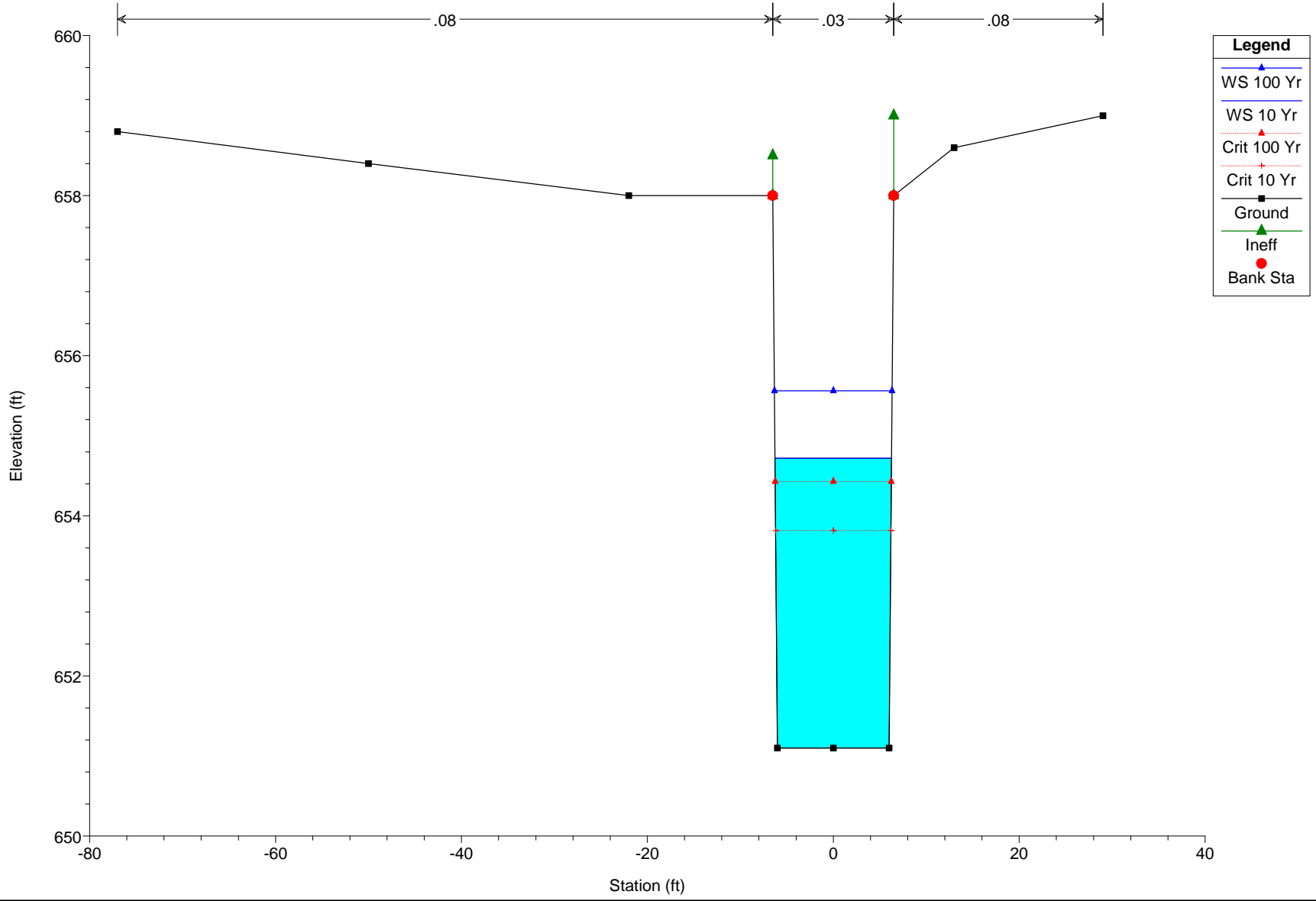

WestTribClow Plan: ModExist 3/23/2022
Box Culvert at Golf Cart Crossing (18+00)

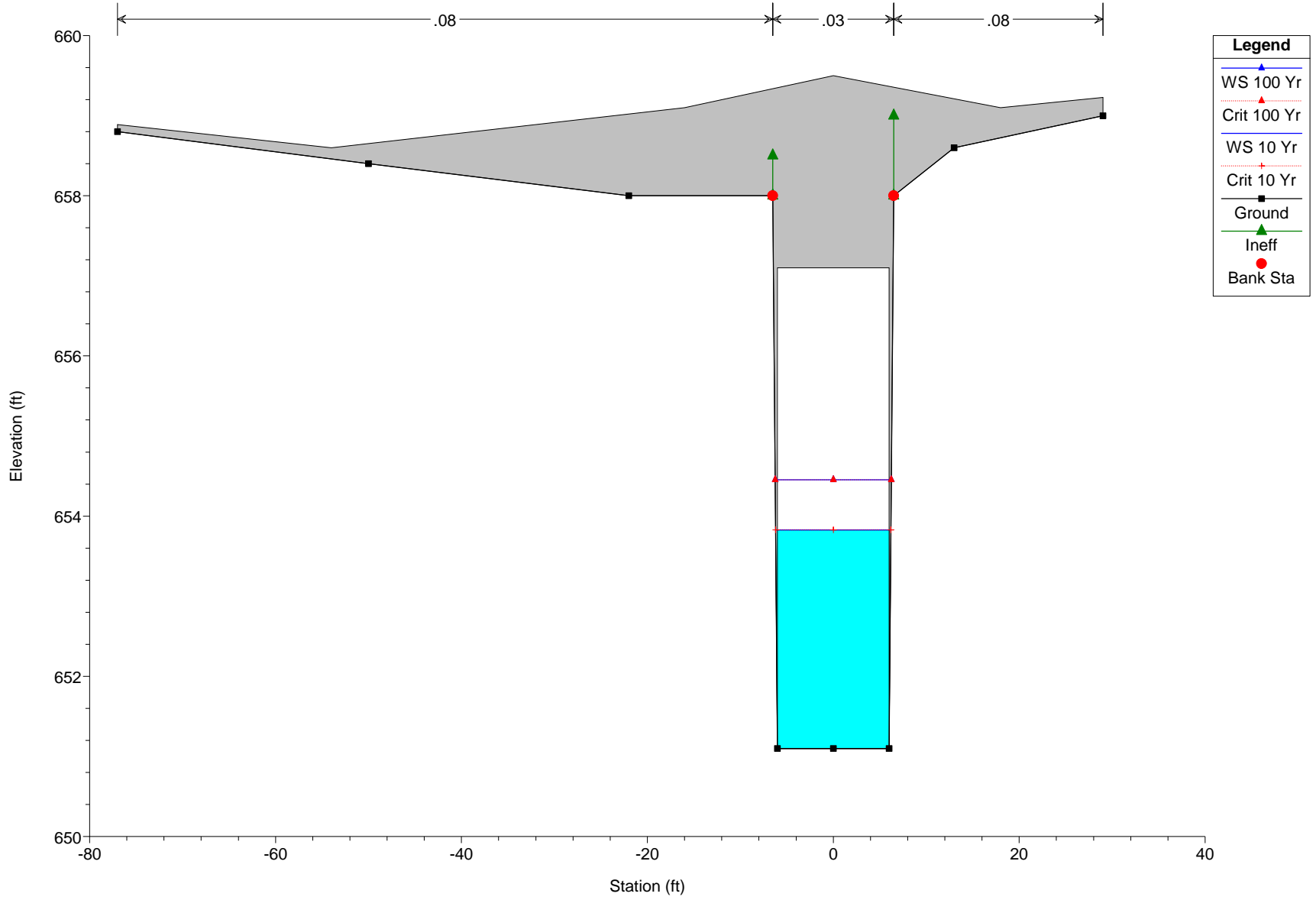

WestTribClow Plan: ModExist 3/23/2022
 Box Culvert at Golf Cart Crossing (18+00)

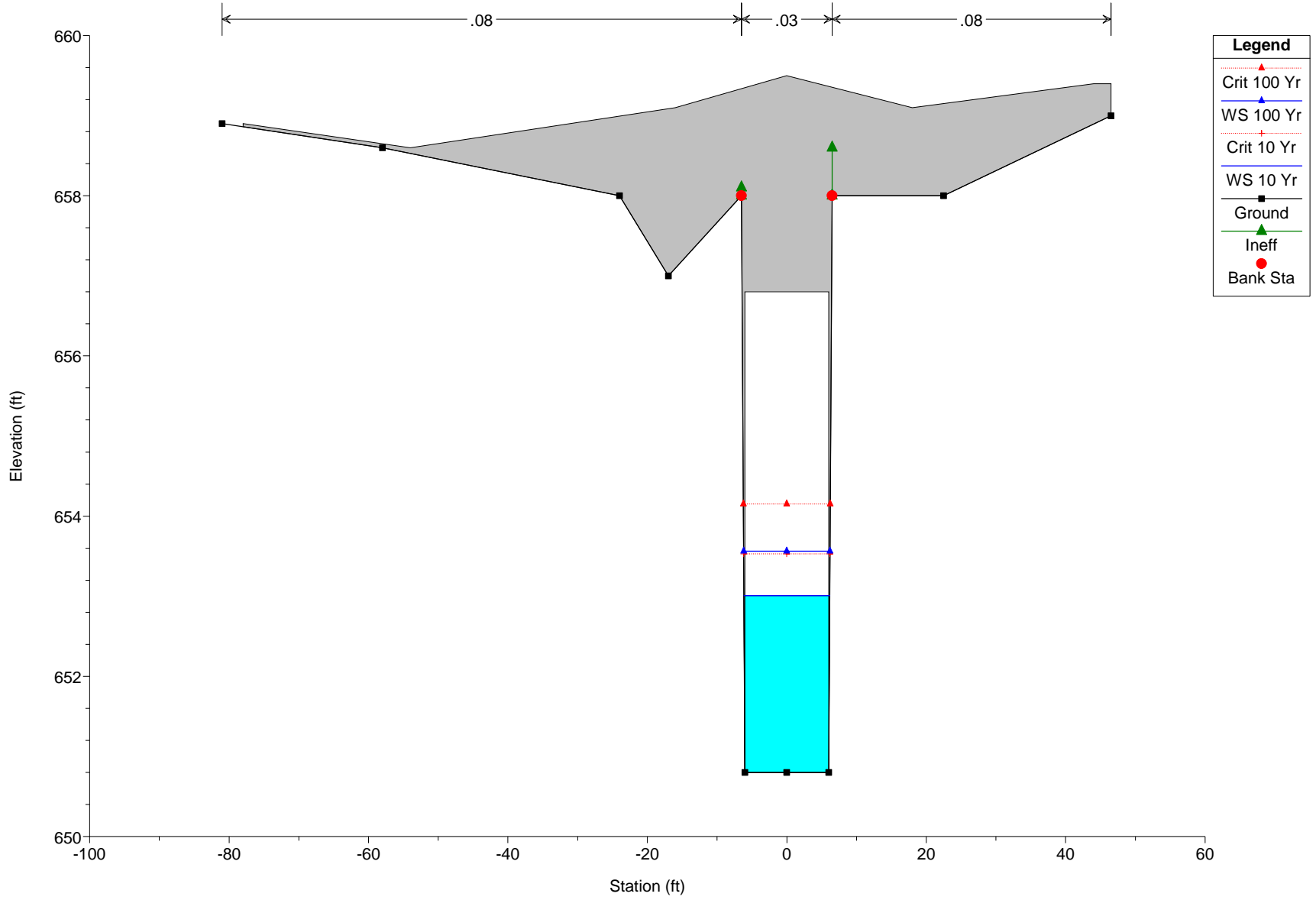

WestTribClow Plan: ModExist 3/23/2022
Sta: 17+87

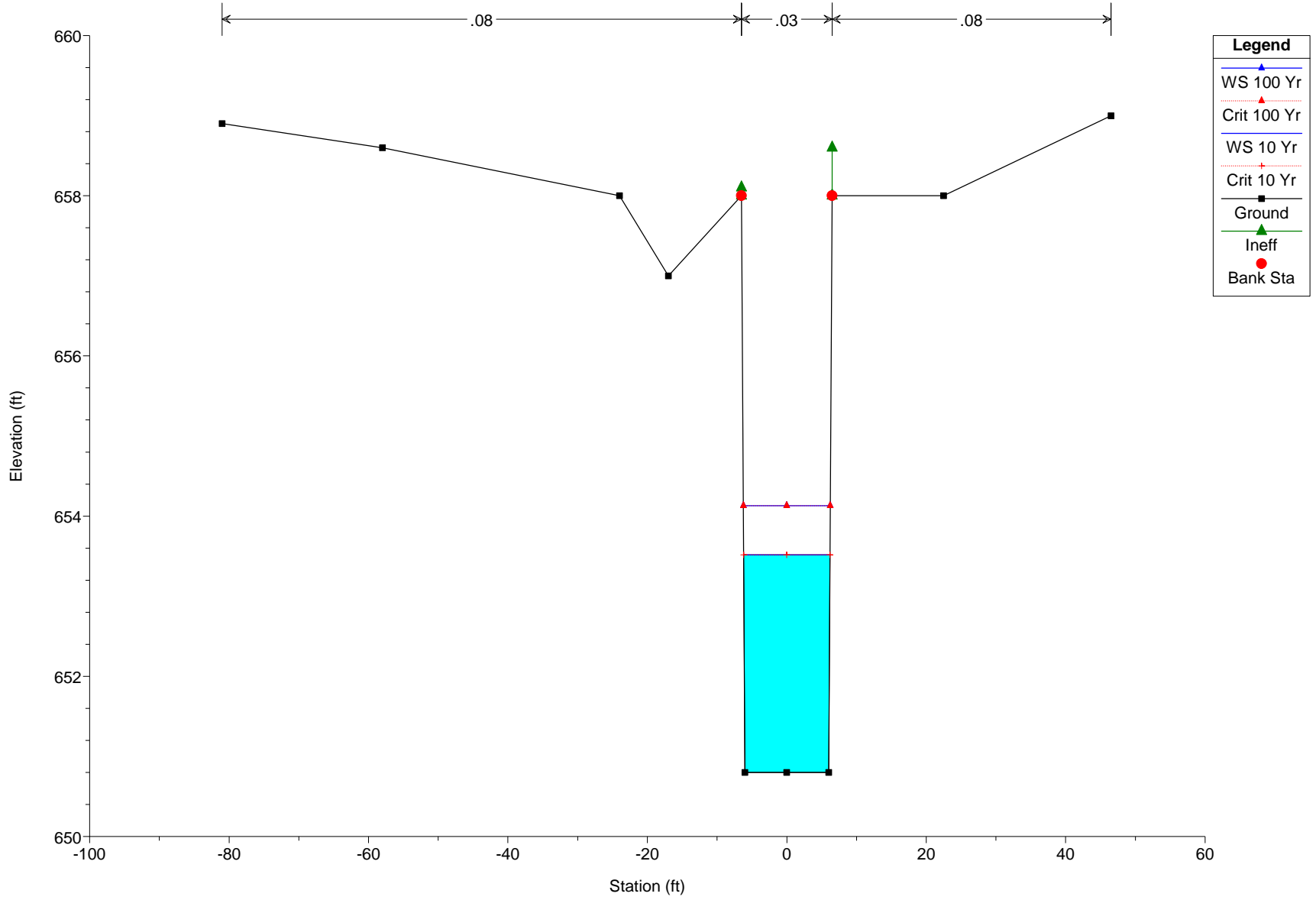

WestTribClow Plan: ModExist 3/23/2022
17+77

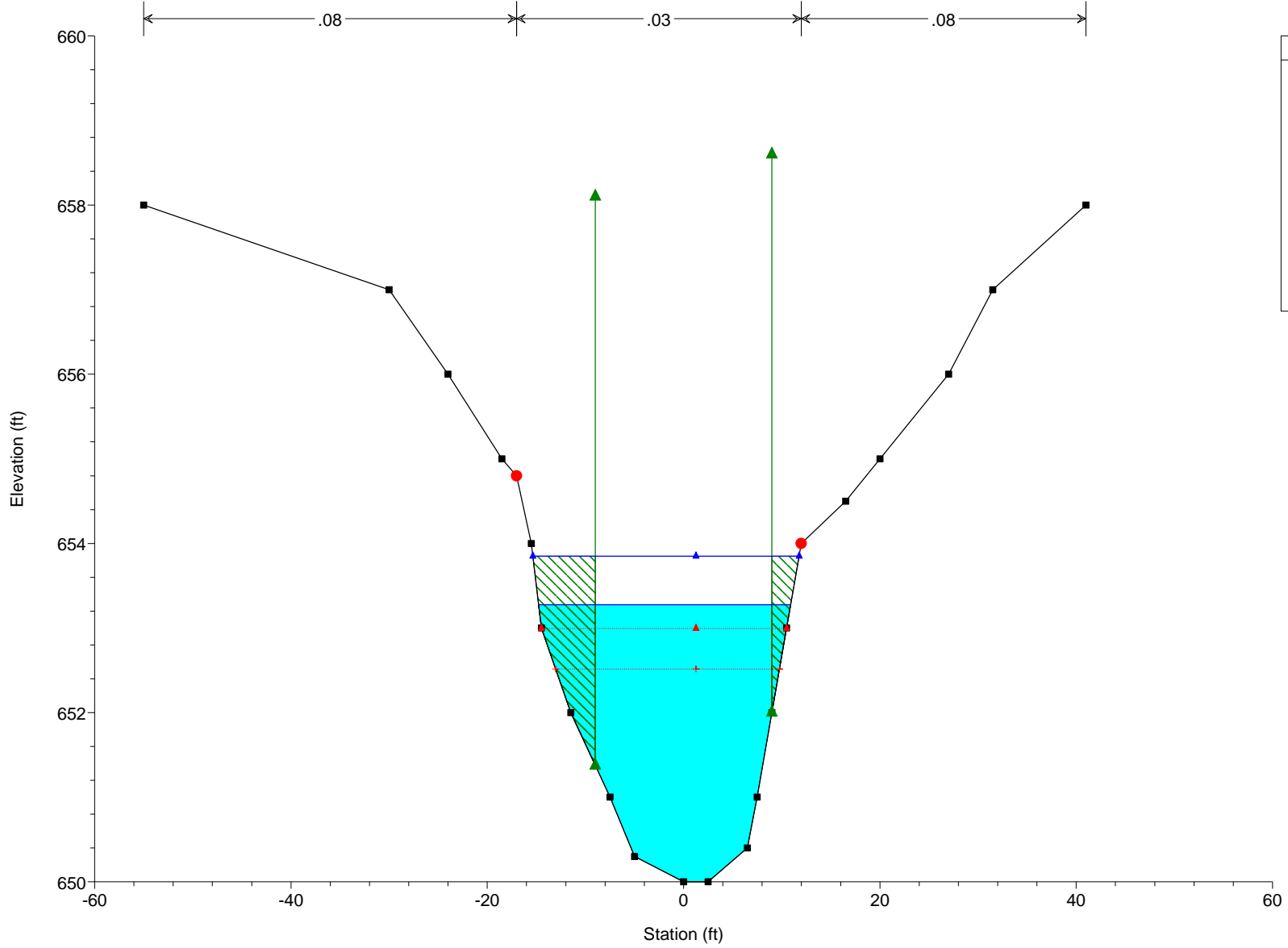

Legend	
WS 100 Yr	Blue line with triangle
WS 10 Yr	Blue line with triangle
Crit 100 Yr	Red dotted line with triangle
Crit 10 Yr	Red dotted line with triangle
Ground	Black line with square
Ineff	Green line with triangle
Bank Sta	Red circle

WestTribClow Plan: ModExist 3/23/2022
Sta 17+09

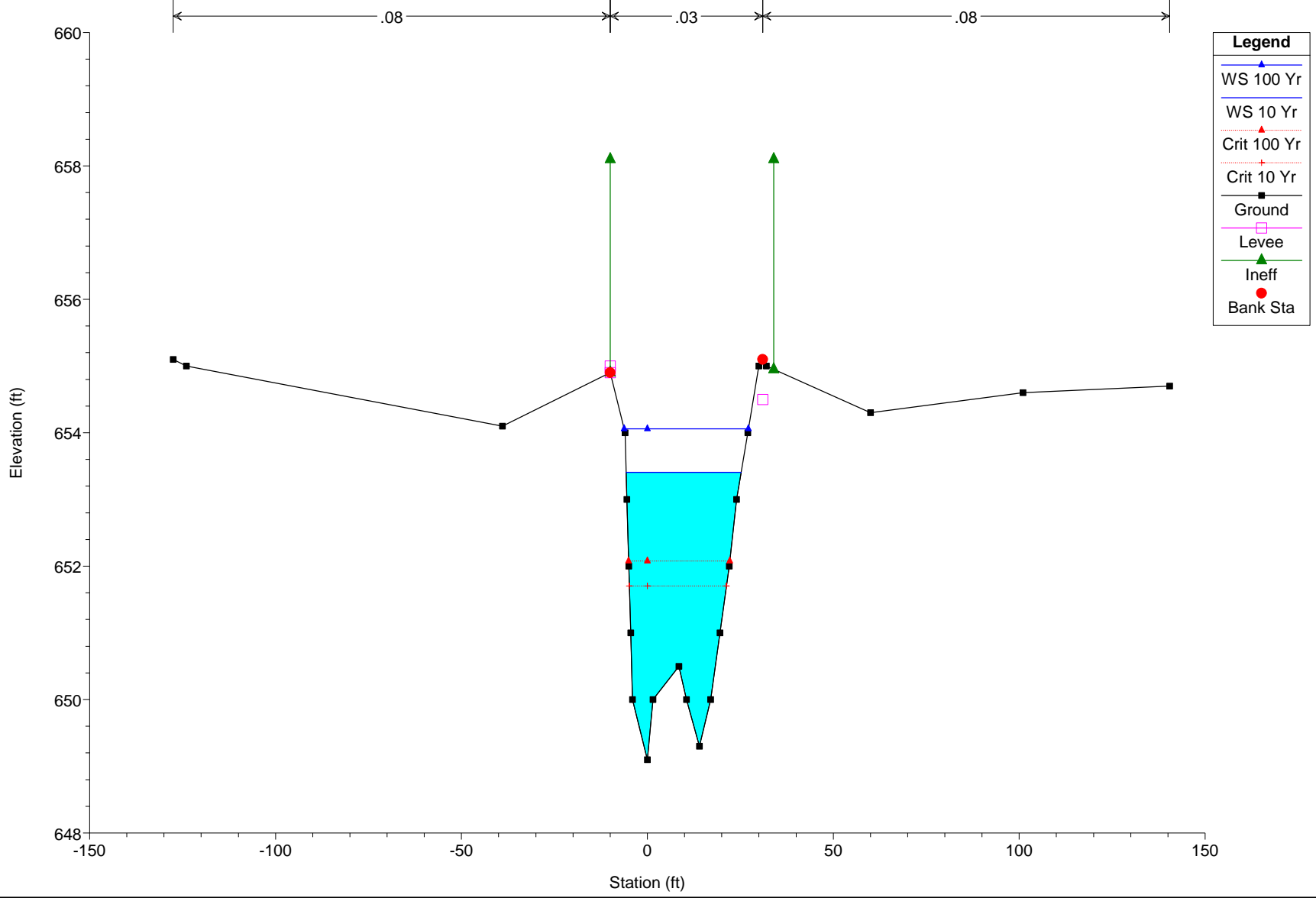

WestTribClow Plan: ModExist 3/23/2022
Sta: 15+00

← .08 → | ← .03 → | ← .08 →

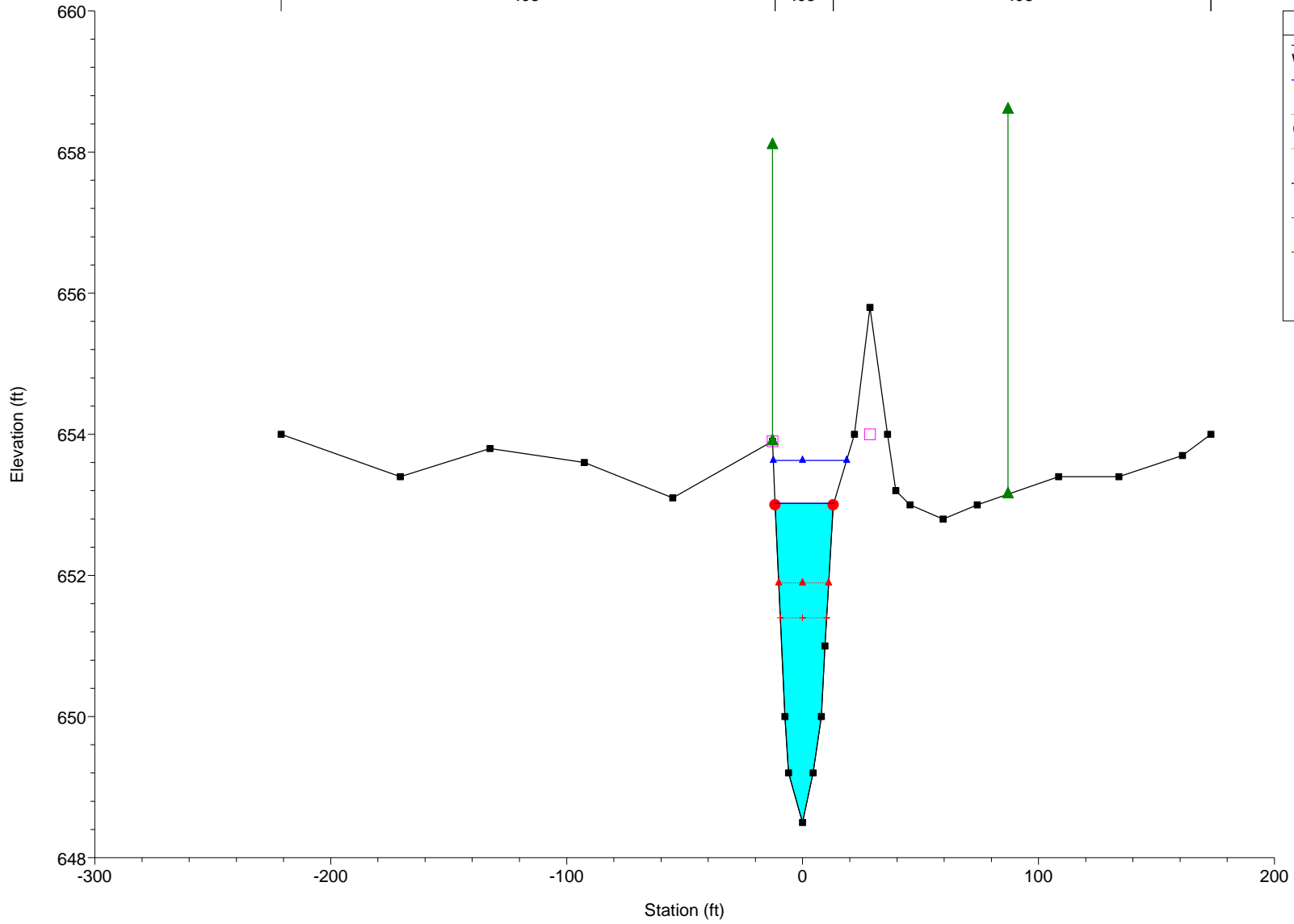

Legend

- WS 100 Yr
- WS 10 Yr
- Crit 100 Yr
- Crit 10 Yr
- Ground
- Levee
- Ineff
- Bank Sta

WestTribClow Plan: ModExist 3/23/2022

Sta 13+50

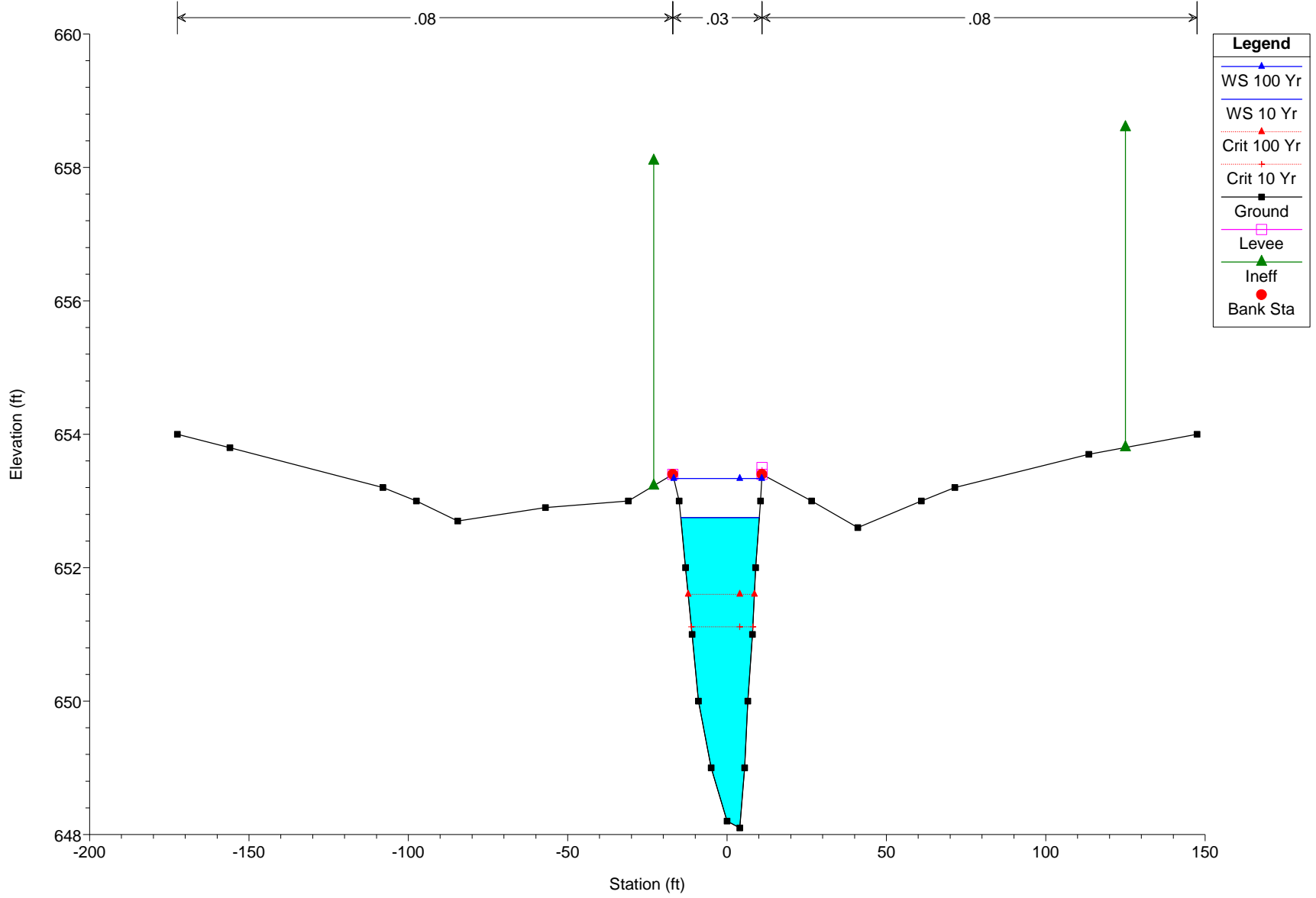

WestTribClow Plan: ModExist 3/23/2022

Sta 12+00



Legend	
WS 100 Yr	▲ (blue triangle)
WS 10 Yr	▲ (red triangle)
Crit 100 Yr	▲ (red triangle)
Crit 10 Yr	▲ (red triangle)
Ground	■ (black square)
Levee	□ (magenta square)
Ineff	▲ (green triangle)
Bank Sta	● (red circle)

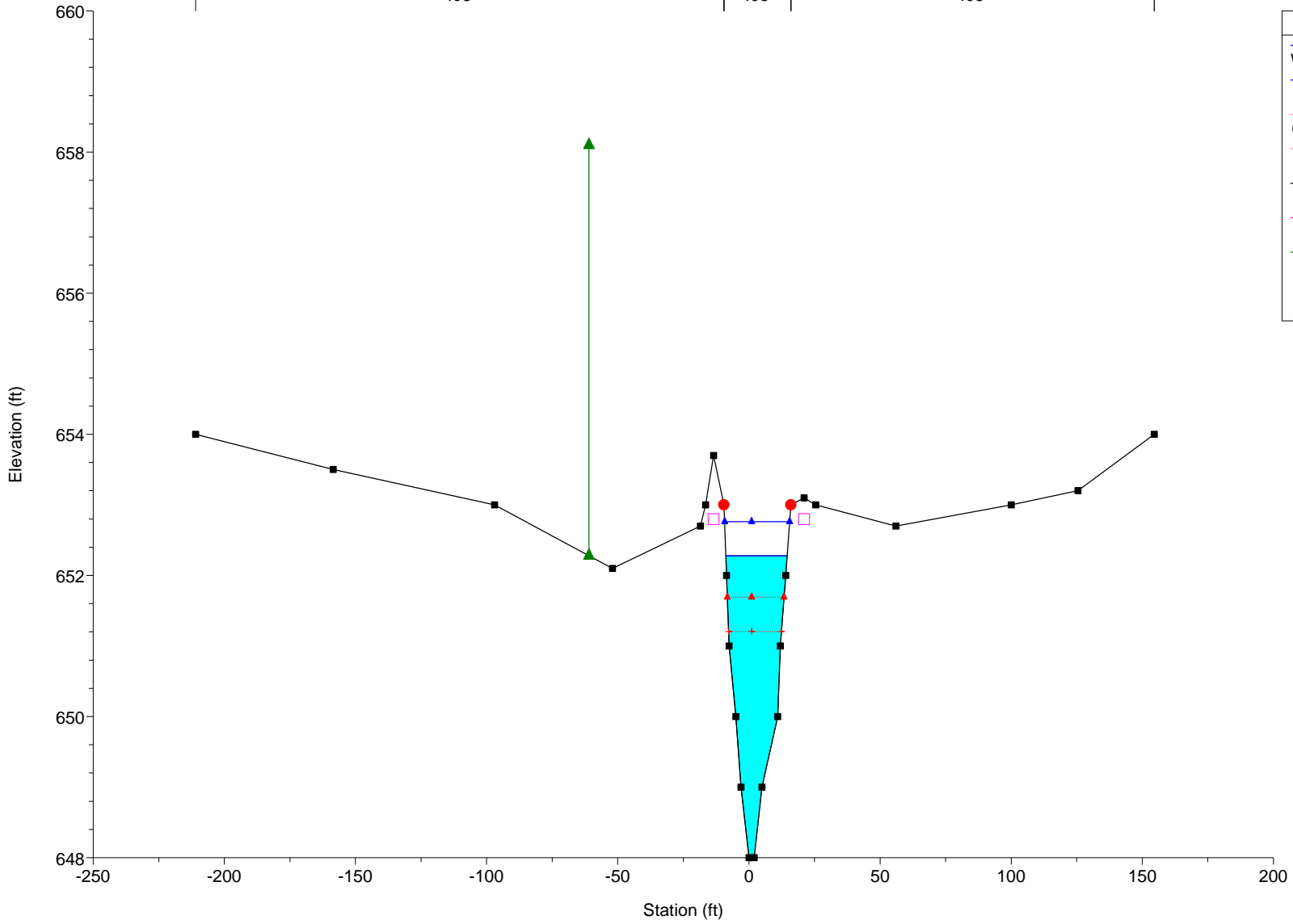

WestTribClow Plan: ModExist 3/23/2022
Sta 11+00

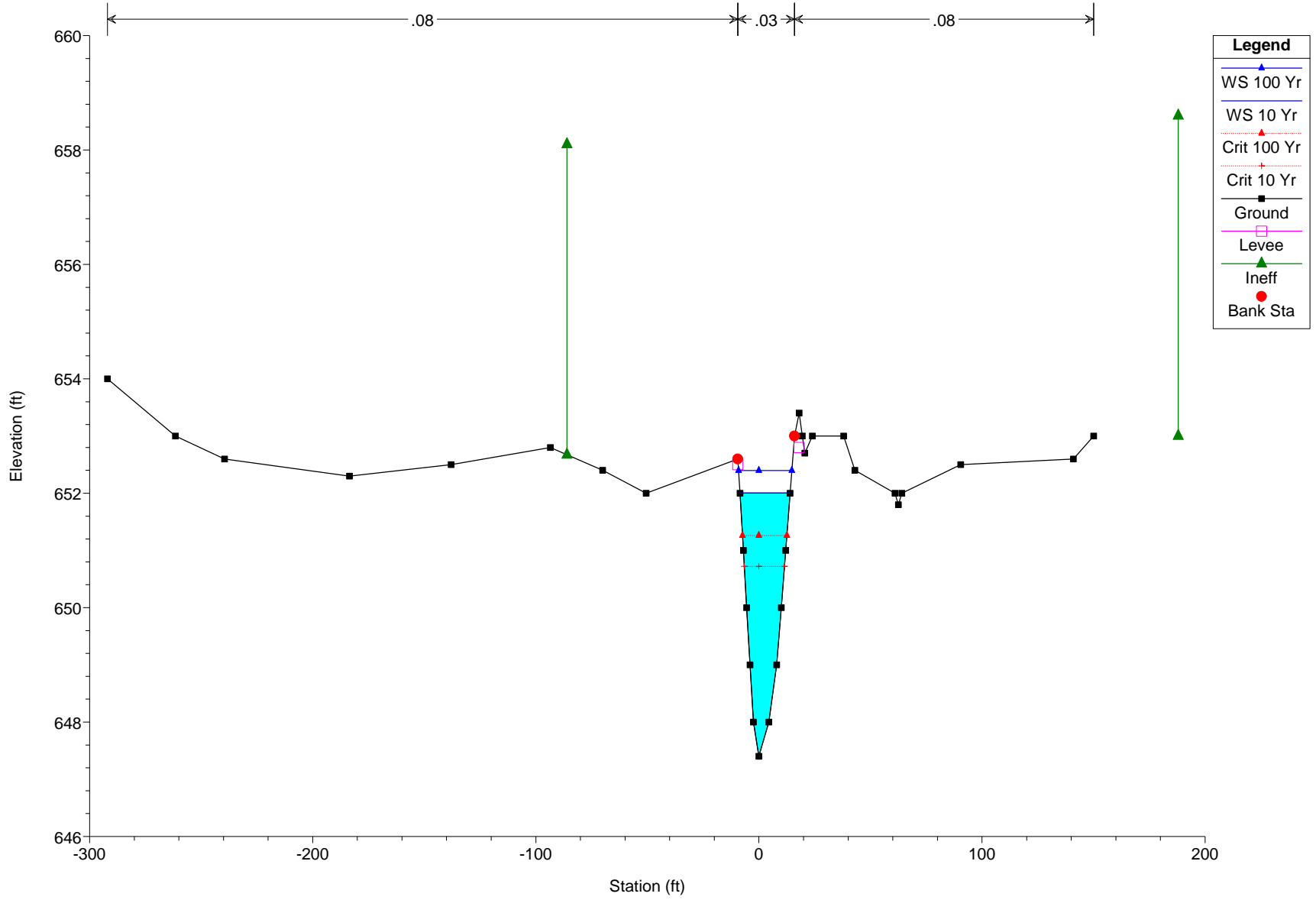

WestTribClow Plan: ModExist 3/23/2022
Sta 10+00

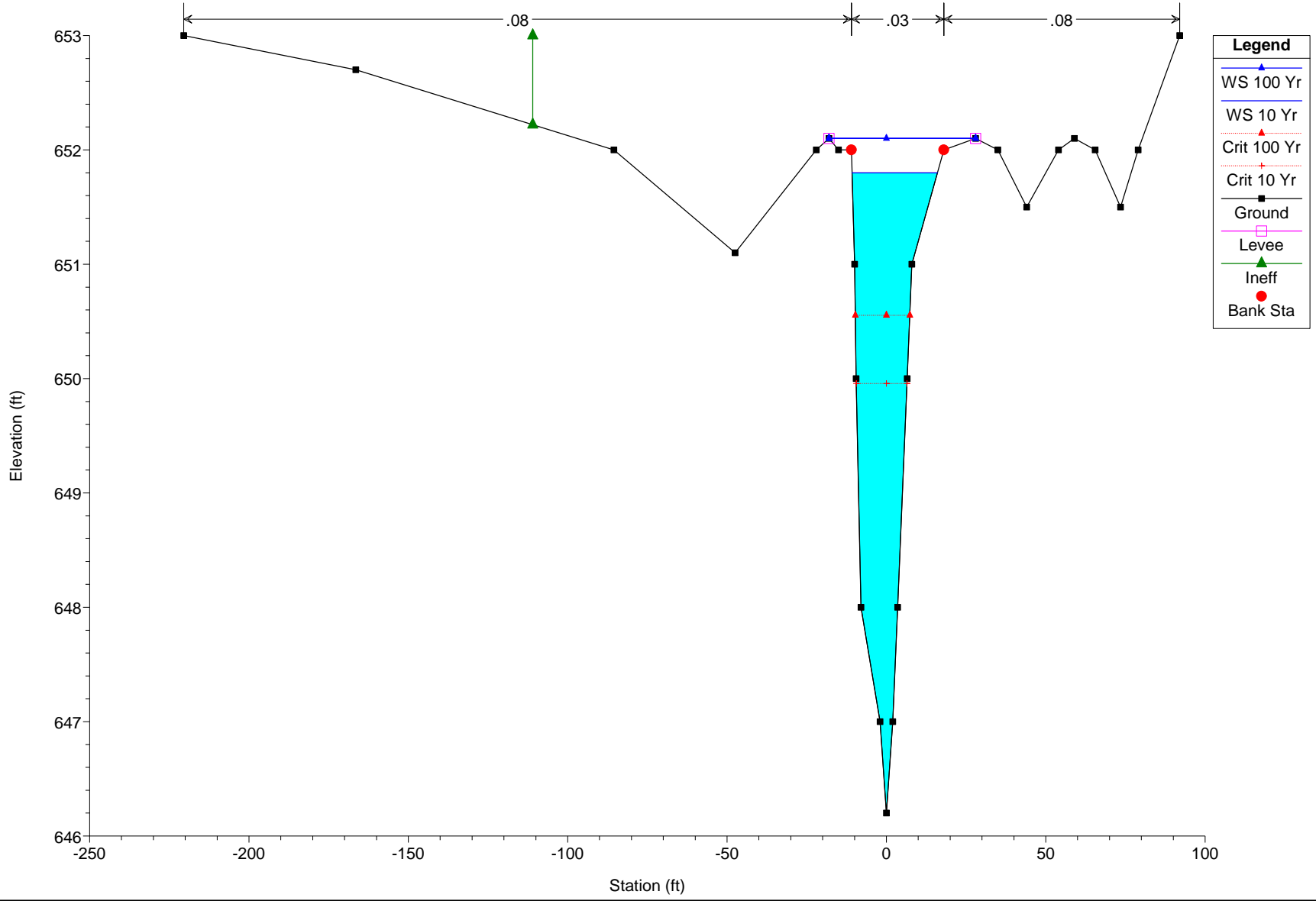

westTribClow.rep

HEC-RAS Version 4.1.0 Jan 2010
U.S. Army Corps of Engineers
Hydrologic Engineering Center
609 Second Street
Davis, California

```
X      X  XXXXXX   XXXX      XXXX      XX      XXXX
X      X  X       X      X      X      X  X      X
X      X  X       X      X      X      X  X      X
XXXXXXXX XXXX     X      XXX  XXXX     XXXXXX   XXXX
X      X  X       X      X      X      X  X      X
X      X  X       X      X      X      X  X      X
X      X  XXXXXX   XXXX     X      X      X      XXXXXX
```

PROJECT DATA

Project Title: westTribClow
Project File : westTribClow.prj
Run Date and Time: 3/23/2022 2:53:07 PM

Project in English units

Project Description:
West Tributary of Clow Creek
3-16-2022 MAM/

PLAN DATA

Plan Title: ModExist
Plan File : l:\904411\Hydro\HECRAS\westTribClow.p04

Geometry Title: ModExist
Geometry File : l:\904411\Hydro\HECRAS\westTribClow.g01

Flow Title : ModExist
Flow File : l:\904411\Hydro\HECRAS\westTribClow.f01

Plan Summary Information:

Number of:	Cross Sections =	10	Multiple Openings =	0
	Culverts =	1	Inline Structures =	0
	Bridges =	0	Lateral Structures =	0

Computational Information

Water surface calculation tolerance =	0.01
Critical depth calculation tolerance =	0.01
Maximum number of iterations =	20
Maximum difference tolerance =	0.3
Flow tolerance factor =	0.001

Computation Options

Critical depth computed only where necessary
Conveyance Calculation Method: At breaks in n values only
Friction Slope Method: Average Conveyance
Computational Flow Regime: Subcritical Flow

WestTribClow.rep

FLOW DATA

Flow Title: ModExist
 Flow File : I:\904411\Hydro\HECRAS\WestTribClow.f01

Flow Data (cfs)

River	Reach	RS	10 Yr	100 Yr
WestTribClow	WestTribClow	1811	307	418
WestTribClow	WestTribClow	1000	310	427

Boundary Conditions

River	Reach	Profile	Upstream
Downstream			
WestTribClow	WestTribClow	10 Yr	
Known WS = 651.8			
WestTribClow	WestTribClow	100 Yr	
Known WS = 652.1			

GEOMETRY DATA

Geometry Title: ModExist
 Geometry File : I:\904411\Hydro\HECRAS\WestTribClow.g01

CROSS SECTION

RIVER: WestTribClow
 REACH: WestTribClow RS: 1811

INPUT

Description: Sta: 18+11

Station Elevation Data num= 10

Sta	Elev	Sta	Elev	Sta	Elev	Sta	Elev	Sta	Elev
-77	658.8	-50	658.4	-22	658	-6.5	658	-6	651.1
0	651.1	6	651.1	6.5	658	13	658.6	29	659

Manning's n Values num= 3

Sta	n Val	Sta	n Val	Sta	n Val
-77	.08	-6.5	.03	6.5	.08

Bank Sta: Left Right Lengths: Left Channel Right Coeff Contr. Expan.

-6.5	6.5	34	34	34	.1	.3
------	-----	----	----	----	----	----

Ineffective Flow num= 2

Sta L	Sta R	Elev	Permanent
-77	-6.5	658.5	F
6.5	29	659	T

CROSS SECTION OUTPUT Profile #10 Yr

westTribClow.rep				
		Element	Left OB	Channel
E.G. Elev (ft)	655.46			
Right OB				
Vel Head (ft)	0.74	wt. n-Val.		0.030
W.S. Elev (ft)	654.72	Reach Len. (ft)	34.00	34.00
34.00				
Crit w.s. (ft)	653.82	Flow Area (sq ft)		44.37
E.G. Slope (ft/ft)	0.006412	Area (sq ft)		44.37
Q Total (cfs)	307.00	Flow (cfs)		307.00
Top width (ft)	12.52	Top width (ft)		12.52
Vel Total (ft/s)	6.92	Avg. Vel. (ft/s)		6.92
Max Chl Dpth (ft)	3.62	Hydr. Depth (ft)		3.54
Conv. Total (cfs)	3833.9	Conv. (cfs)		3833.9
Length wtd. (ft)	34.00	wetted Per. (ft)		19.26
Min Ch El (ft)	651.10	Shear (lb/sq ft)		0.92
Alpha	1.00	Stream Power (lb/ft s)	29.00	0.00
0.00		Cum Volume (acre-ft)	0.00	1.34
Frctn Loss (ft)		Cum SA (acres)	0.00	0.47
0.00				
C & E Loss (ft)				
0.00				

Note: Multiple critical depths were found at this location. The critical depth with the lowest, valid, energy was used.

CROSS SECTION OUTPUT Profile #100 Yr

		Element	Left OB	Channel
E.G. Elev (ft)	656.46			
Right OB				
Vel Head (ft)	0.90	wt. n-Val.		0.030
W.S. Elev (ft)	655.56	Reach Len. (ft)	34.00	34.00
34.00				
Crit w.s. (ft)	654.43	Flow Area (sq ft)		54.97
E.G. Slope (ft/ft)	0.006510	Area (sq ft)		54.97
Q Total (cfs)	418.00	Flow (cfs)		418.00
Top width (ft)	12.65	Top width (ft)		12.65
Vel Total (ft/s)	7.60	Avg. Vel. (ft/s)		7.60
Max Chl Dpth (ft)	4.46	Hydr. Depth (ft)		4.35
Conv. Total (cfs)	5180.7	Conv. (cfs)		5180.7
Length wtd. (ft)	34.00	wetted Per. (ft)		20.95
Min Ch El (ft)	651.10	Shear (lb/sq ft)		1.07

	WestTribClow.rep			
Alpha	1.00	Stream Power (lb/ft s)	29.00	0.00
0.00				
Frctn Loss (ft)		Cum Volume (acre-ft)	0.00	1.61
0.01				
C & E Loss (ft)		Cum SA (acres)	0.01	0.51
0.03				

Note: Multiple critical depths were found at this location. The critical depth with the lowest, valid, energy was used.

CULVERT

RIVER: WestTribClow
 REACH: WestTribClow RS: 1800

INPUT

Description: Box Culvert at Golf Cart Crossing (18+00)

Distance from Upstream XS = 7
 Deck/Roadway width = 8.5
 Weir Coefficient = 2.8

Upstream Deck/Roadway Coordinates

num=	6							
Sta	Hi Cord	Lo Cord	Sta	Hi Cord	Lo Cord	Sta	Hi Cord	Lo Cord
-78	658.9	0	-54	658.6	0	-16	659.1	0
0	659.5	0	18	659.1	0	44	659.4	0

Upstream Bridge Cross Section Data

Station Elevation Data	num=	10							
Sta	Elev	Sta	Elev	Sta	Elev	Sta	Elev	Sta	Elev
-77	658.8	-50	658.4	-22	658	-6.5	658	-6	651.1
0	651.1	6	651.1	6.5	658	13	658.6	29	659

Manning's n Values

num=	3		
Sta	n Val	Sta	n Val
-77	.08	-6.5	.03
		6.5	.08

Bank Sta: Left	Right	Coeff	Contr.	Expan.
-6.5	6.5		.1	.3

Ineffective Flow

num=	2	
Sta L	Sta R	Elev
-77	-6.5	658.5
6.5	29	659
		F
		T

Downstream Deck/Roadway Coordinates

num=	7							
Sta	Hi Cord	Lo Cord	Sta	Hi Cord	Lo Cord	Sta	Hi Cord	Lo Cord
-78	658.9	0	-54	658.6	0	-16	659.1	0
0	659.5	0	18	659.1	0	44	659.4	0
50	659.4	0						

Downstream Bridge Cross Section Data

Station Elevation Data	num=	11							
Sta	Elev	Sta	Elev	Sta	Elev	Sta	Elev	Sta	Elev
-81	658.9	-58	658.6	-24	658	-17	657	-6.5	658
-6	650.8	0	650.8	6	650.8	6.5	658	22.5	658
46.5	659								

Manning's n Values

num=	3		
Sta	n Val	Sta	n Val
-81	.08	-6.5	.03
		6.5	.08

WestTribClow.rep

Bank Sta: Left Right Coeff Contr. Expan.
 -6.5 6.5 .1 .3

Ineffective Flow num= 2
 Sta L Sta R Elev Permanent
 -81 -6.5 658.1 F
 6.5 46.5 658.6 F

Upstream Embankment side slope = 0 horiz. to 1.0 vertical
 Downstream Embankment side slope = 0 horiz. to 1.0 vertical
 Maximum allowable submergence for weir flow = .98
 Elevation at which weir flow begins =
 Energy head used in spillway design =
 Spillway height used in design =
 Weir crest shape = Broad Crested

Number of Culverts = 1

Culvert Name Shape Rise Span
 Culvert #1 Box 6 12
 FHWA Chart # 8 - flared wingwalls
 FHWA Scale # 1 - wingwall flared 30 to 75 deg.
 Solution Criteria = Highest U.S. EG
 Culvert Upstrm Dist Length Top n Bottom n Depth Blocked Entrance Loss Coef
 Exit Loss Coef
 1 1 22 .013 .013 0 .2
 1
 Upstream Elevation = 651.1
 Centerline Station = 0
 Downstream Elevation = 650.8
 Centerline Station = 0

CULVERT OUTPUT Profile #10 Yr Culv Group: Culvert #1

Q Culv Group (cfs)	307.00	Culv Full Len (ft)	
# Barrels	1	Culv Vel US (ft/s)	9.37
Q Barrel (cfs)	307.00	Culv Vel DS (ft/s)	11.60
E.G. US. (ft)	655.47	Culv Inv El Up (ft)	651.10
W.S. US. (ft)	654.72	Culv Inv El Dn (ft)	650.80
E.G. DS (ft)	654.85	Culv Frctn Ls (ft)	0.10
W.S. DS (ft)	653.52	Culv Exit Loss (ft)	0.24
Delta EG (ft)	0.62	Culv Entr Loss (ft)	0.27
Delta WS (ft)	1.20	Q Weir (cfs)	
E.G. IC (ft)	655.42	Weir Sta Lft (ft)	
E.G. OC (ft)	655.47	Weir Sta Rgt (ft)	
Culvert Control	Outlet	Weir Submerg	
Culv WS Inlet (ft)	653.83	Weir Max Depth (ft)	
Culv WS Outlet (ft)	653.01	Weir Avg Depth (ft)	
Culv Nml Depth (ft)	1.63	Weir Flow Area (sq ft)	
Culv Crt Depth (ft)	2.73	Min El Weir Flow (ft)	658.61

Warning: Since the culvert has supercritical flow, the program should be run in mixed flow in order to check if the cross section downstream of the culvert has supercritical flow.

Note: The flow in the culvert is entirely supercritical.

CULVERT OUTPUT Profile #100 Yr Culv Group: Culvert #1

Q Culv Group (cfs)	418.00	Culv Full Len (ft)	
# Barrels	1	Culv Vel US (ft/s)	10.39
Q Barrel (cfs)	418.00	Culv Vel DS (ft/s)	12.61
E.G. US. (ft)	656.46	Culv Inv El Up (ft)	651.10

```

westTribClow.rep
W.S. US. (ft)          655.56   Culv Inv El Dn (ft)      650.80
E.G. DS (ft)          655.77   Culv Frctn Ls (ft)      0.10
W.S. DS (ft)          654.13   Culv Exit Loss (ft)     0.27
Delta EG (ft)         0.70    Culv Entr Loss (ft)     0.34
Delta WS (ft)         1.43    Q Weir (cfs)
E.G. IC (ft)          656.46   Weir Sta Lft (ft)
E.G. OC (ft)          656.46   Weir Sta Rgt (ft)
Culvert Control      Outlet   Weir Submerg
Culv WS Inlet (ft)    654.45   Weir Max Depth (ft)
Culv WS Outlet (ft)   653.56   Weir Avg Depth (ft)
Culv Nml Depth (ft)   1.99    Weir Flow Area (sq ft)
Culv Crt Depth (ft)   3.35    Min El Weir Flow (ft)   658.61

```

Warning: Since the culvert has supercritical flow, the program should be run in mixed flow in order to check if the cross section downstream of the culvert has supercritical flow.

Note: The flow in the culvert is entirely supercritical.

CROSS SECTION

RIVER: WestTribClow
 REACH: WestTribClow RS: 1787

INPUT

Description: Sta: 17+87

Station Elevation Data num= 11

Sta	Elev	Sta	Elev	Sta	Elev	Sta	Elev	Sta	Elev
-81	658.9	-58	658.6	-24	658	-17	657	-6.5	658
-6	650.8	0	650.8	6	650.8	6.5	658	22.5	658
46.5	659								

Manning's n Values num= 3

Sta	n Val	Sta	n Val	Sta	n Val
-81	.08	-6.5	.03	6.5	.08

Bank Sta: Left Right Lengths: Left Channel Right Coeff Contr. Expan.

-6.5	6.5	10	10	10	.1	.3
------	-----	----	----	----	----	----

Ineffective Flow num= 2

Sta L	Sta R	Elev	Permanent
-81	-6.5	658.1	F
6.5	46.5	658.6	F

CROSS SECTION OUTPUT Profile #10 Yr

E.G. Elev (ft)	654.85	Element	Left OB	Channel
Right OB Vel Head (ft)	1.34	wt. n-Val.		0.030
W.S. Elev (ft)	653.52	Reach Len. (ft)	10.00	10.00
10.00 Crit w.s. (ft)	653.52	Flow Area (sq ft)		33.10
E.G. Slope (ft/ft)	0.014925	Area (sq ft)		33.10
Q Total (cfs)	307.00	Flow (cfs)		307.00
Top width (ft)	12.38	Top width (ft)		12.38
Vel Total (ft/s)	9.27	Avg. Vel. (ft/s)		9.27

	westTribClow.rep			
Max Chl Dpth (ft)	2.72	Hydr. Depth (ft)		2.67
Conv. Total (cfs)	2512.9	Conv. (cfs)		2512.9
Length Wtd. (ft)	10.00	wetted Per. (ft)		17.44
Min Ch El (ft)	650.80	Shear (lb/sq ft)		1.77
Alpha	1.00	Stream Power (lb/ft s)	46.50	0.00
0.00				
Frctn Loss (ft)	0.07	Cum Volume (acre-ft)	0.00	1.33
0.00				
C & E Loss (ft)	0.23	Cum SA (acres)	0.00	0.46
0.00				

Warning: The energy equation could not be balanced within the specified number of iterations. The program used critical depth for the water surface and continued on with the calculations.

Warning: The velocity head has changed by more than 0.5 ft (0.15 m). This may indicate the need for additional cross sections.

Warning: The conveyance ratio (upstream conveyance divided by downstream conveyance) is less than 0.7 or greater than 1.4. This may indicate the need for additional cross sections.

Warning: The energy loss was greater than 1.0 ft (0.3 m) between the current and previous cross section. This may indicate the need for additional cross sections.

Warning: During the standard step iterations, when the assumed water surface was set equal to critical depth, the calculated water surface came back below critical depth. This indicates that there is not a valid subcritical answer. The program defaulted to critical depth.

Note: Multiple critical depths were found at this location. The critical depth with the lowest, valid, water surface was used.

CROSS SECTION OUTPUT Profile #100 Yr

		Element	Left OB	Channel
E.G. Elev (ft)	655.77			
Right OB				
Vel Head (ft)	1.63	wt. n-Val.		0.030
w.S. Elev (ft)	654.13	Reach Len. (ft)	10.00	10.00
10.00				
Crit w.S. (ft)	654.13	Flow Area (sq ft)		40.74
E.G. Slope (ft/ft)	0.015166	Area (sq ft)		40.74
Q Total (cfs)	418.00	Flow (cfs)		418.00
Top Width (ft)	12.46	Top Width (ft)		12.46
Vel Total (ft/s)	10.26	Avg. Vel. (ft/s)		10.26
Max Chl Dpth (ft)	3.33	Hydr. Depth (ft)		3.27
Conv. Total (cfs)	3394.2	Conv. (cfs)		3394.2
Length wtd. (ft)	10.00	wetted Per. (ft)		18.68
Min Ch El (ft)	650.80	Shear (lb/sq ft)		2.07

		WestTribClow.rep		
Alpha	1.00	Stream Power (lb/ft s)	46.50	0.00
0.00				
Frctn Loss (ft)	0.07	Cum Volume (acre-ft)	0.00	1.59
0.01				
C & E Loss (ft)	0.27	Cum SA (acres)	0.01	0.50
0.03				

Warning: The energy equation could not be balanced within the specified number of iterations. The program used critical depth for the water surface and continued on with the calculations.

Warning: The velocity head has changed by more than 0.5 ft (0.15 m). This may indicate the need for additional cross sections.

Warning: The conveyance ratio (upstream conveyance divided by downstream conveyance) is less than 0.7 or greater than 1.4. This may indicate the need for additional cross sections.

Warning: The energy loss was greater than 1.0 ft (0.3 m). between the current and previous cross section. This may indicate the need for additional cross sections.

Warning: During the standard step iterations, when the assumed water surface was set equal to critical depth, the calculated water surface came back below critical depth. This indicates that there is not a valid subcritical answer. The program defaulted to critical depth.

Note: Multiple critical depths were found at this location. The critical depth with the lowest, valid, water surface was used.

CROSS SECTION

RIVER: WestTribClow
 REACH: WestTribClow RS: 1777

INPUT

Description: 17+77

Station Elevation Data	num=	22							
Sta Elev Sta Elev Sta Elev Sta Elev Sta Elev									
-55 658 -30 657 -24 656 -18.5 655 -17 654.8									
-15.5 654 -14.5 653 -11.5 652 -7.5 651 -5 650.3									
0 650 2.5 650 6.5 650.4 7.5 651 9 652									
10.5 653 12 654 16.5 654.5 20 655 27 656									
31.5 657 41 658									

Manning's n Values	num=	3
Sta n Val Sta n Val Sta n Val		
-55 .08 -17 .03 12 .08		

Bank Sta: Left Right	Lengths: Left Channel Right	Coeff Contr.	Expan.
-17 12	114 68 87	.1	.3

Ineffective Flow	num=	2
Sta L Sta R Elev Permanent		
-55 -9 658.1 F		
9 41 658.6 F		

CROSS SECTION OUTPUT Profile #10 Yr

E.G. Elev (ft)	653.84	Element	Left OB	Channel
Right OB Vel Head (ft)	0.56	wt. n-val.		0.030
w.s. Elev (ft)	653.28	Reach Len. (ft)	114.00	68.00

westTribClow.rep

87.00				
Crit W.S. (ft)	652.51	Flow Area (sq ft)		51.05
E.G. Slope (ft/ft)	0.003848	Area (sq ft)		58.60
Q Total (cfs)	307.00	Flow (cfs)		307.00
Top Width (ft)	25.69	Top Width (ft)		25.69
Vel Total (ft/s)	6.01	Avg. Vel. (ft/s)		6.01
Max Chl Dpth (ft)	3.28	Hydr. Depth (ft)		2.84
Conv. Total (cfs)	4949.0	Conv. (cfs)		4949.0
Length Wtd. (ft)	68.00	wetted Per. (ft)		18.64
Min Ch El (ft)	650.00	Shear (lb/sq ft)		0.66
Alpha	1.00	Stream Power (lb/ft s)	41.00	0.00
0.00				
Frctn Loss (ft)	0.14	Cum Volume (acre-ft)	0.00	1.32
0.00				
C & E Loss (ft)	0.12	Cum SA (acres)	0.00	0.46
0.00				

Warning: The conveyance ratio (upstream conveyance divided by downstream conveyance) is less than 0.7 or greater than 1.4.

This may indicate the need for additional cross sections.

Note: Multiple critical depths were found at this location. The critical depth with the lowest, valid, energy was used.

CROSS SECTION OUTPUT Profile #100 Yr

E.G. Elev (ft)	654.57	Element	Left OB	Channel
Right OB				
Vel Head (ft)	0.72	wt. n-val.		0.030
W.S. Elev (ft)	653.85	Reach Len. (ft)	114.00	68.00
87.00				
Crit W.S. (ft)	652.99	Flow Area (sq ft)		61.38
E.G. Slope (ft/ft)	0.003860	Area (sq ft)		73.75
Q Total (cfs)	418.00	Flow (cfs)		418.00
Top Width (ft)	27.12	Top Width (ft)		27.12
Vel Total (ft/s)	6.81	Avg. Vel. (ft/s)		6.81
Max Chl Dpth (ft)	3.85	Hydr. Depth (ft)		3.41
Conv. Total (cfs)	6728.2	Conv. (cfs)		6728.2
Length Wtd. (ft)	68.00	wetted Per. (ft)		18.64
Min Ch El (ft)	650.00	Shear (lb/sq ft)		0.79
Alpha	1.00	Stream Power (lb/ft s)	41.00	0.00
0.00				

Frctn Loss (ft)	0.14	westTribCFlow.rep Cum Volume (acre-ft)	0.00	1.58
0.01				
C & E Loss (ft)	0.15	Cum SA (acres)	0.01	0.49
0.03				

Warning: The velocity head has changed by more than 0.5 ft (0.15 m). This may indicate the need for additional cross sections.
Warning: The conveyance ratio (upstream conveyance divided by downstream conveyance) is less than 0.7 or greater than 1.4.
This may indicate the need for additional cross sections.
Note: Multiple critical depths were found at this location. The critical depth with the lowest, valid, energy was used.

CROSS SECTION

RIVER: WestTribCFlow
REACH: WestTribCFlow RS: 1709

INPUT

Description: Sta 17+09

Station Elevation Data	num=	25							
Sta Elev	Sta Elev	Sta Elev	Sta Elev	Sta Elev	Sta Elev	Sta Elev	Sta Elev	Sta Elev	Sta Elev
-127.5 655.1	-124 655	-39 654.1	-10 654.9	-6 654					
-5.5 653	-5 652	-4.5 651	-4 650	0 649.1					
1.5 650	8.5 650.5	10.5 650	14 649.3	17 650					
19.5 651	22 652	24 653	27 654	30 655					
31 655.1	32 655	60 654.3	101 654.6	140.5 654.7					

Manning's n Values	num=	3
Sta n Val	Sta n Val	Sta n Val
-127.5 .08	-10 .03	31 .08

Bank Sta: Left	Right	Lengths: Left	Channel	Right	Coeff	Contr.	Expan.
-10	31	76	82	60	.1	.3	
Ineffective Flow	num=	2					
Sta L Sta R Elev	Permanent						
-127.5 -10 658.1	F						
34 140.5 658.1	F						
Left Levee	Station=	-10	Elevation=	655			
Right Levee	Station=	31	Elevation=	654.5			

CROSS SECTION OUTPUT Profile #10 Yr

E.G. Elev (ft)	653.58	Element	Left OB	Channel
Right OB				
Vel Head (ft)	0.18	wt. n-Val.		0.030
W.S. Elev (ft)	653.41	Reach Len. (ft)	76.00	82.00
60.00				
Crit w.s. (ft)	651.70	Flow Area (sq ft)		91.00
E.G. Slope (ft/ft)	0.001263	Area (sq ft)		91.00
Q Total (cfs)	307.00	Flow (cfs)		307.00
Top width (ft)	30.92	Top width (ft)		30.92
Vel Total (ft/s)	3.37	Avg. Vel. (ft/s)		3.37

	westTribClow.rep			
Max Chl Dpth (ft)	4.31	Hydr. Depth (ft)		2.94
Conv. Total (cfs)	8639.3	Conv. (cfs)		8639.3
Length Wtd. (ft)	82.00	wetted Per. (ft)		34.29
Min Ch El (ft)	649.10	Shear (lb/sq ft)		0.21
Alpha	1.00	Stream Power (lb/ft s)	140.50	-10.00
31.00		Cum Volume (acre-ft)	0.00	1.20
Frctn Loss (ft)	0.10	Cum SA (acres)	0.00	0.42
0.00				
C & E Loss (ft)	0.00			
0.00				

Note: Multiple critical depths were found at this location. The critical depth with the lowest, valid, energy was used.

CROSS SECTION OUTPUT Profile #100 Yr

		Element	Left OB	Channel
E.G. Elev (ft)	654.28			
Right OB				
Vel Head (ft)	0.22	wt. n-val.		0.030
w.s. Elev (ft)	654.06	Reach Len. (ft)	76.00	82.00
60.00		Flow Area (sq ft)		111.95
Crit w.s. (ft)	652.08	Area (sq ft)		111.95
E.G. Slope (ft/ft)	0.001312	Flow (cfs)		418.00
Q Total (cfs)	418.00	Top width (ft)		33.44
Top width (ft)	33.44	Avg. Vel. (ft/s)		3.73
Vel Total (ft/s)	3.73	Hydr. Depth (ft)		3.35
Max Chl Dpth (ft)	4.96	Conv. (cfs)		11540.4
Conv. Total (cfs)	11540.4	wetted Per. (ft)		37.29
Length Wtd. (ft)	82.00	Shear (lb/sq ft)		0.25
Min Ch El (ft)	649.10	Stream Power (lb/ft s)	140.50	-10.00
Alpha	1.00	Cum Volume (acre-ft)	0.00	1.43
31.00		Cum SA (acres)	0.01	0.45
Frctn Loss (ft)	0.11			
0.01				
C & E Loss (ft)	0.00			
0.03				

Note: Multiple critical depths were found at this location. The critical depth with the lowest, valid, energy was used.

CROSS SECTION

RIVER: westTribClow

REACH: WestTribClow RS: 1627

INPUT

Description: Sta 16+27

Station Elevation Data

Sta	Elev	Sta	Elev	Sta	Elev	Sta	Elev	Sta	Elev
-132	654.4	-104	654	-50	653.7	-41	654	-20.5	654.7
-19	654	-16.5	653	-14	652	-11.5	651	-6.5	650
-3.5	649	0	648.9	1	649	9.5	650	10.5	651
11.5	652	13	653	15	654	16.5	654.3	18	654
23	653.5	44	654	62	654.3				

Manning's n Values

Sta	n Val	Sta	n Val	Sta	n Val
-132	.08	-19	.03	15	.08

Bank Sta: Left Right Lengths: Left Channel Right Coeff Contr. Expan.
 -19 15 147 127 147 .1 .3

Ineffective Flow num= 2
 Sta L Sta R Elev Permanent
 -132 -20.5 658.1 F
 55 62 658.6 F

Left Levee Station= -20.5 Elevation= 654.8
 Right Levee Station= 16.5 Elevation= 654.3

CROSS SECTION OUTPUT Profile #10 Yr

E.G. Elev (ft)	653.48	Element	Left OB	Channel
Right OB Vel Head (ft)	0.18	wt. n-val.		0.030
W.S. Elev (ft)	653.30	Reach Len. (ft)	147.00	127.00
147.00 Crit w.s. (ft)	651.51	Flow Area (sq ft)		89.67
E.G. slope (ft/ft)	0.001250	Area (sq ft)		89.67
Q Total (cfs)	307.00	Flow (cfs)		307.00
Top width (ft)	30.83	Top width (ft)		30.83
Vel Total (ft/s)	3.42	Avg. vel. (ft/s)		3.42
Max Chl Dpth (ft)	4.40	Hydr. Depth (ft)		2.91
Conv. Total (cfs)	8682.9	Conv. (cfs)		8682.9
Length Wtd. (ft)	127.00	wetted Per. (ft)		32.80
Min Ch El (ft)	648.90	Shear (lb/sq ft)		0.21
Alpha	1.00	Stream Power (lb/ft s)	62.00	-20.50
16.50 Frctn Loss (ft)	0.19	Cum volume (acre-ft)	0.00	1.03
0.00 C & E Loss (ft)	0.01	Cum SA (acres)	0.00	0.36
0.00				

Note: Multiple critical depths were found at this location. The critical depth with the lowest, valid, energy was used.

WestTribClow.rep

CROSS SECTION OUTPUT Profile #100 Yr

E.G. Elev (ft)	654.17	Element	Left OB	Channel
Right OB				
Vel Head (ft)	0.22	wt. n-Val.		0.030
W.S. Elev (ft)	653.95	Reach Len. (ft)	147.00	127.00
147.00				
Crit W.S. (ft)	651.93	Flow Area (sq ft)		110.64
E.G. slope (ft/ft)	0.001302	Area (sq ft)		110.64
Q Total (cfs)	418.00	Flow (cfs)		418.00
Top width (ft)	33.76	Top width (ft)		33.76
vel Total (ft/s)	3.78	Avg. vel. (ft/s)		3.78
Max Chl Dpth (ft)	5.05	Hydr. Depth (ft)		3.28
Conv. Total (cfs)	11583.5	Conv. (cfs)		11583.5
Length wtd. (ft)	127.02	wetted Per. (ft)		36.00
Min Ch El (ft)	648.90	Shear (lb/sq ft)		0.25
Alpha	1.00	Stream Power (lb/ft s)	62.00	-20.50
16.50				
Frctn Loss (ft)	0.19	Cum volume (acre-ft)	0.00	1.22
0.01				
C & E Loss (ft)	0.01	Cum SA (acres)	0.01	0.38
0.03				

Note: Multiple critical depths were found at this location. The critical depth with the lowest, valid, energy was used.

CROSS SECTION

RIVER: WestTribClow
 REACH: WestTribClow RS: 1500

INPUT

Description: Sta: 15+00

Station		Elevation		Data		num= 25			
Sta	Elev	Sta	Elev	Sta	Elev	Sta	Elev	Sta	Elev
-221	654	-170.5	653.4	-132.5	653.8	-92.5	653.6	-55	653.1
-12.7	653.9	-11.7	653	-7.5	650	-6	649.2	0	648.5
4.5	649.2	8	650	9.5	651	13	653	22	654
28.5	655.8	36	654	39.5	653.2	45.5	653	59.5	652.8
74	653	108.5	653.4	134	653.4	161	653.7	173	654

Manning's n Values		num= 3	
Sta	n Val	Sta	n Val
-221	.08	-11.7	.03
		13	.08

Bank Sta:	Left	Right	Lengths:	Left	Channel	Right	Coeff	Contr.	Expan.
	-11.7	13		148	150	142		.1	.3
Ineffective Flow		num=	2						

WestTribClow.rep

Sta L	Sta R	Elev	Permanent		
-221	-12.7	658.1	F		
87	173	658.6	F		
Left Levee	Station=	-12.7	Elevation=	653.9	
Right Levee	Station=	28.5	Elevation=	654	

CROSS SECTION OUTPUT Profile #10 Yr

E.G. Elev (ft)	653.28	Element	Left OB	Channel
Right OB				
Vel Head (ft)	0.26	wt. n-val.	0.000	0.030
0.000				
W.S. Elev (ft)	653.02	Reach Len. (ft)	148.00	150.00
142.00				
Crit w.s. (ft)	651.40	Flow Area (sq ft)	0.00	74.63
0.00				
E.G. Slope (ft/ft)	0.001768	Area (sq ft)	0.00	74.63
0.00				
Q Total (cfs)	307.00	Flow (cfs)	0.00	307.00
0.00				
Top width (ft)	24.90	Top width (ft)	0.02	24.70
0.18				
Vel Total (ft/s)	4.11	Avg. Vel. (ft/s)	0.03	4.11
0.04				
Max Chl Dpth (ft)	4.52	Hydr. Depth (ft)	0.01	3.02
0.01				
Conv. Total (cfs)	7301.2	Conv. (cfs)	0.0	7301.2
0.0				
Length wtd. (ft)	150.00	wetted Per. (ft)	0.03	26.88
0.18				
Min Ch El (ft)	648.50	Shear (lb/sq ft)		0.31
Alpha	1.00	Stream Power (lb/ft s)	173.00	-12.70
28.50				
Frctn Loss (ft)	0.27	Cum Volume (acre-ft)	0.00	0.79
0.00				
C & E Loss (ft)	0.00	Cum SA (acres)	0.00	0.28
0.00				

Note: Multiple critical depths were found at this location. The critical depth with the lowest, valid, energy was used.

CROSS SECTION OUTPUT Profile #100 Yr

E.G. Elev (ft)	653.96	Element	Left OB	Channel
Right OB				
Vel Head (ft)	0.34	wt. n-val.	0.080	0.030
0.080				
W.S. Elev (ft)	653.63	Reach Len. (ft)	148.00	150.00
142.00				
Crit w.s. (ft)	651.89	Flow Area (sq ft)	0.22	89.65
1.78				
E.G. Slope (ft/ft)	0.001773	Area (sq ft)	0.22	89.65
1.78				
Q Total (cfs)	418.00	Flow (cfs)	0.07	417.30
0.64				
Top width (ft)	31.05	Top width (ft)	0.70	24.70
5.66				
Vel Total (ft/s)	4.56	Avg. Vel. (ft/s)	0.30	4.65

westTribClow.rep

0.36					
Max Chl Dpth (ft)	5.13	Hydr. Depth (ft)	0.31	3.63	
0.31					
Conv. Total (cfs)	9928.0	Conv. (cfs)	1.5	9911.3	
15.2					
Length wtd. (ft)	149.99	wetted Per. (ft)	0.94	26.88	
5.69					
Min Ch El (ft)	648.50	Shear (lb/sq ft)	0.03	0.37	
0.03					
Alpha	1.04	Stream Power (lb/ft s)	173.00	-12.70	
28.50					
Frctn Loss (ft)	0.29	Cum Volume (acre-ft)	0.00	0.93	
0.00					
C & E Loss (ft)	0.00	Cum SA (acres)	0.01	0.30	
0.02					

Note: Multiple critical depths were found at this location. The critical depth with the lowest, valid, energy was used.

CROSS SECTION

RIVER: westTribClow
 REACH: westTribClow RS: 1350

INPUT

Description: Sta 13+50

Station Elevation Data num= 27

Sta	Elev	Sta	Elev	Sta	Elev	Sta	Elev	Sta	Elev
-172.5	654	-156	653.8	-108	653.2	-97.5	653	-84.5	652.7
-57	652.9	-31	653	-17	653.4	-15	653	-13	652
-11	651	-9	650	-5	649	0	648.2	4	648.1
5.5	649	6.5	650	8	651	9	652	10.5	653
11	653.4	26.5	653	41	652.6	61	653	71.5	653.2
113.5	653.7	147.5	654						

Manning's n Values num= 3

Sta	n Val	Sta	n Val	Sta	n Val
-172.5	.08	-17	.03	11	.08

Bank Sta: Left Right Lengths: Left Channel Right Coeff Contr. Expan.

-17	11	134	150	128	.1	.3
-----	----	-----	-----	-----	----	----

Ineffective Flow num= 2

Sta L	Sta R	Elev	Permanent
-172.5	-23	658.1	F
125	147.5	658.6	F

Left Levee Station= -17 Elevation= 653.4
 Right Levee Station= 11 Elevation= 653.5

CROSS SECTION OUTPUT Profile #10 Yr

E.G. Elev (ft)	653.01	Element	Left OB	Channel
Right OB				
Vel Head (ft)	0.27	wt. n-val.		0.030
W.S. Elev (ft)	652.75	Reach Len. (ft)	134.00	150.00
128.00				
Crit w.s. (ft)	651.11	Flow Area (sq ft)		74.29
E.G. slope (ft/ft)	0.001811	Area (sq ft)		74.29

westTribClow.rep

Q Total (cfs)	307.00	Flow (cfs)		307.00
Top width (ft)	24.62	Top width (ft)		24.62
Vel Total (ft/s)	4.13	Avg. Vel. (ft/s)		4.13
Max Chl Dpth (ft)	4.65	Hydr. Depth (ft)		3.02
Conv. Total (cfs)	7213.5	Conv. (cfs)		7213.5
Length wtd. (ft)	150.00	wetted Per. (ft)		27.07
Min Ch El (ft)	648.10	Shear (lb/sq ft)		0.31
Alpha 11.00	1.00	Stream Power (lb/ft s)	147.50	-17.00
Frctn Loss (ft)	0.35	Cum Volume (acre-ft)		0.53
C & E Loss (ft)	0.01	Cum SA (acres)		0.19

Note: Multiple critical depths were found at this location. The critical depth with the lowest, valid, energy was used.

CROSS SECTION OUTPUT Profile #100 Yr

E.G. Elev (ft)	653.68	Element	Left OB	Channel
Right OB Vel Head (ft)	0.34	wt. n-val.		0.030
W.S. Elev (ft)	653.34	Reach Len. (ft)	134.00	150.00
128.00 Crit W.S. (ft)	651.60	Flow Area (sq ft)		89.51
E.G. Slope (ft/ft)	0.002100	Area (sq ft)		89.51
Q Total (cfs)	418.00	Flow (cfs)		418.00
Top width (ft)	27.60	Top width (ft)		27.60
Vel Total (ft/s)	4.67	Avg. Vel. (ft/s)		4.67
Max Chl Dpth (ft)	5.24	Hydr. Depth (ft)		3.24
Conv. Total (cfs)	9120.7	Conv. (cfs)		9120.7
Length wtd. (ft)	150.00	wetted Per. (ft)		30.33
Min Ch El (ft)	648.10	Shear (lb/sq ft)		0.39
Alpha 11.00	1.00	Stream Power (lb/ft s)	147.50	-17.00
Frctn Loss (ft)	0.40	Cum Volume (acre-ft)	0.00	0.62
0.00 C & E Loss (ft)	0.02	Cum SA (acres)	0.01	0.21
0.01				

Note: Multiple critical depths were found at this location. The critical depth with the lowest, valid, energy was used.

CROSS SECTION

RIVER: WestTribClow
 REACH: WestTribClow RS: 1200

INPUT

Description: Sta 12+00

Station Elevation Data		num= 25		Sta Elev		Sta Elev		Sta Elev		Sta Elev	
Sta	Elev	Sta	Elev	Sta	Elev	Sta	Elev	Sta	Elev	Sta	Elev
-211	654	-158.5	653.5	-97	653	-52	652.1	-18.5	652.7		
-16.5	653	-13.5	653.7	-9.5	653	-8.5	652	-7.5	651		
-5	650	-3	649	0	648	2	648	5	649		
11	650	12	651	14	652	16	653	21	653.1		
25.5	653	56	652.7	100	653	125.5	653.2	154.5	654		

Manning's n Values		num= 3		Sta n Val	
Sta	n Val	Sta	n Val	Sta	n Val
-211	.08	-9.5	.03	16	.08

Bank Sta:	Left	Right	Lengths:	Left Channel	Right	Coeff Contr.	Expan.
	-9.5	16		112	100	.1	.3
Ineffective Flow	num= 1		Permanent				
Sta L	Sta R	Elev	F				
-211	-61	658.1	F				
Left Levee	Station=	-13.5	Elevation=	652.8			
Right Levee	Station=	21	Elevation=	652.8			

CROSS SECTION OUTPUT Profile #10 Yr

E.G. Elev (ft)	652.66	Element	Left OB	Channel
Right OB				
Vel Head (ft)	0.38	wt. n-val.		0.030
w.s. Elev (ft)	652.28	Reach Len. (ft)	112.00	100.00
97.00				
Crit w.s. (ft)	651.21	Flow Area (sq ft)		62.14
E.G. slope (ft/ft)	0.003021	Area (sq ft)		62.14
Q Total (cfs)	307.00	Flow (cfs)		307.00
Top width (ft)	23.34	Top width (ft)		23.34
Vel Total (ft/s)	4.94	Avg. vel. (ft/s)		4.94
Max Chl Dpth (ft)	4.28	Hydr. Depth (ft)		2.66
Conv. Total (cfs)	5585.7	Conv. (cfs)		5585.7
Length Wtd. (ft)	100.00	wetted Per. (ft)		25.42
Min Ch El (ft)	648.00	Shear (lb/sq ft)		0.46
Alpha	1.00	Stream Power (lb/ft s)	154.50	-13.50
21.00				
Frctn Loss (ft)	0.29	Cum volume (acre-ft)		0.30
C & E Loss (ft)	0.00	Cum SA (acres)		0.11

westTribClow.rep

4.5	648	8	649	10	650	12	651	14	652
16	653	18	653.4	19.5	653	20.5	652.7	24	653
38	653	43	652.4	61	652	62.5	651.8	64	652
90.5	652.5	141	652.6	150	653				

Manning's n Values	num=	3
Sta n Val	Sta n Val	Sta n Val
-292 .08	-9.5 .03	16 .08

Bank Sta: Left	Right	Lengths: Left	Channel	Right	Coeff	Contr.	Expan.
-9.5	16	112	100	97	.1	.3	
Ineffective Flow	num=	2					
Sta L Sta R Elev	Permanent						
-292 -86 658.1	F						
188 150 658.6	F						
Left Levee	Station=	-9.5	Elevation=	652.5			
Right Levee	Station=	18	Elevation=	652.8			

CROSS SECTION OUTPUT Profile #10 Yr

E.G. Elev (ft)	652.37	Element	Left OB	Channel
Right OB				
Vel Head (ft)	0.36	wt. n-val.		0.030
w.s. Elev (ft)	652.00	Reach Len. (ft)	112.00	100.00
97.00				
Crit w.s. (ft)	650.72	Flow Area (sq ft)		63.43
E.G. Slope (ft/ft)	0.002713	Area (sq ft)		63.43
Q Total (cfs)	307.00	Flow (cfs)		307.00
Top width (ft)	22.51	Top width (ft)		22.51
Vel Total (ft/s)	4.84	Avg. Vel. (ft/s)		4.84
Max Chl Dpth (ft)	4.60	Hydr. Depth (ft)		2.82
Conv. Total (cfs)	5893.9	Conv. (cfs)		5893.9
Length wtd. (ft)	100.00	wetted Per. (ft)		24.68
Min Ch El (ft)	647.40	Shear (lb/sq ft)		0.44
Alpha	1.00	Stream Power (lb/ft s)	150.00	-9.50
18.00				
Frctn Loss (ft)	0.26	Cum Volume (acre-ft)		0.16
C & E Loss (ft)	0.02	Cum SA (acres)		0.06

Note: Multiple critical depths were found at this location. The critical depth with the lowest, valid, energy was used.

CROSS SECTION OUTPUT Profile #100 Yr

E.G. Elev (ft)	652.91	Element	Left OB	Channel
Right OB				
Vel Head (ft)	0.52	wt. n-val.		0.030

WestTribClow.rep

W.S. Elev (ft)	652.40	Reach Len. (ft)	112.00	100.00
97.00				
Crit w.s. (ft)	651.26	Flow Area (sq ft)		72.53
E.G. Slope (ft/ft)	0.003504	Area (sq ft)		72.53
Q Total (cfs)	418.00	Flow (cfs)		418.00
Top width (ft)	23.95	Top width (ft)		23.95
Vel Total (ft/s)	5.76	Avg. Vel. (ft/s)		5.76
Max chl Dpth (ft)	5.00	Hydr. Depth (ft)		3.03
Conv. Total (cfs)	7061.0	conv. (cfs)		7061.0
Length wtd. (ft)	100.00	wetted Per. (ft)		26.32
Min ch El (ft)	647.40	Shear (lb/sq ft)		0.60
Alpha	1.00	Stream Power (lb/ft s)	150.00	-9.50
18.00				
Frctn Loss (ft)	0.35	Cum Volume (acre-ft)	0.00	0.18
0.00				
C & E Loss (ft)	0.02	Cum SA (acres)	0.01	0.06
0.01				

Note: Multiple critical depths were found at this location. The critical depth with the lowest, valid, energy was used.

CROSS SECTION

RIVER: WestTribClow
 REACH: WestTribClow RS: 1000

INPUT

Description: Sta 10+00

Station Elevation Data		num=	27						
Sta	Elev	Sta	Elev	Sta	Elev	Sta	Elev	Sta	Elev
-220.5	653	-166.5	652.7	-85.5	652	-47.5	651.1	-22	652
-18	652.1	-15	652	-11	652	-10	651	-9.5	650
-8	648	-2	647	0	646.2	2	647	3.5	648
6.5	650	8	651	18	652	28	652.1	35	652
44	651.5	54	652	59	652.1	65.5	652	73.5	651.5
79	652	92	653						

Manning's n Values		num=	3
Sta	n Val	Sta	n Val
-220.5	.08	-11	.03
		18	.08

Bank Sta: Left	Right	Lengths: Left	Channel	Right	Coeff	Contr.	Expan.
	-11	18	0	0	.1	.3	

Ineffective Flow	num=	1
Sta L	Sta R	Elev
-220.5	-111	F
Left Levee	Station=	-18
Right Levee	Station=	28
	Elevation=	652.1
	Elevation=	652.1

CROSS SECTION OUTPUT Profile #10 Yr

westTribClow.rep

E.G. Elev (ft)	652.09	Element	Left OB	Channel
Right OB Vel Head (ft)	0.29	wt. n-val.		0.030
W.S. Elev (ft)	651.80	Reach Len. (ft)		
Crit w.s. (ft)	649.96	Flow Area (sq ft)		71.77
E.G. slope (ft/ft)	0.002418	Area (sq ft)		71.77
Q Total (cfs)	310.00	Flow (cfs)		310.00
Top width (ft)	26.80	Top width (ft)		26.80
Vel Total (ft/s)	4.32	Avg. Vel. (ft/s)		4.32
Max chl Dpth (ft)	5.60	Hydr. Depth (ft)		2.68
Conv. Total (cfs)	6303.9	Conv. (cfs)		6303.9
Length wtd. (ft)		wetted Per. (ft)		30.39
Min ch El (ft)	646.20	Shear (lb/sq ft)		0.36
Alpha 28.00	1.00	Stream Power (lb/ft s)	92.00	-18.00
Frctn Loss (ft)		Cum Volume (acre-ft)		
C & E Loss (ft)		Cum SA (acres)		

Note: Multiple critical depths were found at this location. The critical depth with the lowest, valid, energy was used.

CROSS SECTION OUTPUT Profile #100 Yr

E.G. Elev (ft)	652.54	Element	Left OB	Channel
Right OB Vel Head (ft)	0.44	wt. n-val.	0.080	0.030
0.080 W.S. Elev (ft)	652.10	Reach Len. (ft)		
Crit w.s. (ft)	650.55	Flow Area (sq ft)	0.55	80.25
0.50 E.G. slope (ft/ft)	0.003481	Area (sq ft)	0.55	80.25
0.50 Q Total (cfs)	427.00	Flow (cfs)	0.11	426.82
0.07 Top width (ft)	46.00	Top width (ft)	7.00	29.00
10.00 Vel Total (ft/s)	5.25	Avg. Vel. (ft/s)	0.20	5.32
0.15 Max chl Dpth (ft)	5.90	Hydr. Depth (ft)	0.08	2.77
0.05 Conv. Total (cfs)	7237.2	Conv. (cfs)	1.9	7234.1
1.3 Length wtd. (ft)		wetted Per. (ft)	7.00	32.68
10.00				

Min Ch El (ft)	646.20	westTribClow.rep Shear (lb/sq ft)	0.02	0.53
0.01				
Alpha	1.03	Stream Power (lb/ft s)	92.00	-18.00
28.00				
Frctn Loss (ft)		Cum volume (acre-ft)		
C & E Loss (ft)		Cum SA (acres)		

Note: Multiple critical depths were found at this location. The critical depth with the lowest, valid, energy was used.

SUMMARY OF MANNING'S N VALUES

River: westTribClow

Reach	River Sta.	n1	n2	n3
westTribClow	1811	.08	.03	.08
westTribClow	1800	culvert		
westTribClow	1787	.08	.03	.08
westTribClow	1777	.08	.03	.08
westTribClow	1709	.08	.03	.08
westTribClow	1627	.08	.03	.08
westTribClow	1500	.08	.03	.08
westTribClow	1350	.08	.03	.08
westTribClow	1200	.08	.03	.08
westTribClow	1100	.08	.03	.08
westTribClow	1000	.08	.03	.08

SUMMARY OF REACH LENGTHS

River: westTribClow

Reach	River Sta.	Left	Channel	Right
westTribClow	1811	34	34	34
westTribClow	1800	culvert		
westTribClow	1787	10	10	10
westTribClow	1777	114	68	87
westTribClow	1709	76	82	60
westTribClow	1627	147	127	147
westTribClow	1500	148	150	142
westTribClow	1350	134	150	128
westTribClow	1200	112	100	97
westTribClow	1100	112	100	97
westTribClow	1000	0	0	0

SUMMARY OF CONTRACTION AND EXPANSION COEFFICIENTS

River: westTribClow

Reach	River Sta.	Contr.	Expan.
-------	------------	--------	--------

westTribClow.rep

westTribClow	1811	.1	.3
westTribClow	1800	Culvert	
westTribClow	1787	.1	.3
westTribClow	1777	.1	.3
westTribClow	1709	.1	.3
westTribClow	1627	.1	.3
westTribClow	1500	.1	.3
westTribClow	1350	.1	.3
westTribClow	1200	.1	.3
westTribClow	1100	.1	.3
westTribClow	1000	.1	.3

HEC-RAS Plan: MODEXIST River: WestTribClow Reach: WestTribClow

Reach	River Sta	Profile	Q Total (cfs)	Min Ch El (ft)	W.S. Elev (ft)	Crit W.S. (ft)	E.G. Elev (ft)	E.G. Slope (ft/ft)	Vel Chnl (ft/s)	Flow Area (sq ft)	Top Width (ft)	Froude # Chl
WestTribClow	1811	PF 1	10.00	651.10	651.45	651.38	651.54	0.010049	2.38	4.21	12.05	0.71
WestTribClow	1811	PF 2	20.00	651.10	651.68	651.55	651.81	0.007876	2.87	6.96	12.08	0.67
WestTribClow	1811	PF 3	30.00	651.10	651.86	651.68	652.03	0.007423	3.29	9.13	12.11	0.67
WestTribClow	1811	PF 4	40.00	651.10	652.02	651.80	652.22	0.007140	3.61	11.08	12.13	0.67
WestTribClow	1811	PF 5	50.00	651.10	652.17	651.91	652.40	0.006954	3.88	12.88	12.15	0.66
WestTribClow	1811	PF 6	60.00	651.10	652.31	652.01	652.57	0.006823	4.12	14.57	12.17	0.66
WestTribClow	1811	PF 7	70.00	651.10	652.44	652.12	652.73	0.006718	4.33	16.17	12.19	0.66
WestTribClow	1811	PF 8	80.00	651.10	652.56	652.21	652.88	0.006643	4.52	17.69	12.21	0.66
WestTribClow	1811	PF 9	90.00	651.10	652.68	652.30	653.02	0.006584	4.70	19.16	12.23	0.66
WestTribClow	1811	PF 10	100.00	651.10	652.80	652.38	653.16	0.006537	4.86	20.58	12.25	0.66
WestTribClow	1811	PF 11	125.00	651.10	653.07	652.60	653.50	0.006452	5.22	23.96	12.29	0.66
WestTribClow	1811	PF 12	150.00	651.10	653.33	652.79	653.81	0.006406	5.53	27.13	12.32	0.66
WestTribClow	1811	PF 13	175.00	651.10	653.57	652.97	654.10	0.006383	5.81	30.14	12.36	0.66
WestTribClow	1811	PF 14	200.00	651.10	653.81	653.14	654.38	0.006373	6.06	33.03	12.39	0.65
WestTribClow	1811	PF 15	225.00	651.10	654.03	653.31	654.65	0.006373	6.28	35.81	12.43	0.65
WestTribClow	1811	PF 16	250.00	651.10	654.25	653.46	654.90	0.006381	6.49	38.50	12.46	0.65
WestTribClow	1811	PF 17	275.00	651.10	654.46	653.63	655.15	0.006390	6.69	41.12	12.49	0.65
WestTribClow	1811	PF 18	300.00	651.10	654.66	653.77	655.40	0.006408	6.87	43.67	12.52	0.65
WestTribClow	1811	PF 19	325.00	651.10	654.86	653.93	655.63	0.006425	7.04	46.16	12.55	0.65
WestTribClow	1811	PF 20	350.00	651.10	655.05	654.06	655.86	0.006447	7.20	48.59	12.57	0.65
WestTribClow	1811	PF 21	375.00	651.10	655.24	654.20	656.08	0.006469	7.36	50.97	12.60	0.64
WestTribClow	1811	PF 22	400.00	651.10	655.43	654.34	656.30	0.006493	7.50	53.31	12.63	0.64
WestTribClow	1811	PF 23	425.00	651.10	655.61	654.47	656.52	0.006517	7.64	55.61	12.65	0.64
WestTribClow	1811	PF 24	450.00	651.10	655.80	654.57	656.73	0.006511	7.76	57.98	12.68	0.64
WestTribClow	1811	PF 25	475.00	651.10	655.99	654.72	656.95	0.006476	7.86	60.41	12.71	0.64
WestTribClow	1811	PF 26	500.00	651.10	656.18	654.86	657.16	0.006447	7.96	62.82	12.74	0.63
WestTribClow	1811	PF 27	525.00	651.10	656.37	654.98	657.37	0.006422	8.05	65.19	12.76	0.63
WestTribClow	1811	PF 28	550.00	651.10	656.55	655.10	657.58	0.006400	8.14	67.54	12.79	0.62
WestTribClow	1811	PF 29	575.00	651.10	656.73	655.22	657.78	0.006381	8.23	69.87	12.82	0.62
WestTribClow	1811	PF 30	600.00	651.10	656.91	655.33	657.98	0.006364	8.31	72.17	12.84	0.62
WestTribClow	1800		Culvert									
WestTribClow	1787	PF 1	10.00	650.80	651.08	651.08	651.22	0.021145	2.98	3.35	12.04	1.00
WestTribClow	1787	PF 2	20.00	650.80	651.24	651.24	651.46	0.018851	3.77	5.31	12.06	1.00
WestTribClow	1787	PF 3	30.00	650.80	651.37	651.37	651.67	0.018041	4.34	6.92	12.08	1.01
WestTribClow	1787	PF 4	40.00	650.80	651.50	651.50	651.85	0.016988	4.74	8.44	12.10	1.00
WestTribClow	1787	PF 5	50.00	650.80	651.61	651.61	652.02	0.016578	5.11	9.78	12.11	1.00
WestTribClow	1787	PF 6	60.00	650.80	651.72	651.72	652.17	0.016136	5.42	11.07	12.13	1.00
WestTribClow	1787	PF 7	70.00	650.80	651.82	651.82	652.32	0.015635	5.68	12.33	12.14	0.99
WestTribClow	1787	PF 8	80.00	650.80	651.92	651.92	652.46	0.015267	5.91	13.53	12.16	0.99
WestTribClow	1787	PF 9	90.00	650.80	652.00	652.00	652.60	0.015528	6.20	14.51	12.17	1.00
WestTribClow	1787	PF 10	100.00	650.80	652.09	652.09	652.73	0.015278	6.41	15.61	12.18	1.00
WestTribClow	1787	PF 11	125.00	650.80	652.30	652.30	653.04	0.015078	6.90	18.12	12.21	1.00
WestTribClow	1787	PF 12	150.00	650.80	652.49	652.49	653.32	0.015004	7.33	20.45	12.23	1.00
WestTribClow	1787	PF 13	175.00	650.80	652.67	652.67	653.59	0.014833	7.70	22.73	12.26	1.00
WestTribClow	1787	PF 14	200.00	650.80	652.84	652.84	653.85	0.015015	8.09	24.73	12.28	1.00
WestTribClow	1787	PF 15	225.00	650.80	653.01	653.01	654.10	0.014780	8.36	26.90	12.31	1.00
WestTribClow	1787	PF 16	250.00	650.80	653.16	653.16	654.34	0.015043	8.71	28.71	12.33	1.01
WestTribClow	1787	PF 17	275.00	650.80	653.31	653.31	654.57	0.015096	8.99	30.59	12.35	1.01
WestTribClow	1787	PF 18	300.00	650.80	653.48	653.48	654.79	0.014832	9.19	32.65	12.37	1.00
WestTribClow	1787	PF 19	325.00	650.80	653.62	653.62	655.01	0.015015	9.46	34.35	12.39	1.00
WestTribClow	1787	PF 20	350.00	650.80	653.76	653.76	655.22	0.015059	9.69	36.11	12.41	1.00
WestTribClow	1787	PF 21	375.00	650.80	653.90	653.90	655.42	0.015129	9.92	37.81	12.43	1.00
WestTribClow	1787	PF 22	400.00	650.80	654.04	654.04	655.62	0.015051	10.10	39.62	12.45	1.00
WestTribClow	1787	PF 23	425.00	650.80	654.16	654.16	655.82	0.015256	10.33	41.13	12.47	1.00
WestTribClow	1787	PF 24	450.00	650.80	654.30	654.30	656.01	0.015205	10.50	42.86	12.49	1.00
WestTribClow	1787	PF 25	475.00	650.80	654.43	654.43	656.20	0.015248	10.68	44.48	12.50	1.00
WestTribClow	1787	PF 26	500.00	650.80	654.56	654.56	656.39	0.015267	10.85	46.10	12.52	1.00
WestTribClow	1787	PF 27	525.00	650.80	654.68	654.68	656.57	0.015370	11.03	47.60	12.54	1.00
WestTribClow	1787	PF 28	550.00	650.80	654.79	654.79	656.75	0.015589	11.23	48.96	12.55	1.00
WestTribClow	1787	PF 29	575.00	650.80	654.91	654.91	656.92	0.015661	11.40	50.45	12.57	1.00
WestTribClow	1787	PF 30	600.00	650.80	655.02	655.02	657.10	0.015719	11.55	51.94	12.59	1.00
WestTribClow	1777	PF 1	10.00	650.00	650.50	650.42	650.59	0.009080	2.32	4.31	12.39	0.69
WestTribClow	1777	PF 2	20.00	650.00	650.70	650.59	650.83	0.008748	2.93	6.83	13.42	0.72
WestTribClow	1777	PF 3	30.00	650.00	650.84	650.72	651.02	0.009246	3.42	8.76	14.15	0.77
WestTribClow	1777	PF 4	40.00	650.00	650.94	650.85	651.18	0.010505	3.93	10.17	14.66	0.83
WestTribClow	1777	PF 5	50.00	650.00	651.04	650.95	651.32	0.010834	4.27	11.70	15.21	0.86
WestTribClow	1777	PF 6	60.00	650.00	651.15	651.06	651.46	0.010457	4.47	13.42	15.82	0.86
WestTribClow	1777	PF 7	70.00	650.00	651.26	651.15	651.59	0.009828	4.59	15.24	16.44	0.84
WestTribClow	1777	PF 8	80.00	650.00	651.37	651.24	651.71	0.009203	4.68	17.10	17.05	0.82
WestTribClow	1777	PF 9	90.00	650.00	651.48	651.32	651.83	0.008432	4.76	18.93	17.64	0.80
WestTribClow	1777	PF 10	100.00	650.00	651.58	651.40	651.95	0.007793	4.82	20.73	18.21	0.78
WestTribClow	1777	PF 11	125.00	650.00	651.83	651.57	652.22	0.006664	4.98	25.09	19.57	0.74
WestTribClow	1777	PF 12	150.00	650.00	652.06	651.72	652.47	0.005910	5.14	29.20	20.78	0.71

HEC-RAS Plan: MODEXIST River: WestTribClow Reach: WestTribClow (Continued)

Reach	River Sta	Profile	Q Total (cfs)	Min Ch El (ft)	W.S. Elev (ft)	Crit W.S. (ft)	E.G. Elev (ft)	E.G. Slope (ft/ft)	Vel Chnl (ft/s)	Flow Area (sq ft)	Top Width (ft)	Froude # Chl
WestTribClow	1777	PF 13	175.00	650.00	652.27	651.87	652.71	0.005340	5.30	33.02	21.73	0.69
WestTribClow	1777	PF 14	200.00	650.00	652.47	652.00	652.94	0.004958	5.47	36.58	22.62	0.68
WestTribClow	1777	PF 15	225.00	650.00	652.66	652.13	653.15	0.004687	5.63	39.93	23.46	0.67
WestTribClow	1777	PF 16	250.00	650.00	652.83	652.26	653.36	0.004490	5.80	43.09	24.25	0.66
WestTribClow	1777	PF 17	275.00	650.00	653.00	652.37	653.55	0.004342	5.97	46.08	25.00	0.66
WestTribClow	1777	PF 18	300.00	650.00	653.16	652.49	653.74	0.004229	6.13	48.94	25.40	0.66
WestTribClow	1777	PF 19	325.00	650.00	653.31	652.60	653.92	0.004151	6.29	51.63	25.77	0.65
WestTribClow	1777	PF 20	350.00	650.00	653.45	652.72	654.10	0.004115	6.47	54.12	26.12	0.66
WestTribClow	1777	PF 21	375.00	650.00	653.58	652.82	654.26	0.004092	6.64	56.51	26.45	0.66
WestTribClow	1777	PF 22	400.00	650.00	653.71	652.92	654.43	0.004060	6.79	58.88	26.78	0.66
WestTribClow	1777	PF 23	425.00	650.00	653.84	653.03	654.59	0.004038	6.95	61.15	27.09	0.66
WestTribClow	1777	PF 24	450.00	650.00	653.96	653.12	654.74	0.004036	7.11	63.30	27.39	0.67
WestTribClow	1777	PF 25	475.00	650.00	654.03	653.22	654.87	0.004191	7.35	64.65	27.84	0.68
WestTribClow	1777	PF 26	500.00	650.00	654.09	653.32	654.99	0.004392	7.61	65.74	28.50	0.70
WestTribClow	1777	PF 27	525.00	650.00	654.15	653.41	655.11	0.004589	7.86	66.81	29.14	0.72
WestTribClow	1777	PF 28	550.00	650.00	654.11	653.51	655.19	0.005235	8.33	66.04	28.67	0.77
WestTribClow	1777	PF 29	575.00	650.00	654.14	653.61	655.30	0.005543	8.62	66.67	29.06	0.79
WestTribClow	1777	PF 30	600.00	650.00	654.17	653.69	655.41	0.005871	8.93	67.22	29.39	0.81
WestTribClow	1709	PF 1	10.00	649.10	650.01	649.85	650.07	0.006357	2.08	4.81	12.11	0.58
WestTribClow	1709	PF 2	20.00	649.10	650.29	650.06	650.37	0.005103	2.18	9.17	18.15	0.54
WestTribClow	1709	PF 3	30.00	649.10	650.51	650.20	650.59	0.004120	2.21	13.60	22.53	0.50
WestTribClow	1709	PF 4	40.00	649.10	650.69	650.32	650.77	0.003169	2.26	17.68	23.07	0.46
WestTribClow	1709	PF 5	50.00	649.10	650.86	650.43	650.94	0.002629	2.31	21.61	23.57	0.43
WestTribClow	1709	PF 6	60.00	649.10	651.02	650.51	651.10	0.002288	2.36	25.37	24.05	0.41
WestTribClow	1709	PF 7	70.00	649.10	651.16	650.57	651.25	0.002078	2.42	28.90	24.48	0.39
WestTribClow	1709	PF 8	80.00	649.10	651.29	650.64	651.39	0.001944	2.49	32.19	24.88	0.39
WestTribClow	1709	PF 9	90.00	649.10	651.42	650.70	651.52	0.001841	2.54	35.37	25.26	0.38
WestTribClow	1709	PF 10	100.00	649.10	651.54	650.76	651.65	0.001761	2.60	38.44	25.63	0.37
WestTribClow	1709	PF 11	125.00	649.10	651.82	650.90	651.94	0.001623	2.73	45.72	26.46	0.37
WestTribClow	1709	PF 12	150.00	649.10	652.08	651.03	652.20	0.001534	2.85	52.56	27.19	0.36
WestTribClow	1709	PF 13	175.00	649.10	652.31	651.15	652.45	0.001470	2.97	59.01	27.78	0.36
WestTribClow	1709	PF 14	200.00	649.10	652.53	651.27	652.68	0.001427	3.07	65.13	28.32	0.36
WestTribClow	1709	PF 15	225.00	649.10	652.73	651.36	652.89	0.001395	3.17	70.99	28.84	0.36
WestTribClow	1709	PF 16	250.00	649.10	652.93	651.48	653.09	0.001372	3.26	76.63	29.32	0.36
WestTribClow	1709	PF 17	275.00	649.10	653.11	651.57	653.29	0.001360	3.35	82.07	29.89	0.36
WestTribClow	1709	PF 18	300.00	649.10	653.29	651.67	653.47	0.001353	3.43	87.39	30.51	0.36
WestTribClow	1709	PF 19	325.00	649.10	653.46	651.76	653.65	0.001349	3.51	92.54	31.09	0.36
WestTribClow	1709	PF 20	350.00	649.10	653.61	651.85	653.81	0.001352	3.59	97.44	31.64	0.36
WestTribClow	1709	PF 21	375.00	649.10	653.76	651.94	653.97	0.001354	3.67	102.25	32.17	0.36
WestTribClow	1709	PF 22	400.00	649.10	653.91	652.02	654.13	0.001351	3.73	107.11	32.69	0.36
WestTribClow	1709	PF 23	425.00	649.10	654.06	652.11	654.28	0.001359	3.80	111.87	33.42	0.37
WestTribClow	1709	PF 24	450.00	649.10	654.19	652.20	654.42	0.001381	3.86	116.51	34.44	0.37
WestTribClow	1709	PF 25	475.00	649.10	654.29	652.27	654.54	0.001434	3.96	119.93	35.17	0.38
WestTribClow	1709	PF 26	500.00	649.10	654.38	652.35	654.63	0.001494	4.07	123.00	35.81	0.39
WestTribClow	1709	PF 27	525.00	649.10	654.46	652.42	654.73	0.001549	4.16	126.12	36.45	0.39
WestTribClow	1709	PF 28	550.00	649.10	654.47	652.50	654.76	0.001697	4.36	126.20	36.47	0.41
WestTribClow	1709	PF 29	575.00	649.10	654.54	652.58	654.85	0.001765	4.46	128.78	37.80	0.42
WestTribClow	1709	PF 30	600.00	649.10	654.60	652.63	654.93	0.001832	4.57	131.32	39.25	0.43
WestTribClow	1627	PF 1	10.00	648.90	649.74	649.41	649.77	0.002263	1.50	6.67	12.98	0.37
WestTribClow	1627	PF 2	20.00	648.90	650.05	649.62	650.10	0.002099	1.76	11.35	16.32	0.37
WestTribClow	1627	PF 3	30.00	648.90	650.30	649.78	650.36	0.001857	1.92	15.58	17.81	0.36
WestTribClow	1627	PF 4	40.00	648.90	650.51	649.91	650.58	0.001740	2.06	19.44	19.07	0.36
WestTribClow	1627	PF 5	50.00	648.90	650.70	650.02	650.77	0.001663	2.17	23.07	20.18	0.36
WestTribClow	1627	PF 6	60.00	648.90	650.87	650.11	650.94	0.001604	2.26	26.56	21.19	0.36
WestTribClow	1627	PF 7	70.00	648.90	651.02	650.20	651.10	0.001564	2.34	29.86	22.06	0.36
WestTribClow	1627	PF 8	80.00	648.90	651.16	650.28	651.25	0.001518	2.43	32.97	22.55	0.35
WestTribClow	1627	PF 9	90.00	648.90	651.29	650.36	651.39	0.001483	2.50	35.96	23.01	0.35
WestTribClow	1627	PF 10	100.00	648.90	651.41	650.43	651.52	0.001456	2.57	38.84	23.44	0.35
WestTribClow	1627	PF 11	125.00	648.90	651.70	650.59	651.81	0.001413	2.74	45.66	24.44	0.35
WestTribClow	1627	PF 12	150.00	648.90	651.95	650.75	652.08	0.001387	2.88	52.05	25.34	0.35
WestTribClow	1627	PF 13	175.00	648.90	652.19	650.90	652.33	0.001375	3.01	58.13	26.26	0.36
WestTribClow	1627	PF 14	200.00	648.90	652.41	651.03	652.56	0.001367	3.13	63.98	27.13	0.36
WestTribClow	1627	PF 15	225.00	648.90	652.61	651.16	652.78	0.001360	3.23	69.64	27.96	0.36
WestTribClow	1627	PF 16	250.00	648.90	652.81	651.26	652.98	0.001354	3.33	75.16	28.74	0.36
WestTribClow	1627	PF 17	275.00	648.90	652.99	651.38	653.17	0.001349	3.41	80.53	29.47	0.36
WestTribClow	1627	PF 18	300.00	648.90	653.17	651.48	653.36	0.001348	3.50	85.79	30.26	0.37
WestTribClow	1627	PF 19	325.00	648.90	653.34	651.57	653.54	0.001349	3.57	90.92	31.02	0.37
WestTribClow	1627	PF 20	350.00	648.90	653.49	651.69	653.70	0.001354	3.65	95.81	31.72	0.37
WestTribClow	1627	PF 21	375.00	648.90	653.64	651.79	653.86	0.001358	3.73	100.64	32.40	0.37
WestTribClow	1627	PF 22	400.00	648.90	653.79	651.87	654.02	0.001356	3.79	105.56	33.07	0.37
WestTribClow	1627	PF 23	425.00	648.90	653.94	651.96	654.17	0.001355	3.85	110.39	33.72	0.38
WestTribClow	1627	PF 24	450.00	648.90	654.08	652.05	654.31	0.001339	3.91	115.04	34.54	0.37
WestTribClow	1627	PF 25	475.00	648.90	654.17	652.14	654.42	0.001362	4.02	118.32	35.21	0.38
WestTribClow	1627	PF 26	500.00	648.90	654.25	652.22	654.52	0.001397	4.13	121.20	35.79	0.39

HEC-RAS Plan: MODEXIST River: WestTribClow Reach: WestTribClow (Continued)

Reach	River Sta	Profile	Q Total (cfs)	Min Ch El (ft)	W.S. Elev (ft)	Crit W.S. (ft)	E.G. Elev (ft)	E.G. Slope (ft/ft)	Vel Chnl (ft/s)	Flow Area (sq ft)	Top Width (ft)	Froude # Chl
WestTribClow	1627	PF 27	525.00	648.90	654.35	652.30	654.61	0.001364	4.16	143.44	81.75	0.38
WestTribClow	1627	PF 28	550.00	648.90	654.34	652.39	654.63	0.001515	4.37	142.57	81.72	0.40
WestTribClow	1627	PF 29	575.00	648.90	654.40	652.47	654.71	0.001547	4.47	147.63	81.87	0.41
WestTribClow	1627	PF 30	600.00	648.90	654.47	652.53	654.79	0.001579	4.57	152.56	82.01	0.41
WestTribClow	1500	PF 1	10.00	648.50	649.42	649.14	649.46	0.002626	1.62	6.16	11.89	0.40
WestTribClow	1500	PF 2	20.00	648.50	649.79	649.34	649.85	0.001939	1.81	11.02	14.22	0.36
WestTribClow	1500	PF 3	30.00	648.50	650.07	649.49	650.13	0.001721	1.97	15.20	15.71	0.35
WestTribClow	1500	PF 4	40.00	648.50	650.29	649.63	650.36	0.001622	2.14	18.73	16.35	0.35
WestTribClow	1500	PF 5	50.00	648.50	650.48	649.74	650.56	0.001595	2.29	21.86	16.89	0.35
WestTribClow	1500	PF 6	60.00	648.50	650.65	649.85	650.74	0.001587	2.42	24.75	17.38	0.36
WestTribClow	1500	PF 7	70.00	648.50	650.80	649.94	650.90	0.001602	2.56	27.38	17.82	0.36
WestTribClow	1500	PF 8	80.00	648.50	650.94	650.03	651.05	0.001626	2.68	29.84	18.21	0.37
WestTribClow	1500	PF 9	90.00	648.50	651.06	650.12	651.18	0.001649	2.80	32.19	18.60	0.37
WestTribClow	1500	PF 10	100.00	648.50	651.18	650.19	651.31	0.001673	2.90	34.46	18.98	0.38
WestTribClow	1500	PF 11	125.00	648.50	651.46	650.38	651.61	0.001729	3.14	39.79	19.84	0.39
WestTribClow	1500	PF 12	150.00	648.50	651.71	650.53	651.88	0.001777	3.35	44.79	20.62	0.40
WestTribClow	1500	PF 13	175.00	648.50	651.93	650.69	652.13	0.001818	3.53	49.53	21.33	0.41
WestTribClow	1500	PF 14	200.00	648.50	652.14	650.84	652.35	0.001854	3.70	54.07	21.99	0.42
WestTribClow	1500	PF 15	225.00	648.50	652.34	650.97	652.57	0.001885	3.85	58.45	22.61	0.42
WestTribClow	1500	PF 16	250.00	648.50	652.52	651.12	652.77	0.001910	3.99	62.72	23.20	0.43
WestTribClow	1500	PF 17	275.00	648.50	652.70	651.25	652.96	0.001933	4.11	66.87	23.76	0.43
WestTribClow	1500	PF 18	300.00	648.50	652.87	651.35	653.15	0.001954	4.23	70.90	24.28	0.44
WestTribClow	1500	PF 19	325.00	648.50	653.03	651.47	653.32	0.001965	4.34	74.81	24.98	0.44
WestTribClow	1500	PF 20	350.00	648.50	653.18	651.60	653.49	0.001941	4.46	78.66	25.49	0.44
WestTribClow	1500	PF 21	375.00	648.50	653.32	651.71	653.64	0.001922	4.57	82.56	25.94	0.44
WestTribClow	1500	PF 22	400.00	648.50	653.47	651.82	653.80	0.001896	4.67	86.70	26.40	0.44
WestTribClow	1500	PF 23	425.00	648.50	653.60	651.92	653.96	0.001877	4.77	90.85	26.87	0.44
WestTribClow	1500	PF 24	450.00	648.50	653.73	652.02	654.10	0.001865	4.87	94.96	27.34	0.44
WestTribClow	1500	PF 25	475.00	648.50	653.81	652.12	654.20	0.001943	5.03	97.40	27.81	0.45
WestTribClow	1500	PF 26	500.00	648.50	653.87	652.21	654.29	0.002047	5.22	99.28	28.28	0.47
WestTribClow	1500	PF 27	525.00	648.50	653.93	652.31	654.38	0.002125	5.38	101.60	28.75	0.48
WestTribClow	1500	PF 28	550.00	648.50	654.05	652.40	654.41	0.001805	5.05	158.04	380.36	0.44
WestTribClow	1500	PF 29	575.00	648.50	654.11	652.49	654.49	0.001858	5.17	163.11	380.82	0.45
WestTribClow	1500	PF 30	600.00	648.50	654.16	652.58	654.56	0.001910	5.30	168.06	381.26	0.46
WestTribClow	1350	PF 1	10.00	648.10	649.22	648.65	649.24	0.000883	1.17	8.54	11.62	0.24
WestTribClow	1350	PF 2	20.00	648.10	649.60	648.88	649.64	0.000999	1.50	13.31	13.51	0.27
WestTribClow	1350	PF 3	30.00	648.10	649.88	649.06	649.93	0.001091	1.74	17.22	14.89	0.29
WestTribClow	1350	PF 4	40.00	648.10	650.10	649.20	650.15	0.001171	1.94	20.57	15.83	0.30
WestTribClow	1350	PF 5	50.00	648.10	650.28	649.33	650.35	0.001240	2.13	23.52	16.47	0.31
WestTribClow	1350	PF 6	60.00	648.10	650.44	649.44	650.52	0.001299	2.29	26.26	17.04	0.32
WestTribClow	1350	PF 7	70.00	648.10	650.58	649.55	650.68	0.001368	2.44	28.72	17.54	0.34
WestTribClow	1350	PF 8	80.00	648.10	650.71	649.65	650.82	0.001437	2.58	30.99	17.99	0.35
WestTribClow	1350	PF 9	90.00	648.10	650.83	649.75	650.95	0.001497	2.71	33.19	18.41	0.36
WestTribClow	1350	PF 10	100.00	648.10	650.95	649.84	651.07	0.001550	2.83	35.31	18.81	0.36
WestTribClow	1350	PF 11	125.00	648.10	651.21	650.04	651.36	0.001656	3.10	40.33	19.62	0.38
WestTribClow	1350	PF 12	150.00	648.10	651.44	650.21	651.62	0.001741	3.33	45.03	20.33	0.39
WestTribClow	1350	PF 13	175.00	648.10	651.66	650.38	651.85	0.001813	3.54	49.49	20.98	0.41
WestTribClow	1350	PF 14	200.00	648.10	651.86	650.53	652.07	0.001877	3.72	53.73	21.57	0.42
WestTribClow	1350	PF 15	225.00	648.10	652.05	650.68	652.28	0.001933	3.89	57.84	22.16	0.42
WestTribClow	1350	PF 16	250.00	648.10	652.22	650.82	652.48	0.001985	4.04	61.84	22.78	0.43
WestTribClow	1350	PF 17	275.00	648.10	652.39	650.94	652.67	0.002030	4.18	65.75	23.38	0.44
WestTribClow	1350	PF 18	300.00	648.10	652.55	651.08	652.84	0.002070	4.31	69.57	23.94	0.45
WestTribClow	1350	PF 19	325.00	648.10	652.71	651.20	653.01	0.002105	4.43	73.31	24.48	0.45
WestTribClow	1350	PF 20	350.00	648.10	652.86	651.31	653.18	0.002135	4.55	77.00	25.00	0.46
WestTribClow	1350	PF 21	375.00	648.10	653.00	651.43	653.34	0.002162	4.65	80.63	25.51	0.46
WestTribClow	1350	PF 22	400.00	648.10	653.15	651.53	653.50	0.002212	4.74	84.37	26.41	0.47
WestTribClow	1350	PF 23	425.00	648.10	653.28	651.62	653.65	0.002255	4.82	88.09	27.28	0.47
WestTribClow	1350	PF 24	450.00	648.10	653.42	651.73	653.79	0.002282	4.90	92.40	28.15	0.48
WestTribClow	1350	PF 25	475.00	648.10	653.48	651.84	653.88	0.002404	5.08	94.35	28.40	0.49
WestTribClow	1350	PF 26	500.00	648.10	653.60	651.94	653.95	0.002139	4.91	144.04	244.68	0.47
WestTribClow	1350	PF 27	525.00	648.10	653.67	652.03	654.04	0.002164	5.01	153.41	256.44	0.47
WestTribClow	1350	PF 28	550.00	648.10	653.73	652.13	654.11	0.002200	5.11	162.23	267.98	0.47
WestTribClow	1350	PF 29	575.00	648.10	653.78	652.22	654.18	0.002272	5.24	169.15	277.34	0.48
WestTribClow	1350	PF 30	600.00	648.10	653.84	652.31	654.24	0.002314	5.34	177.17	287.93	0.49
WestTribClow	1200	PF 1	10.00	648.00	648.86	648.66	648.96	0.006235	2.55	3.92	7.14	0.61
WestTribClow	1200	PF 2	20.00	648.00	649.17	648.94	649.32	0.006681	3.09	6.48	9.37	0.65
WestTribClow	1200	PF 3	30.00	648.00	649.41	649.16	649.58	0.006669	3.37	8.90	11.24	0.67
WestTribClow	1200	PF 4	40.00	648.00	649.59	649.34	649.79	0.006639	3.59	11.13	12.73	0.68
WestTribClow	1200	PF 5	50.00	648.00	649.75	649.48	649.97	0.006559	3.77	13.27	14.01	0.68
WestTribClow	1200	PF 6	60.00	648.00	649.90	649.60	650.13	0.006414	3.90	15.38	15.17	0.68
WestTribClow	1200	PF 7	70.00	648.00	650.03	649.71	650.28	0.006206	4.01	17.46	16.10	0.68
WestTribClow	1200	PF 8	80.00	648.00	650.14	649.81	650.41	0.005971	4.13	19.35	16.51	0.67
WestTribClow	1200	PF 9	90.00	648.00	650.26	649.92	650.54	0.005775	4.25	21.20	16.89	0.67

HEC-RAS Plan: MODEXIST River: WestTribClow Reach: WestTribClow (Continued)

Reach	River Sta	Profile	Q Total (cfs)	Min Ch El (ft)	W.S. Elev (ft)	Crit W.S. (ft)	E.G. Elev (ft)	E.G. Slope (ft/ft)	Vel Chnl (ft/s)	Flow Area (sq ft)	Top Width (ft)	Froude # Chl
WestTribClow	1200	PF 10	100.00	648.00	650.36	650.01	650.65	0.005619	4.35	22.99	17.26	0.66
WestTribClow	1200	PF 11	125.00	648.00	650.60	650.19	650.93	0.005312	4.58	27.31	18.12	0.66
WestTribClow	1200	PF 12	150.00	648.00	650.83	650.36	651.18	0.005093	4.77	31.43	18.90	0.65
WestTribClow	1200	PF 13	175.00	648.00	651.03	650.51	651.41	0.004926	4.94	35.40	19.60	0.65
WestTribClow	1200	PF 14	200.00	648.00	651.22	650.64	651.63	0.004783	5.10	39.20	20.17	0.64
WestTribClow	1200	PF 15	225.00	648.00	651.40	650.79	651.83	0.004670	5.25	42.89	20.71	0.64
WestTribClow	1200	PF 16	250.00	648.00	651.58	650.93	652.03	0.004577	5.38	46.48	21.23	0.64
WestTribClow	1200	PF 17	275.00	648.00	651.74	651.06	652.21	0.004496	5.50	49.99	21.72	0.64
WestTribClow	1200	PF 18	300.00	648.00	651.90	651.18	652.39	0.004430	5.62	53.41	22.19	0.64
WestTribClow	1200	PF 19	325.00	648.00	652.05	651.29	652.55	0.004373	5.72	56.77	22.64	0.64
WestTribClow	1200	PF 20	350.00	648.00	652.19	651.41	652.72	0.004320	5.83	60.07	23.07	0.64
WestTribClow	1200	PF 21	375.00	648.00	652.33	651.52	652.87	0.004271	5.92	63.34	23.49	0.64
WestTribClow	1200	PF 22	400.00	648.00	652.47	651.62	653.03	0.004224	6.01	66.57	23.90	0.63
WestTribClow	1200	PF 23	425.00	648.00	652.60	651.72	653.17	0.004186	6.10	69.73	24.29	0.63
WestTribClow	1200	PF 24	450.00	648.00	652.73	651.81	653.32	0.004147	6.18	72.87	24.68	0.63
WestTribClow	1200	PF 25	475.00	648.00	652.92	651.92	653.43	0.003539	5.86	108.17	156.57	0.59
WestTribClow	1200	PF 26	500.00	648.00	653.08	652.01	653.56	0.003206	5.72	130.72	208.51	0.56
WestTribClow	1200	PF 27	525.00	648.00	653.18	652.10	653.65	0.003066	5.71	148.08	236.87	0.55
WestTribClow	1200	PF 28	550.00	648.00	653.29	652.19	653.73	0.002872	5.65	168.14	257.27	0.54
WestTribClow	1200	PF 29	575.00	648.00	653.20	652.27	653.75	0.003554	6.18	152.42	242.78	0.60
WestTribClow	1200	PF 30	600.00	648.00	653.29	652.37	653.82	0.003417	6.16	168.20	257.32	0.59
WestTribClow	1100	PF 1	10.00	647.40	648.29	648.11	648.37	0.005375	2.29	4.36	8.46	0.56
WestTribClow	1100	PF 2	20.00	647.40	648.58	648.34	648.71	0.005509	2.85	7.02	9.91	0.60
WestTribClow	1100	PF 3	30.00	647.40	648.80	648.52	648.96	0.005584	3.22	9.31	11.01	0.62
WestTribClow	1100	PF 4	40.00	647.40	648.98	648.68	649.17	0.005768	3.53	11.32	11.88	0.64
WestTribClow	1100	PF 5	50.00	647.40	649.12	648.81	649.35	0.005926	3.82	13.09	12.43	0.66
WestTribClow	1100	PF 6	60.00	647.40	649.26	648.94	649.51	0.005958	4.05	14.82	12.90	0.67
WestTribClow	1100	PF 7	70.00	647.40	649.38	649.06	649.66	0.006029	4.26	16.43	13.33	0.68
WestTribClow	1100	PF 8	80.00	647.40	649.50	649.16	649.80	0.006060	4.44	18.01	13.74	0.68
WestTribClow	1100	PF 9	90.00	647.40	649.60	649.26	649.94	0.006122	4.62	19.50	14.12	0.69
WestTribClow	1100	PF 10	100.00	647.40	649.71	649.35	650.06	0.006095	4.75	21.03	14.49	0.70
WestTribClow	1100	PF 11	125.00	647.40	649.95	649.57	650.35	0.006173	5.09	24.53	15.31	0.71
WestTribClow	1100	PF 12	150.00	647.40	650.18	649.75	650.62	0.006050	5.33	28.15	16.12	0.71
WestTribClow	1100	PF 13	175.00	647.40	650.37	649.94	650.86	0.006081	5.58	31.39	16.81	0.72
WestTribClow	1100	PF 14	200.00	647.40	650.57	650.10	651.08	0.006022	5.77	34.69	17.48	0.72
WestTribClow	1100	PF 15	225.00	647.40	650.75	650.26	651.29	0.005959	5.93	37.92	18.12	0.72
WestTribClow	1100	PF 16	250.00	647.40	650.92	650.41	651.50	0.005870	6.07	41.16	18.73	0.72
WestTribClow	1100	PF 17	275.00	647.40	651.09	650.56	651.69	0.005774	6.20	44.38	19.32	0.72
WestTribClow	1100	PF 18	300.00	647.40	651.25	650.69	651.87	0.005703	6.32	47.50	19.88	0.72
WestTribClow	1100	PF 19	325.00	647.40	651.41	650.81	652.05	0.005625	6.42	50.62	20.42	0.72
WestTribClow	1100	PF 20	350.00	647.40	651.56	650.93	652.22	0.005540	6.51	53.73	20.95	0.72
WestTribClow	1100	PF 21	375.00	647.40	651.71	651.06	652.38	0.005450	6.59	56.86	21.47	0.71
WestTribClow	1100	PF 22	400.00	647.40	651.85	651.18	652.54	0.005348	6.66	60.04	21.98	0.71
WestTribClow	1100	PF 23	425.00	647.40	651.99	651.29	652.69	0.005279	6.74	63.07	22.46	0.71
WestTribClow	1100	PF 24	450.00	647.40	652.12	651.40	652.84	0.005202	6.80	66.17	22.95	0.71
WestTribClow	1100	PF 25	475.00	647.40	652.26	651.50	652.99	0.005121	6.86	69.28	23.45	0.70
WestTribClow	1100	PF 26	500.00	647.40	652.39	651.59	653.13	0.005035	6.90	72.42	23.93	0.70
WestTribClow	1100	PF 27	525.00	647.40	652.56	651.70	653.25	0.004631	6.75	94.56	192.36	0.67
WestTribClow	1100	PF 28	550.00	647.40	652.68	651.81	653.36	0.004417	6.70	106.81	234.62	0.66
WestTribClow	1100	PF 29	575.00	647.40	652.89	651.89	653.39	0.003355	6.03	179.06	382.33	0.58
WestTribClow	1100	PF 30	600.00	647.40	653.02	651.99	653.47	0.003021	5.83	208.13	408.77	0.55
WestTribClow	1000	PF 1	10.00	646.20	647.20	647.20	647.44	0.019417	3.95	2.53	5.48	1.02
WestTribClow	1000	PF 2	20.00	646.20	647.51	647.51	647.80	0.016950	4.35	4.60	7.81	1.00
WestTribClow	1000	PF 3	30.00	646.20	647.72	647.72	648.06	0.016182	4.69	6.40	9.38	1.00
WestTribClow	1000	PF 4	40.00	646.20	647.88	647.88	648.27	0.015737	4.97	8.05	10.62	1.01
WestTribClow	1000	PF 5	50.00	646.20	648.03	648.03	648.44	0.014980	5.17	9.67	11.56	1.00
WestTribClow	1000	PF 6	60.00	646.20	648.14	648.14	648.60	0.014846	5.49	10.93	11.81	1.00
WestTribClow	1000	PF 7	70.00	646.20	648.24	648.24	648.75	0.014383	5.72	12.23	12.05	1.00
WestTribClow	1000	PF 8	80.00	646.20	648.34	648.34	648.89	0.014163	5.95	13.44	12.27	1.00
WestTribClow	1000	PF 9	90.00	646.20	648.45	648.45	649.03	0.013699	6.12	14.70	12.50	0.99
WestTribClow	1000	PF 10	100.00	646.20	648.53	648.53	649.16	0.013802	6.35	15.75	12.69	1.00
WestTribClow	1000	PF 11	125.00	646.20	648.75	648.75	649.45	0.013183	6.72	18.60	13.19	1.00
WestTribClow	1000	PF 12	150.00	646.20	648.93	648.93	649.72	0.013214	7.12	21.05	13.60	1.01
WestTribClow	1000	PF 13	175.00	646.20	649.13	649.13	649.97	0.012645	7.36	23.77	14.04	1.00
WestTribClow	1000	PF 14	200.00	646.20	649.30	649.30	650.20	0.012479	7.63	26.20	14.42	1.00
WestTribClow	1000	PF 15	225.00	646.20	649.46	649.46	650.43	0.012273	7.87	28.60	14.79	1.00
WestTribClow	1000	PF 16	250.00	646.20	649.62	649.62	650.63	0.012168	8.09	30.89	15.14	1.00
WestTribClow	1000	PF 17	275.00	646.20	649.76	649.76	650.83	0.012104	8.31	33.09	15.46	1.00
WestTribClow	1000	PF 18	300.00	646.20	649.91	649.91	651.02	0.011936	8.48	35.36	15.79	1.00
WestTribClow	1000	PF 19	325.00	646.20	650.04	650.04	651.21	0.011812	8.65	37.56	16.09	1.00
WestTribClow	1000	PF 20	350.00	646.20	650.18	650.18	651.38	0.011718	8.82	39.69	16.35	1.00
WestTribClow	1000	PF 21	375.00	646.20	650.30	650.30	651.55	0.011656	8.98	41.75	16.60	1.00
WestTribClow	1000	PF 22	400.00	646.20	650.42	650.42	651.72	0.011666	9.16	43.69	16.83	1.00
WestTribClow	1000	PF 23	425.00	646.20	650.54	650.54	651.88	0.011523	9.28	45.82	17.08	1.00

HEC-RAS Plan: MODEXIST River: WestTribClow Reach: WestTribClow (Continued)

Reach	River Sta	Profile	Q Total (cfs)	Min Ch El (ft)	W.S. Elev (ft)	Crit W.S. (ft)	E.G. Elev (ft)	E.G. Slope (ft/ft)	Vel Chnl (ft/s)	Flow Area (sq ft)	Top Width (ft)	Froude # Chl
WestTribClow	1000	PF 24	450.00	646.20	650.66	650.66	652.03	0.011446	9.41	47.84	17.32	1.00
WestTribClow	1000	PF 25	475.00	646.20	650.77	650.77	652.18	0.011395	9.54	49.80	17.54	1.00
WestTribClow	1000	PF 26	500.00	646.20	650.88	650.88	652.33	0.011385	9.67	51.68	17.76	1.00
WestTribClow	1000	PF 27	525.00	646.20	650.98	650.98	652.48	0.011393	9.81	53.51	17.96	1.00
WestTribClow	1000	PF 28	550.00	646.20	651.19	651.19	652.61	0.011258	9.57	57.50	20.11	1.00
WestTribClow	1000	PF 29	575.00	646.20	651.36	651.36	652.74	0.011228	9.43	60.96	21.92	1.00
WestTribClow	1000	PF 30	600.00	646.20	651.48	651.48	652.86	0.011316	9.41	63.78	23.29	1.00

WestTribClow Plan: Plan 02 3/29/2022
Sta 10+00

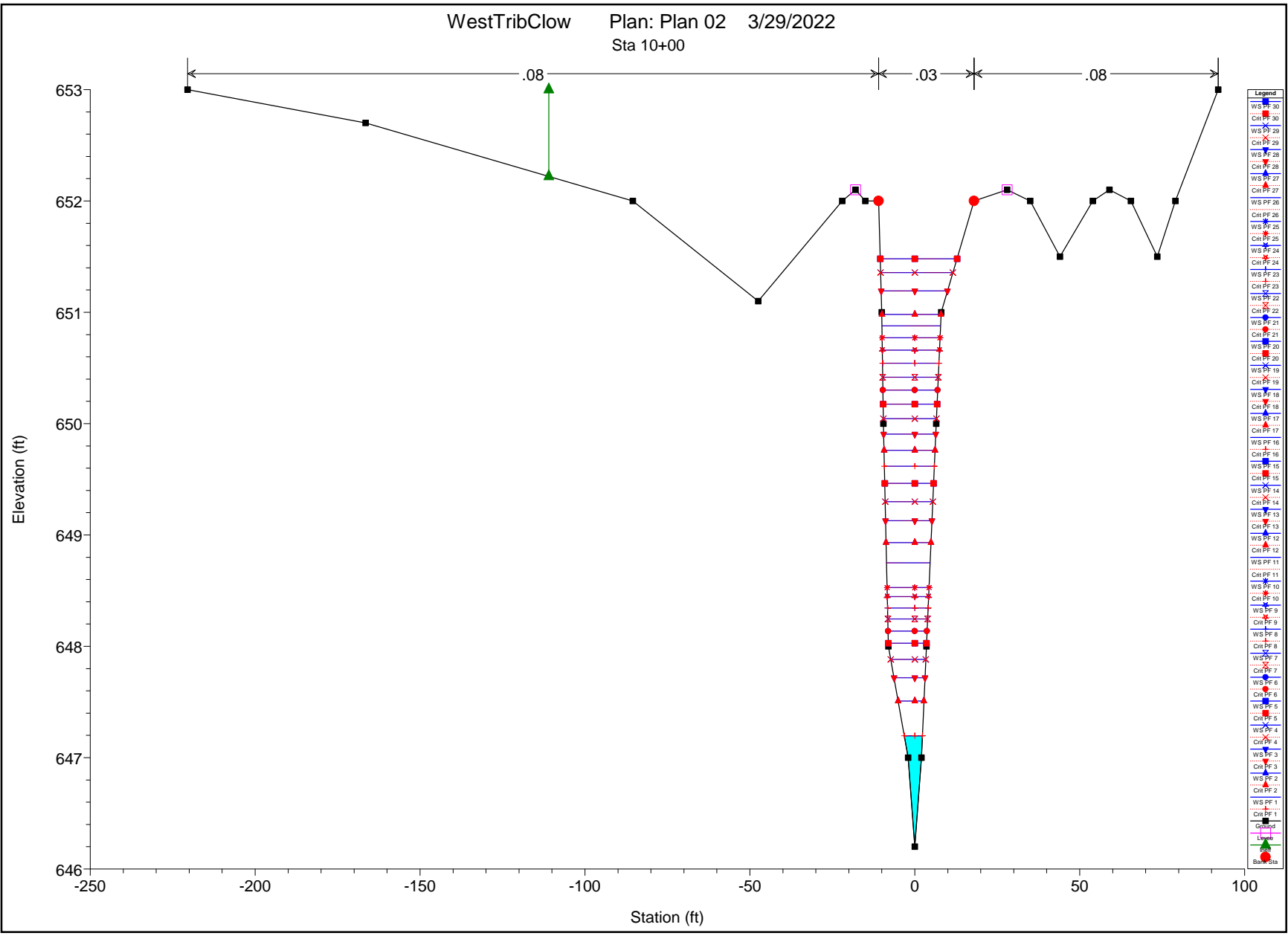

WestTribClow Plan: Plan 02 3/29/2022
Sta: 18+11

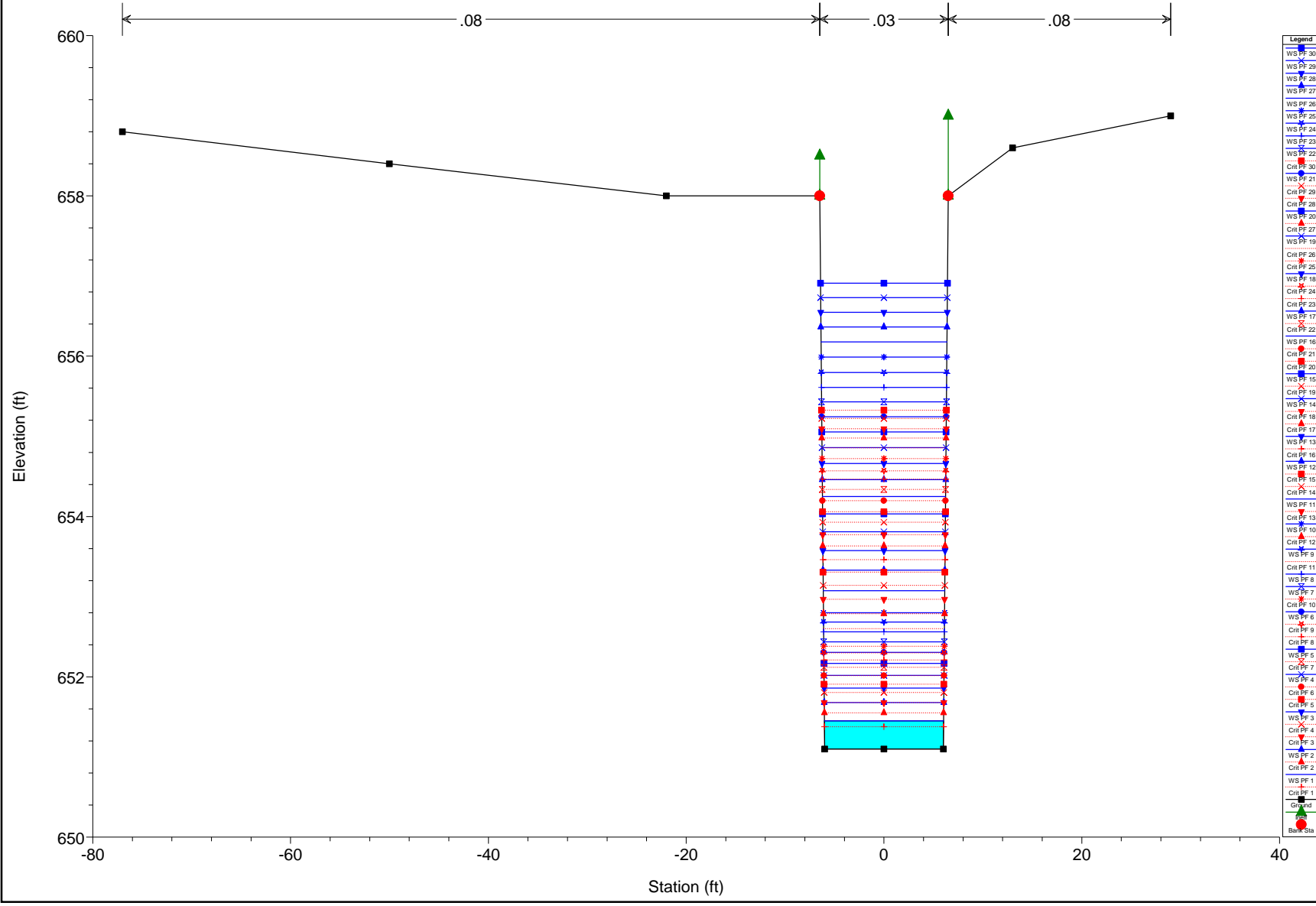

WestTribClow Plan: Plan 02 3/29/2022
 Box Culvert at Golf Cart Crossing (18+00)

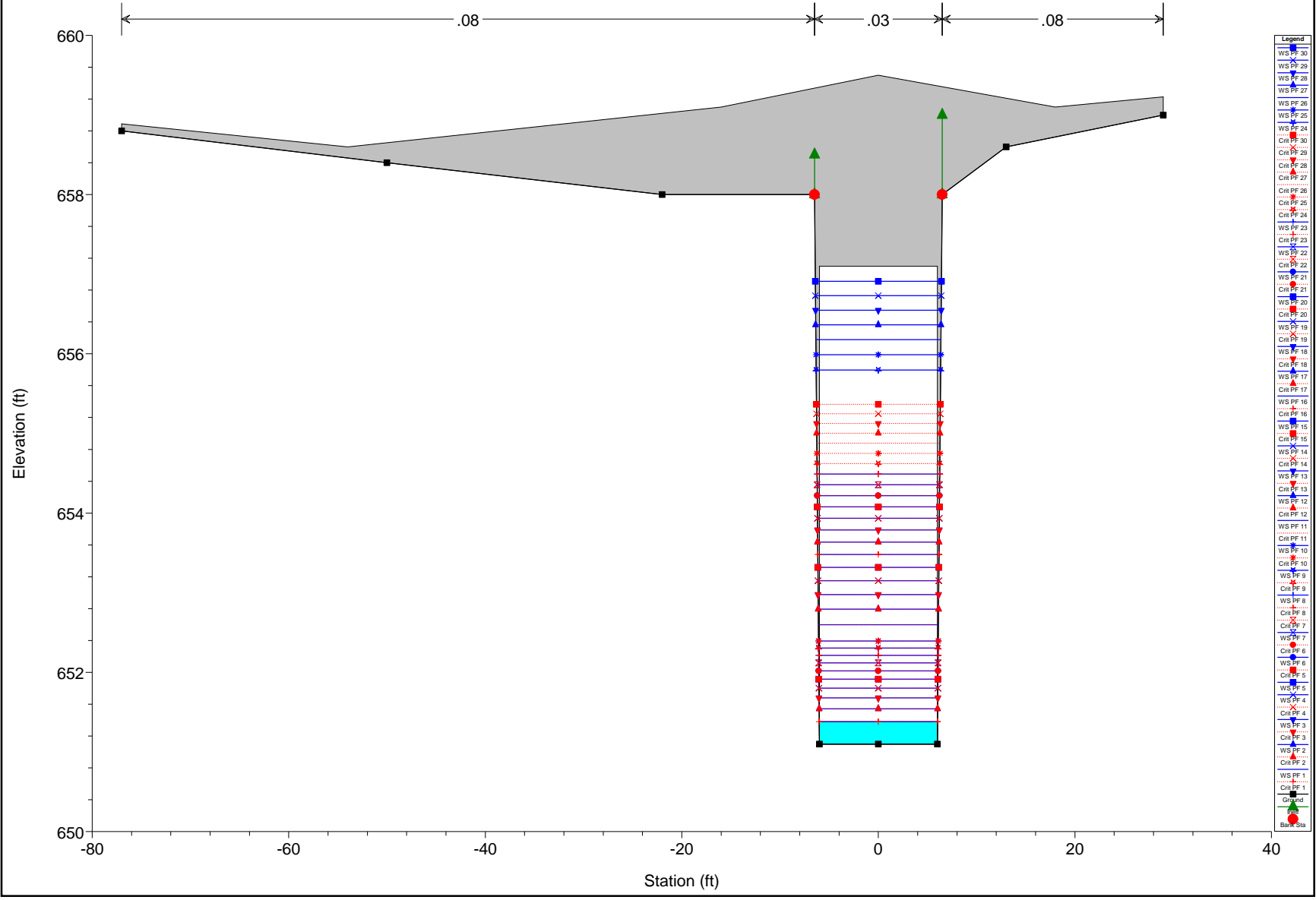

WestTribClow Plan: Plan 02 3/29/2022
 Box Culvert at Golf Cart Crossing (18+00)

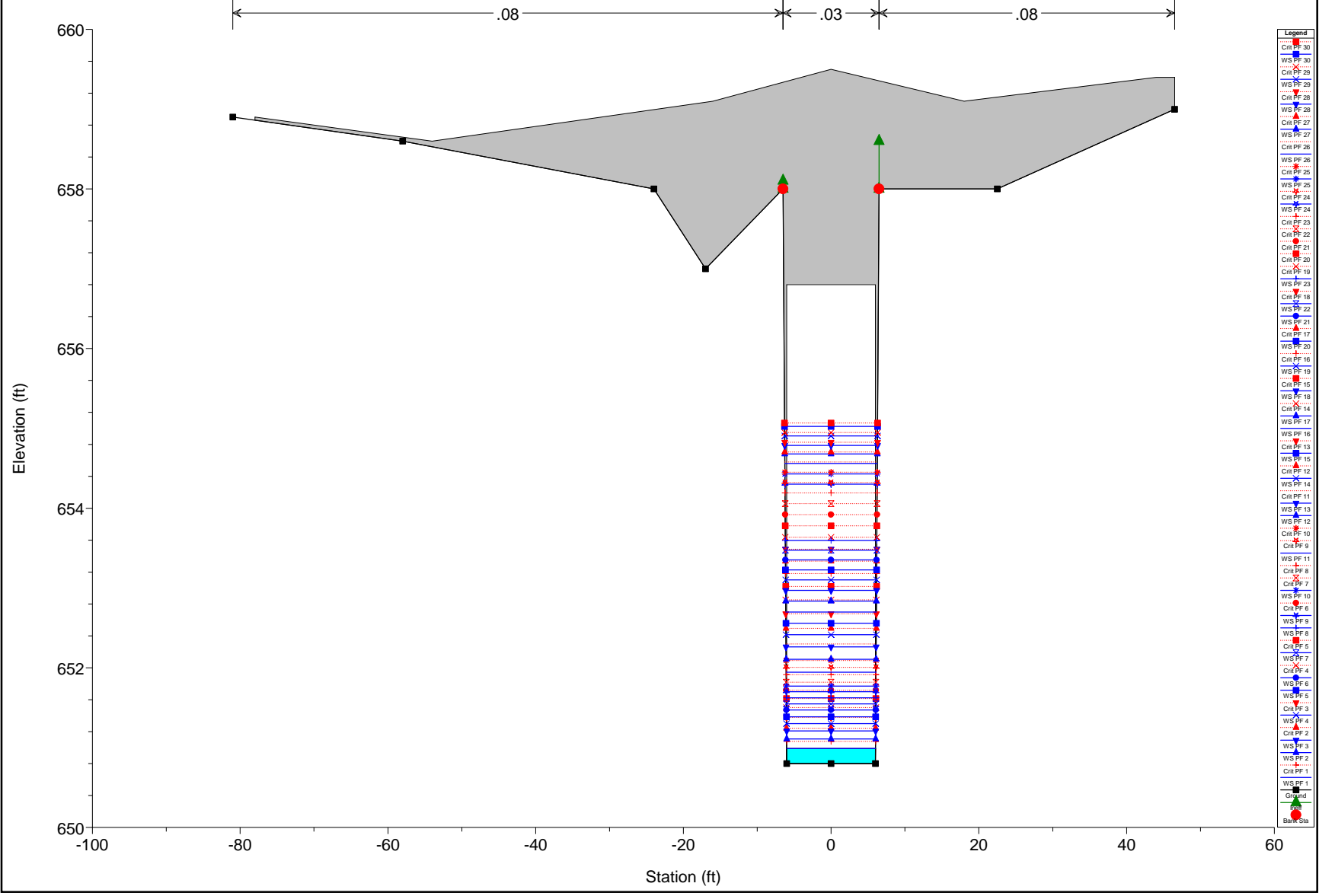

WestTribClow Plan: Plan 02 3/29/2022
Sta: 17+87

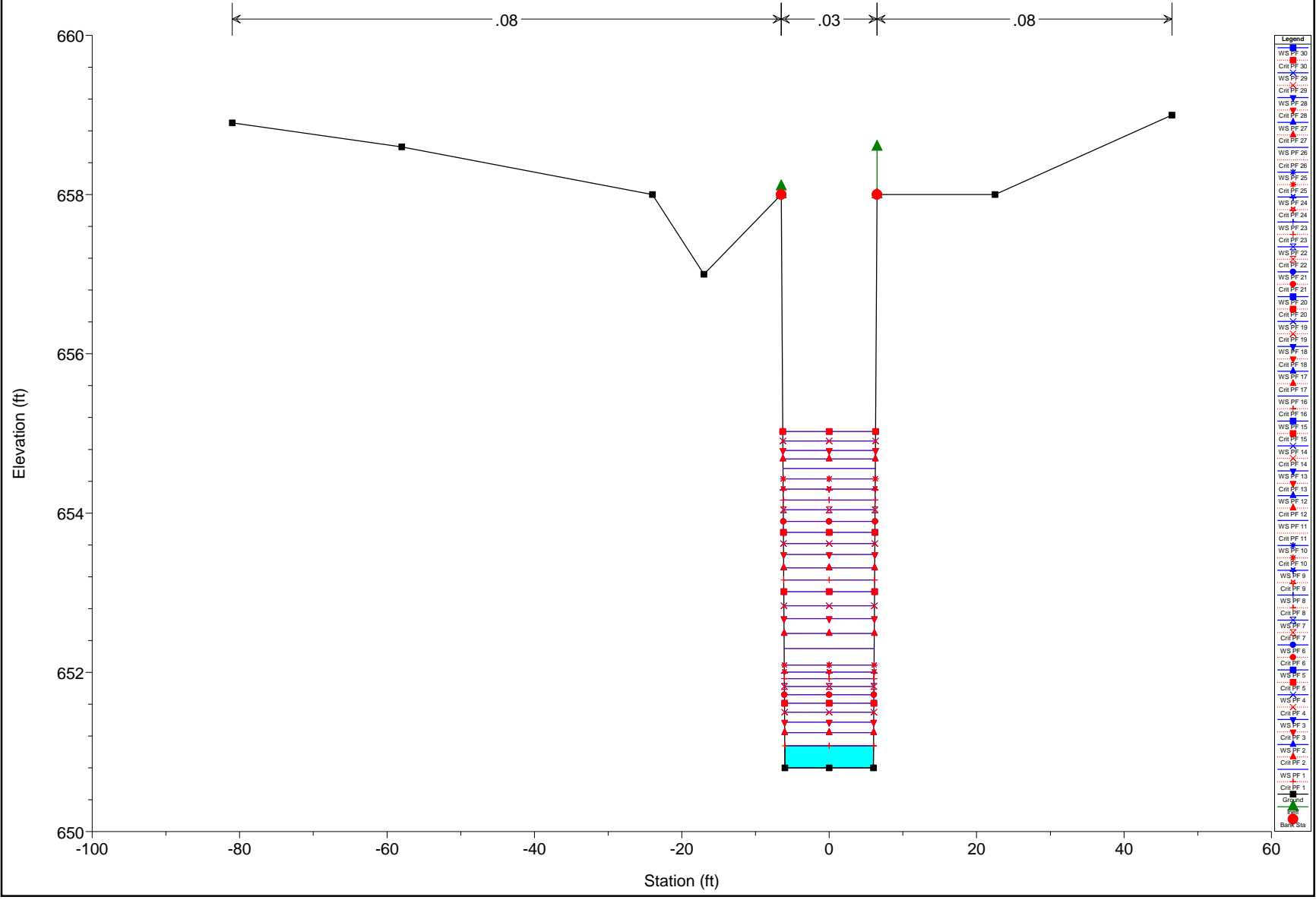

WestTribClow Plan: Plan 02 3/29/2022
17+77

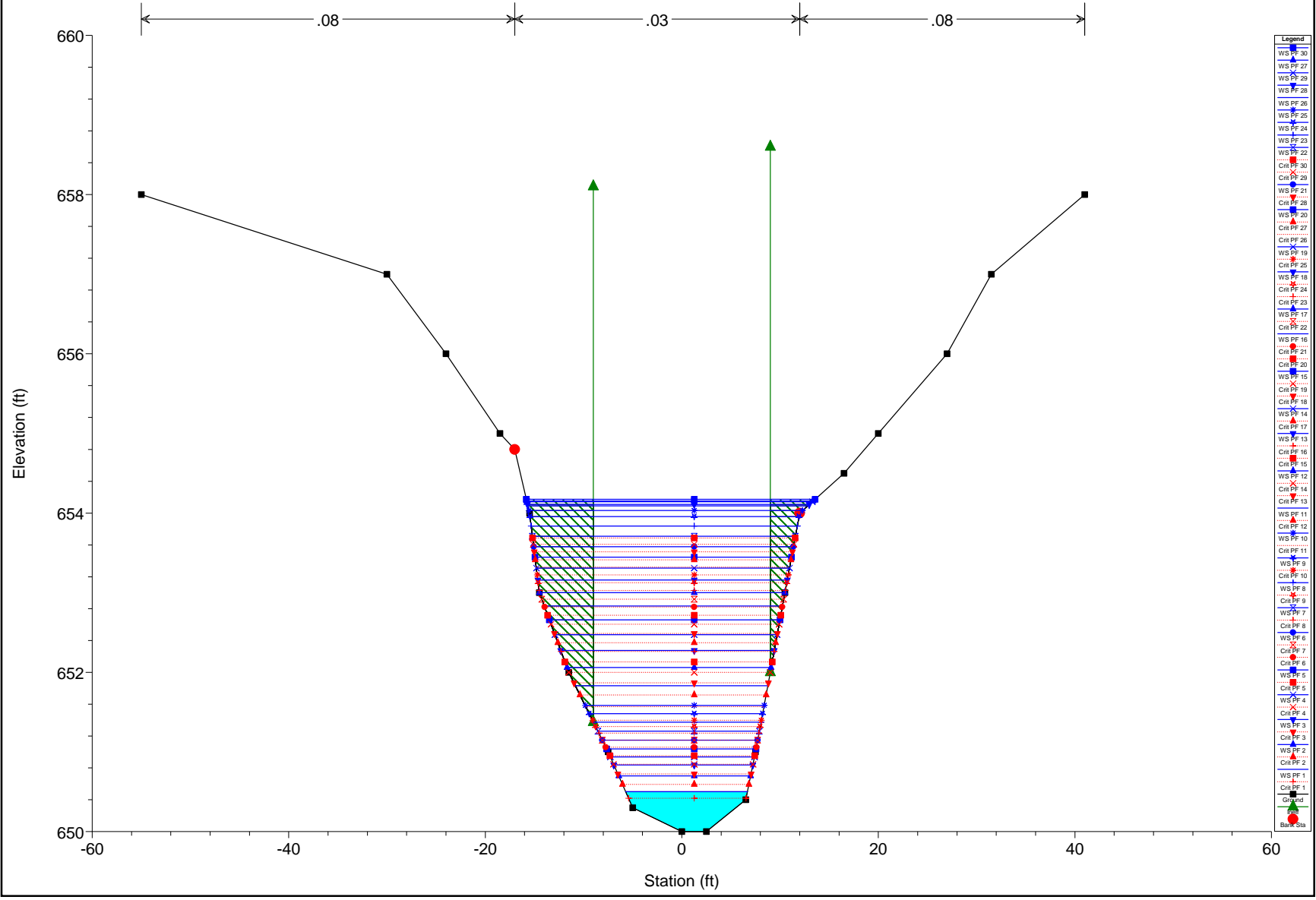

WestTribClow Plan: Plan 02 3/29/2022
Sta 17+09

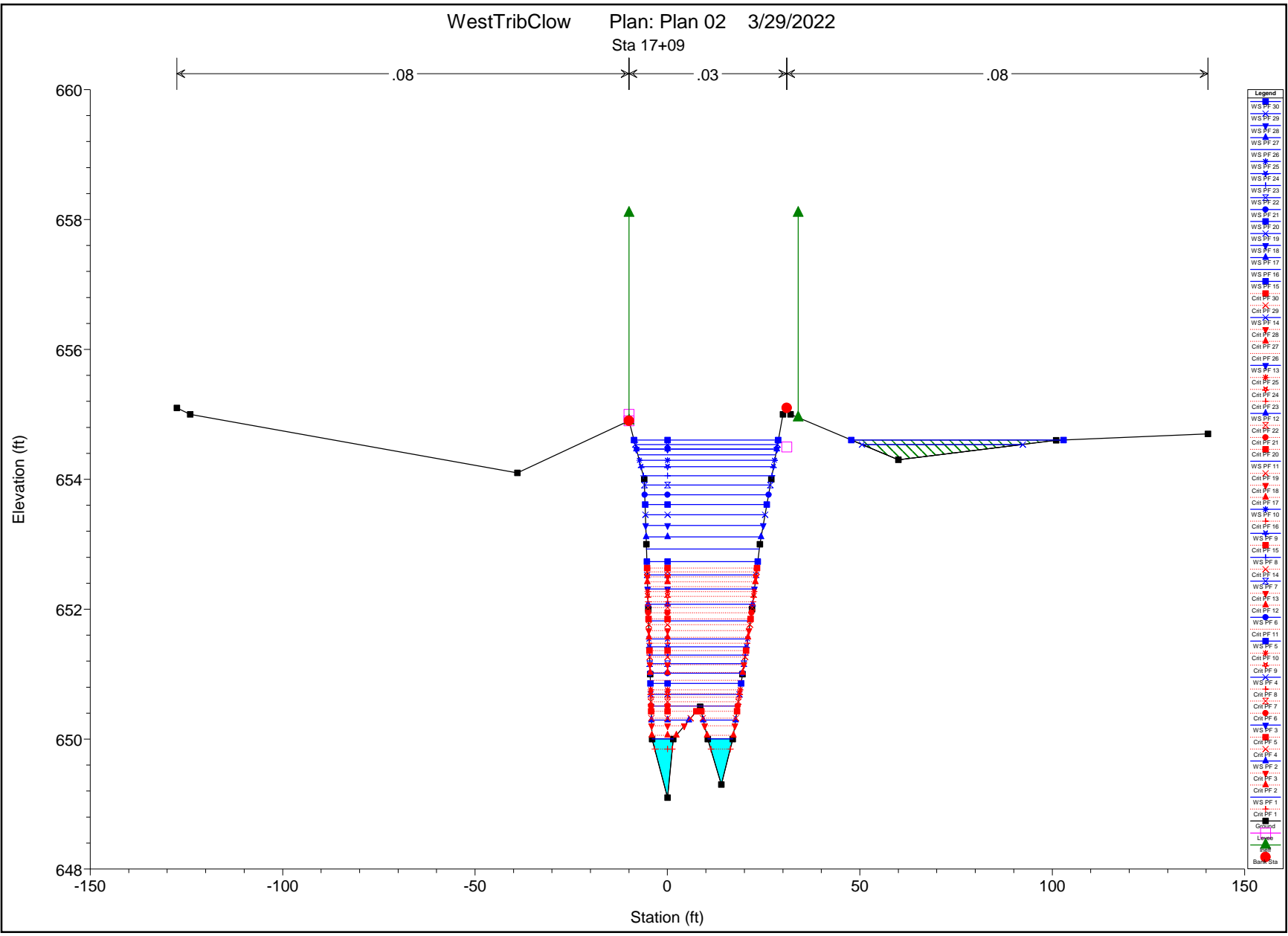

WestTribClow Plan: Plan 02 3/29/2022
Sta 16+27

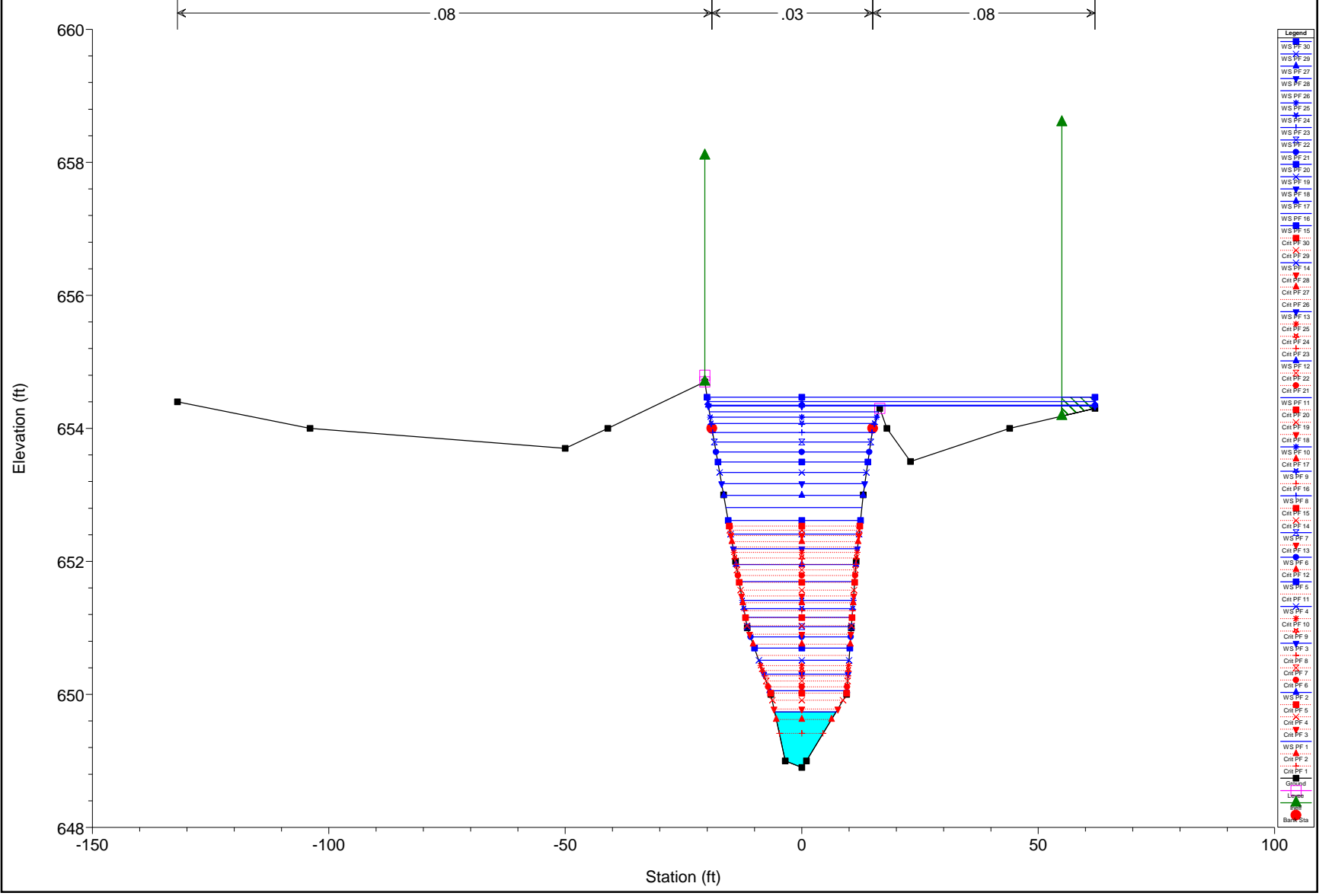

WestTribClow Plan: Plan 02 3/29/2022
Sta: 15+00

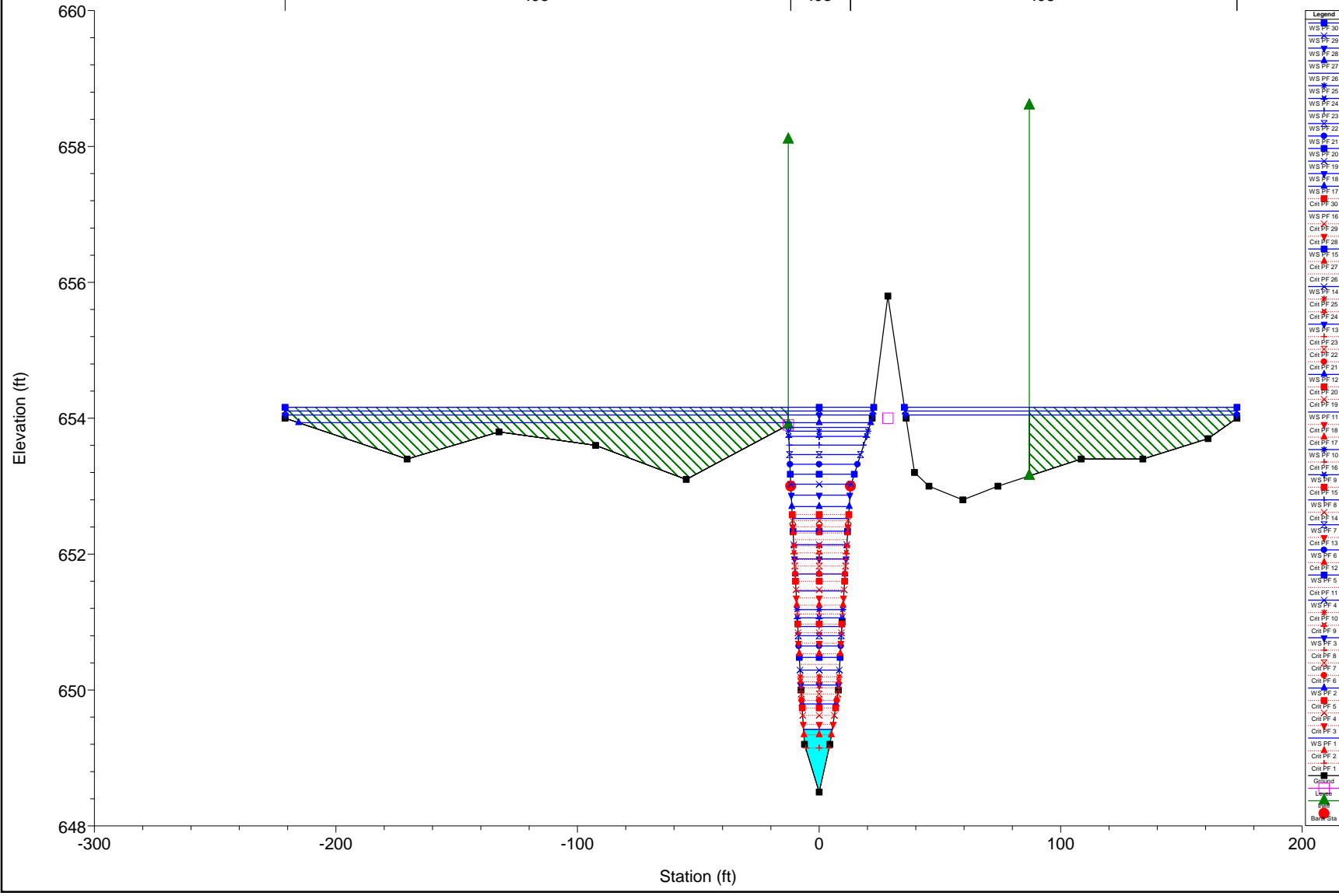

- Legend
- WS PF 30
- WS PF 29
- WS PF 28
- WS PF 27
- WS PF 26
- WS PF 25
- WS PF 24
- WS PF 23
- WS PF 22
- WS PF 21
- WS PF 20
- WS PF 19
- WS PF 18
- WS PF 17
- Crt PF 30
- WS PF 16
- Crt PF 29
- Crt PF 28
- WS PF 15
- Crt PF 27
- Crt PF 26
- WS PF 14
- Crt PF 25
- Crt PF 24
- WS PF 13
- Crt PF 23
- Crt PF 22
- Crt PF 21
- WS PF 12
- Crt PF 20
- Crt PF 19
- WS PF 11
- Crt PF 18
- Crt PF 17
- Crt PF 16
- WS PF 10
- Crt PF 15
- WS PF 9
- Crt PF 14
- WS PF 8
- Crt PF 13
- WS PF 7
- Crt PF 12
- WS PF 6
- Crt PF 11
- WS PF 5
- Crt PF 10
- Crt PF 9
- WS PF 4
- Crt PF 8
- Crt PF 7
- Crt PF 6
- WS PF 3
- Crt PF 5
- Crt PF 4
- Crt PF 3
- WS PF 2
- Crt PF 2
- Crt PF 1
- Ground
- Lvl
- Base

WestTribClow Plan: Plan 02 3/29/2022
Sta 13+50

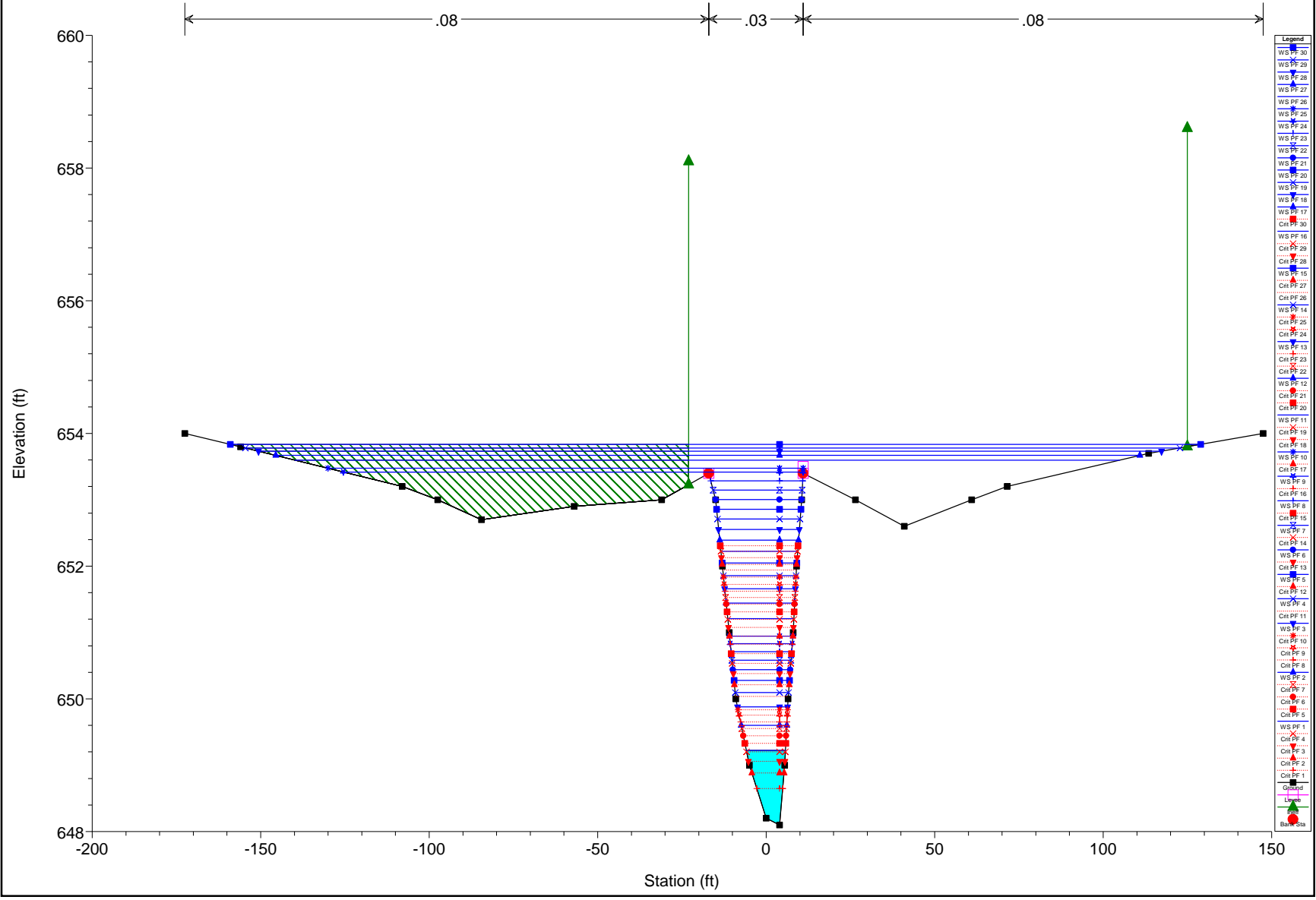

WestTribClow Plan: Plan 02 3/29/2022
Sta 12+00

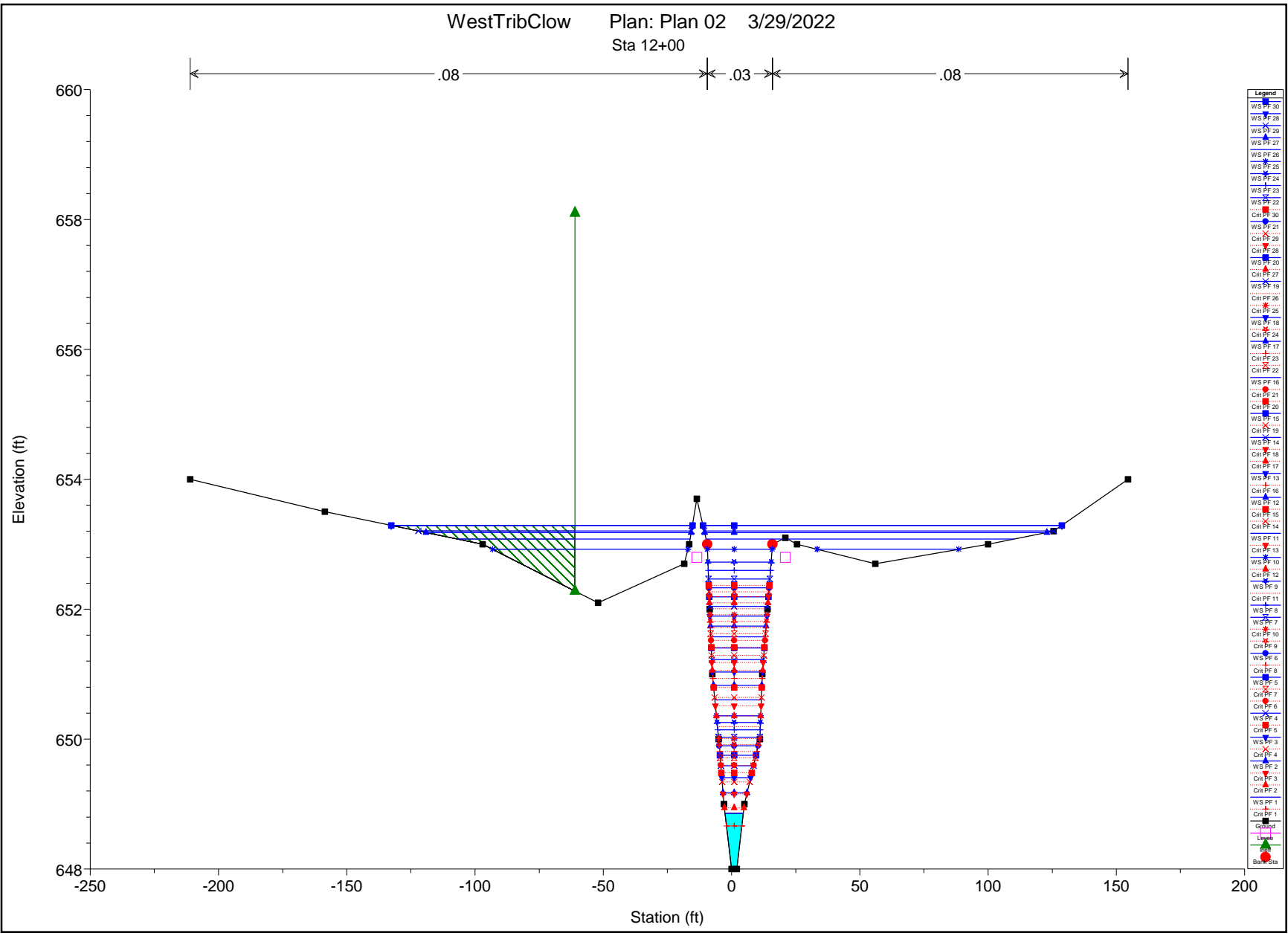

- Legend
- WS PF 30
- WS PF 28
- WS PF 26
- WS PF 27
- WS PF 26
- WS PF 25
- WS PF 24
- WS PF 23
- WS PF 22
- Crt PF 30
- WS PF 21
- Crt PF 29
- Crt PF 28
- WS PF 20
- Crt PF 27
- WS PF 19
- Crt PF 26
- Crt PF 25
- WS PF 18
- Crt PF 24
- WS PF 17
- Crt PF 23
- Crt PF 22
- WS PF 16
- Crt PF 21
- Crt PF 20
- WS PF 15
- Crt PF 19
- WS PF 14
- Crt PF 18
- Crt PF 17
- WS PF 13
- Crt PF 16
- WS PF 12
- Crt PF 15
- Crt PF 14
- WS PF 11
- Crt PF 13
- WS PF 10
- Crt PF 12
- WS PF 9
- Crt PF 11
- WS PF 8
- WS PF 7
- WS PF 6
- Crt PF 10
- Crt PF 9
- WS PF 5
- Crt PF 8
- WS PF 4
- Crt PF 7
- WS PF 3
- Crt PF 6
- WS PF 2
- Crt PF 5
- Crt PF 4
- WS PF 1
- Crt PF 3
- Crt PF 2
- WS PF 1
- Crt PF 1
- Ground
- Bank Sta

WestTribClow Plan: Plan 02 3/29/2022
Sta 11+00

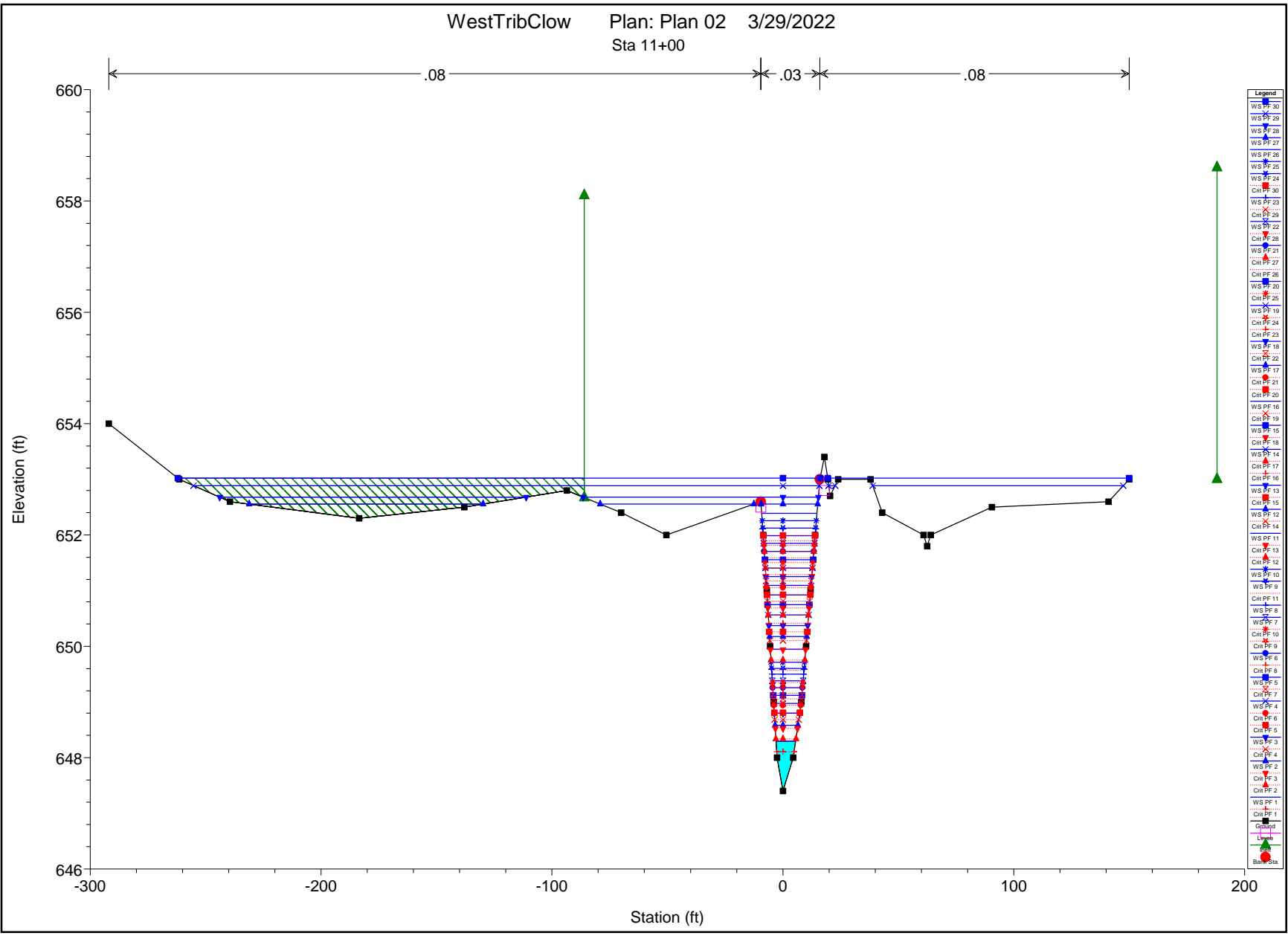

westTribClow.rep

HEC-RAS Version 4.1.0 Jan 2010
U.S. Army Corps of Engineers
Hydrologic Engineering Center
609 Second Street
Davis, California

```
X      X  XXXXXX      XXXX      XXXX      XX      XXXX
X      X  X          X      X      X      X      X
X      X  X          X          X      X      X      X
XXXXXXXX XXXX      X          XXX XXXX      XXXXXX      XXXX
X      X  X          X          X      X      X          X
X      X  X          X      X      X      X      X
X      X  XXXXXX      XXXX      X      X      X      X      XXXXX
```

PROJECT DATA

Project Title: westTribClow
Project File : westTribClow.prj
Run Date and Time: 3/29/2022 4:24:17 PM

Project in English units

Project Description:
West Tributary of Clow Creek
3-16-2022 MAM/

PLAN DATA

Plan Title: Plan 02
Plan File : l:\904411\Hydro\HECRAS\westTribClow.p02

Geometry Title: ModExist
Geometry File : l:\904411\Hydro\HECRAS\westTribClow.g01

Flow Title : Rating
Flow File : l:\904411\Hydro\HECRAS\westTribClow.f02

Plan Summary Information:

Number of:	Cross Sections =	10	Multiple Openings =	0
	Culverts =	1	Inline Structures =	0
	Bridges =	0	Lateral Structures =	0

Computational Information

Water surface calculation tolerance =	0.01
Critical depth calculation tolerance =	0.01
Maximum number of iterations =	20
Maximum difference tolerance =	0.3
Flow tolerance factor =	0.001

Computation Options

Critical depth computed only where necessary
Conveyance Calculation Method: At breaks in n values only
Friction Slope Method: Average Conveyance
Computational Flow Regime: Subcritical Flow

westTribClow.rep

FLOW DATA

Flow Title: Rating
 Flow File : I:\904411\Hydro\HECRAS\westTribClow.f02

Flow Data (cfs)

River PF 3	Reach PF 4	RS PF 5	PF 6	PF 1	PF 7	PF 2	PF
8 westTribClow 30	westTribClow 40	1811 50	60	10	70	20	
80							

River PF 11	Reach PF 12	RS PF 13	PF 14	PF 9	PF 15	PF 10	PF
16 westTribClow 125	westTribClow 150	1811 175	200	90	225	100	
250							

Boundary Conditions

River Downstream	Reach	Profile	Upstream
WestTribClow	WestTribClow	PF 1	
Normal S = 0.02			
WestTribClow	WestTribClow	PF 2	
Normal S = 0.02			
WestTribClow	WestTribClow	PF 3	
Normal S = 0.02			
WestTribClow	WestTribClow	PF 4	
Normal S = 0.02			
WestTribClow	WestTribClow	PF 5	
Normal S = 0.02			
WestTribClow	WestTribClow	PF 6	
Normal S = 0.02			
WestTribClow	WestTribClow	PF 7	
Normal S = 0.02			
WestTribClow	WestTribClow	PF 8	
Normal S = 0.02			
WestTribClow	WestTribClow	PF 9	
Normal S = 0.02			
WestTribClow	WestTribClow	PF 10	
Normal S = 0.02			
WestTribClow	WestTribClow	PF 11	
Normal S = 0.02			

```

WestTribClow      WestTribClow      WestTribClow.rep
Normal S = 0.02   PF 12
WestTribClow      WestTribClow      PF 13
Normal S = 0.02   PF 14
WestTribClow      WestTribClow      PF 15
Normal S = 0.02   PF 16
WestTribClow      WestTribClow      PF 17
Normal S = 0.02   PF 18
WestTribClow      WestTribClow      PF 19
Normal S = 0.02   PF 20
WestTribClow      WestTribClow      PF 21
Normal S = 0.02   PF 22
WestTribClow      WestTribClow
Normal S = 0.02

```

GEOMETRY DATA

Geometry Title: ModExist
 Geometry File : I:\904411\Hydro\HECRAS\WestTribClow.g01

CROSS SECTION

RIVER: WestTribClow
 REACH: WestTribClow RS: 1811

INPUT

Description: Sta: 18+11

Station Elevation Data		num= 10		Sta	Elev	Sta	Elev	Sta	Elev
-77	658.8	-50	658.4	-22	658	-6.5	658	-6	651.1
0	651.1	6	651.1	6.5	658	13	658.6	29	659

Manning's n Values		num= 3		Sta	n Val	Sta	n Val
-77	.08	-6.5	.03	6.5	.08		

Bank Sta:	Left	Right	Lengths:	Left Channel	Right	Coeff Contr.	Expan.
	-6.5	6.5		34	34	.1	.3

Ineffective Flow		num= 2		Sta L	Sta R	Elev	Permanent
-77	-6.5	658.5	F	6.5	29	659	T

CROSS SECTION OUTPUT Profile #PF 1

E.G. Elev (ft)	651.54	Element	Left OB	Channel
Right OB				
Vel Head (ft)	0.09	wt. n-Val.		0.030

westTribClow.rep				
W.S. Elev (ft)	651.45	Reach Len. (ft)	34.00	34.00
34.00				
Crit w.s. (ft)	651.38	Flow Area (sq ft)		4.21
E.G. Slope (ft/ft)	0.010049	Area (sq ft)		4.21
Q Total (cfs)	10.00	Flow (cfs)		10.00
Top width (ft)	12.05	Top width (ft)		12.05
Vel Total (ft/s)	2.38	Avg. Vel. (ft/s)		2.38
Max Chl Dpth (ft)	0.35	Hydr. Depth (ft)		0.35
Conv. Total (cfs)	99.8	Conv. (cfs)		99.8
Length wtd. (ft)	34.00	wetted Per. (ft)		12.70
Min ch El (ft)	651.10	Shear (lb/sq ft)		0.21
Alpha	1.00	Stream Power (lb/ft s)	29.00	0.00
0.00				
Frctn Loss (ft)		Cum Volume (acre-ft)		0.10
C & E Loss (ft)		Cum SA (acres)		0.20

Note: Multiple critical depths were found at this location. The critical depth with the lowest, valid, energy was used.

CROSS SECTION OUTPUT Profile #PF 2

E.G. Elev (ft)	651.81	Element	Left OB	Channel
Right OB				
Vel Head (ft)	0.13	wt. n-Val.		0.030
W.S. Elev (ft)	651.68	Reach Len. (ft)	34.00	34.00
34.00				
Crit w.s. (ft)	651.55	Flow Area (sq ft)		6.96
E.G. Slope (ft/ft)	0.007876	Area (sq ft)		6.96
Q Total (cfs)	20.00	Flow (cfs)		20.00
Top width (ft)	12.08	Top width (ft)		12.08
Vel Total (ft/s)	2.87	Avg. Vel. (ft/s)		2.87
Max Chl Dpth (ft)	0.58	Hydr. Depth (ft)		0.58
Conv. Total (cfs)	225.4	Conv. (cfs)		225.4
Length wtd. (ft)	34.00	wetted Per. (ft)		13.16
Min ch El (ft)	651.10	Shear (lb/sq ft)		0.26
Alpha	1.00	Stream Power (lb/ft s)	29.00	0.00
0.00				
Frctn Loss (ft)		Cum Volume (acre-ft)		0.17

C & E Loss (ft)

WestTribClow.rep
Cum SA (acres)

0.24

Note: Multiple critical depths were found at this location. The critical depth with the lowest, valid, energy was used.

CROSS SECTION OUTPUT Profile #PF 3

E.G. Elev (ft)	652.03	Element	Left OB	Channel
Right OB Vel Head (ft)	0.17	wt. n-val.		0.030
W.S. Elev (ft)	651.86	Reach Len. (ft)	34.00	34.00
34.00 Crit w.s. (ft)	651.68	Flow Area (sq ft)		9.13
E.G. Slope (ft/ft)	0.007423	Area (sq ft)		9.13
Q Total (cfs)	30.00	Flow (cfs)		30.00
Top width (ft)	12.11	Top width (ft)		12.11
Vel Total (ft/s)	3.29	Avg. vel. (ft/s)		3.29
Max chl Dpth (ft)	0.76	Hydr. Depth (ft)		0.75
Conv. Total (cfs)	348.2	Conv. (cfs)		348.2
Length wtd. (ft)	34.00	wetted Per. (ft)		13.52
Min ch El (ft)	651.10	Shear (lb/sq ft)		0.31
Alpha	1.00	Stream Power (lb/ft s)	29.00	0.00
0.00 Frctn Loss (ft)		Cum Volume (acre-ft)		0.23
C & E Loss (ft)		Cum SA (acres)		0.27

Note: Multiple critical depths were found at this location. The critical depth with the lowest, valid, energy was used.

CROSS SECTION OUTPUT Profile #PF 4

E.G. Elev (ft)	652.22	Element	Left OB	Channel
Right OB Vel Head (ft)	0.20	wt. n-val.		0.030
W.S. Elev (ft)	652.02	Reach Len. (ft)	34.00	34.00
34.00 Crit w.s. (ft)	651.80	Flow Area (sq ft)		11.08
E.G. Slope (ft/ft)	0.007140	Area (sq ft)		11.08
Q Total (cfs)	40.00	Flow (cfs)		40.00
Top width (ft)	12.13	Top width (ft)		12.13

westTribClow.rep

Vel Total (ft/s)	3.61	Avg. Vel. (ft/s)		3.61
Max Chl Dpth (ft)	0.92	Hydr. Depth (ft)		0.91
Conv. Total (cfs)	473.4	Conv. (cfs)		473.4
Length Wtd. (ft)	34.00	wetted Per. (ft)		13.84
Min Ch El (ft)	651.10	Shear (lb/sq ft)		0.36
Alpha	1.00	Stream Power (lb/ft s)	29.00	0.00
0.00		Cum Volume (acre-ft)		0.29
Frctn Loss (ft)		Cum SA (acres)		0.29
C & E Loss (ft)				

Note: Multiple critical depths were found at this location. The critical depth with the lowest, valid, energy was used.

CROSS SECTION OUTPUT Profile #PF 5

E.G. Elev (ft)	652.40	Element	Left OB	Channel
Right OB				
Vel Head (ft)	0.23	wt. n-Val.		0.030
w.s. Elev (ft)	652.17	Reach Len. (ft)	34.00	34.00
34.00				
Crit w.s. (ft)	651.91	Flow Area (sq ft)		12.88
E.G. Slope (ft/ft)	0.006954	Area (sq ft)		12.88
Q Total (cfs)	50.00	Flow (cfs)		50.00
Top width (ft)	12.15	Top width (ft)		12.15
Vel Total (ft/s)	3.88	Avg. Vel. (ft/s)		3.88
Max Chl Dpth (ft)	1.07	Hydr. Depth (ft)		1.06
Conv. Total (cfs)	599.6	Conv. (cfs)		599.6
Length Wtd. (ft)	34.00	wetted Per. (ft)		14.14
Min Ch El (ft)	651.10	Shear (lb/sq ft)		0.40
Alpha	1.00	Stream Power (lb/ft s)	29.00	0.00
0.00		Cum Volume (acre-ft)		0.34
Frctn Loss (ft)		Cum SA (acres)		0.31
C & E Loss (ft)				

Note: Multiple critical depths were found at this location. The critical depth with the lowest, valid, energy was used.

CROSS SECTION OUTPUT Profile #PF 6

WestTribClow.rep

E.G. Elev (ft)	652.57	Element	Left OB	Channel
Right OB Vel Head (ft)	0.26	wt. n-val.		0.030
W.S. Elev (ft)	652.31	Reach Len. (ft)	34.00	34.00
34.00 Crit w.s. (ft)	652.01	Flow Area (sq ft)		14.57
E.G. Slope (ft/ft)	0.006823	Area (sq ft)		14.57
Q Total (cfs)	60.00	Flow (cfs)		60.00
Top width (ft)	12.17	Top width (ft)		12.17
Vel Total (ft/s)	4.12	Avg. Vel. (ft/s)		4.12
Max chl Dpth (ft)	1.21	Hydr. Depth (ft)		1.20
Conv. Total (cfs)	726.4	Conv. (cfs)		726.4
Length wtd. (ft)	34.00	wetted Per. (ft)		14.42
Min ch El (ft)	651.10	Shear (lb/sq ft)		0.43
Alpha 0.00	1.00	Stream Power (lb/ft s)	29.00	0.00
Frctn Loss (ft)		Cum Volume (acre-ft)		0.39
C & E Loss (ft)		Cum SA (acres)		0.32

Note: Multiple critical depths were found at this location. The critical depth with the lowest, valid, energy was used.

CROSS SECTION OUTPUT Profile #PF 7

E.G. Elev (ft)	652.73	Element	Left OB	Channel
Right OB Vel Head (ft)	0.29	wt. n-val.		0.030
W.S. Elev (ft)	652.44	Reach Len. (ft)	34.00	34.00
34.00 Crit w.s. (ft)	652.12	Flow Area (sq ft)		16.17
E.G. Slope (ft/ft)	0.006718	Area (sq ft)		16.17
Q Total (cfs)	70.00	Flow (cfs)		70.00
Top width (ft)	12.19	Top width (ft)		12.19
Vel Total (ft/s)	4.33	Avg. Vel. (ft/s)		4.33
Max chl Dpth (ft)	1.34	Hydr. Depth (ft)		1.33
Conv. Total (cfs)	854.0	Conv. (cfs)		854.0
Length wtd. (ft)	34.00	wetted Per. (ft)		14.68

Min Ch El (ft)	651.10	westTribCflow.rep Shear (lb/sq ft)		0.46
Alpha 0.00	1.00	Stream Power (lb/ft s)	29.00	0.00
Frctn Loss (ft)		Cum Volume (acre-ft)		0.43
C & E Loss (ft)		Cum SA (acres)		0.33

Note: Multiple critical depths were found at this location. The critical depth with the lowest, valid, energy was used.

CROSS SECTION OUTPUT Profile #PF 8

E.G. Elev (ft)	652.88	Element	Left OB	Channel
Right OB Vel Head (ft)	0.32	wt. n-Val.		0.030
W.S. Elev (ft)	652.56	Reach Len. (ft)	34.00	34.00
34.00 Crit w.s. (ft)	652.21	Flow Area (sq ft)		17.69
E.G. Slope (ft/ft)	0.006643	Area (sq ft)		17.69
Q Total (cfs)	80.00	Flow (cfs)		80.00
Top width (ft)	12.21	Top width (ft)		12.21
Vel Total (ft/s)	4.52	Avg. Vel. (ft/s)		4.52
Max Chl Dpth (ft)	1.46	Hydr. Depth (ft)		1.45
Conv. Total (cfs)	981.5	Conv. (cfs)		981.5
Length wtd. (ft)	34.00	wetted Per. (ft)		14.93
Min Ch El (ft)	651.10	Shear (lb/sq ft)		0.49
Alpha 0.00	1.00	Stream Power (lb/ft s)	29.00	0.00
Frctn Loss (ft)		Cum Volume (acre-ft)		0.47
C & E Loss (ft)		Cum SA (acres)		0.34

Note: Multiple critical depths were found at this location. The critical depth with the lowest, valid, energy was used.

CROSS SECTION OUTPUT Profile #PF 9

E.G. Elev (ft)	653.02	Element	Left OB	Channel
Right OB Vel Head (ft)	0.34	wt. n-Val.		0.030
W.S. Elev (ft)	652.68	Reach Len. (ft)	34.00	34.00
34.00 Crit w.s. (ft)	652.30	Flow Area (sq ft)		19.16
		Page 8		

westTribClow.rep

E.G. Slope (ft/ft)	0.006584	Area (sq ft)		19.16
Q Total (cfs)	90.00	Flow (cfs)		90.00
Top width (ft)	12.23	Top width (ft)		12.23
Vel Total (ft/s)	4.70	Avg. Vel. (ft/s)		4.70
Max Chl Dpth (ft)	1.58	Hydr. Depth (ft)		1.57
Conv. Total (cfs)	1109.2	Conv. (cfs)		1109.2
Length Wtd. (ft)	34.00	wetted Per. (ft)		15.17
Min Ch El (ft)	651.10	Shear (lb/sq ft)		0.52
Alpha 0.00	1.00	Stream Power (lb/ft s)	29.00	0.00
Frctn Loss (ft)		Cum Volume (acre-ft)		0.51
C & E Loss (ft)		Cum SA (acres)		0.34

Note: Multiple critical depths were found at this location. The critical depth with the lowest, valid, energy was used.

CROSS SECTION OUTPUT Profile #PF 10

E.G. Elev (ft)	653.16	Element	Left OB	Channel
Right OB Vel Head (ft)	0.37	wt. n-Val.		0.030
w.s. Elev (ft)	652.80	Reach Len. (ft)	34.00	34.00
34.00 Crit w.s. (ft)	652.38	Flow Area (sq ft)		20.58
E.G. Slope (ft/ft)	0.006537	Area (sq ft)		20.58
Q Total (cfs)	100.00	Flow (cfs)		100.00
Top width (ft)	12.25	Top width (ft)		12.25
Vel Total (ft/s)	4.86	Avg. Vel. (ft/s)		4.86
Max Chl Dpth (ft)	1.70	Hydr. Depth (ft)		1.68
Conv. Total (cfs)	1236.8	Conv. (cfs)		1236.8
Length Wtd. (ft)	34.00	wetted Per. (ft)		15.40
Min Ch El (ft)	651.10	Shear (lb/sq ft)		0.55
Alpha 0.00	1.00	Stream Power (lb/ft s)	29.00	0.00
Frctn Loss (ft)		Cum Volume (acre-ft)		0.55
C & E Loss (ft)		Cum SA (acres)		0.35

WestTribClow.rep

Note: Multiple critical depths were found at this location. The critical depth with the lowest, valid, energy was used.

CROSS SECTION OUTPUT Profile #PF 11

E.G. Elev (ft)	653.50	Element	Left OB	Channel
Right OB Vel Head (ft)	0.42	wt. n-val.		0.030
W.S. Elev (ft)	653.07	Reach Len. (ft)	34.00	34.00
34.00 Crit w.s. (ft)	652.60	Flow Area (sq ft)		23.96
E.G. Slope (ft/ft)	0.006452	Area (sq ft)		23.96
Q Total (cfs)	125.00	Flow (cfs)		125.00
Top width (ft)	12.29	Top width (ft)		12.29
Vel Total (ft/s)	5.22	Avg. Vel. (ft/s)		5.22
Max chl Dpth (ft)	1.97	Hydr. Depth (ft)		1.95
Conv. Total (cfs)	1556.2	Conv. (cfs)		1556.2
Length wtd. (ft)	34.00	wetted Per. (ft)		15.96
Min ch El (ft)	651.10	Shear (lb/sq ft)		0.60
Alpha 0.00	1.00	Stream Power (lb/ft s)	29.00	0.00
Frctn Loss (ft)		Cum Volume (acre-ft)		0.64
C & E Loss (ft)		Cum SA (acres)		0.37

Note: Multiple critical depths were found at this location. The critical depth with the lowest, valid, energy was used.

CROSS SECTION OUTPUT Profile #PF 12

E.G. Elev (ft)	653.81	Element	Left OB	Channel
Right OB Vel Head (ft)	0.47	wt. n-val.		0.030
W.S. Elev (ft)	653.33	Reach Len. (ft)	34.00	34.00
34.00 Crit w.s. (ft)	652.79	Flow Area (sq ft)		27.13
E.G. Slope (ft/ft)	0.006406	Area (sq ft)		27.13
Q Total (cfs)	150.00	Flow (cfs)		150.00
Top width (ft)	12.32	Top width (ft)		12.32
Vel Total (ft/s)	5.53	Avg. Vel. (ft/s)		5.53

	westTribClow.rep		
Max Chl Dpth (ft)	2.23	Hydr. Depth (ft)	2.20
Conv. Total (cfs)	1874.1	Conv. (cfs)	1874.1
Length Wtd. (ft)	34.00	wetted Per. (ft)	16.47
Min Ch El (ft)	651.10	Shear (lb/sq ft)	0.66
Alpha 0.00	1.00	Stream Power (lb/ft s)	29.00
Frctn Loss (ft)		Cum Volume (acre-ft)	0.73
C & E Loss (ft)		Cum SA (acres)	0.38

Note: Multiple critical depths were found at this location. The critical depth with the lowest, valid, energy was used.

CROSS SECTION OUTPUT Profile #PF 13

		Element	Left OB	Channel
E.G. Elev (ft)	654.10			
Right OB Vel Head (ft)	0.52	wt. n-val.		0.030
w.s. Elev (ft)	653.57	Reach Len. (ft)	34.00	34.00
34.00 Crit w.s. (ft)	652.97	Flow Area (sq ft)		30.14
E.G. Slope (ft/ft)	0.006383	Area (sq ft)		30.14
Q Total (cfs)	175.00	Flow (cfs)		175.00
Top width (ft)	12.36	Top width (ft)		12.36
Vel Total (ft/s)	5.81	Avg. Vel. (ft/s)		5.81
Max Chl Dpth (ft)	2.47	Hydr. Depth (ft)		2.44
Conv. Total (cfs)	2190.4	Conv. (cfs)		2190.4
Length Wtd. (ft)	34.00	wetted Per. (ft)		16.96
Min Ch El (ft)	651.10	Shear (lb/sq ft)		0.71
Alpha 0.00	1.00	Stream Power (lb/ft s)	29.00	0.00
Frctn Loss (ft)		Cum Volume (acre-ft)		0.81
C & E Loss (ft)		Cum SA (acres)		0.39

Note: Multiple critical depths were found at this location. The critical depth with the lowest, valid, energy was used.

CROSS SECTION OUTPUT Profile #PF 14

E.G. Elev (ft)	654.38	Element	Left OB	Channel
		Page 11		

westTribClow.rep

Right OB				
Vel Head (ft)	0.57	Wt. n-val.		0.030
W.S. Elev (ft)	653.81	Reach Len. (ft)	34.00	34.00
34.00				
Crit w.s. (ft)	653.14	Flow Area (sq ft)		33.03
E.G. Slope (ft/ft)	0.006373	Area (sq ft)		33.03
Q Total (cfs)	200.00	Flow (cfs)		200.00
Top width (ft)	12.39	Top width (ft)		12.39
Vel Total (ft/s)	6.06	Avg. Vel. (ft/s)		6.06
Max Chl Dpth (ft)	2.71	Hydr. Depth (ft)		2.67
Conv. Total (cfs)	2505.3	Conv. (cfs)		2505.3
Length wtd. (ft)	34.00	wetted Per. (ft)		17.43
Min ch El (ft)	651.10	Shear (lb/sq ft)		0.75
Alpha	1.00	Stream Power (lb/ft s)	29.00	0.00
0.00				
Frctn Loss (ft)		Cum Volume (acre-ft)		0.89
C & E Loss (ft)		Cum SA (acres)		0.40

Note: Multiple critical depths were found at this location. The critical depth with the lowest, valid, energy was used.

CROSS SECTION OUTPUT Profile #PF 15

E.G. Elev (ft)	654.65	Element	Left OB	Channel
Right OB				
Vel Head (ft)	0.61	Wt. n-val.		0.030
W.S. Elev (ft)	654.03	Reach Len. (ft)	34.00	34.00
34.00				
Crit w.s. (ft)	653.31	Flow Area (sq ft)		35.81
E.G. Slope (ft/ft)	0.006373	Area (sq ft)		35.81
Q Total (cfs)	225.00	Flow (cfs)		225.00
Top width (ft)	12.43	Top width (ft)		12.43
Vel Total (ft/s)	6.28	Avg. Vel. (ft/s)		6.28
Max Chl Dpth (ft)	2.93	Hydr. Depth (ft)		2.88
Conv. Total (cfs)	2818.6	Conv. (cfs)		2818.6
Length wtd. (ft)	34.00	wetted Per. (ft)		17.88
Min ch El (ft)	651.10	Shear (lb/sq ft)		0.80
Alpha	1.00	Stream Power (lb/ft s)	29.00	0.00

WestTribClow.rep

0.00			
Frctn Loss (ft)		Cum Volume (acre-ft)	0.97
C & E Loss (ft)		Cum SA (acres)	0.42

Note: Multiple critical depths were found at this location. The critical depth with the lowest, valid, energy was used.

CROSS SECTION OUTPUT Profile #PF 16

E.G. Elev (ft)	654.90	Element	Left OB	Channel
Right OB				
Vel Head (ft)	0.65	wt. n-val.		0.030
W.S. Elev (ft)	654.25	Reach Len. (ft)	34.00	34.00
34.00				
Crit w.s. (ft)	653.46	Flow Area (sq ft)		38.50
E.G. Slope (ft/ft)	0.006381	Area (sq ft)		38.50
Q Total (cfs)	250.00	Flow (cfs)		250.00
Top width (ft)	12.46	Top width (ft)		12.46
Vel Total (ft/s)	6.49	Avg. Vel. (ft/s)		6.49
Max Chl Dpth (ft)	3.15	Hydr. Depth (ft)		3.09
Conv. Total (cfs)	3129.7	Conv. (cfs)		3129.7
Length wtd. (ft)	34.00	wetted Per. (ft)		18.31
Min Ch El (ft)	651.10	Shear (lb/sq ft)		0.84
Alpha	1.00	Stream Power (lb/ft s)	29.00	0.00
0.00				
Frctn Loss (ft)		Cum Volume (acre-ft)		1.05
C & E Loss (ft)		Cum SA (acres)		0.43

Note: Multiple critical depths were found at this location. The critical depth with the lowest, valid, energy was used.

CROSS SECTION OUTPUT Profile #PF 17

E.G. Elev (ft)	655.15	Element	Left OB	Channel
Right OB				
Vel Head (ft)	0.69	wt. n-val.		0.030
W.S. Elev (ft)	654.46	Reach Len. (ft)	34.00	34.00
34.00				
Crit w.s. (ft)	653.63	Flow Area (sq ft)		41.12
E.G. Slope (ft/ft)	0.006390	Area (sq ft)		41.12

westTribClow.rep				
Q Total (cfs)	275.00	Flow (cfs)		275.00
Top width (ft)	12.49	Top width (ft)		12.49
Vel Total (ft/s)	6.69	Avg. Vel. (ft/s)		6.69
Max Chl Dpth (ft)	3.36	Hydr. Depth (ft)		3.29
Conv. Total (cfs)	3440.1	Conv. (cfs)		3440.1
Length wtd. (ft)	34.00	wetted Per. (ft)		18.74
Min Ch El (ft)	651.10	Shear (lb/sq ft)		0.88
Alpha 0.00	1.00	Stream Power (lb/ft s)	29.00	0.00
Frctn Loss (ft)		Cum Volume (acre-ft)		1.12
C & E Loss (ft)		Cum SA (acres)		0.44

Note: Multiple critical depths were found at this location. The critical depth with the lowest, valid, energy was used.

CROSS SECTION OUTPUT Profile #PF 18

Right OB				
E.G. Elev (ft)	655.40	Element	Left OB	Channel
Vel Head (ft)	0.73	wt. n-Val.		0.030
w.s. Elev (ft)	654.66	Reach Len. (ft)	34.00	34.00
34.00 Crit w.s. (ft)	653.77	Flow Area (sq ft)		43.67
E.G. Slope (ft/ft)	0.006408	Area (sq ft)		43.67
Q Total (cfs)	300.00	Flow (cfs)		300.00
Top width (ft)	12.52	Top width (ft)		12.52
Vel Total (ft/s)	6.87	Avg. Vel. (ft/s)		6.87
Max Chl Dpth (ft)	3.56	Hydr. Depth (ft)		3.49
Conv. Total (cfs)	3747.7	Conv. (cfs)		3747.7
Length wtd. (ft)	34.00	wetted Per. (ft)		19.14
Min Ch El (ft)	651.10	Shear (lb/sq ft)		0.91
Alpha 0.00	1.00	Stream Power (lb/ft s)	29.00	0.00
Frctn Loss (ft)		Cum Volume (acre-ft)		1.19
C & E Loss (ft)		Cum SA (acres)		0.45

Note: Multiple critical depths were found at this location. The critical depth
Page 14

with the lowest, valid, energy was used.

CROSS SECTION OUTPUT Profile #PF 19

E.G. Elev (ft)	655.63	Element	Left OB	Channel
Right OB Vel Head (ft)	0.77	wt. n-val.		0.030
W.S. Elev (ft)	654.86	Reach Len. (ft)	34.00	34.00
34.00 Crit w.s. (ft)	653.93	Flow Area (sq ft)		46.16
E.G. Slope (ft/ft)	0.006425	Area (sq ft)		46.16
Q Total (cfs)	325.00	Flow (cfs)		325.00
Top width (ft)	12.55	Top width (ft)		12.55
Vel Total (ft/s)	7.04	Avg. vel. (ft/s)		7.04
Max chl Dpth (ft)	3.76	Hydr. Depth (ft)		3.68
Conv. Total (cfs)	4054.5	Conv. (cfs)		4054.5
Length wtd. (ft)	34.00	wetted Per. (ft)		19.54
Min ch El (ft)	651.10	Shear (lb/sq ft)		0.95
Alpha 0.00	1.00	Stream Power (lb/ft s)	29.00	0.00
Frctn Loss (ft)		Cum Volume (acre-ft)	0.00	1.26
0.00 C & E Loss (ft)		Cum SA (acres)	0.00	0.46
0.00				

Note: Multiple critical depths were found at this location. The critical depth with the lowest, valid, energy was used.

CROSS SECTION OUTPUT Profile #PF 20

E.G. Elev (ft)	655.86	Element	Left OB	Channel
Right OB Vel Head (ft)	0.81	wt. n-val.		0.030
W.S. Elev (ft)	655.05	Reach Len. (ft)	34.00	34.00
34.00 Crit w.s. (ft)	654.06	Flow Area (sq ft)		48.59
E.G. Slope (ft/ft)	0.006447	Area (sq ft)		48.59
Q Total (cfs)	350.00	Flow (cfs)		350.00
Top width (ft)	12.57	Top width (ft)		12.57
Vel Total (ft/s)	7.20	Avg. vel. (ft/s)		7.20
Max chl Dpth (ft)	3.95	Hydr. Depth (ft)		3.86
Conv. Total (cfs)	4359.2	Conv. (cfs)		4359.2

westTribCflow.rep

Length Wtd. (ft)	34.00	Wetted Per. (ft)		19.93
Min Ch El (ft)	651.10	Shear (lb/sq ft)		0.98
Alpha	1.00	Stream Power (lb/ft s)	29.00	0.00
0.00				
Frctn Loss (ft)		Cum Volume (acre-ft)	0.00	1.33
0.00				
C & E Loss (ft)		Cum SA (acres)	0.00	0.46
0.01				

Note: Multiple critical depths were found at this location. The critical depth with the lowest, valid, energy was used.

CROSS SECTION OUTPUT Profile #PF 21

E.G. Elev (ft)	656.08	Element	Left OB	Channel
Right OB				
Vel Head (ft)	0.84	wt. n-Val.		0.030
W.S. Elev (ft)	655.24	Reach Len. (ft)	34.00	34.00
34.00				
Crit w.s. (ft)	654.20	Flow Area (sq ft)		50.97
E.G. Slope (ft/ft)	0.006469	Area (sq ft)		50.97
Q Total (cfs)	375.00	Flow (cfs)		375.00
Top width (ft)	12.60	Top width (ft)		12.60
Vel Total (ft/s)	7.36	Avg. Vel. (ft/s)		7.36
Max Chl Dpth (ft)	4.14	Hydr. Depth (ft)		4.05
Conv. Total (cfs)	4662.3	Conv. (cfs)		4662.3
Length Wtd. (ft)	34.00	wetted Per. (ft)		20.31
Min Ch El (ft)	651.10	Shear (lb/sq ft)		1.01
Alpha	1.00	Stream Power (lb/ft s)	29.00	0.00
0.00				
Frctn Loss (ft)		Cum Volume (acre-ft)	0.00	1.40
0.00				
C & E Loss (ft)		Cum SA (acres)	0.00	0.47
0.01				

Note: Multiple critical depths were found at this location. The critical depth with the lowest, valid, energy was used.

CROSS SECTION OUTPUT Profile #PF 22

E.G. Elev (ft)	656.30	Element	Left OB	Channel
Right OB				
Vel Head (ft)	0.87	wt. n-Val.		0.030

westTribClow.rep				
W.S. Elev (ft)	655.43	Reach Len. (ft)	34.00	34.00
34.00				
Crit w.s. (ft)	654.34	Flow Area (sq ft)		53.31
E.G. Slope (ft/ft)	0.006493	Area (sq ft)		53.31
Q Total (cfs)	400.00	Flow (cfs)		400.00
Top width (ft)	12.63	Top width (ft)		12.63
Vel Total (ft/s)	7.50	Avg. Vel. (ft/s)		7.50
Max Chl Dpth (ft)	4.33	Hydr. Depth (ft)		4.22
Conv. Total (cfs)	4964.2	Conv. (cfs)		4964.2
Length wtd. (ft)	34.00	wetted Per. (ft)		20.68
Min ch El (ft)	651.10	Shear (lb/sq ft)		1.04
Alpha	1.00	Stream Power (lb/ft s)	29.00	0.00
0.00				
Frctn Loss (ft)		Cum Volume (acre-ft)	0.00	1.47
0.00				
C & E Loss (ft)		Cum SA (acres)	0.00	0.48
0.01				

Note: Multiple critical depths were found at this location. The critical depth with the lowest, valid, energy was used.

CROSS SECTION OUTPUT Profile #PF 23

Right OB				
E.G. Elev (ft)	656.52	Element	Left OB	Channel
Vel Head (ft)	0.91	wt. n-Val.		0.030
W.S. Elev (ft)	655.61	Reach Len. (ft)	34.00	34.00
34.00				
Crit w.s. (ft)	654.47	Flow Area (sq ft)		55.61
E.G. Slope (ft/ft)	0.006517	Area (sq ft)		55.61
Q Total (cfs)	425.00	Flow (cfs)		425.00
Top width (ft)	12.65	Top width (ft)		12.65
Vel Total (ft/s)	7.64	Avg. Vel. (ft/s)		7.64
Max Chl Dpth (ft)	4.51	Hydr. Depth (ft)		4.39
Conv. Total (cfs)	5264.5	Conv. (cfs)		5264.5
Length wtd. (ft)	34.00	wetted Per. (ft)		21.05
Min ch El (ft)	651.10	Shear (lb/sq ft)		1.08
Alpha	1.00	Stream Power (lb/ft s)	29.00	0.00
0.00				
Frctn Loss (ft)		Cum Volume (acre-ft)	0.00	1.53
0.01				

C & E Loss (ft)	0.02	WestTribClow.rep Cum SA (acres)	0.00	0.49
-----------------	------	------------------------------------	------	------

Note: Multiple critical depths were found at this location. The critical depth with the lowest, valid, energy was used.

CROSS SECTION OUTPUT Profile #PF 24

E.G. Elev (ft)	656.73	Element	Left OB	Channel
Right OB Vel Head (ft)	0.94	wt. n-val.		0.030
W.S. Elev (ft)	655.80	Reach Len. (ft)	34.00	34.00
34.00 Crit w.s. (ft)	654.57	Flow Area (sq ft)		57.98
E.G. Slope (ft/ft)	0.006511	Area (sq ft)		57.98
Q Total (cfs)	450.00	Flow (cfs)		450.00
Top width (ft)	12.68	Top width (ft)		12.68
Vel Total (ft/s)	7.76	Avg. vel. (ft/s)		7.76
Max chl Dpth (ft)	4.70	Hydr. Depth (ft)		4.57
Conv. Total (cfs)	5576.9	Conv. (cfs)		5576.9
Length wtd. (ft)	34.00	wetted Per. (ft)		21.42
Min ch El (ft)	651.10	Shear (lb/sq ft)		1.10
Alpha	1.00	Stream Power (lb/ft s)	29.00	0.00
0.00 Frctn Loss (ft)		Cum Volume (acre-ft)	0.15	1.60
0.01 C & E Loss (ft)		Cum SA (acres)	0.35	0.49
0.02				

Note: Multiple critical depths were found at this location. The critical depth with the lowest, valid, energy was used.

CROSS SECTION OUTPUT Profile #PF 25

E.G. Elev (ft)	656.95	Element	Left OB	Channel
Right OB Vel Head (ft)	0.96	wt. n-val.		0.030
W.S. Elev (ft)	655.99	Reach Len. (ft)	34.00	34.00
34.00 Crit w.s. (ft)	654.72	Flow Area (sq ft)		60.41
E.G. Slope (ft/ft)	0.006476	Area (sq ft)		60.41
Q Total (cfs)	475.00	Flow (cfs)		475.00
Top width (ft)	12.71	Top width (ft)		12.71

westTribClow.rep

Vel Total (ft/s)	7.86	Avg. Vel. (ft/s)		7.86
Max Chl Dpth (ft)	4.89	Hydr. Depth (ft)		4.75
Conv. Total (cfs)	5902.6	Conv. (cfs)		5902.6
Length Wtd. (ft)	34.00	wetted Per. (ft)		21.81
Min Ch El (ft)	651.10	Shear (lb/sq ft)		1.12
Alpha 0.00	1.00	Stream Power (lb/ft s)	29.00	0.00
Frctn Loss (ft) 0.03		Cum Volume (acre-ft)	0.26	1.65
C & E Loss (ft) 0.17		Cum SA (acres)	0.58	0.50

Note: Multiple critical depths were found at this location. The critical depth with the lowest, valid, energy was used.

CROSS SECTION OUTPUT Profile #PF 26

E.G. Elev (ft)	657.16	Element	Left OB	Channel
Right OB Vel Head (ft)	0.98	wt. n-Val.		0.030
w.s. Elev (ft)	656.18	Reach Len. (ft)	34.00	34.00
34.00 Crit w.s. (ft)	654.86	Flow Area (sq ft)		62.82
E.G. Slope (ft/ft)	0.006447	Area (sq ft)		62.82
Q Total (cfs)	500.00	Flow (cfs)		500.00
Top width (ft)	12.74	Top width (ft)		12.74
Vel Total (ft/s)	7.96	Avg. Vel. (ft/s)		7.96
Max Chl Dpth (ft)	5.08	Hydr. Depth (ft)		4.93
Conv. Total (cfs)	6227.2	Conv. (cfs)		6227.2
Length Wtd. (ft)	34.00	wetted Per. (ft)		22.18
Min Ch El (ft)	651.10	Shear (lb/sq ft)		1.14
Alpha 0.00	1.00	Stream Power (lb/ft s)	29.00	0.00
Frctn Loss (ft) 0.20		Cum Volume (acre-ft)	0.35	1.70
C & E Loss (ft) 0.56		Cum SA (acres)	0.66	0.50

Note: Multiple critical depths were found at this location. The critical depth with the lowest, valid, energy was used.

CROSS SECTION OUTPUT Profile #PF 27

westTribClow.rep

E.G. Elev (ft)	657.37	Element	Left OB	Channel
Right OB Vel Head (ft)	1.01	wt. n-val.		0.030
W.S. Elev (ft)	656.37	Reach Len. (ft)	34.00	34.00
34.00 Crit w.s. (ft)	654.98	Flow Area (sq ft)		65.19
E.G. Slope (ft/ft)	0.006422	Area (sq ft)		65.19
Q Total (cfs)	525.00	Flow (cfs)		525.00
Top width (ft)	12.76	Top width (ft)		12.76
Vel Total (ft/s)	8.05	Avg. Vel. (ft/s)		8.05
Max chl Dpth (ft)	5.27	Hydr. Depth (ft)		5.11
Conv. Total (cfs)	6551.2	Conv. (cfs)		6551.2
Length wtd. (ft)	34.00	wetted Per. (ft)		22.56
Min ch El (ft)	651.10	Shear (lb/sq ft)		1.16
Alpha 0.00	1.00	Stream Power (lb/ft s)	29.00	0.00
Frctn Loss (ft)		Cum Volume (acre-ft)	0.74	1.75
0.29 C & E Loss (ft)		Cum SA (acres)	1.83	0.51
0.73				

Note: Multiple critical depths were found at this location. The critical depth with the lowest, valid, energy was used.

CROSS SECTION OUTPUT Profile #PF 28

E.G. Elev (ft)	657.58	Element	Left OB	Channel
Right OB Vel Head (ft)	1.03	wt. n-val.		0.030
W.S. Elev (ft)	656.55	Reach Len. (ft)	34.00	34.00
34.00 Crit w.s. (ft)	655.10	Flow Area (sq ft)		67.54
E.G. Slope (ft/ft)	0.006400	Area (sq ft)		67.54
Q Total (cfs)	550.00	Flow (cfs)		550.00
Top width (ft)	12.79	Top width (ft)		12.79
Vel Total (ft/s)	8.14	Avg. Vel. (ft/s)		8.14
Max chl Dpth (ft)	5.45	Hydr. Depth (ft)		5.28
Conv. Total (cfs)	6874.8	Conv. (cfs)		6874.8
Length wtd. (ft)	34.00	wetted Per. (ft)		22.93

westTribClow.rep				
Min Ch El (ft)	651.10	Shear (lb/sq ft)		1.18
Alpha	1.00	Stream Power (lb/ft s)	29.00	0.00
0.00				
Frctn Loss (ft)		Cum volume (acre-ft)	0.94	1.78
0.68				
C & E Loss (ft)		Cum SA (acres)	2.02	0.51
1.22				

Note: Multiple critical depths were found at this location. The critical depth with the lowest, valid, energy was used.

CROSS SECTION OUTPUT Profile #PF 29

Profile #PF 29				
E.G. Elev (ft)	657.78	Element	Left OB	Channel
Right OB				
Vel Head (ft)	1.05	wt. n-val.		0.030
w.s. Elev (ft)	656.73	Reach Len. (ft)	34.00	34.00
34.00				
Crit w.s. (ft)	655.22	Flow Area (sq ft)		69.87
E.G. Slope (ft/ft)	0.006381	Area (sq ft)		69.87
Q Total (cfs)	575.00	Flow (cfs)		575.00
Top width (ft)	12.82	Top width (ft)		12.82
Vel Total (ft/s)	8.23	Avg. vel. (ft/s)		8.23
Max chl Dpth (ft)	5.63	Hydr. Depth (ft)		5.45
Conv. Total (cfs)	7198.3	Conv. (cfs)		7198.3
Length wtd. (ft)	34.00	wetted Per. (ft)		23.29
Min Ch El (ft)	651.10	Shear (lb/sq ft)		1.19
Alpha	1.00	Stream Power (lb/ft s)	29.00	0.00
0.00				
Frctn Loss (ft)		Cum Volume (acre-ft)	1.10	1.81
0.84				
C & E Loss (ft)		Cum SA (acres)	2.09	0.51
1.55				

Note: Multiple critical depths were found at this location. The critical depth with the lowest, valid, energy was used.

CROSS SECTION OUTPUT Profile #PF 30

Profile #PF 30				
E.G. Elev (ft)	657.98	Element	Left OB	Channel
Right OB				
Vel Head (ft)	1.07	wt. n-val.		0.030
w.s. Elev (ft)	656.91	Reach Len. (ft)	34.00	34.00
34.00				
Crit w.s. (ft)	655.33	Flow Area (sq ft)		72.17

WestTribClow.rep

E.G. Slope (ft/ft)	0.006364	Area (sq ft)	72.17
Q Total (cfs)	600.00	Flow (cfs)	600.00
Top width (ft)	12.84	Top width (ft)	12.84
Vel Total (ft/s)	8.31	Avg. Vel. (ft/s)	8.31
Max Chl Dpth (ft)	5.81	Hydr. Depth (ft)	5.62
Conv. Total (cfs)	7520.9	Conv. (cfs)	7520.9
Length Wtd. (ft)	34.00	wetted Per. (ft)	23.65
Min ch El (ft)	651.10	Shear (lb/sq ft)	1.21
Alpha	1.00	Stream Power (lb/ft s)	29.00
0.00		Cum Volume (acre-ft)	1.28
Frctn Loss (ft)		Cum SA (acres)	2.16
0.95			
C & E Loss (ft)			
1.64			

Note: Multiple critical depths were found at this location. The critical depth with the lowest, valid, energy was used.

CULVERT

RIVER: WestTribClow
 REACH: WestTribClow RS: 1800

INPUT

Description: Box Culvert at Golf Cart Crossing (18+00)

Distance from Upstream XS = 7
 Deck/Roadway width = 8.5
 Weir Coefficient = 2.8

Upstream Deck/Roadway Coordinates

num=	6													
Sta	Hi	Cord	Lo	Cord	Sta	Hi	Cord	Lo	Cord	Sta	Hi	Cord	Lo	Cord
-78		658.9		0	-54		658.6		0	-16		659.1		0
0		659.5		0	18		659.1		0	44		659.4		0

Upstream Bridge Cross Section Data

Station	Elevation	Data	num=	10									
Sta	Elev	Sta	Elev	Sta	Elev	Sta	Elev	Sta	Elev	Sta	Elev	Sta	Elev
-77	658.8	-50	658.4	-22	658	-6.5	658	-6	651.1				
0	651.1	6	651.1	6.5	658	13	658.6	29	659				

Manning's n Values

num=	3				
Sta	n Val	Sta	n Val	Sta	n Val
-77	.08	-6.5	.03	6.5	.08

Bank Sta: Left Right Coeff Contr. Expan.
 -6.5 6.5 .1 .3

Ineffective Flow	num=	2	
Sta L	Sta R	Elev	Permanent
-77	-6.5	658.5	F
6.5	29	659	T

Downstream Deck/Roadway Coordinates

num= 7		Coordinates				Coordinates				Coordinates				
Sta	Hi	Cord	Lo	Cord	Sta	Hi	Cord	Lo	Cord	Sta	Hi	Cord	Lo	Cord
-78	658.9		0		-54	658.6		0		-16	659.1		0	
0	659.5		0		18	659.1		0		44	659.4		0	
50	659.4		0											

Downstream Bridge Cross Section Data

Station Elevation Data		num= 11		Station Elevation Data		Station Elevation Data		Station Elevation Data	
Sta	Elev	Sta	Elev	Sta	Elev	Sta	Elev	Sta	Elev
-81	658.9	-58	658.6	-24	658	-17	657	-6.5	658
-6	650.8	0	650.8	6	650.8	6.5	658	22.5	658
46.5	659								

Manning's n Values

num= 3		num= 3		num= 3	
Sta	n Val	Sta	n Val	Sta	n Val
-81	.08	-6.5	.03	6.5	.08

Bank Sta: Left Right Coeff Contr. Expan.
 -6.5 6.5 .1 .3

Ineffective Flow		num= 2		Permanent	
Sta L	Sta R	Elev	Permanent	Permanent	Permanent
-81	-6.5	658.1	F		
6.5	46.5	658.6	F		

Upstream Embankment side slope = 0 horiz. to 1.0 vertical
 Downstream Embankment side slope = 0 horiz. to 1.0 vertical
 Maximum allowable submergence for weir flow = .98
 Elevation at which weir flow begins =
 Energy head used in spillway design =
 Spillway height used in design =
 weir crest shape = Broad Crested

Number of Culverts = 1

Culvert Name Shape Rise Span
 Culvert #1 Box 6 12
 FHWA Chart # 8 - flared wingwalls
 FHWA Scale # 1 - wingwall flared 30 to 75 deg.
 Solution Criteria = Highest U.S. EG
 Culvert Upstrm Dist Length Top n Bottom n Depth Blocked Entrance Loss Coef
 Exit Loss Coef

1	1	22	.013	.013	0	.2
---	---	----	------	------	---	----

Upstream Elevation = 651.1
 Centerline Station = 0
 Downstream Elevation = 650.8
 Centerline Station = 0

CULVERT OUTPUT Profile #PF 1 Culv Group: Culvert #1

Q Culv Group (cfs)	10.00	Culv Full Len (ft)	
# Barrels	1	Culv Vel US (ft/s)	2.99
Q Barrel (cfs)	10.00	Culv Vel DS (ft/s)	4.38
E.G. US. (ft)	651.55	Culv Inv El Up (ft)	651.10
W.S. US. (ft)	651.45	Culv Inv El Dn (ft)	650.80
E.G. DS (ft)	651.22	Culv Frctn Ls (ft)	0.23
W.S. DS (ft)	651.08	Culv Exit Loss (ft)	0.07
Delta EG (ft)	0.33	Culv Entr Loss (ft)	0.03
Delta WS (ft)	0.37	Q Weir (cfs)	
E.G. IC (ft)	651.49	Weir Sta Lft (ft)	
E.G. OC (ft)	651.55	Weir Sta Rgt (ft)	
Culvert Control	Outlet	Weir Submerg	

WestTribFlow.rep

Culv WS Inlet (ft)	651.38	Weir Max Depth (ft)	
Culv WS Outlet (ft)	650.99	Weir Avg Depth (ft)	
Culv Nml Depth (ft)	0.19	Weir Flow Area (sq ft)	
Culv Crt Depth (ft)	0.28	Min El Weir Flow (ft)	658.61

Warning: Since the culvert has supercritical flow, the program should be run in mixed flow in order to check if the cross section

downstream of the culvert has supercritical flow.

Note: During supercritical analysis, the culvert direct step method went to normal depth. The program then assumed normal depth at the outlet.

Note: The flow in the culvert is entirely supercritical.

CULVERT OUTPUT Profile #PF 2 Culv Group: Culvert #1

Q Culv Group (cfs)	20.00	Culv Full Len (ft)	
# Barrels	1	Culv Vel US (ft/s)	3.77
Q Barrel (cfs)	20.00	Culv Vel DS (ft/s)	5.39
E.G. US. (ft)	651.81	Culv Inv El Up (ft)	651.10
W.S. US. (ft)	651.68	Culv Inv El Dn (ft)	650.80
E.G. DS (ft)	651.46	Culv Frctn Ls (ft)	0.20
W.S. DS (ft)	651.24	Culv Exit Loss (ft)	0.10
Delta EG (ft)	0.35	Culv Entr Loss (ft)	0.04
Delta WS (ft)	0.44	Q Weir (cfs)	
E.G. IC (ft)	651.74	Weir Sta Lft (ft)	
E.G. OC (ft)	651.81	Weir Sta Rgt (ft)	
Culvert Control	Outlet	Weir Submerg	
Culv WS Inlet (ft)	651.54	Weir Max Depth (ft)	
Culv WS Outlet (ft)	651.11	Weir Avg Depth (ft)	
Culv Nml Depth (ft)	0.30	Weir Flow Area (sq ft)	
Culv Crt Depth (ft)	0.44	Min El Weir Flow (ft)	658.61

Warning: Since the culvert has supercritical flow, the program should be run in mixed flow in order to check if the cross section

downstream of the culvert has supercritical flow.

Note: The flow in the culvert is entirely supercritical.

CULVERT OUTPUT Profile #PF 3 Culv Group: Culvert #1

Q Culv Group (cfs)	30.00	Culv Full Len (ft)	
# Barrels	1	Culv Vel US (ft/s)	4.32
Q Barrel (cfs)	30.00	Culv Vel DS (ft/s)	6.11
E.G. US. (ft)	652.03	Culv Inv El Up (ft)	651.10
W.S. US. (ft)	651.86	Culv Inv El Dn (ft)	650.80
E.G. DS (ft)	651.67	Culv Frctn Ls (ft)	0.18
W.S. DS (ft)	651.37	Culv Exit Loss (ft)	0.12
Delta EG (ft)	0.36	Culv Entr Loss (ft)	0.06
Delta WS (ft)	0.48	Q Weir (cfs)	
E.G. IC (ft)	651.95	Weir Sta Lft (ft)	
E.G. OC (ft)	652.03	Weir Sta Rgt (ft)	
Culvert Control	Outlet	Weir Submerg	
Culv WS Inlet (ft)	651.68	Weir Max Depth (ft)	
Culv WS Outlet (ft)	651.21	Weir Avg Depth (ft)	
Culv Nml Depth (ft)	0.38	Weir Flow Area (sq ft)	
Culv Crt Depth (ft)	0.58	Min El Weir Flow (ft)	658.61

Warning: Since the culvert has supercritical flow, the program should be run in mixed flow in order to check if the cross section

downstream of the culvert has supercritical flow.

Note: The flow in the culvert is entirely supercritical.

westTribClow.rep

CULVERT OUTPUT Profile #PF 4 Culv Group: Culvert #1

Q Culv Group (cfs)	40.00	Culv Full Len (ft)	
# Barrels	1	Culv Vel US (ft/s)	4.75
Q Barrel (cfs)	40.00	Culv Vel DS (ft/s)	6.67
E.G. US. (ft)	652.22	Culv Inv El Up (ft)	651.10
W.S. US. (ft)	652.02	Culv Inv El Dn (ft)	650.80
E.G. DS (ft)	651.85	Culv Frctn Ls (ft)	0.16
W.S. DS (ft)	651.50	Culv Exit Loss (ft)	0.14
Delta EG (ft)	0.37	Culv Entr Loss (ft)	0.07
Delta WS (ft)	0.52	Q Weir (cfs)	
E.G. IC (ft)	652.15	Weir Sta Lft (ft)	
E.G. OC (ft)	652.22	Weir Sta Rgt (ft)	
Culvert Control	Outlet	Weir Submerg	
Culv WS Inlet (ft)	651.80	Weir Max Depth (ft)	
Culv WS Outlet (ft)	651.30	Weir Avg Depth (ft)	
Culv Nml Depth (ft)	0.45	Weir Flow Area (sq ft)	
Culv Crt Depth (ft)	0.70	Min El Weir Flow (ft)	658.61

Warning: Since the culvert has supercritical flow, the program should be run in mixed flow in order to check if the cross section downstream of the culvert has supercritical flow.

Note: The flow in the culvert is entirely supercritical.

CULVERT OUTPUT Profile #PF 5 Culv Group: Culvert #1

Q Culv Group (cfs)	50.00	Culv Full Len (ft)	
# Barrels	1	Culv Vel US (ft/s)	5.12
Q Barrel (cfs)	50.00	Culv Vel DS (ft/s)	7.10
E.G. US. (ft)	652.40	Culv Inv El Up (ft)	651.10
W.S. US. (ft)	652.17	Culv Inv El Dn (ft)	650.80
E.G. DS (ft)	652.02	Culv Frctn Ls (ft)	0.15
W.S. DS (ft)	651.61	Culv Exit Loss (ft)	0.15
Delta EG (ft)	0.39	Culv Entr Loss (ft)	0.08
Delta WS (ft)	0.56	Q Weir (cfs)	
E.G. IC (ft)	652.32	Weir Sta Lft (ft)	
E.G. OC (ft)	652.40	Weir Sta Rgt (ft)	
Culvert Control	Outlet	Weir Submerg	
Culv WS Inlet (ft)	651.91	Weir Max Depth (ft)	
Culv WS Outlet (ft)	651.39	Weir Avg Depth (ft)	
Culv Nml Depth (ft)	0.51	Weir Flow Area (sq ft)	
Culv Crt Depth (ft)	0.81	Min El Weir Flow (ft)	658.61

Warning: Since the culvert has supercritical flow, the program should be run in mixed flow in order to check if the cross section downstream of the culvert has supercritical flow.

Note: The flow in the culvert is entirely supercritical.

CULVERT OUTPUT Profile #PF 6 Culv Group: Culvert #1

Q Culv Group (cfs)	60.00	Culv Full Len (ft)	
# Barrels	1	Culv Vel US (ft/s)	5.44
Q Barrel (cfs)	60.00	Culv Vel DS (ft/s)	7.47
E.G. US. (ft)	652.57	Culv Inv El Up (ft)	651.10
W.S. US. (ft)	652.31	Culv Inv El Dn (ft)	650.80
E.G. DS (ft)	652.17	Culv Frctn Ls (ft)	0.14
W.S. DS (ft)	651.72	Culv Exit Loss (ft)	0.16
Delta EG (ft)	0.40	Culv Entr Loss (ft)	0.09
Delta WS (ft)	0.59	Q Weir (cfs)	
E.G. IC (ft)	652.49	Weir Sta Lft (ft)	

```

                                westTribClow.rep
E.G. OC (ft)                    652.57   Weir Sta Rgt (ft)
Culvert Control                 Outlet   Weir Submerg
Culv WS Inlet (ft)             652.02   Weir Max Depth (ft)
Culv WS Outlet (ft)           651.47   Weir Avg Depth (ft)
Culv Nml Depth (ft)           0.58    Weir Flow Area (sq ft)
Culv Crt Depth (ft)           0.92    Min El Weir Flow (ft)    658.61

```

Warning: Since the culvert has supercritical flow, the program should be run in mixed flow in order to check if the cross section downstream of the culvert has supercritical flow.

Note: The flow in the culvert is entirely supercritical.

CULVERT OUTPUT Profile #PF 7 Culv Group: Culvert #1

```

Q Culv Group (cfs)             70.00   Culv Full Len (ft)
# Barrels                      1       Culv Vel US (ft/s)       5.73
Q Barrel (cfs)                 70.00   Culv Vel DS (ft/s)       7.79
E.G. US. (ft)                  652.73   Culv Inv El Up (ft)     651.10
W.S. US. (ft)                  652.44   Culv Inv El Dn (ft)     650.80
E.G. DS (ft)                   652.32   Culv Frctn Ls (ft)       0.14
W.S. DS (ft)                   651.82   Culv Exit Loss (ft)       0.17
Delta EG (ft)                   0.41   Culv Entr Loss (ft)       0.10
Delta WS (ft)                   0.62   Q Weir (cfs)
E.G. IC (ft)                   652.65   Weir Sta Lft (ft)
E.G. OC (ft)                   652.73   Weir Sta Rgt (ft)
Culvert Control                 Outlet   Weir Submerg
Culv WS Inlet (ft)             652.12   Weir Max Depth (ft)
Culv WS Outlet (ft)           651.55   Weir Avg Depth (ft)
Culv Nml Depth (ft)           0.63   Weir Flow Area (sq ft)
Culv Crt Depth (ft)           1.02   Min El Weir Flow (ft)    658.61

```

Warning: Since the culvert has supercritical flow, the program should be run in mixed flow in order to check if the cross section downstream of the culvert has supercritical flow.

Note: The flow in the culvert is entirely supercritical.

CULVERT OUTPUT Profile #PF 8 Culv Group: Culvert #1

```

Q Culv Group (cfs)             80.00   Culv Full Len (ft)
# Barrels                      1       Culv Vel US (ft/s)       5.99
Q Barrel (cfs)                 80.00   Culv Vel DS (ft/s)       8.08
E.G. US. (ft)                  652.88   Culv Inv El Up (ft)     651.10
W.S. US. (ft)                  652.56   Culv Inv El Dn (ft)     650.80
E.G. DS (ft)                   652.46   Culv Frctn Ls (ft)       0.13
W.S. DS (ft)                   651.92   Culv Exit Loss (ft)       0.18
Delta EG (ft)                   0.42   Culv Entr Loss (ft)       0.11
Delta WS (ft)                   0.64   Q Weir (cfs)
E.G. IC (ft)                   652.80   Weir Sta Lft (ft)
E.G. OC (ft)                   652.88   Weir Sta Rgt (ft)
Culvert Control                 Outlet   Weir Submerg
Culv WS Inlet (ft)             652.21   Weir Max Depth (ft)
Culv WS Outlet (ft)           651.63   Weir Avg Depth (ft)
Culv Nml Depth (ft)           0.69   Weir Flow Area (sq ft)
Culv Crt Depth (ft)           1.11   Min El Weir Flow (ft)    658.61

```

Warning: Since the culvert has supercritical flow, the program should be run in mixed flow in order to check if the cross section downstream of the culvert has supercritical flow.

Note: The flow in the culvert is entirely supercritical.

CULVERT OUTPUT Profile #PF 9 Culv Group: Culvert #1

Q Culv Group (cfs)	90.00	Culv Full Len (ft)	
# Barrels	1	Culv Vel US (ft/s)	6.23
Q Barrel (cfs)	90.00	Culv Vel DS (ft/s)	8.34
E.G. US. (ft)	653.03	Culv Inv El Up (ft)	651.10
W.S. US. (ft)	652.68	Culv Inv El Dn (ft)	650.80
E.G. DS (ft)	652.60	Culv Frctn Ls (ft)	0.13
W.S. DS (ft)	652.00	Culv Exit Loss (ft)	0.18
Delta EG (ft)	0.43	Culv Entr Loss (ft)	0.12
Delta WS (ft)	0.68	Q Weir (cfs)	
E.G. IC (ft)	652.95	Weir Sta Lft (ft)	
E.G. OC (ft)	653.03	Weir Sta Rgt (ft)	
Culvert Control	Outlet	Weir Submerg	
Culv WS Inlet (ft)	652.30	Weir Max Depth (ft)	
Culv WS Outlet (ft)	651.70	Weir Avg Depth (ft)	
Culv Nml Depth (ft)	0.74	Weir Flow Area (sq ft)	
Culv Crt Depth (ft)	1.20	Min El Weir Flow (ft)	658.61

Warning: Since the culvert has supercritical flow, the program should be run in mixed flow in order to check if the cross section downstream of the culvert has supercritical flow.

Note: The flow in the culvert is entirely supercritical.

CULVERT OUTPUT Profile #PF 10 Culv Group: Culvert #1

Q Culv Group (cfs)	100.00	Culv Full Len (ft)	
# Barrels	1	Culv Vel US (ft/s)	6.45
Q Barrel (cfs)	100.00	Culv Vel DS (ft/s)	8.58
E.G. US. (ft)	653.17	Culv Inv El Up (ft)	651.10
W.S. US. (ft)	652.80	Culv Inv El Dn (ft)	650.80
E.G. DS (ft)	652.73	Culv Frctn Ls (ft)	0.12
W.S. DS (ft)	652.09	Culv Exit Loss (ft)	0.19
Delta EG (ft)	0.44	Culv Entr Loss (ft)	0.13
Delta WS (ft)	0.71	Q Weir (cfs)	
E.G. IC (ft)	653.09	Weir Sta Lft (ft)	
E.G. OC (ft)	653.17	Weir Sta Rgt (ft)	
Culvert Control	Outlet	Weir Submerg	
Culv WS Inlet (ft)	652.39	Weir Max Depth (ft)	
Culv WS Outlet (ft)	651.77	Weir Avg Depth (ft)	
Culv Nml Depth (ft)	0.79	Weir Flow Area (sq ft)	
Culv Crt Depth (ft)	1.29	Min El Weir Flow (ft)	658.61

Warning: Since the culvert has supercritical flow, the program should be run in mixed flow in order to check if the cross section downstream of the culvert has supercritical flow.

Note: The flow in the culvert is entirely supercritical.

CULVERT OUTPUT Profile #PF 11 Culv Group: Culvert #1

Q Culv Group (cfs)	125.00	Culv Full Len (ft)	
# Barrels	1	Culv Vel US (ft/s)	6.95
Q Barrel (cfs)	125.00	Culv Vel DS (ft/s)	9.11
E.G. US. (ft)	653.50	Culv Inv El Up (ft)	651.10
W.S. US. (ft)	653.07	Culv Inv El Dn (ft)	650.80
E.G. DS (ft)	653.04	Culv Frctn Ls (ft)	0.12
W.S. DS (ft)	652.30	Culv Exit Loss (ft)	0.20
Delta EG (ft)	0.46	Culv Entr Loss (ft)	0.15
Delta WS (ft)	0.78	Q Weir (cfs)	
E.G. IC (ft)	653.42	Weir Sta Lft (ft)	
E.G. OC (ft)	653.50	Weir Sta Rgt (ft)	

WestTribFlow.rep

Culvert Control	Outlet	Weir Submerg	
Culv WS Inlet (ft)	652.60	Weir Max Depth (ft)	
Culv WS Outlet (ft)	651.94	Weir Avg Depth (ft)	
Culv Nml Depth (ft)	0.91	Weir Flow Area (sq ft)	
Culv Crt Depth (ft)	1.50	Min El Weir Flow (ft)	658.61

Warning: Since the culvert has supercritical flow, the program should be run in mixed flow in order to check if the cross section downstream of the culvert has supercritical flow.

Note: The flow in the culvert is entirely supercritical.

CULVERT OUTPUT Profile #PF 12 Culv Group: Culvert #1

Q Culv Group (cfs)	150.00	Culv Full Len (ft)	
# Barrels	1	Culv Vel US (ft/s)	7.38
Q Barrel (cfs)	150.00	Culv Vel DS (ft/s)	9.56
E.G. US. (ft)	653.81	Culv Inv El Up (ft)	651.10
W.S. US. (ft)	653.33	Culv Inv El Dn (ft)	650.80
E.G. DS (ft)	653.32	Culv Frctn Ls (ft)	0.11
W.S. DS (ft)	652.49	Culv Exit Loss (ft)	0.20
Delta EG (ft)	0.49	Culv Entr Loss (ft)	0.17
Delta WS (ft)	0.84	Q Weir (cfs)	
E.G. IC (ft)	653.73	Weir Sta Lft (ft)	
E.G. OC (ft)	653.81	Weir Sta Rgt (ft)	
Culvert Control	Outlet	Weir Submerg	
Culv WS Inlet (ft)	652.79	Weir Max Depth (ft)	
Culv WS Outlet (ft)	652.11	Weir Avg Depth (ft)	
Culv Nml Depth (ft)	1.03	Weir Flow Area (sq ft)	
Culv Crt Depth (ft)	1.69	Min El Weir Flow (ft)	658.61

Warning: Since the culvert has supercritical flow, the program should be run in mixed flow in order to check if the cross section downstream of the culvert has supercritical flow.

Note: The flow in the culvert is entirely supercritical.

CULVERT OUTPUT Profile #PF 13 Culv Group: Culvert #1

Q Culv Group (cfs)	175.00	Culv Full Len (ft)	
# Barrels	1	Culv Vel US (ft/s)	7.77
Q Barrel (cfs)	175.00	Culv Vel DS (ft/s)	9.97
E.G. US. (ft)	654.10	Culv Inv El Up (ft)	651.10
W.S. US. (ft)	653.57	Culv Inv El Dn (ft)	650.80
E.G. DS (ft)	653.59	Culv Frctn Ls (ft)	0.11
W.S. DS (ft)	652.67	Culv Exit Loss (ft)	0.21
Delta EG (ft)	0.51	Culv Entr Loss (ft)	0.19
Delta WS (ft)	0.90	Q Weir (cfs)	
E.G. IC (ft)	654.03	Weir Sta Lft (ft)	
E.G. OC (ft)	654.10	Weir Sta Rgt (ft)	
Culvert Control	Outlet	Weir Submerg	
Culv WS Inlet (ft)	652.98	Weir Max Depth (ft)	
Culv WS Outlet (ft)	652.26	Weir Avg Depth (ft)	
Culv Nml Depth (ft)	1.13	Weir Flow Area (sq ft)	
Culv Crt Depth (ft)	1.88	Min El Weir Flow (ft)	658.61

Warning: Since the culvert has supercritical flow, the program should be run in mixed flow in order to check if the cross section downstream of the culvert has supercritical flow.

Note: The flow in the culvert is entirely supercritical.

CULVERT OUTPUT Profile #PF 14 Culv Group: Culvert #1

westTribFlow.rep

Q Culv Group (cfs)	200.00	Culv Full Len (ft)	
# Barrels	1	Culv Vel US (ft/s)	8.13
Q Barrel (cfs)	200.00	Culv Vel DS (ft/s)	10.33
E.G. US. (ft)	654.38	Culv Inv El Up (ft)	651.10
W.S. US. (ft)	653.81	Culv Inv El Dn (ft)	650.80
E.G. DS (ft)	653.85	Culv Frctn Ls (ft)	0.11
W.S. DS (ft)	652.84	Culv Exit Loss (ft)	0.22
Delta EG (ft)	0.53	Culv Entr Loss (ft)	0.21
Delta WS (ft)	0.97	Q Weir (cfs)	
E.G. IC (ft)	654.31	Weir Sta Lft (ft)	
E.G. OC (ft)	654.38	Weir Sta Rgt (ft)	
Culvert Control	Outlet	Weir Submerg	
Culv WS Inlet (ft)	653.15	Weir Max Depth (ft)	
Culv WS Outlet (ft)	652.41	Weir Avg Depth (ft)	
Culv Nml Depth (ft)	1.23	Weir Flow Area (sq ft)	
Culv Crt Depth (ft)	2.05	Min El Weir Flow (ft)	658.61

Warning: Since the culvert has supercritical flow, the program should be run in mixed flow in order to check if the cross section downstream of the culvert has supercritical flow.

Note: The flow in the culvert is entirely supercritical.

CULVERT OUTPUT Profile #PF 15 Culv Group: Culvert #1

Q Culv Group (cfs)	225.00	Culv Full Len (ft)	
# Barrels	1	Culv Vel US (ft/s)	8.45
Q Barrel (cfs)	225.00	Culv Vel DS (ft/s)	10.66
E.G. US. (ft)	654.65	Culv Inv El Up (ft)	651.10
W.S. US. (ft)	654.03	Culv Inv El Dn (ft)	650.80
E.G. DS (ft)	654.10	Culv Frctn Ls (ft)	0.10
W.S. DS (ft)	653.01	Culv Exit Loss (ft)	0.22
Delta EG (ft)	0.55	Culv Entr Loss (ft)	0.22
Delta WS (ft)	1.02	Q Weir (cfs)	
E.G. IC (ft)	654.59	Weir Sta Lft (ft)	
E.G. OC (ft)	654.65	Weir Sta Rgt (ft)	
Culvert Control	Outlet	Weir Submerg	
Culv WS Inlet (ft)	653.32	Weir Max Depth (ft)	
Culv WS Outlet (ft)	652.56	Weir Avg Depth (ft)	
Culv Nml Depth (ft)	1.33	Weir Flow Area (sq ft)	
Culv Crt Depth (ft)	2.22	Min El Weir Flow (ft)	658.61

Warning: Since the culvert has supercritical flow, the program should be run in mixed flow in order to check if the cross section downstream of the culvert has supercritical flow.

Note: The flow in the culvert is entirely supercritical.

CULVERT OUTPUT Profile #PF 16 Culv Group: Culvert #1

Q Culv Group (cfs)	250.00	Culv Full Len (ft)	
# Barrels	1	Culv Vel US (ft/s)	8.75
Q Barrel (cfs)	250.00	Culv Vel DS (ft/s)	10.97
E.G. US. (ft)	654.91	Culv Inv El Up (ft)	651.10
W.S. US. (ft)	654.25	Culv Inv El Dn (ft)	650.80
E.G. DS (ft)	654.34	Culv Frctn Ls (ft)	0.10
W.S. DS (ft)	653.16	Culv Exit Loss (ft)	0.23
Delta EG (ft)	0.57	Culv Entr Loss (ft)	0.24
Delta WS (ft)	1.09	Q Weir (cfs)	
E.G. IC (ft)	654.85	Weir Sta Lft (ft)	
E.G. OC (ft)	654.91	Weir Sta Rgt (ft)	
Culvert Control	Outlet	Weir Submerg	

		westTribClow.rep		
Culv WS Inlet (ft)	653.48	Weir Max Depth (ft)		
Culv WS Outlet (ft)	652.70	Weir Avg Depth (ft)		
Culv Nml Depth (ft)	1.42	Weir Flow Area (sq ft)		
Culv Crt Depth (ft)	2.38	Min El Weir Flow (ft)		658.61

Warning: Since the culvert has supercritical flow, the program should be run in mixed flow in order to check if the cross section

downstream of the culvert has supercritical flow.

Note: The flow in the culvert is entirely supercritical.

CULVERT OUTPUT Profile #PF 17 Culv Group: Culvert #1

Q Culv Group (cfs)	275.00	Culv Full Len (ft)		
# Barrels	1	Culv Vel US (ft/s)		9.04
Q Barrel (cfs)	275.00	Culv Vel DS (ft/s)		11.26
E.G. US. (ft)	655.16	Culv Inv El Up (ft)		651.10
W.S. US. (ft)	654.46	Culv Inv El Dn (ft)		650.80
E.G. DS (ft)	654.57	Culv Frctn Ls (ft)		0.10
W.S. DS (ft)	653.31	Culv Exit Loss (ft)		0.24
Delta EG (ft)	0.59	Culv Entr Loss (ft)		0.25
Delta WS (ft)	1.15	Q Weir (cfs)		
E.G. IC (ft)	655.11	Weir Sta Lft (ft)		
E.G. OC (ft)	655.16	Weir Sta Rgt (ft)		
Culvert Control	Outlet	Weir Submerg		
Culv WS Inlet (ft)	653.64	Weir Max Depth (ft)		
Culv WS Outlet (ft)	652.84	Weir Avg Depth (ft)		
Culv Nml Depth (ft)	1.51	Weir Flow Area (sq ft)		
Culv Crt Depth (ft)	2.54	Min El Weir Flow (ft)		658.61

Warning: Since the culvert has supercritical flow, the program should be run in mixed flow in order to check if the cross section

downstream of the culvert has supercritical flow.

Note: The flow in the culvert is entirely supercritical.

CULVERT OUTPUT Profile #PF 18 Culv Group: Culvert #1

Q Culv Group (cfs)	300.00	Culv Full Len (ft)		
# Barrels	1	Culv Vel US (ft/s)		9.30
Q Barrel (cfs)	300.00	Culv Vel DS (ft/s)		11.52
E.G. US. (ft)	655.40	Culv Inv El Up (ft)		651.10
W.S. US. (ft)	654.66	Culv Inv El Dn (ft)		650.80
E.G. DS (ft)	654.79	Culv Frctn Ls (ft)		0.10
W.S. DS (ft)	653.48	Culv Exit Loss (ft)		0.24
Delta EG (ft)	0.61	Culv Entr Loss (ft)		0.27
Delta WS (ft)	1.18	Q Weir (cfs)		
E.G. IC (ft)	655.36	Weir Sta Lft (ft)		
E.G. OC (ft)	655.40	Weir Sta Rgt (ft)		
Culvert Control	Outlet	Weir Submerg		
Culv WS Inlet (ft)	653.79	Weir Max Depth (ft)		
Culv WS Outlet (ft)	652.97	Weir Avg Depth (ft)		
Culv Nml Depth (ft)	1.60	Weir Flow Area (sq ft)		
Culv Crt Depth (ft)	2.69	Min El Weir Flow (ft)		658.61

Warning: Since the culvert has supercritical flow, the program should be run in mixed flow in order to check if the cross section

downstream of the culvert has supercritical flow.

Note: The flow in the culvert is entirely supercritical.

CULVERT OUTPUT Profile #PF 19 Culv Group: Culvert #1

		westTribFlow.rep	
Q Culv Group (cfs)	325.00	Culv Full Len (ft)	
# Barrels	1	Culv Vel US (ft/s)	9.55
Q Barrel (cfs)	325.00	Culv Vel DS (ft/s)	11.78
E.G. US. (ft)	655.64	Culv Inv El Up (ft)	651.10
W.S. US. (ft)	654.86	Culv Inv El Dn (ft)	650.80
E.G. DS (ft)	655.01	Culv Frctn Ls (ft)	0.10
W.S. DS (ft)	653.62	Culv Exit Loss (ft)	0.25
Delta EG (ft)	0.63	Culv Entr Loss (ft)	0.28
Delta WS (ft)	1.24	Q Weir (cfs)	
E.G. IC (ft)	655.60	Weir Sta Lft (ft)	
E.G. OC (ft)	655.64	Weir Sta Rgt (ft)	
Culvert Control	Outlet	Weir Submerg	
Culv WS Inlet (ft)	653.93	Weir Max Depth (ft)	
Culv WS Outlet (ft)	653.10	Weir Avg Depth (ft)	
Culv Nml Depth (ft)	1.69	Weir Flow Area (sq ft)	
Culv Crt Depth (ft)	2.83	Min El Weir Flow (ft)	658.61

Warning: Since the culvert has supercritical flow, the program should be run in mixed flow in order to check if the cross section

downstream of the culvert has supercritical flow.

Note: The flow in the culvert is entirely supercritical.

CULVERT OUTPUT Profile #PF 20 Culv Group: Culvert #1

Q Culv Group (cfs)	350.00	Culv Full Len (ft)	
# Barrels	1	Culv Vel US (ft/s)	9.79
Q Barrel (cfs)	350.00	Culv Vel DS (ft/s)	12.02
E.G. US. (ft)	655.87	Culv Inv El Up (ft)	651.10
W.S. US. (ft)	655.05	Culv Inv El Dn (ft)	650.80
E.G. DS (ft)	655.22	Culv Frctn Ls (ft)	0.10
W.S. DS (ft)	653.76	Culv Exit Loss (ft)	0.25
Delta EG (ft)	0.65	Culv Entr Loss (ft)	0.30
Delta WS (ft)	1.30	Q Weir (cfs)	
E.G. IC (ft)	655.84	Weir Sta Lft (ft)	
E.G. OC (ft)	655.87	Weir Sta Rgt (ft)	
Culvert Control	Outlet	Weir Submerg	
Culv WS Inlet (ft)	654.08	Weir Max Depth (ft)	
Culv WS Outlet (ft)	653.23	Weir Avg Depth (ft)	
Culv Nml Depth (ft)	1.78	Weir Flow Area (sq ft)	
Culv Crt Depth (ft)	2.98	Min El Weir Flow (ft)	658.61

Warning: Since the culvert has supercritical flow, the program should be run in mixed flow in order to check if the cross section

downstream of the culvert has supercritical flow.

Note: The flow in the culvert is entirely supercritical.

CULVERT OUTPUT Profile #PF 21 Culv Group: Culvert #1

Q Culv Group (cfs)	375.00	Culv Full Len (ft)	
# Barrels	1	Culv Vel US (ft/s)	10.02
Q Barrel (cfs)	375.00	Culv Vel DS (ft/s)	12.24
E.G. US. (ft)	656.09	Culv Inv El Up (ft)	651.10
W.S. US. (ft)	655.24	Culv Inv El Dn (ft)	650.80
E.G. DS (ft)	655.42	Culv Frctn Ls (ft)	0.10
W.S. DS (ft)	653.90	Culv Exit Loss (ft)	0.26
Delta EG (ft)	0.67	Culv Entr Loss (ft)	0.31
Delta WS (ft)	1.35	Q Weir (cfs)	
E.G. IC (ft)	656.07	Weir Sta Lft (ft)	
E.G. OC (ft)	656.09	Weir Sta Rgt (ft)	
Culvert Control	Outlet	Weir Submerg	
Culv WS Inlet (ft)	654.22	Weir Max Depth (ft)	

		westTribClow.rep	
Culv WS Outlet (ft)	653.35	Weir Avg Depth (ft)	
Culv Nml Depth (ft)	1.86	Weir Flow Area (sq ft)	
Culv Crt Depth (ft)	3.12	Min El Weir Flow (ft)	658.61

Warning: Since the culvert has supercritical flow, the program should be run in mixed flow in order to check if the cross section downstream of the culvert has supercritical flow.

Note: The flow in the culvert is entirely supercritical.

CULVERT OUTPUT Profile #PF 22 Culv Group: Culvert #1

Q Culv Group (cfs)	400.00	Culv Full Len (ft)	
# Barrels	1	Culv Vel US (ft/s)	10.24
Q Barrel (cfs)	400.00	Culv Vel DS (ft/s)	12.46
E.G. US. (ft)	656.31	Culv Inv El Up (ft)	651.10
W.S. US. (ft)	655.43	Culv Inv El Dn (ft)	650.80
E.G. DS (ft)	655.62	Culv Frctn Ls (ft)	0.10
W.S. DS (ft)	654.04	Culv Exit Loss (ft)	0.26
Delta EG (ft)	0.69	Culv Entr Loss (ft)	0.33
Delta WS (ft)	1.39	Q Weir (cfs)	
E.G. IC (ft)	656.30	Weir Sta Lft (ft)	
E.G. OC (ft)	656.31	Weir Sta Rgt (ft)	
Culvert Control	Outlet	Weir Submerg	
Culv WS Inlet (ft)	654.36	Weir Max Depth (ft)	
Culv WS Outlet (ft)	653.47	Weir Avg Depth (ft)	
Culv Nml Depth (ft)	1.94	Weir Flow Area (sq ft)	
Culv Crt Depth (ft)	3.26	Min El Weir Flow (ft)	658.61

Warning: Since the culvert has supercritical flow, the program should be run in mixed flow in order to check if the cross section downstream of the culvert has supercritical flow.

Note: The flow in the culvert is entirely supercritical.

CULVERT OUTPUT Profile #PF 23 Culv Group: Culvert #1

Q Culv Group (cfs)	425.00	Culv Full Len (ft)	
# Barrels	1	Culv Vel US (ft/s)	10.45
Q Barrel (cfs)	425.00	Culv Vel DS (ft/s)	12.67
E.G. US. (ft)	656.52	Culv Inv El Up (ft)	651.10
W.S. US. (ft)	655.61	Culv Inv El Dn (ft)	650.80
E.G. DS (ft)	655.82	Culv Frctn Ls (ft)	0.10
W.S. DS (ft)	654.16	Culv Exit Loss (ft)	0.27
Delta EG (ft)	0.70	Culv Entr Loss (ft)	0.34
Delta WS (ft)	1.45	Q Weir (cfs)	
E.G. IC (ft)	656.52	Weir Sta Lft (ft)	
E.G. OC (ft)	656.52	Weir Sta Rgt (ft)	
Culvert Control	Outlet	Weir Submerg	
Culv WS Inlet (ft)	654.49	Weir Max Depth (ft)	
Culv WS Outlet (ft)	653.60	Weir Avg Depth (ft)	
Culv Nml Depth (ft)	2.02	Weir Flow Area (sq ft)	
Culv Crt Depth (ft)	3.39	Min El Weir Flow (ft)	658.61

Warning: Since the culvert has supercritical flow, the program should be run in mixed flow in order to check if the cross section downstream of the culvert has supercritical flow.

Note: The flow in the culvert is entirely supercritical.

CULVERT OUTPUT Profile #PF 24 Culv Group: Culvert #1

Q Culv Group (cfs)	450.00	Culv Full Len (ft)	
--------------------	--------	--------------------	--

westTribCflow.rep			
# Barrels	1	Culv Vel US (ft/s)	10.65
Q Barrel (cfs)	450.00	Culv Vel DS (ft/s)	12.87
E.G. US. (ft)	656.74	Culv Inv El Up (ft)	651.10
W.S. US. (ft)	655.80	Culv Inv El Dn (ft)	650.80
E.G. DS (ft)	656.01	Culv Frctn Ls (ft)	0.10
W.S. DS (ft)	654.30	Culv Exit Loss (ft)	0.27
Delta EG (ft)	0.73	Culv Entr Loss (ft)	0.36
Delta WS (ft)	1.50	Q Weir (cfs)	
E.G. IC (ft)	656.74	Weir Sta Lft (ft)	
E.G. OC (ft)	656.73	Weir Sta Rgt (ft)	
Culvert Control	Inlet	Weir Submerg	
Culv WS Inlet (ft)	654.62	Weir Max Depth (ft)	
Culv WS Outlet (ft)	653.71	Weir Avg Depth (ft)	
Culv Nml Depth (ft)	2.10	Weir Flow Area (sq ft)	
Culv Crt Depth (ft)	3.52	Min El Weir Flow (ft)	658.61

Warning: Since the culvert has supercritical flow, the program should be run in mixed flow in order to check if the cross section downstream of the culvert has supercritical flow.

Note: The flow in the culvert is entirely supercritical.

CULVERT OUTPUT Profile #PF 25 Culv Group: Culvert #1

Q Culv Group (cfs)	475.00	Culv Full Len (ft)	
# Barrels	1	Culv Vel US (ft/s)	10.84
Q Barrel (cfs)	475.00	Culv Vel DS (ft/s)	13.06
E.G. US. (ft)	656.96	Culv Inv El Up (ft)	651.10
W.S. US. (ft)	655.99	Culv Inv El Dn (ft)	650.80
E.G. DS (ft)	656.20	Culv Frctn Ls (ft)	0.10
W.S. DS (ft)	654.43	Culv Exit Loss (ft)	0.28
Delta EG (ft)	0.75	Culv Entr Loss (ft)	0.38
Delta WS (ft)	1.56	Q Weir (cfs)	
E.G. IC (ft)	656.96	Weir Sta Lft (ft)	
E.G. OC (ft)	656.94	Weir Sta Rgt (ft)	
Culvert Control	Inlet	Weir Submerg	
Culv WS Inlet (ft)	654.75	Weir Max Depth (ft)	
Culv WS Outlet (ft)	653.83	Weir Avg Depth (ft)	
Culv Nml Depth (ft)	2.17	Weir Flow Area (sq ft)	
Culv Crt Depth (ft)	3.65	Min El Weir Flow (ft)	658.61

Warning: Since the culvert has supercritical flow, the program should be run in mixed flow in order to check if the cross section downstream of the culvert has supercritical flow.

Note: The flow in the culvert is entirely supercritical.

CULVERT OUTPUT Profile #PF 26 Culv Group: Culvert #1

Q Culv Group (cfs)	500.00	Culv Full Len (ft)	
# Barrels	1	Culv Vel US (ft/s)	11.03
Q Barrel (cfs)	500.00	Culv Vel DS (ft/s)	13.25
E.G. US. (ft)	657.17	Culv Inv El Up (ft)	651.10
W.S. US. (ft)	656.18	Culv Inv El Dn (ft)	650.80
E.G. DS (ft)	656.39	Culv Frctn Ls (ft)	0.10
W.S. DS (ft)	654.56	Culv Exit Loss (ft)	0.28
Delta EG (ft)	0.78	Culv Entr Loss (ft)	0.40
Delta WS (ft)	1.62	Q Weir (cfs)	
E.G. IC (ft)	657.17	Weir Sta Lft (ft)	
E.G. OC (ft)	657.14	Weir Sta Rgt (ft)	
Culvert Control	Inlet	Weir Submerg	
Culv WS Inlet (ft)	654.88	Weir Max Depth (ft)	
Culv WS Outlet (ft)	653.94	Weir Avg Depth (ft)	

		westTribClow.rep	
Culv Nml Depth (ft)	2.25	Weir Flow Area (sq ft)	
Culv Crt Depth (ft)	3.78	Min El Weir Flow (ft)	658.61

Warning: Since the culvert has supercritical flow, the program should be run in mixed flow in order to check if the cross section downstream of the culvert has supercritical flow.
 Note: The flow in the culvert is entirely supercritical.

CULVERT OUTPUT Profile #PF 27 Culv Group: Culvert #1

Q Culv Group (cfs)	525.00	Culv Full Len (ft)	
# Barrels	1	Culv Vel US (ft/s)	11.21
Q Barrel (cfs)	525.00	Culv Vel DS (ft/s)	13.43
E.G. US. (ft)	657.38	Culv Inv El Up (ft)	651.10
W.S. US. (ft)	656.37	Culv Inv El Dn (ft)	650.80
E.G. DS (ft)	656.57	Culv Frctn Ls (ft)	0.10
W.S. DS (ft)	654.68	Culv Exit Loss (ft)	0.29
Delta EG (ft)	0.81	Culv Entr Loss (ft)	0.42
Delta WS (ft)	1.69	Q Weir (cfs)	
E.G. IC (ft)	657.38	Weir Sta Lft (ft)	
E.G. OC (ft)	657.34	Weir Sta Rgt (ft)	
Culvert Control	Inlet	Weir Submerg	
Culv WS Inlet (ft)	655.00	Weir Max Depth (ft)	
Culv WS Outlet (ft)	654.06	Weir Avg Depth (ft)	
Culv Nml Depth (ft)	2.33	Weir Flow Area (sq ft)	
Culv Crt Depth (ft)	3.90	Min El Weir Flow (ft)	658.61

Warning: Since the culvert has supercritical flow, the program should be run in mixed flow in order to check if the cross section downstream of the culvert has supercritical flow.
 Note: The flow in the culvert is entirely supercritical.

CULVERT OUTPUT Profile #PF 28 Culv Group: Culvert #1

Q Culv Group (cfs)	550.00	Culv Full Len (ft)	
# Barrels	1	Culv Vel US (ft/s)	11.39
Q Barrel (cfs)	550.00	Culv Vel DS (ft/s)	13.60
E.G. US. (ft)	657.58	Culv Inv El Up (ft)	651.10
W.S. US. (ft)	656.55	Culv Inv El Dn (ft)	650.80
E.G. DS (ft)	656.75	Culv Frctn Ls (ft)	0.10
W.S. DS (ft)	654.79	Culv Exit Loss (ft)	0.30
Delta EG (ft)	0.84	Culv Entr Loss (ft)	0.45
Delta WS (ft)	1.76	Q Weir (cfs)	
E.G. IC (ft)	657.58	Weir Sta Lft (ft)	
E.G. OC (ft)	657.54	Weir Sta Rgt (ft)	
Culvert Control	Inlet	Weir Submerg	
Culv WS Inlet (ft)	655.13	Weir Max Depth (ft)	
Culv WS Outlet (ft)	654.17	Weir Avg Depth (ft)	
Culv Nml Depth (ft)	2.40	Weir Flow Area (sq ft)	
Culv Crt Depth (ft)	4.03	Min El Weir Flow (ft)	658.61

Warning: Since the culvert has supercritical flow, the program should be run in mixed flow in order to check if the cross section downstream of the culvert has supercritical flow.
 Note: The flow in the culvert is entirely supercritical.

CULVERT OUTPUT Profile #PF 29 Culv Group: Culvert #1

Q Culv Group (cfs)	575.00	Culv Full Len (ft)	
# Barrels	1	Culv Vel US (ft/s)	11.56

```

westTribClow.rep
Q Barrel (cfs)          575.00    Culv Vel DS (ft/s)      13.77
E.G. US. (ft)          657.79    Culv Inv El Up (ft)    651.10
W.S. US. (ft)          656.73    Culv Inv El Dn (ft)    650.80
E.G. DS (ft)           656.92    Culv Frctn Ls (ft)     0.10
W.S. DS (ft)           654.91    Culv Exit Loss (ft)    0.30
Delta EG (ft)           0.86     Culv Entr Loss (ft)    0.47
Delta WS (ft)           1.82     Q Weir (cfs)
E.G. IC (ft)           657.79    Weir Sta Lft (ft)
E.G. OC (ft)           657.73    Weir Sta Rgt (ft)
Culvert Control        Inlet     Weir Submerg
Culv WS Inlet (ft)     655.25    Weir Max Depth (ft)
Culv WS Outlet (ft)    654.28    Weir Avg Depth (ft)
Culv Nml Depth (ft)    2.47     Weir Flow Area (sq ft)
Culv Crt Depth (ft)    4.15     Min El Weir Flow (ft)  658.61

```

Warning: Since the culvert has supercritical flow, the program should be run in mixed flow in order to check if the cross section downstream of the culvert has supercritical flow.
Note: The flow in the culvert is entirely supercritical.

CULVERT OUTPUT Profile #PF 30 Culv Group: culvert #1

```

Q Culv Group (cfs)      600.00    Culv Full Len (ft)
# Barrels                1         Culv Vel US (ft/s)      11.72
Q Barrel (cfs)          600.00    Culv Vel DS (ft/s)      13.93
E.G. US. (ft)           657.99    Culv Inv El Up (ft)    651.10
W.S. US. (ft)           656.91    Culv Inv El Dn (ft)    650.80
E.G. DS (ft)            657.10    Culv Frctn Ls (ft)     0.10
W.S. DS (ft)            655.02    Culv Exit Loss (ft)    0.31
Delta EG (ft)            0.89     Culv Entr Loss (ft)    0.49
Delta WS (ft)            1.89     Q Weir (cfs)
E.G. IC (ft)            657.99    Weir Sta Lft (ft)
E.G. OC (ft)            657.93    Weir Sta Rgt (ft)
Culvert Control        Inlet     Weir Submerg
Culv WS Inlet (ft)     655.37    Weir Max Depth (ft)
Culv WS Outlet (ft)    654.39    Weir Avg Depth (ft)
Culv Nml Depth (ft)    2.54     Weir Flow Area (sq ft)
Culv Crt Depth (ft)    4.27     Min El Weir Flow (ft)  658.61

```

Warning: Since the culvert has supercritical flow, the program should be run in mixed flow in order to check if the cross section downstream of the culvert has supercritical flow.
Note: The flow in the culvert is entirely supercritical.

CROSS SECTION

RIVER: WestTribClow
REACH: WestTribClow RS: 1787

INPUT

Description: Sta: 17+87

```

Station Elevation Data num= 11
Sta Elev Sta Elev Sta Elev Sta Elev Sta Elev
-81 658.9 -58 658.6 -24 658 -17 657 -6.5 658
-6 650.8 0 650.8 6 650.8 6.5 658 22.5 658
46.5 659

```

```

Manning's n Values num= 3
Sta n Val Sta n Val Sta n Val
-81 .08 -6.5 .03 6.5 .08

```

WestTribClow.rep

Bank Sta: Left	Right	Lengths: Left	Channel	Right	Coeff	Contr.	Expan.
-6.5	6.5	10	10	10	.1	.3	
Ineffective Flow	num=	2					
Sta L	Sta R	Elev	Permanent				
-81	-6.5	658.1	F				
6.5	46.5	658.6	F				

CROSS SECTION OUTPUT Profile #PF 1

E.G. Elev (ft)	651.22	Element	Left OB	Channel
Right OB				
Vel Head (ft)	0.14	Wt. n-val.		0.030
W.S. Elev (ft)	651.08	Reach Len. (ft)	10.00	10.00
10.00				
Crit w.s. (ft)	651.08	Flow Area (sq ft)		3.35
E.G. Slope (ft/ft)	0.021145	Area (sq ft)		3.35
Q Total (cfs)	10.00	Flow (cfs)		10.00
Top width (ft)	12.04	Top width (ft)		12.04
Vel Total (ft/s)	2.98	Avg. Vel. (ft/s)		2.98
Max Chl Dpth (ft)	0.28	Hydr. Depth (ft)		0.28
Conv. Total (cfs)	68.8	Conv. (cfs)		68.8
Length wtd. (ft)	10.00	wetted Per. (ft)		12.56
Min Ch El (ft)	650.80	Shear (lb/sq ft)		0.35
Alpha	1.00	Stream Power (lb/ft s)	46.50	0.00
0.00				
Frctn Loss (ft)	0.13	Cum Volume (acre-ft)		0.10
C & E Loss (ft)	0.02	Cum SA (acres)		0.19

Warning: The energy equation could not be balanced within the specified number of iterations. The program used critical depth for the water surface and continued on with the calculations.

Warning: The conveyance ratio (upstream conveyance divided by downstream conveyance) is less than 0.7 or greater than 1.4. This may indicate the need for additional cross sections.

Warning: During the standard step iterations, when the assumed water surface was set equal to critical depth, the calculated water surface came back below critical depth. This indicates that there is not a valid subcritical answer. The program defaulted to critical depth.

Note: Multiple critical depths were found at this location. The critical depth with the lowest, valid, water surface was used.

CROSS SECTION OUTPUT Profile #PF 2

E.G. Elev (ft)	651.46	Element	Left OB	Channel
Right OB				

westTribClow.rep				
Vel Head (ft)	0.22	wt. n-Val.		0.030
W.S. Elev (ft)	651.24	Reach Len. (ft)	10.00	10.00
10.00 Crit W.S. (ft)	651.24	Flow Area (sq ft)		5.31
E.G. Slope (ft/ft)	0.018851	Area (sq ft)		5.31
Q Total (cfs)	20.00	Flow (cfs)		20.00
Top Width (ft)	12.06	Top Width (ft)		12.06
Vel Total (ft/s)	3.77	Avg. Vel. (ft/s)		3.77
Max Chl Dpth (ft)	0.44	Hydr. Depth (ft)		0.44
Conv. Total (cfs)	145.7	Conv. (cfs)		145.7
Length Wtd. (ft)	10.00	wetted Per. (ft)		12.88
Min Ch El (ft)	650.80	Shear (lb/sq ft)		0.49
Alpha 0.00	1.00	Stream Power (lb/ft s)	46.50	0.00
Frctn Loss (ft)	0.12	Cum Volume (acre-ft)		0.17
C & E Loss (ft)	0.03	Cum SA (acres)		0.23

Warning: The energy equation could not be balanced within the specified number of iterations. The program used critical depth for the water surface and continued on with the calculations.

Warning: The conveyance ratio (upstream conveyance divided by downstream conveyance) is less than 0.7 or greater than 1.4. This may indicate the need for additional cross sections.

Warning: During the standard step iterations, when the assumed water surface was set equal to critical depth, the calculated water surface came back below critical depth. This indicates that there is not a valid subcritical answer. The program defaulted to critical depth.

Note: Multiple critical depths were found at this location. The critical depth with the lowest, valid, water surface was used.

CROSS SECTION OUTPUT Profile #PF 3

Right OB				
E.G. Elev (ft)	651.67	Element	Left OB	Channel
Vel Head (ft)	0.29	wt. n-Val.		0.030
W.S. Elev (ft)	651.37	Reach Len. (ft)	10.00	10.00
10.00 Crit W.S. (ft)	651.37	Flow Area (sq ft)		6.92
E.G. Slope (ft/ft)	0.018041	Area (sq ft)		6.92
Q Total (cfs)	30.00	Flow (cfs)		30.00
Top Width (ft)	12.08	Top Width (ft)		12.08
Vel Total (ft/s)	4.34	Avg. Vel. (ft/s)		4.34

westTribClow.rep

Max Chl Dpth (ft)	0.57	Hydr. Depth (ft)		0.57
Conv. Total (cfs)	223.4	Conv. (cfs)		223.4
Length wtd. (ft)	10.00	wetted Per. (ft)		13.15
Min Ch El (ft)	650.80	Shear (lb/sq ft)		0.59
Alpha 0.00	1.00	Stream Power (lb/ft s)	46.50	0.00
Frctn Loss (ft)	0.13	Cum Volume (acre-ft)		0.23
C & E Loss (ft)	0.03	Cum SA (acres)		0.27

Warning: The energy equation could not be balanced within the specified number of iterations. The program used critical depth for the water surface and continued on with the calculations.
 Warning: During the standard step iterations, when the assumed water surface was set equal to critical depth, the calculated water surface came back below critical depth. This indicates that there is not a valid subcritical answer. The program defaulted to critical depth.
 Note: Multiple critical depths were found at this location. The critical depth with the lowest, valid, water surface was used.

CROSS SECTION OUTPUT Profile #PF 4

E.G. Elev (ft)	651.85	Element	Left OB	Channel
Right OB Vel Head (ft)	0.35	wt. n-Val.		0.030
w.s. Elev (ft)	651.50	Reach Len. (ft)	10.00	10.00
10.00 Crit w.s. (ft)	651.50	Flow Area (sq ft)		8.44
E.G. Slope (ft/ft)	0.016988	Area (sq ft)		8.44
Q Total (cfs)	40.00	Flow (cfs)		40.00
Top width (ft)	12.10	Top width (ft)		12.10
Vel Total (ft/s)	4.74	Avg. Vel. (ft/s)		4.74
Max Chl Dpth (ft)	0.70	Hydr. Depth (ft)		0.70
Conv. Total (cfs)	306.9	Conv. (cfs)		306.9
Length wtd. (ft)	10.00	wetted Per. (ft)		13.40
Min Ch El (ft)	650.80	Shear (lb/sq ft)		0.67
Alpha 0.00	1.00	Stream Power (lb/ft s)	46.50	0.00
Frctn Loss (ft)	0.13	Cum Volume (acre-ft)		0.28
C & E Loss (ft)	0.03	Cum SA (acres)		0.28

WestTribClow.rep

Warning: The energy equation could not be balanced within the specified number of iterations. The program used critical depth for the water surface and continued on with the calculations.
 Warning: During the standard step iterations, when the assumed water surface was set equal to critical depth, the calculated water surface came back below critical depth. This indicates that there is not a valid subcritical answer. The program defaulted to critical depth.
 Note: Multiple critical depths were found at this location. The critical depth with the lowest, valid, water surface was used.

CROSS SECTION OUTPUT Profile #PF 5

E.G. Elev (ft)	652.02	Element	Left OB	Channel
Right OB Vel Head (ft)	0.41	wt. n-val.		0.030
W.S. Elev (ft)	651.61	Reach Len. (ft)	10.00	10.00
10.00 Crit w.s. (ft)	651.61	Flow Area (sq ft)		9.78
E.G. Slope (ft/ft)	0.016578	Area (sq ft)		9.78
Q Total (cfs)	50.00	Flow (cfs)		50.00
Top width (ft)	12.11	Top width (ft)		12.11
Vel Total (ft/s)	5.11	Avg. vel. (ft/s)		5.11
Max Chl Dpth (ft)	0.81	Hydr. Depth (ft)		0.81
Conv. Total (cfs)	388.3	Conv. (cfs)		388.3
Length wtd. (ft)	10.00	wetted Per. (ft)		13.63
Min Ch El (ft)	650.80	Shear (lb/sq ft)		0.74
Alpha 0.00	1.00	Stream Power (lb/ft s)	46.50	0.00
Frctn Loss (ft)	0.13	Cum volume (acre-ft)		0.33
C & E Loss (ft)	0.04	Cum SA (acres)		0.30

Warning: The energy equation could not be balanced within the specified number of iterations. The program used critical depth for the water surface and continued on with the calculations.
 Warning: During the standard step iterations, when the assumed water surface was set equal to critical depth, the calculated water surface came back below critical depth. This indicates that there is not a valid subcritical answer. The program defaulted to critical depth.
 Note: Multiple critical depths were found at this location. The critical depth with the lowest, valid, water surface was used.

CROSS SECTION OUTPUT Profile #PF 6

westTribClow.rep				
		Element	Left OB	Channel
E.G. Elev (ft)	652.17			
Right OB				
Vel Head (ft)	0.46	wt. n-Val.		0.030
W.S. Elev (ft)	651.72	Reach Len. (ft)	10.00	10.00
10.00				
Crit w.s. (ft)	651.72	Flow Area (sq ft)		11.07
E.G. Slope (ft/ft)	0.016136	Area (sq ft)		11.07
Q Total (cfs)	60.00	Flow (cfs)		60.00
Top width (ft)	12.13	Top width (ft)		12.13
Vel Total (ft/s)	5.42	Avg. Vel. (ft/s)		5.42
Max Chl Dpth (ft)	0.92	Hydr. Depth (ft)		0.91
Conv. Total (cfs)	472.3	Conv. (cfs)		472.3
Length wtd. (ft)	10.00	wetted Per. (ft)		13.84
Min Ch El (ft)	650.80	Shear (lb/sq ft)		0.81
Alpha	1.00	Stream Power (lb/ft s)	46.50	0.00
0.00				
Frctn Loss (ft)	0.13	Cum Volume (acre-ft)		0.38
C & E Loss (ft)	0.04	Cum SA (acres)		0.31

Warning: The energy equation could not be balanced within the specified number of iterations. The program used critical depth for the water surface and continued on with the calculations.

Warning: During the standard step iterations, when the assumed water surface was set equal to critical depth, the calculated water surface came back below critical depth. This indicates that there is not a valid subcritical answer. The program defaulted to critical depth.

Note: Multiple critical depths were found at this location. The critical depth with the lowest, valid, water surface was used.

CROSS SECTION OUTPUT Profile #PF 7

		Element	Left OB	Channel
E.G. Elev (ft)	652.32			
Right OB				
Vel Head (ft)	0.50	wt. n-Val.		0.030
W.S. Elev (ft)	651.82	Reach Len. (ft)	10.00	10.00
10.00				
Crit w.s. (ft)	651.82	Flow Area (sq ft)		12.33
E.G. Slope (ft/ft)	0.015635	Area (sq ft)		12.33
Q Total (cfs)	70.00	Flow (cfs)		70.00
Top width (ft)	12.14	Top width (ft)		12.14
Vel Total (ft/s)	5.68	Avg. Vel. (ft/s)		5.68

		westTribClow.rep		
Max Chl Dpth (ft)	1.02	Hydr. Depth (ft)		1.02
Conv. Total (cfs)	559.8	Conv. (cfs)		559.8
Length Wtd. (ft)	10.00	wetted Per. (ft)		14.05
Min Ch El (ft)	650.80	Shear (lb/sq ft)		0.86
Alpha 0.00	1.00	Stream Power (lb/ft s)	46.50	0.00
Frctn Loss (ft)	0.12	Cum volume (acre-ft)		0.42
C & E Loss (ft)	0.05	Cum SA (acres)		0.32

Warning: The energy equation could not be balanced within the specified number of iterations. The program used critical depth for the water surface and continued on with the calculations.

Warning: During the standard step iterations, when the assumed water surface was set equal to critical depth, the calculated water surface came back below critical depth. This indicates that there is not a valid subcritical answer. The program defaulted to critical depth.

Note: Multiple critical depths were found at this location. The critical depth with the lowest, valid, water surface was used.

CROSS SECTION OUTPUT Profile #PF 8

E.G. Elev (ft)	652.46	Element	Left OB	Channel
Right OB Vel Head (ft)	0.54	wt. n-val.		0.030
W.S. Elev (ft)	651.92	Reach Len. (ft)	10.00	10.00
10.00 Crit w.s. (ft)	651.92	Flow Area (sq ft)		13.53
E.G. slope (ft/ft)	0.015267	Area (sq ft)		13.53
Q Total (cfs)	80.00	Flow (cfs)		80.00
Top width (ft)	12.16	Top width (ft)		12.16
Vel Total (ft/s)	5.91	Avg. vel. (ft/s)		5.91
Max Chl Dpth (ft)	1.12	Hydr. Depth (ft)		1.11
Conv. Total (cfs)	647.5	Conv. (cfs)		647.5
Length Wtd. (ft)	10.00	wetted Per. (ft)		14.25
Min Ch El (ft)	650.80	Shear (lb/sq ft)		0.91
Alpha 0.00	1.00	Stream Power (lb/ft s)	46.50	0.00
Frctn Loss (ft)	0.12	Cum volume (acre-ft)		0.47
C & E Loss (ft)	0.06	Cum SA (acres)		0.33

WestTribFlow.rep

Warning: The energy equation could not be balanced within the specified number of iterations. The program used critical depth for the water surface and continued on with the calculations.
 Warning: During the standard step iterations, when the assumed water surface was set equal to critical depth, the calculated water surface came back below critical depth. This indicates that there is not a valid subcritical answer. The program defaulted to critical depth.
 Note: Multiple critical depths were found at this location. The critical depth with the lowest, valid, water surface was used.

CROSS SECTION OUTPUT Profile #PF 9

E.G. Elev (ft)	652.60	Element	Left OB	Channel
Right OB Vel Head (ft)	0.60	wt. n-Val.		0.030
w.s. Elev (ft)	652.00	Reach Len. (ft)	10.00	10.00
10.00 Crit w.s. (ft)	652.00	Flow Area (sq ft)		14.51
E.G. Slope (ft/ft)	0.015528	Area (sq ft)		14.51
Q Total (cfs)	90.00	Flow (cfs)		90.00
Top width (ft)	12.17	Top width (ft)		12.17
Vel Total (ft/s)	6.20	Avg. Vel. (ft/s)		6.20
Max Chl Dpth (ft)	1.20	Hydr. Depth (ft)		1.19
Conv. Total (cfs)	722.3	Conv. (cfs)		722.3
Length wtd. (ft)	10.00	wetted Per. (ft)		14.41
Min Ch El (ft)	650.80	Shear (lb/sq ft)		0.98
Alpha 0.00	1.00	Stream Power (lb/ft s)	46.50	0.00
Frctn Loss (ft)	0.11	Cum Volume (acre-ft)		0.50
C & E Loss (ft)	0.07	Cum SA (acres)		0.33

Warning: The energy equation could not be balanced within the specified number of iterations. The program used critical depth for the water surface and continued on with the calculations.
 Warning: During the standard step iterations, when the assumed water surface was set equal to critical depth, the calculated water surface came back below critical depth. This indicates that there is not a valid subcritical answer. The program defaulted to critical depth.
 Note: Multiple critical depths were found at this location. The critical depth with the lowest, valid, water surface was used.

CROSS SECTION OUTPUT Profile #PF 10

E.G. Elev (ft)	652.73	Element	Left OB	Channel
----------------	--------	---------	---------	---------

westTribClow.rep

Right OB				
Vel Head (ft)	0.64	Wt. n-val.		0.030
W.S. Elev (ft)	652.09	Reach Len. (ft)	10.00	10.00
10.00				
Crit w.s. (ft)	652.09	Flow Area (sq ft)		15.61
E.G. Slope (ft/ft)	0.015278	Area (sq ft)		15.61
Q Total (cfs)	100.00	Flow (cfs)		100.00
Top width (ft)	12.18	Top width (ft)		12.18
Vel Total (ft/s)	6.41	Avg. Vel. (ft/s)		6.41
Max Chl Dpth (ft)	1.29	Hydr. Depth (ft)		1.28
Conv. Total (cfs)	809.0	Conv. (cfs)		809.0
Length wtd. (ft)	10.00	wetted Per. (ft)		14.59
Min ch El (ft)	650.80	Shear (lb/sq ft)		1.02
Alpha	1.00	Stream Power (lb/ft s)	46.50	0.00
0.00				
Frctn Loss (ft)	0.11	Cum Volume (acre-ft)		0.54
C & E Loss (ft)	0.08	Cum SA (acres)		0.34

Warning: The energy equation could not be balanced within the specified number of iterations. The program used critical depth for the water surface and continued on with the calculations.

Warning: During the standard step iterations, when the assumed water surface was set equal to critical depth, the calculated water surface came back below critical depth. This indicates that there is not a valid subcritical answer. The program defaulted to critical depth.

Note: Multiple critical depths were found at this location. The critical depth with the lowest, valid, water surface was used.

CROSS SECTION OUTPUT Profile #PF 11

E.G. Elev (ft)	653.04	Element	Left OB	Channel
Right OB				
Vel Head (ft)	0.74	Wt. n-val.		0.030
W.S. Elev (ft)	652.30	Reach Len. (ft)	10.00	10.00
10.00				
Crit w.s. (ft)	652.30	Flow Area (sq ft)		18.12
E.G. Slope (ft/ft)	0.015078	Area (sq ft)		18.12
Q Total (cfs)	125.00	Flow (cfs)		125.00
Top width (ft)	12.21	Top width (ft)		12.21
Vel Total (ft/s)	6.90	Avg. Vel. (ft/s)		6.90
Max Chl Dpth (ft)	1.50	Hydr. Depth (ft)		1.48

westTribClow.rep

Conv. Total (cfs)	1018.0	Conv. (cfs)	1018.0
Length wtd. (ft)	10.00	wetted Per. (ft)	15.00
Min Ch El (ft)	650.80	Shear (lb/sq ft)	1.14
Alpha 0.00	1.00	Stream Power (lb/ft s)	46.50
Frctn Loss (ft)	0.10	Cum Volume (acre-ft)	0.63
C & E Loss (ft)	0.11	Cum SA (acres)	0.36

Warning: The energy equation could not be balanced within the specified number of iterations. The program used critical depth for the water surface and continued on with the calculations.

Warning: The conveyance ratio (upstream conveyance divided by downstream conveyance) is less than 0.7 or greater than 1.4. This may indicate the need for additional cross sections.

Warning: During the standard step iterations, when the assumed water surface was set equal to critical depth, the calculated water surface came back below critical depth. This indicates that there is not a valid subcritical answer. The program defaulted to critical depth.

Note: Multiple critical depths were found at this location. The critical depth with the lowest, valid, water surface was used.

CROSS SECTION OUTPUT Profile #PF 12

E.G. Elev (ft)	653.32	Element	Left OB	Channel
Right OB Vel Head (ft)	0.84	wt. n-val.		0.030
w.s. Elev (ft)	652.49	Reach Len. (ft)	10.00	10.00
10.00 Crit w.s. (ft)	652.49	Flow Area (sq ft)		20.45
E.G. Slope (ft/ft)	0.015004	Area (sq ft)		20.45
Q Total (cfs)	150.00	Flow (cfs)		150.00
Top width (ft)	12.23	Top width (ft)		12.23
Vel Total (ft/s)	7.33	Avg. Vel. (ft/s)		7.33
Max Chl Dpth (ft)	1.69	Hydr. Depth (ft)		1.67
Conv. Total (cfs)	1224.6	Conv. (cfs)		1224.6
Length wtd. (ft)	10.00	wetted Per. (ft)		15.38
Min Ch El (ft)	650.80	Shear (lb/sq ft)		1.25
Alpha 0.00	1.00	Stream Power (lb/ft s)	46.50	0.00
Frctn Loss (ft)	0.09	Cum Volume (acre-ft)		0.72
C & E Loss (ft)	0.13	Cum SA (acres)		0.37

Warning: The energy equation could not be balanced within the specified number of iterations. The program used critical depth for the water surface and continued on with the calculations.
 Warning: The conveyance ratio (upstream conveyance divided by downstream conveyance) is less than 0.7 or greater than 1.4.
 This may indicate the need for additional cross sections.
 Warning: During the standard step iterations, when the assumed water surface was set equal to critical depth, the calculated water surface came back below critical depth. This indicates that there is not a valid subcritical answer. The program defaulted to critical depth.
 Note: Multiple critical depths were found at this location. The critical depth with the lowest, valid, water surface was used.

CROSS SECTION OUTPUT Profile #PF 13

E.G. Elev (ft)	653.59	Element	Left OB	Channel
Right OB				
Vel Head (ft)	0.92	wt. n-val.		0.030
W.S. Elev (ft)	652.67	Reach Len. (ft)	10.00	10.00
10.00				
Crit w.s. (ft)	652.67	Flow Area (sq ft)		22.73
E.G. Slope (ft/ft)	0.014833	Area (sq ft)		22.73
Q Total (cfs)	175.00	Flow (cfs)		175.00
Top width (ft)	12.26	Top width (ft)		12.26
Vel Total (ft/s)	7.70	Avg. Vel. (ft/s)		7.70
Max Chl Dpth (ft)	1.87	Hydr. Depth (ft)		1.85
Conv. Total (cfs)	1436.9	Conv. (cfs)		1436.9
Length Wtd. (ft)	10.00	wetted Per. (ft)		15.76
Min Ch El (ft)	650.80	Shear (lb/sq ft)		1.34
Alpha	1.00	Stream Power (lb/ft s)	46.50	0.00
0.00				
Frctn Loss (ft)	0.08	Cum Volume (acre-ft)		0.80
C & E Loss (ft)	0.15	Cum SA (acres)		0.38

Warning: The energy equation could not be balanced within the specified number of iterations. The program used critical depth for the water surface and continued on with the calculations.
 Warning: The conveyance ratio (upstream conveyance divided by downstream conveyance) is less than 0.7 or greater than 1.4.
 This may indicate the need for additional cross sections.
 Warning: During the standard step iterations, when the assumed water surface was set equal to critical depth, the calculated water surface came back below critical depth. This indicates that there is not a valid subcritical answer. The program

defaulted to critical depth.

Note: Multiple critical depths were found at this location. The critical depth with the lowest, valid, water surface was used.

CROSS SECTION OUTPUT Profile #PF 14

E.G. Elev (ft)	653.85	Element	Left OB	Channel
Right OB Vel Head (ft)	1.02	wt. n-Val.		0.030
W.S. Elev (ft)	652.84	Reach Len. (ft)	10.00	10.00
10.00 Crit W.S. (ft)	652.84	Flow Area (sq ft)		24.73
E.G. Slope (ft/ft)	0.015015	Area (sq ft)		24.73
Q Total (cfs)	200.00	Flow (cfs)		200.00
Top width (ft)	12.28	Top width (ft)		12.28
Vel Total (ft/s)	8.09	Avg. Vel. (ft/s)		8.09
Max Chl Dpth (ft)	2.04	Hydr. Depth (ft)		2.01
Conv. Total (cfs)	1632.2	Conv. (cfs)		1632.2
Length wtd. (ft)	10.00	wetted Per. (ft)		16.08
Min Ch El (ft)	650.80	Shear (lb/sq ft)		1.44
Alpha 0.00	1.00	Stream Power (lb/ft s)	46.50	0.00
Frctn Loss (ft)	0.08	Cum volume (acre-ft)		0.88
C & E Loss (ft)	0.17	Cum SA (acres)		0.39

Warning: The energy equation could not be balanced within the specified number of iterations. The program used critical depth

for the water surface and continued on with the calculations.

Warning: The velocity head has changed by more than 0.5 ft (0.15 m). This may indicate the need for additional cross sections.

Warning: The conveyance ratio (upstream conveyance divided by downstream conveyance) is less than 0.7 or greater than 1.4.

This may indicate the need for additional cross sections.

Warning: During the standard step iterations, when the assumed water surface was set equal to critical depth, the calculated

water surface came back below critical depth. This indicates that there is not a valid subcritical answer. The program

defaulted to critical depth.

Note: Multiple critical depths were found at this location. The critical depth with the lowest, valid, water surface was used.

CROSS SECTION OUTPUT Profile #PF 15

E.G. Elev (ft)	654.10	Element	Left OB	Channel
Right OB Vel Head (ft)	1.09	wt. n-Val.		0.030

westTribClow.rep				
W.S. Elev (ft)	653.01	Reach Len. (ft)	10.00	10.00
10.00				
Crit W.S. (ft)	653.01	Flow Area (sq ft)		26.90
E.G. Slope (ft/ft)	0.014780	Area (sq ft)		26.90
Q Total (cfs)	225.00	Flow (cfs)		225.00
Top width (ft)	12.31	Top width (ft)		12.31
Vel Total (ft/s)	8.36	Avg. Vel. (ft/s)		8.36
Max Chl Dpth (ft)	2.21	Hydr. Depth (ft)		2.19
Conv. Total (cfs)	1850.8	Conv. (cfs)		1850.8
Length wtd. (ft)	10.00	wetted Per. (ft)		16.44
Min ch El (ft)	650.80	Shear (lb/sq ft)		1.51
Alpha	1.00	Stream Power (lb/ft s)	46.50	0.00
0.00				
Frctn Loss (ft)	0.08	Cum Volume (acre-ft)		0.96
C & E Loss (ft)	0.18	Cum SA (acres)		0.41

Warning: The energy equation could not be balanced within the specified number of iterations. The program used critical depth for the water surface and continued on with the calculations.

Warning: The velocity head has changed by more than 0.5 ft (0.15 m). This may indicate the need for additional cross sections.

Warning: The conveyance ratio (upstream conveyance divided by downstream conveyance) is less than 0.7 or greater than 1.4. This may indicate the need for additional cross sections.

Warning: During the standard step iterations, when the assumed water surface was set equal to critical depth, the calculated water surface came back below critical depth. This indicates that there is not a valid subcritical answer. The program defaulted to critical depth.

Note: Multiple critical depths were found at this location. The critical depth with the lowest, valid, water surface was used.

CROSS SECTION OUTPUT Profile #PF 16

E.G. Elev (ft)	654.34	Element	Left OB	Channel
Right OB				
Vel Head (ft)	1.18	wt. n-val.		0.030
W.S. Elev (ft)	653.16	Reach Len. (ft)	10.00	10.00
10.00				
Crit W.S. (ft)	653.16	Flow Area (sq ft)		28.71
E.G. Slope (ft/ft)	0.015043	Area (sq ft)		28.71
Q Total (cfs)	250.00	Flow (cfs)		250.00
Top width (ft)	12.33	Top width (ft)		12.33
Vel Total (ft/s)	8.71	Avg. Vel. (ft/s)		8.71

WestTribClow.rep

Max Chl Dpth (ft)	2.36	Hydr. Depth (ft)		2.33
Conv. Total (cfs)	2038.3	Conv. (cfs)		2038.3
Length Wtd. (ft)	10.00	wetted Per. (ft)		16.73
Min Ch El (ft)	650.80	Shear (lb/sq ft)		1.61
Alpha 0.00	1.00	Stream Power (lb/ft s)	46.50	0.00
Frctn Loss (ft)	0.08	Cum Volume (acre-ft)		1.03
C & E Loss (ft)	0.20	Cum SA (acres)		0.42

Warning: The energy equation could not be balanced within the specified number of iterations. The program used critical depth for the water surface and continued on with the calculations.
 Warning: The velocity head has changed by more than 0.5 ft (0.15 m). This may indicate the need for additional cross sections.
 Warning: The conveyance ratio (upstream conveyance divided by downstream conveyance) is less than 0.7 or greater than 1.4. This may indicate the need for additional cross sections.
 Warning: During the standard step iterations, when the assumed water surface was set equal to critical depth, the calculated water surface came back below critical depth. This indicates that there is not a valid subcritical answer. The program defaulted to critical depth.
 Note: Multiple critical depths were found at this location. The critical depth with the lowest, valid, water surface was used.

CROSS SECTION OUTPUT Profile #PF 17

E.G. Elev (ft)	654.57	Element	Left OB	Channel
Right OB Vel Head (ft)	1.25	wt. n-val.		0.030
W.S. Elev (ft)	653.31	Reach Len. (ft)	10.00	10.00
10.00 Crit w.s. (ft)	653.31	Flow Area (sq ft)		30.59
E.G. slope (ft/ft)	0.015096	Area (sq ft)		30.59
Q Total (cfs)	275.00	Flow (cfs)		275.00
Top width (ft)	12.35	Top width (ft)		12.35
Vel Total (ft/s)	8.99	Avg. vel. (ft/s)		8.99
Max Chl Dpth (ft)	2.51	Hydr. Depth (ft)		2.48
Conv. Total (cfs)	2238.2	Conv. (cfs)		2238.2
Length Wtd. (ft)	10.00	wetted Per. (ft)		17.04
Min Ch El (ft)	650.80	Shear (lb/sq ft)		1.69
Alpha 0.00	1.00	Stream Power (lb/ft s)	46.50	0.00

	westTribClow.rep		
Frctn Loss (ft)	0.07	Cum Volume (acre-ft)	1.11
C & E Loss (ft)	0.21	Cum SA (acres)	0.43

Warning: The energy equation could not be balanced within the specified number of iterations. The program used critical depth for the water surface and continued on with the calculations.

Warning: The velocity head has changed by more than 0.5 ft (0.15 m). This may indicate the need for additional cross sections.

Warning: The conveyance ratio (upstream conveyance divided by downstream conveyance) is less than 0.7 or greater than 1.4. This may indicate the need for additional cross sections.

Warning: The energy loss was greater than 1.0 ft (0.3 m). between the current and previous cross section. This may indicate the need for additional cross sections.

Warning: During the standard step iterations, when the assumed water surface was set equal to critical depth, the calculated water surface came back below critical depth. This indicates that there is not a valid subcritical answer. The program defaulted to critical depth.

Note: Multiple critical depths were found at this location. The critical depth with the lowest, valid, water surface was used.

CROSS SECTION OUTPUT Profile #PF 18

E.G. Elev (ft)	654.79	Element	Left OB	Channel
Right OB				
Vel Head (ft)	1.31	wt. n-Val.		0.030
w.s. Elev (ft)	653.48	Reach Len. (ft)	10.00	10.00
10.00				
Crit w.s. (ft)	653.48	Flow Area (sq ft)		32.65
E.G. Slope (ft/ft)	0.014832	Area (sq ft)		32.65
Q Total (cfs)	300.00	Flow (cfs)		300.00
Top width (ft)	12.37	Top width (ft)		12.37
Vel Total (ft/s)	9.19	Avg. Vel. (ft/s)		9.19
Max Chl Dpth (ft)	2.68	Hydr. Depth (ft)		2.64
Conv. Total (cfs)	2463.3	Conv. (cfs)		2463.3
Length wtd. (ft)	10.00	wetted Per. (ft)		17.37
Min Ch El (ft)	650.80	Shear (lb/sq ft)		1.74
Alpha	1.00	Stream Power (lb/ft s)	46.50	0.00
0.00				
Frctn Loss (ft)	0.07	Cum Volume (acre-ft)		1.18
C & E Loss (ft)	0.22	Cum SA (acres)		0.44

Warning: The energy equation could not be balanced within the specified number of iterations.
Page 49

iterations. The program used critical depth for the water surface and continued on with the calculations.
 Warning: The velocity head has changed by more than 0.5 ft (0.15 m). This may indicate the need for additional cross sections.
 Warning: The conveyance ratio (upstream conveyance divided by downstream conveyance) is less than 0.7 or greater than 1.4. This may indicate the need for additional cross sections.
 Warning: The energy loss was greater than 1.0 ft (0.3 m). between the current and previous cross section. This may indicate the need for additional cross sections.
 Warning: During the standard step iterations, when the assumed water surface was set equal to critical depth, the calculated water surface came back below critical depth. This indicates that there is not a valid subcritical answer. The program defaulted to critical depth.
 Note: Multiple critical depths were found at this location. The critical depth with the lowest, valid, water surface was used.

CROSS SECTION OUTPUT Profile #PF 19

E.G. Elev (ft)	655.01	Element	Left OB	Channel
Right OB				
Vel Head (ft)	1.39	wt. n-Val.		0.030
w.S. Elev (ft)	653.62	Reach Len. (ft)	10.00	10.00
10.00				
Crit w.S. (ft)	653.62	Flow Area (sq ft)		34.35
E.G. Slope (ft/ft)	0.015015	Area (sq ft)		34.35
Q Total (cfs)	325.00	Flow (cfs)		325.00
Top width (ft)	12.39	Top width (ft)		12.39
Vel Total (ft/s)	9.46	Avg. Vel. (ft/s)		9.46
Max Chl Dpth (ft)	2.82	Hydr. Depth (ft)		2.77
Conv. Total (cfs)	2652.2	Conv. (cfs)		2652.2
Length wtd. (ft)	10.00	wetted Per. (ft)		17.65
Min Ch El (ft)	650.80	Shear (lb/sq ft)		1.82
Alpha	1.00	Stream Power (lb/ft s)	46.50	0.00
0.00				
Frctn Loss (ft)	0.07	Cum Volume (acre-ft)	0.00	1.25
0.00				
C & E Loss (ft)	0.23	Cum SA (acres)	0.00	0.45
0.00				

Warning: The energy equation could not be balanced within the specified number of iterations. The program used critical depth for the water surface and continued on with the calculations.
 warning: The velocity head has changed by more than 0.5 ft (0.15 m). This may indicate the need for additional cross sections.
 warning: The conveyance ratio (upstream conveyance divided by downstream conveyance) is less than 0.7 or greater than 1.4. This may indicate the need for additional cross sections.
 warning: The energy loss was greater than 1.0 ft (0.3 m). between the current and

previous cross section. This may indicate the need for additional cross sections.
 Warning: During the standard step iterations, when the assumed water surface was set equal to critical depth, the calculated water surface came back below critical depth. This indicates that there is not a valid subcritical answer. The program defaulted to critical depth.
 Note: Multiple critical depths were found at this location. The critical depth with the lowest, valid, water surface was used.

CROSS SECTION OUTPUT Profile #PF 20

E.G. Elev (ft)	655.22	Element	Left OB	Channel
Right OB				
Vel Head (ft)	1.46	wt. n-val.		0.030
W.S. Elev (ft)	653.76	Reach Len. (ft)	10.00	10.00
10.00				
Crit W.S. (ft)	653.76	Flow Area (sq ft)		36.11
E.G. slope (ft/ft)	0.015059	Area (sq ft)		36.11
Q Total (cfs)	350.00	Flow (cfs)		350.00
Top width (ft)	12.41	Top width (ft)		12.41
vel Total (ft/s)	9.69	Avg. vel. (ft/s)		9.69
Max Chl Dpth (ft)	2.96	Hydr. Depth (ft)		2.91
Conv. Total (cfs)	2852.2	Conv. (cfs)		2852.2
Length wtd. (ft)	10.00	wetted Per. (ft)		17.93
Min Ch El (ft)	650.80	Shear (lb/sq ft)		1.89
Alpha	1.00	Stream Power (lb/ft s)	46.50	0.00
0.00				
Frctn Loss (ft)	0.07	Cum volume (acre-ft)	0.00	1.31
0.00				
C & E Loss (ft)	0.24	Cum SA (acres)	0.00	0.45
0.01				

Warning: The energy equation could not be balanced within the specified number of iterations. The program used critical depth for the water surface and continued on with the calculations.
 Warning: The velocity head has changed by more than 0.5 ft (0.15 m). This may indicate the need for additional cross sections.
 Warning: The conveyance ratio (upstream conveyance divided by downstream conveyance) is less than 0.7 or greater than 1.4. This may indicate the need for additional cross sections.
 Warning: The energy loss was greater than 1.0 ft (0.3 m). between the current and previous cross section. This may indicate the need for additional cross sections.
 Warning: During the standard step iterations, when the assumed water surface was set equal to critical depth, the calculated water surface came back below critical depth. This indicates that there is not a valid subcritical answer. The program defaulted to critical depth.
 Note: Multiple critical depths were found at this location. The critical depth

with the lowest, valid, water surface was used.

CROSS SECTION OUTPUT Profile #PF 21

E.G. Elev (ft)	655.42	Element	Left OB	Channel
Right OB Vel Head (ft)	1.53	wt. n-val.		0.030
W.S. Elev (ft)	653.90	Reach Len. (ft)	10.00	10.00
10.00 Crit w.s. (ft)	653.90	Flow Area (sq ft)		37.81
E.G. slope (ft/ft)	0.015129	Area (sq ft)		37.81
Q Total (cfs)	375.00	Flow (cfs)		375.00
Top width (ft)	12.43	Top width (ft)		12.43
Vel Total (ft/s)	9.92	Avg. vel. (ft/s)		9.92
Max chl Dpth (ft)	3.10	Hydr. Depth (ft)		3.04
Conv. Total (cfs)	3048.8	Conv. (cfs)		3048.8
Length wtd. (ft)	10.00	wetted Per. (ft)		18.21
Min ch El (ft)	650.80	Shear (lb/sq ft)		1.96
Alpha 0.00	1.00	Stream Power (lb/ft s)	46.50	0.00
Frctn Loss (ft)	0.07	Cum Volume (acre-ft)	0.00	1.38
0.00 C & E Loss (ft)	0.25	Cum SA (acres)	0.00	0.46
0.01				

Warning: The energy equation could not be balanced within the specified number of iterations. The program used critical depth for the water surface and continued on with the calculations.

Warning: The velocity head has changed by more than 0.5 ft (0.15 m). This may indicate the need for additional cross sections.

Warning: The conveyance ratio (upstream conveyance divided by downstream conveyance) is less than 0.7 or greater than 1.4. This may indicate the need for additional cross sections.

Warning: The energy loss was greater than 1.0 ft (0.3 m). between the current and previous cross section. This may indicate the need for additional cross sections.

Warning: During the standard step iterations, when the assumed water surface was set equal to critical depth, the calculated water surface came back below critical depth. This indicates that there is not a valid subcritical answer. The program defaulted to critical depth.

Note: Multiple critical depths were found at this location. The critical depth with the lowest, valid, water surface was used.

CROSS SECTION OUTPUT Profile #PF 22

E.G. Elev (ft)	655.62	Element	Left OB	Channel
Right OB Vel Head (ft)	1.58	wt. n-val.		0.030

WestTribClow.rep

W.S. Elev (ft) 10.00	654.04	Reach Len. (ft)	10.00	10.00
Crit w.s. (ft)	654.04	Flow Area (sq ft)		39.62
E.G. Slope (ft/ft)	0.015051	Area (sq ft)		39.62
Q Total (cfs)	400.00	Flow (cfs)		400.00
Top width (ft)	12.45	Top width (ft)		12.45
Vel Total (ft/s)	10.10	Avg. Vel. (ft/s)		10.10
Max Chl Dpth (ft)	3.24	Hydr. Depth (ft)		3.18
Conv. Total (cfs)	3260.5	Conv. (cfs)		3260.5
Length wtd. (ft)	10.00	wetted Per. (ft)		18.50
Min Ch El (ft)	650.80	Shear (lb/sq ft)		2.01
Alpha 0.00	1.00	Stream Power (lb/ft s)	46.50	0.00
Frctn Loss (ft) 0.00	0.07	Cum Volume (acre-ft)	0.00	1.45
C & E Loss (ft) 0.01	0.26	Cum SA (acres)	0.00	0.47

Warning: The energy equation could not be balanced within the specified number of iterations. The program used critical depth for the water surface and continued on with the calculations.

Warning: The velocity head has changed by more than 0.5 ft (0.15 m). This may indicate the need for additional cross sections.

Warning: The conveyance ratio (upstream conveyance divided by downstream conveyance) is less than 0.7 or greater than 1.4. This may indicate the need for additional cross sections.

Warning: The energy loss was greater than 1.0 ft (0.3 m) between the current and previous cross section. This may indicate the need for additional cross sections.

Warning: During the standard step iterations, when the assumed water surface was set equal to critical depth, the calculated water surface came back below critical depth. This indicates that there is not a valid subcritical answer. The program defaulted to critical depth.

Note: Multiple critical depths were found at this location. The critical depth with the lowest, valid, water surface was used.

CROSS SECTION OUTPUT Profile #PF 23

E.G. Elev (ft)	655.82	Element	Left OB	Channel
Right OB Vel Head (ft)	1.66	Wt. n-val.		0.030
W.S. Elev (ft) 10.00	654.16	Reach Len. (ft)	10.00	10.00
Crit w.s. (ft)	654.16	Flow Area (sq ft)		41.13
E.G. Slope (ft/ft)	0.015256	Area (sq ft)		41.13
Q Total (cfs)	425.00	Flow (cfs)		425.00

westTribClow.rep

Top Width (ft)	12.47	Top Width (ft)	12.47
Vel Total (ft/s)	10.33	Avg. Vel. (ft/s)	10.33
Max Chl Dpth (ft)	3.36	Hydr. Depth (ft)	3.30
Conv. Total (cfs)	3440.9	Conv. (cfs)	3440.9
Length wtd. (ft)	10.00	wetted Per. (ft)	18.74
Min Ch El (ft)	650.80	Shear (lb/sq ft)	2.09
Alpha	1.00	Stream Power (lb/ft s)	46.50
0.00			0.00
Frctn Loss (ft)	0.07	Cum Volume (acre-ft)	0.00
0.01			1.51
C & E Loss (ft)	0.27	Cum SA (acres)	0.00
0.02			0.48

Warning: The energy equation could not be balanced within the specified number of iterations. The program used critical depth for the water surface and continued on with the calculations.

Warning: The velocity head has changed by more than 0.5 ft (0.15 m). This may indicate the need for additional cross sections.

Warning: The conveyance ratio (upstream conveyance divided by downstream conveyance) is less than 0.7 or greater than 1.4. This may indicate the need for additional cross sections.

Warning: The energy loss was greater than 1.0 ft (0.3 m). between the current and previous cross section. This may indicate the need for additional cross sections.

Warning: During the standard step iterations, when the assumed water surface was set equal to critical depth, the calculated water surface came back below critical depth. This indicates that there is not a valid subcritical answer. The program defaulted to critical depth.

Note: Multiple critical depths were found at this location. The critical depth with the lowest, valid, water surface was used.

CROSS SECTION OUTPUT Profile #PF 24

E.G. Elev (ft)	656.01	Element	Left OB	Channel
Right OB				
Vel Head (ft)	1.71	wt. n-Val.		0.030
w.s. Elev (ft)	654.30	Reach Len. (ft)	10.00	10.00
10.00				
Crit w.s. (ft)	654.30	Flow Area (sq ft)		42.86
E.G. Slope (ft/ft)	0.015205	Area (sq ft)		42.86
Q Total (cfs)	450.00	Flow (cfs)		450.00
Top width (ft)	12.49	Top width (ft)		12.49
Vel Total (ft/s)	10.50	Avg. Vel. (ft/s)		10.50
Max Chl Dpth (ft)	3.50	Hydr. Depth (ft)		3.43
Conv. Total (cfs)	3649.4	Conv. (cfs)		3649.4

WestTribClow.rep

Length Wtd. (ft)	10.00	Wetted Per. (ft)		19.02
Min Ch El (ft)	650.80	Shear (lb/sq ft)		2.14
Alpha 0.00	1.00	Stream Power (lb/ft s)	46.50	0.00
Frctn Loss (ft) 0.01	0.07	Cum Volume (acre-ft)	0.15	1.58
C & E Loss (ft) 0.02	0.28	Cum SA (acres)	0.35	0.49

Warning: The energy equation could not be balanced within the specified number of iterations. The program used critical depth for the water surface and continued on with the calculations.

Warning: The velocity head has changed by more than 0.5 ft (0.15 m). This may indicate the need for additional cross sections.

Warning: The conveyance ratio (upstream conveyance divided by downstream conveyance) is less than 0.7 or greater than 1.4. This may indicate the need for additional cross sections.

Warning: The energy loss was greater than 1.0 ft (0.3 m). between the current and previous cross section. This may indicate the need for additional cross sections.

Warning: During the standard step iterations, when the assumed water surface was set equal to critical depth, the calculated water surface came back below critical depth. This indicates that there is not a valid subcritical answer. The program defaulted to critical depth.

Note: Multiple critical depths were found at this location. The critical depth with the lowest, valid, water surface was used.

CROSS SECTION OUTPUT Profile #PF 25

E.G. Elev (ft)	656.20	Element	Left OB	Channel
Right OB Vel Head (ft)	1.77	wt. n-val.		0.030
W.S. Elev (ft)	654.43	Reach Len. (ft)	10.00	10.00
10.00 Crit W.S. (ft)	654.43	Flow Area (sq ft)		44.48
E.G. Slope (ft/ft)	0.015248	Area (sq ft)		44.48
Q Total (cfs)	475.00	Flow (cfs)		475.00
Top Width (ft)	12.50	Top Width (ft)		12.50
Vel Total (ft/s)	10.68	Avg. Vel. (ft/s)		10.68
Max Chl Dpth (ft)	3.63	Hydr. Depth (ft)		3.56
Conv. Total (cfs)	3846.7	Conv. (cfs)		3846.7
Length Wtd. (ft)	10.00	wetted Per. (ft)		19.28
Min Ch El (ft)	650.80	Shear (lb/sq ft)		2.20
Alpha 0.00	1.00	Stream Power (lb/ft s)	46.50	0.00
Frctn Loss (ft)	0.07	Cum Volume (acre-ft)	0.26	1.63

WestTribClow.rep

0.03				
C & E Loss (ft)	0.28	Cum SA (acres)	0.58	0.49
0.17				

Warning: The energy equation could not be balanced within the specified number of iterations. The program used critical depth for the water surface and continued on with the calculations.

Warning: The velocity head has changed by more than 0.5 ft (0.15 m). This may indicate the need for additional cross sections.

Warning: The conveyance ratio (upstream conveyance divided by downstream conveyance) is less than 0.7 or greater than 1.4. This may indicate the need for additional cross sections.

Warning: The energy loss was greater than 1.0 ft (0.3 m) between the current and previous cross section. This may indicate the need for additional cross sections.

Warning: During the standard step iterations, when the assumed water surface was set equal to critical depth, the calculated water surface came back below critical depth. This indicates that there is not a valid subcritical answer. The program defaulted to critical depth.

Note: Multiple critical depths were found at this location. The critical depth with the lowest, valid, water surface was used.

CROSS SECTION OUTPUT Profile #PF 26

E.G. Elev (ft)	656.39	Element	Left OB	Channel
Right OB				
Vel Head (ft)	1.83	wt. n-val.		0.030
W.S. Elev (ft)	654.56	Reach Len. (ft)	10.00	10.00
10.00				
Crit w.s. (ft)	654.56	Flow Area (sq ft)		46.10
E.G. slope (ft/ft)	0.015267	Area (sq ft)		46.10
Q Total (cfs)	500.00	Flow (cfs)		500.00
Top width (ft)	12.52	Top width (ft)		12.52
Vel Total (ft/s)	10.85	Avg. vel. (ft/s)		10.85
Max Chl Dpth (ft)	3.76	Hydr. Depth (ft)		3.68
Conv. Total (cfs)	4046.7	Conv. (cfs)		4046.7
Length Wtd. (ft)	10.00	wetted Per. (ft)		19.54
Min Ch El (ft)	650.80	Shear (lb/sq ft)		2.25
Alpha	1.00	Stream Power (lb/ft s)	46.50	0.00
0.00				
Frctn Loss (ft)	0.07	Cum volume (acre-ft)	0.35	1.68
0.20				
C & E Loss (ft)	0.28	Cum SA (acres)	0.66	0.49
0.56				

Warning: The energy equation could not be balanced within the specified number of iterations. The program used critical depth

for the water surface and continued on with the calculations.
 Warning: The velocity head has changed by more than 0.5 ft (0.15 m). This may indicate the need for additional cross sections.
 Warning: The conveyance ratio (upstream conveyance divided by downstream conveyance) is less than 0.7 or greater than 1.4.
 This may indicate the need for additional cross sections.
 Warning: The energy loss was greater than 1.0 ft (0.3 m). between the current and previous cross section. This may indicate the need for additional cross sections.
 Warning: During the standard step iterations, when the assumed water surface was set equal to critical depth, the calculated water surface came back below critical depth. This indicates that there is not a valid subcritical answer. The program defaulted to critical depth.
 Note: Multiple critical depths were found at this location. The critical depth with the lowest, valid, water surface was used.

CROSS SECTION OUTPUT Profile #PF 27

E.G. Elev (ft)	656.57	Element	Left OB	Channel
Right OB				
Vel Head (ft)	1.89	wt. n-val.		0.030
W.S. Elev (ft)	654.68	Reach Len. (ft)	10.00	10.00
10.00				
Crit w.s. (ft)	654.68	Flow Area (sq ft)		47.60
E.G. Slope (ft/ft)	0.015370	Area (sq ft)		47.60
Q Total (cfs)	525.00	Flow (cfs)		525.00
Top width (ft)	12.54	Top width (ft)		12.54
Vel Total (ft/s)	11.03	Avg. Vel. (ft/s)		11.03
Max Chl Dpth (ft)	3.88	Hydr. Depth (ft)		3.80
Conv. Total (cfs)	4234.7	conv. (cfs)		4234.7
Length wtd. (ft)	10.00	wetted Per. (ft)		19.78
Min Ch El (ft)	650.80	Shear (lb/sq ft)		2.31
Alpha	1.00	Stream Power (lb/ft s)	46.50	0.00
0.00				
Frctn Loss (ft)	0.08	Cum Volume (acre-ft)	0.74	1.72
0.29				
C & E Loss (ft)	0.28	Cum SA (acres)	1.83	0.50
0.73				

Warning: The energy equation could not be balanced within the specified number of iterations. The program used critical depth for the water surface and continued on with the calculations.
 Warning: The velocity head has changed by more than 0.5 ft (0.15 m). This may indicate the need for additional cross sections.
 Warning: The conveyance ratio (upstream conveyance divided by downstream conveyance) is less than 0.7 or greater than 1.4.
 This may indicate the need for additional cross sections.
 Warning: The energy loss was greater than 1.0 ft (0.3 m). between the current and previous cross section. This may indicate the

need for additional cross sections.

Warning: During the standard step iterations, when the assumed water surface was set equal to critical depth, the calculated water surface came back below critical depth. This indicates that there is not a valid subcritical answer. The program defaulted to critical depth.

Note: Multiple critical depths were found at this location. The critical depth with the lowest, valid, water surface was used.

CROSS SECTION OUTPUT Profile #PF 28

E.G. Elev (ft)	656.75	Element	Left OB	Channel
Right OB Vel Head (ft)	1.96	wt. n-Val.		0.030
W.S. Elev (ft)	654.79	Reach Len. (ft)	10.00	10.00
10.00 Crit W.S. (ft)	654.79	Flow Area (sq ft)		48.96
E.G. Slope (ft/ft)	0.015589	Area (sq ft)		48.96
Q Total (cfs)	550.00	Flow (cfs)		550.00
Top width (ft)	12.55	Top width (ft)		12.55
Vel Total (ft/s)	11.23	Avg. Vel. (ft/s)		11.23
Max Chl Dpth (ft)	3.99	Hydr. Depth (ft)		3.90
Conv. Total (cfs)	4405.1	Conv. (cfs)		4405.1
Length wtd. (ft)	10.00	wetted Per. (ft)		19.99
Min Ch El (ft)	650.80	Shear (lb/sq ft)		2.38
Alpha 0.00	1.00	Stream Power (lb/ft s)	46.50	0.00
Frctn Loss (ft)	0.08	Cum Volume (acre-ft)	0.94	1.76
0.68 C & E Loss (ft)	0.26	Cum SA (acres)	2.02	0.50
1.22				

Warning: The energy equation could not be balanced within the specified number of iterations. The program used critical depth

for the water surface and continued on with the calculations.

Warning: The velocity head has changed by more than 0.5 ft (0.15 m). This may indicate the need for additional cross sections.

Warning: The conveyance ratio (upstream conveyance divided by downstream conveyance) is less than 0.7 or greater than 1.4.

This may indicate the need for additional cross sections.

Warning: The energy loss was greater than 1.0 ft (0.3 m). between the current and previous cross section. This may indicate the

need for additional cross sections.

Warning: During the standard step iterations, when the assumed water surface was set equal to critical depth, the calculated

water surface came back below critical depth. This indicates that there is not a valid subcritical answer. The program

defaulted to critical depth.

Note: Multiple critical depths were found at this location. The critical depth with the lowest, valid, water surface was used.

WestTribClow.rep

CROSS SECTION OUTPUT Profile #PF 29

E.G. Elev (ft)	656.92	Element	Left OB	Channel
Right OB Vel Head (ft)	2.02	wt. n-Val.		0.030
W.S. Elev (ft)	654.91	Reach Len. (ft)	10.00	10.00
10.00 Crit W.S. (ft)	654.91	Flow Area (sq ft)		50.45
E.G. Slope (ft/ft)	0.015661	Area (sq ft)		50.45
Q Total (cfs)	575.00	Flow (cfs)		575.00
Top width (ft)	12.57	Top width (ft)		12.57
Vel Total (ft/s)	11.40	Avg. Vel. (ft/s)		11.40
Max Chl Dpth (ft)	4.11	Hydr. Depth (ft)		4.01
Conv. Total (cfs)	4594.7	Conv. (cfs)		4594.7
Length wtd. (ft)	10.00	wetted Per. (ft)		20.23
Min Ch El (ft)	650.80	Shear (lb/sq ft)		2.44
Alpha	1.00	Stream Power (lb/ft s)	46.50	0.00
0.00 Frctn Loss (ft)	0.09	Cum volume (acre-ft)	1.10	1.79
0.84 C & E Loss (ft)	0.26	Cum SA (acres)	2.09	0.50
1.55				

Warning: The energy equation could not be balanced within the specified number of iterations. The program used critical depth

for the water surface and continued on with the calculations.

Warning: The velocity head has changed by more than 0.5 ft (0.15 m). This may indicate the need for additional cross sections.

Warning: The conveyance ratio (upstream conveyance divided by downstream conveyance) is less than 0.7 or greater than 1.4.

This may indicate the need for additional cross sections.

Warning: The energy loss was greater than 1.0 ft (0.3 m). between the current and previous cross section. This may indicate the need for additional cross sections.

Warning: During the standard step iterations, when the assumed water surface was set equal to critical depth, the calculated water surface came back below critical depth. This indicates that there is not a valid subcritical answer. The program defaulted to critical depth.

Note: Multiple critical depths were found at this location. The critical depth with the lowest, valid, water surface was used.

CROSS SECTION OUTPUT Profile #PF 30

E.G. Elev (ft)	657.10	Element	Left OB	Channel
Right OB Vel Head (ft)	2.07	wt. n-Val.		0.030

westTribClow.rep				
W.S. Elev (ft)	655.02	Reach Len. (ft)	10.00	10.00
10.00				
Crit w.s. (ft)	655.02	Flow Area (sq ft)		51.94
E.G. slope (ft/ft)	0.015719	Area (sq ft)		51.94
Q Total (cfs)	600.00	Flow (cfs)		600.00
Top width (ft)	12.59	Top width (ft)		12.59
Vel Total (ft/s)	11.55	Avg. Vel. (ft/s)		11.55
Max Chl Dpth (ft)	4.22	Hydr. Depth (ft)		4.13
Conv. Total (cfs)	4785.7	Conv. (cfs)		4785.7
Length wtd. (ft)	10.00	wetted Per. (ft)		20.47
Min ch El (ft)	650.80	Shear (lb/sq ft)		2.49
Alpha	1.00	Stream Power (lb/ft s)	46.50	0.00
0.00				
Frctn Loss (ft)	0.09	Cum Volume (acre-ft)	1.28	1.82
0.95				
C & E Loss (ft)	0.25	Cum SA (acres)	2.16	0.51
1.64				

Warning: The energy equation could not be balanced within the specified number of iterations. The program used critical depth for the water surface and continued on with the calculations.

Warning: The velocity head has changed by more than 0.5 ft (0.15 m). This may indicate the need for additional cross sections.

Warning: The conveyance ratio (upstream conveyance divided by downstream conveyance) is less than 0.7 or greater than 1.4. This may indicate the need for additional cross sections.

Warning: The energy loss was greater than 1.0 ft (0.3 m) between the current and previous cross section. This may indicate the need for additional cross sections.

Warning: During the standard step iterations, when the assumed water surface was set equal to critical depth, the calculated water surface came back below critical depth. This indicates that there is not a valid subcritical answer. The program defaulted to critical depth.

Note: Multiple critical depths were found at this location. The critical depth with the lowest, valid, water surface was used.

CROSS SECTION

RIVER: WestTribClow
 REACH: WestTribClow RS: 1777

INPUT

Description: 17+77

Station Elevation Data num= 22									
Sta	Elev	Sta	Elev	Sta	Elev	Sta	Elev	Sta	Elev
-55	658	-30	657	-24	656	-18.5	655	-17	654.8
-15.5	654	-14.5	653	-11.5	652	-7.5	651	-5	650.3
0	650	2.5	650	6.5	650.4	7.5	651	9	652
10.5	653	12	654	16.5	654.5	20	655	27	656
31.5	657	41	658						

WestTribClow.rep

Manning's n Values num= 3
 Sta n Val Sta n Val Sta n Val
 -55 .08 -17 .03 12 .08

Bank Sta: Left Right Lengths: Left Channel Right Coeff Contr. Expan.
 -17 12 114 68 87 .1 .3
 Ineffective Flow num= 2
 Sta L Sta R Elev Permanent
 -55 -9 658.1 F
 9 41 658.6 F

CROSS SECTION OUTPUT Profile #PF 1

E.G. Elev (ft)	650.59	Element	Left OB	Channel
Right OB Vel Head (ft)	0.08	wt. n-Val.		0.030
w.s. Elev (ft)	650.50	Reach Len. (ft)	114.00	68.00
87.00 Crit w.s. (ft)	650.42	Flow Area (sq ft)		4.31
E.G. Slope (ft/ft)	0.009080	Area (sq ft)		4.31
Q Total (cfs)	10.00	Flow (cfs)		10.00
Top width (ft)	12.39	Top width (ft)		12.39
Vel Total (ft/s)	2.32	Avg. Vel. (ft/s)		2.32
Max Chl Dpth (ft)	0.50	Hydr. Depth (ft)		0.35
Conv. Total (cfs)	104.9	Conv. (cfs)		104.9
Length wtd. (ft)	68.00	wetted Per. (ft)		12.48
Min Ch El (ft)	650.00	Shear (lb/sq ft)		0.20
Alpha	1.00	Stream Power (lb/ft s)	41.00	0.00
0.00 Frctn Loss (ft)	0.51	Cum Volume (acre-ft)		0.10
C & E Loss (ft)	0.01	Cum SA (acres)		0.19

Note: Multiple critical depths were found at this location. The critical depth with the lowest, valid, energy was used.

CROSS SECTION OUTPUT Profile #PF 2

E.G. Elev (ft)	650.83	Element	Left OB	Channel
Right OB Vel Head (ft)	0.13	wt. n-Val.		0.030
w.s. Elev (ft)	650.70	Reach Len. (ft)	114.00	68.00
87.00 Crit w.s. (ft)	650.59	Flow Area (sq ft)		6.83
E.G. slope (ft/ft)	0.008748	Area (sq ft)		6.83

westTribClow.rep

Q Total (cfs)	20.00	Flow (cfs)		20.00
Top width (ft)	13.42	Top width (ft)		13.42
Vel Total (ft/s)	2.93	Avg. Vel. (ft/s)		2.93
Max Chl Dpth (ft)	0.70	Hydr. Depth (ft)		0.51
Conv. Total (cfs)	213.8	Conv. (cfs)		213.8
Length wtd. (ft)	68.00	wetted Per. (ft)		13.58
Min Ch El (ft)	650.00	Shear (lb/sq ft)		0.27
Alpha 0.00	1.00	Stream Power (lb/ft s)	41.00	0.00
Frctn Loss (ft)	0.45	Cum Volume (acre-ft)		0.17
C & E Loss (ft)	0.02	Cum SA (acres)		0.23

Note: Multiple critical depths were found at this location. The critical depth with the lowest, valid, energy was used.

CROSS SECTION OUTPUT Profile #PF 3

E.G. Elev (ft)	651.02	Element	Left OB	Channel
Right OB Vel Head (ft)	0.18	wt. n-val.		0.030
W.S. Elev (ft)	650.84	Reach Len. (ft)	114.00	68.00
87.00 Crit W.S. (ft)	650.72	Flow Area (sq ft)		8.76
E.G. Slope (ft/ft)	0.009246	Area (sq ft)		8.76
Q Total (cfs)	30.00	Flow (cfs)		30.00
Top width (ft)	14.15	Top width (ft)		14.15
Vel Total (ft/s)	3.42	Avg. Vel. (ft/s)		3.42
Max Chl Dpth (ft)	0.84	Hydr. Depth (ft)		0.62
Conv. Total (cfs)	312.0	Conv. (cfs)		312.0
Length wtd. (ft)	68.00	wetted Per. (ft)		14.37
Min Ch El (ft)	650.00	Shear (lb/sq ft)		0.35
Alpha 0.00	1.00	Stream Power (lb/ft s)	41.00	0.00
Frctn Loss (ft)	0.40	Cum Volume (acre-ft)		0.23
C & E Loss (ft)	0.03	Cum SA (acres)		0.26

Warning: The conveyance ratio (upstream conveyance divided by downstream conveyance) is less than 0.7 or greater than 1.4.

This may indicate the need for additional cross sections.

Note: Multiple critical depths were found at this location. The critical depth with the lowest, valid, energy was used.

CROSS SECTION OUTPUT Profile #PF 4

E.G. Elev (ft)	651.18	Element	Left OB	Channel
Right OB Vel Head (ft)	0.24	wt. n-Val.		0.030
W.S. Elev (ft)	650.94	Reach Len. (ft)	114.00	68.00
87.00 Crit w.s. (ft)	650.85	Flow Area (sq ft)		10.17
E.G. Slope (ft/ft)	0.010505	Area (sq ft)		10.17
Q Total (cfs)	40.00	Flow (cfs)		40.00
Top width (ft)	14.66	Top width (ft)		14.66
Vel Total (ft/s)	3.93	Avg. Vel. (ft/s)		3.93
Max Chl Dpth (ft)	0.94	Hydr. Depth (ft)		0.69
Conv. Total (cfs)	390.3	Conv. (cfs)		390.3
Length wtd. (ft)	68.00	wetted Per. (ft)		14.93
Min Ch El (ft)	650.00	Shear (lb/sq ft)		0.45
Alpha 0.00	1.00	Stream Power (lb/ft s)	41.00	0.00
Frctn Loss (ft)	0.36	Cum Volume (acre-ft)		0.28
C & E Loss (ft)	0.05	Cum SA (acres)		0.28

Warning: The conveyance ratio (upstream conveyance divided by downstream conveyance) is less than 0.7 or greater than 1.4.

This may indicate the need for additional cross sections.

Note: Multiple critical depths were found at this location. The critical depth with the lowest, valid, energy was used.

CROSS SECTION OUTPUT Profile #PF 5

E.G. Elev (ft)	651.32	Element	Left OB	Channel
Right OB Vel Head (ft)	0.28	wt. n-Val.		0.030
W.S. Elev (ft)	651.04	Reach Len. (ft)	114.00	68.00
87.00 Crit w.s. (ft)	650.95	Flow Area (sq ft)		11.70
E.G. Slope (ft/ft)	0.010834	Area (sq ft)		11.70
Q Total (cfs)	50.00	Flow (cfs)		50.00

westTribClow.rep				
Top width (ft)	15.21	Top width (ft)		15.21
Vel Total (ft/s)	4.27	Avg. Vel. (ft/s)		4.27
Max Chl Dpth (ft)	1.04	Hydr. Depth (ft)		0.77
Conv. Total (cfs)	480.4	Conv. (cfs)		480.4
Length wtd. (ft)	68.00	wetted Per. (ft)		15.52
Min Ch El (ft)	650.00	Shear (lb/sq ft)		0.51
Alpha	1.00	Stream Power (lb/ft s)	41.00	0.00
0.00				
Frctn Loss (ft)	0.32	Cum Volume (acre-ft)		0.33
C & E Loss (ft)	0.06	Cum SA (acres)		0.29

Warning: The conveyance ratio (upstream conveyance divided by downstream conveyance) is less than 0.7 or greater than 1.4.

This may indicate the need for additional cross sections.

Note: Multiple critical depths were found at this location. The critical depth with the lowest, valid, energy was used.

CROSS SECTION OUTPUT Profile #PF 6

E.G. Elev (ft)	651.46	Element	Left OB	Channel
Right OB				
Vel Head (ft)	0.31	wt. n-val.		0.030
W.S. Elev (ft)	651.15	Reach Len. (ft)	114.00	68.00
87.00				
Crit W.S. (ft)	651.06	Flow Area (sq ft)		13.42
E.G. Slope (ft/ft)	0.010457	Area (sq ft)		13.42
Q Total (cfs)	60.00	Flow (cfs)		60.00
Top width (ft)	15.82	Top width (ft)		15.82
Vel Total (ft/s)	4.47	Avg. Vel. (ft/s)		4.47
Max Chl Dpth (ft)	1.15	Hydr. Depth (ft)		0.85
Conv. Total (cfs)	586.7	Conv. (cfs)		586.7
Length wtd. (ft)	68.00	wetted Per. (ft)		16.17
Min Ch El (ft)	650.00	Shear (lb/sq ft)		0.54
Alpha	1.00	Stream Power (lb/ft s)	41.00	0.00
0.00				
Frctn Loss (ft)	0.29	Cum Volume (acre-ft)		0.38
C & E Loss (ft)	0.07	Cum SA (acres)		0.31

Warning: The conveyance ratio (upstream conveyance divided by downstream conveyance) is less than 0.7 or greater than 1.4.

This may indicate the need for additional cross sections.

Note: Multiple critical depths were found at this location. The critical depth with the lowest, valid, energy was used.

CROSS SECTION OUTPUT Profile #PF 7

E.G. Elev (ft)	651.59	Element	Left OB	Channel
Right OB Vel Head (ft)	0.33	wt. n-Val.		0.030
W.S. Elev (ft)	651.26	Reach Len. (ft)	114.00	68.00
87.00 Crit w.s. (ft)	651.15	Flow Area (sq ft)		15.24
E.G. Slope (ft/ft)	0.009828	Area (sq ft)		15.24
Q Total (cfs)	70.00	Flow (cfs)		70.00
Top width (ft)	16.44	Top width (ft)		16.44
Vel Total (ft/s)	4.59	Avg. Vel. (ft/s)		4.59
Max Chl Dpth (ft)	1.26	Hydr. Depth (ft)		0.93
Conv. Total (cfs)	706.1	Conv. (cfs)		706.1
Length wtd. (ft)	68.00	wetted Per. (ft)		16.84
Min Ch El (ft)	650.00	Shear (lb/sq ft)		0.56
Alpha 0.00	1.00	Stream Power (lb/ft s)	41.00	0.00
Frctn Loss (ft)	0.27	Cum Volume (acre-ft)		0.42
C & E Loss (ft)	0.07	Cum SA (acres)		0.32

Warning: The conveyance ratio (upstream conveyance divided by downstream conveyance) is less than 0.7 or greater than 1.4.

This may indicate the need for additional cross sections.

Note: Multiple critical depths were found at this location. The critical depth with the lowest, valid, energy was used.

CROSS SECTION OUTPUT Profile #PF 8

E.G. Elev (ft)	651.71	Element	Left OB	Channel
Right OB Vel Head (ft)	0.34	wt. n-Val.		0.030
W.S. Elev (ft)	651.37	Reach Len. (ft)	114.00	68.00
87.00 Crit w.s. (ft)	651.24	Flow Area (sq ft)		17.10
E.G. Slope (ft/ft)	0.009203	Area (sq ft)		17.10
Q Total (cfs)	80.00	Flow (cfs)		80.00

		westTribClow.rep	
Top width (ft)	17.05	Top width (ft)	17.05
Vel Total (ft/s)	4.68	Avg. Vel. (ft/s)	4.68
Max Chl Dpth (ft)	1.37	Hydr. Depth (ft)	1.00
Conv. Total (cfs)	833.9	Conv. (cfs)	833.9
Length wtd. (ft)	68.00	wetted Per. (ft)	17.50
Min Ch El (ft)	650.00	Shear (lb/sq ft)	0.56
Alpha 0.00	1.00	Stream Power (lb/ft s)	41.00
Frctn Loss (ft)	0.25	Cum Volume (acre-ft)	0.46
C & E Loss (ft)	0.07	Cum SA (acres)	0.32

Warning: The conveyance ratio (upstream conveyance divided by downstream conveyance) is less than 0.7 or greater than 1.4.

This may indicate the need for additional cross sections.

Note: Multiple critical depths were found at this location. The critical depth with the lowest, valid, energy was used.

CROSS SECTION OUTPUT Profile #PF 9

E.G. Elev (ft)	651.83	Element	Left OB	Channel
Right OB Vel Head (ft)	0.35	wt. n-val.		0.030
W.S. Elev (ft)	651.48	Reach Len. (ft)	114.00	68.00
87.00 Crit W.S. (ft)	651.32	Flow Area (sq ft)		18.93
E.G. Slope (ft/ft)	0.008432	Area (sq ft)		18.95
Q Total (cfs)	90.00	Flow (cfs)		90.00
Top width (ft)	17.64	Top width (ft)		17.64
Vel Total (ft/s)	4.76	Avg. Vel. (ft/s)		4.76
Max Chl Dpth (ft)	1.48	Hydr. Depth (ft)		1.10
Conv. Total (cfs)	980.1	Conv. (cfs)		980.1
Length wtd. (ft)	68.00	wetted Per. (ft)		17.70
Min Ch El (ft)	650.00	Shear (lb/sq ft)		0.56
Alpha 0.00	1.00	Stream Power (lb/ft s)	41.00	0.00
Frctn Loss (ft)	0.23	Cum Volume (acre-ft)		0.50
C & E Loss (ft)	0.08	Cum SA (acres)		0.33

Warning: The conveyance ratio (upstream conveyance divided by downstream conveyance) is less than 0.7 or greater than 1.4.

This may indicate the need for additional cross sections.

Note: Multiple critical depths were found at this location. The critical depth with the lowest, valid, energy was used.

CROSS SECTION OUTPUT Profile #PF 10

E.G. Elev (ft)	651.95	Element	Left OB	Channel
Right OB Vel Head (ft)	0.36	wt. n-Val.		0.030
W.S. Elev (ft)	651.58	Reach Len. (ft)	114.00	68.00
87.00 Crit w.s. (ft)	651.40	Flow Area (sq ft)		20.73
E.G. Slope (ft/ft)	0.007793	Area (sq ft)		20.82
Q Total (cfs)	100.00	Flow (cfs)		100.00
Top width (ft)	18.21	Top width (ft)		18.21
Vel Total (ft/s)	4.82	Avg. Vel. (ft/s)		4.82
Max Chl Dpth (ft)	1.58	Hydr. Depth (ft)		1.19
Conv. Total (cfs)	1132.8	Conv. (cfs)		1132.8
Length wtd. (ft)	68.00	wetted Per. (ft)		17.89
Min Ch El (ft)	650.00	Shear (lb/sq ft)		0.56
Alpha 0.00	1.00	Stream Power (lb/ft s)	41.00	0.00
Frctn Loss (ft)	0.22	Cum Volume (acre-ft)		0.54
C & E Loss (ft)	0.08	Cum SA (acres)		0.34

Warning: The conveyance ratio (upstream conveyance divided by downstream conveyance) is less than 0.7 or greater than 1.4.

This may indicate the need for additional cross sections.

Note: Multiple critical depths were found at this location. The critical depth with the lowest, valid, energy was used.

CROSS SECTION OUTPUT Profile #PF 11

E.G. Elev (ft)	652.22	Element	Left OB	Channel
Right OB Vel Head (ft)	0.39	wt. n-Val.		0.030
W.S. Elev (ft)	651.83	Reach Len. (ft)	114.00	68.00
87.00 Crit w.s. (ft)	651.57	Flow Area (sq ft)		25.09
E.G. Slope (ft/ft)	0.006664	Area (sq ft)		25.50
Q Total (cfs)	125.00	Flow (cfs)		125.00

		westTribClow.rep	
Top width (ft)	19.57	Top width (ft)	19.57
Vel Total (ft/s)	4.98	Avg. Vel. (ft/s)	4.98
Max Chl Dpth (ft)	1.83	Hydr. Depth (ft)	1.41
Conv. Total (cfs)	1531.2	Conv. (cfs)	1531.2
Length wtd. (ft)	68.00	wetted Per. (ft)	18.34
Min Ch El (ft)	650.00	Shear (lb/sq ft)	0.57
Alpha 0.00	1.00	Stream Power (lb/ft s)	41.00
Frctn Loss (ft)	0.20	Cum Volume (acre-ft)	0.63
C & E Loss (ft)	0.08	Cum SA (acres)	0.35

Warning: The conveyance ratio (upstream conveyance divided by downstream conveyance) is less than 0.7 or greater than 1.4.

This may indicate the need for additional cross sections.

Note: Multiple critical depths were found at this location. The critical depth with the lowest, valid, energy was used.

CROSS SECTION OUTPUT Profile #PF 12

E.G. Elev (ft)	652.47	Element	Left OB	Channel
Right OB Vel Head (ft)	0.41	wt. n-val.		0.030
W.S. Elev (ft)	652.06	Reach Len. (ft)	114.00	68.00
87.00 Crit W.S. (ft)	651.72	Flow Area (sq ft)		29.20
E.G. Slope (ft/ft)	0.005910	Area (sq ft)		30.15
Q Total (cfs)	150.00	Flow (cfs)		150.00
Top width (ft)	20.78	Top width (ft)		20.78
Vel Total (ft/s)	5.14	Avg. Vel. (ft/s)		5.14
Max Chl Dpth (ft)	2.06	Hydr. Depth (ft)		1.62
Conv. Total (cfs)	1951.2	Conv. (cfs)		1951.2
Length wtd. (ft)	68.00	wetted Per. (ft)		18.64
Min Ch El (ft)	650.00	Shear (lb/sq ft)		0.58
Alpha 0.00	1.00	Stream Power (lb/ft s)	41.00	0.00
Frctn Loss (ft)	0.18	Cum Volume (acre-ft)		0.72
C & E Loss (ft)	0.08	Cum SA (acres)		0.37

Warning: The conveyance ratio (upstream conveyance divided by downstream conveyance) is less than 0.7 or greater than 1.4.

This may indicate the need for additional cross sections.

Note: Multiple critical depths were found at this location. The critical depth with the lowest, valid, energy was used.

CROSS SECTION OUTPUT Profile #PF 13

E.G. Elev (ft)	652.71	Element	Left OB	Channel
Right OB Vel Head (ft)	0.44	wt. n-Val.		0.030
W.S. Elev (ft)	652.27	Reach Len. (ft)	114.00	68.00
87.00 Crit w.s. (ft)	651.87	Flow Area (sq ft)		33.02
E.G. Slope (ft/ft)	0.005340	Area (sq ft)		34.66
Q Total (cfs)	175.00	Flow (cfs)		175.00
Top width (ft)	21.73	Top width (ft)		21.73
Vel Total (ft/s)	5.30	Avg. Vel. (ft/s)		5.30
Max Chl Dpth (ft)	2.27	Hydr. Depth (ft)		1.83
Conv. Total (cfs)	2394.7	Conv. (cfs)		2394.7
Length wtd. (ft)	68.00	wetted Per. (ft)		18.64
Min Ch El (ft)	650.00	Shear (lb/sq ft)		0.59
Alpha	1.00	Stream Power (lb/ft s)	41.00	0.00
0.00 Frctn Loss (ft)	0.17	Cum Volume (acre-ft)		0.80
C & E Loss (ft)	0.09	Cum SA (acres)		0.38

Warning: The conveyance ratio (upstream conveyance divided by downstream conveyance) is less than 0.7 or greater than 1.4.

This may indicate the need for additional cross sections.

Note: Multiple critical depths were found at this location. The critical depth with the lowest, valid, energy was used.

CROSS SECTION OUTPUT Profile #PF 14

E.G. Elev (ft)	652.94	Element	Left OB	Channel
Right OB Vel Head (ft)	0.46	wt. n-Val.		0.030
W.S. Elev (ft)	652.47	Reach Len. (ft)	114.00	68.00
87.00 Crit w.s. (ft)	652.00	Flow Area (sq ft)		36.58
E.G. Slope (ft/ft)	0.004958	Area (sq ft)		39.04
Q Total (cfs)	200.00	Flow (cfs)		200.00

		westTribClow.rep	
Top width (ft)	22.62	Top width (ft)	22.62
Vel Total (ft/s)	5.47	Avg. Vel. (ft/s)	5.47
Max Chl Dpth (ft)	2.47	Hydr. Depth (ft)	2.03
Conv. Total (cfs)	2840.3	Conv. (cfs)	2840.3
Length wtd. (ft)	68.00	wetted Per. (ft)	18.64
Min Ch El (ft)	650.00	Shear (lb/sq ft)	0.61
Alpha	1.00	Stream Power (lb/ft s)	41.00
0.00			
Frctn Loss (ft)	0.16	Cum Volume (acre-ft)	0.88
C & E Loss (ft)	0.10	Cum SA (acres)	0.39

Warning: The conveyance ratio (upstream conveyance divided by downstream conveyance) is less than 0.7 or greater than 1.4.

This may indicate the need for additional cross sections.

Note: Multiple critical depths were found at this location. The critical depth with the lowest, valid, energy was used.

CROSS SECTION OUTPUT Profile #PF 15

E.G. Elev (ft)	653.15	Element	Left OB	Channel
Right OB				
Vel Head (ft)	0.49	wt. n-val.		0.030
W.S. Elev (ft)	652.66	Reach Len. (ft)	114.00	68.00
87.00				
Crit W.S. (ft)	652.13	Flow Area (sq ft)		39.93
E.G. Slope (ft/ft)	0.004687	Area (sq ft)		43.33
Q Total (cfs)	225.00	Flow (cfs)		225.00
Top width (ft)	23.46	Top width (ft)		23.46
Vel Total (ft/s)	5.63	Avg. Vel. (ft/s)		5.63
Max Chl Dpth (ft)	2.66	Hydr. Depth (ft)		2.22
Conv. Total (cfs)	3286.4	Conv. (cfs)		3286.4
Length wtd. (ft)	68.00	wetted Per. (ft)		18.64
Min Ch El (ft)	650.00	Shear (lb/sq ft)		0.63
Alpha	1.00	Stream Power (lb/ft s)	41.00	0.00
0.00				
Frctn Loss (ft)	0.16	Cum Volume (acre-ft)		0.95
C & E Loss (ft)	0.10	Cum SA (acres)		0.40

Warning: The conveyance ratio (upstream conveyance divided by downstream conveyance) is less than 0.7 or greater than 1.4.

This may indicate the need for additional cross sections.

Note: Multiple critical depths were found at this location. The critical depth with the lowest, valid, energy was used.

CROSS SECTION OUTPUT Profile #PF 16

E.G. Elev (ft)	653.36	Element	Left OB	Channel
Right OB Vel Head (ft)	0.52	wt. n-Val.		0.030
W.S. Elev (ft)	652.83	Reach Len. (ft)	114.00	68.00
87.00 Crit w.s. (ft)	652.26	Flow Area (sq ft)		43.09
E.G. Slope (ft/ft)	0.004490	Area (sq ft)		47.51
Q Total (cfs)	250.00	Flow (cfs)		250.00
Top width (ft)	24.25	Top width (ft)		24.25
Vel Total (ft/s)	5.80	Avg. Vel. (ft/s)		5.80
Max Chl Dpth (ft)	2.83	Hydr. Depth (ft)		2.39
Conv. Total (cfs)	3730.7	Conv. (cfs)		3730.7
Length wtd. (ft)	68.00	wetted Per. (ft)		18.64
Min Ch El (ft)	650.00	Shear (lb/sq ft)		0.65
Alpha 0.00	1.00	Stream Power (lb/ft s)	41.00	0.00
Frctn Loss (ft)	0.15	Cum Volume (acre-ft)		1.03
C & E Loss (ft)	0.11	Cum SA (acres)		0.41

Warning: The conveyance ratio (upstream conveyance divided by downstream conveyance) is less than 0.7 or greater than 1.4.

This may indicate the need for additional cross sections.

Note: Multiple critical depths were found at this location. The critical depth with the lowest, valid, energy was used.

CROSS SECTION OUTPUT Profile #PF 17

E.G. Elev (ft)	653.55	Element	Left OB	Channel
Right OB Vel Head (ft)	0.55	wt. n-Val.		0.030
W.S. Elev (ft)	653.00	Reach Len. (ft)	114.00	68.00
87.00 Crit w.s. (ft)	652.37	Flow Area (sq ft)		46.08
E.G. Slope (ft/ft)	0.004342	Area (sq ft)		51.61
Q Total (cfs)	275.00	Flow (cfs)		275.00

		westTribClow.rep	
Top width (ft)	25.00	Top width (ft)	25.00
Vel Total (ft/s)	5.97	Avg. Vel. (ft/s)	5.97
Max Chl Dpth (ft)	3.00	Hydr. Depth (ft)	2.56
Conv. Total (cfs)	4173.4	Conv. (cfs)	4173.4
Length wtd. (ft)	68.00	wetted Per. (ft)	18.64
Min Ch El (ft)	650.00	Shear (lb/sq ft)	0.67
Alpha 0.00	1.00	Stream Power (lb/ft s)	41.00
Frctn Loss (ft)	0.15	Cum Volume (acre-ft)	1.10
C & E Loss (ft)	0.11	Cum SA (acres)	0.42

Warning: The conveyance ratio (upstream conveyance divided by downstream conveyance) is less than 0.7 or greater than 1.4.

This may indicate the need for additional cross sections.

Note: Multiple critical depths were found at this location. The critical depth with the lowest, valid, energy was used.

CROSS SECTION OUTPUT Profile #PF 18

E.G. Elev (ft)	653.74	Element	Left OB	Channel
Right OB Vel Head (ft)	0.58	wt. n-val.		0.030
W.S. Elev (ft)	653.16	Reach Len. (ft)	114.00	68.00
87.00 Crit W.S. (ft)	652.49	Flow Area (sq ft)		48.94
E.G. Slope (ft/ft)	0.004229	Area (sq ft)		55.61
Q Total (cfs)	300.00	Flow (cfs)		300.00
Top width (ft)	25.40	Top width (ft)		25.40
Vel Total (ft/s)	6.13	Avg. Vel. (ft/s)		6.13
Max Chl Dpth (ft)	3.16	Hydr. Depth (ft)		2.72
Conv. Total (cfs)	4613.0	Conv. (cfs)		4613.0
Length wtd. (ft)	68.00	wetted Per. (ft)		18.64
Min Ch El (ft)	650.00	Shear (lb/sq ft)		0.69
Alpha 0.00	1.00	Stream Power (lb/ft s)	41.00	0.00
Frctn Loss (ft)	0.15	Cum Volume (acre-ft)		1.17
C & E Loss (ft)	0.12	Cum SA (acres)		0.43

Warning: The conveyance ratio (upstream conveyance divided by downstream conveyance) is less than 0.7 or greater than 1.4.

This may indicate the need for additional cross sections.

Note: Multiple critical depths were found at this location. The critical depth with the lowest, valid, energy was used.

CROSS SECTION OUTPUT Profile #PF 19

E.G. Elev (ft)	653.92	Element	Left OB	Channel
Right OB Vel Head (ft)	0.62	wt. n-Val.		0.030
W.S. Elev (ft)	653.31	Reach Len. (ft)	114.00	68.00
87.00 Crit w.s. (ft)	652.60	Flow Area (sq ft)		51.63
E.G. Slope (ft/ft)	0.004151	Area (sq ft)		59.44
Q Total (cfs)	325.00	Flow (cfs)		325.00
Top width (ft)	25.77	Top width (ft)		25.77
Vel Total (ft/s)	6.29	Avg. Vel. (ft/s)		6.29
Max Chl Dpth (ft)	3.31	Hydr. Depth (ft)		2.87
Conv. Total (cfs)	5044.3	Conv. (cfs)		5044.3
Length wtd. (ft)	68.00	wetted Per. (ft)		18.64
Min Ch El (ft)	650.00	Shear (lb/sq ft)		0.72
Alpha	1.00	Stream Power (lb/ft s)	41.00	0.00
0.00 Frctn Loss (ft)	0.15	Cum Volume (acre-ft)	0.00	1.24
0.00 C & E Loss (ft)	0.13	Cum SA (acres)	0.00	0.44
0.00				

Warning: The conveyance ratio (upstream conveyance divided by downstream conveyance) is less than 0.7 or greater than 1.4.

This may indicate the need for additional cross sections.

Note: Multiple critical depths were found at this location. The critical depth with the lowest, valid, energy was used.

CROSS SECTION OUTPUT Profile #PF 20

E.G. Elev (ft)	654.10	Element	Left OB	Channel
Right OB Vel Head (ft)	0.65	wt. n-Val.		0.030
W.S. Elev (ft)	653.45	Reach Len. (ft)	114.00	68.00
87.00 Crit w.s. (ft)	652.72	Flow Area (sq ft)		54.12
E.G. Slope (ft/ft)	0.004115	Area (sq ft)		63.02
Q Total (cfs)	350.00	Flow (cfs)		350.00

westTribClow.rep				
Top width (ft)	26.12	Top width (ft)		26.12
Vel Total (ft/s)	6.47	Avg. Vel. (ft/s)		6.47
Max Chl Dpth (ft)	3.45	Hydr. Depth (ft)		3.01
Conv. Total (cfs)	5455.9	Conv. (cfs)		5455.9
Length wtd. (ft)	68.00	wetted Per. (ft)		18.64
Min Ch El (ft)	650.00	Shear (lb/sq ft)		0.75
Alpha	1.00	Stream Power (lb/ft s)	41.00	0.00
0.00				
Frctn Loss (ft)	0.15	Cum Volume (acre-ft)	0.00	1.30
0.00				
C & E Loss (ft)	0.13	Cum SA (acres)	0.00	0.45
0.01				

Warning: The conveyance ratio (upstream conveyance divided by downstream conveyance) is less than 0.7 or greater than 1.4.

This may indicate the need for additional cross sections.

Note: Multiple critical depths were found at this location. The critical depth with the lowest, valid, energy was used.

CROSS SECTION OUTPUT Profile #PF 21

E.G. Elev (ft)	654.26	Element	Left OB	Channel
Right OB				
Vel Head (ft)	0.68	wt. n-val.		0.030
W.S. Elev (ft)	653.58	Reach Len. (ft)	114.00	68.00
87.00				
Crit W.S. (ft)	652.82	Flow Area (sq ft)		56.51
E.G. Slope (ft/ft)	0.004092	Area (sq ft)		66.51
Q Total (cfs)	375.00	Flow (cfs)		375.00
Top width (ft)	26.45	Top width (ft)		26.45
Vel Total (ft/s)	6.64	Avg. Vel. (ft/s)		6.64
Max Chl Dpth (ft)	3.58	Hydr. Depth (ft)		3.14
Conv. Total (cfs)	5862.5	Conv. (cfs)		5862.5
Length wtd. (ft)	68.00	wetted Per. (ft)		18.64
Min Ch El (ft)	650.00	Shear (lb/sq ft)		0.77
Alpha	1.00	Stream Power (lb/ft s)	41.00	0.00
0.00				
Frctn Loss (ft)	0.15	Cum Volume (acre-ft)	0.00	1.37
0.00				
C & E Loss (ft)	0.14	Cum SA (acres)	0.00	0.46
0.01				

Warning: The conveyance ratio (upstream conveyance divided by downstream conveyance) is less than 0.7 or greater than 1.4.

This may indicate the need for additional cross sections.

Note: Multiple critical depths were found at this location. The critical depth with the lowest, valid, energy was used.

CROSS SECTION OUTPUT Profile #PF 22

E.G. Elev (ft)	654.43	Element	Left OB	Channel
Right OB				
Vel Head (ft)	0.72	wt. n-Val.		0.030
W.S. Elev (ft)	653.71	Reach Len. (ft)	114.00	68.00
87.00				
Crit w.s. (ft)	652.92	Flow Area (sq ft)		58.88
E.G. Slope (ft/ft)	0.004060	Area (sq ft)		70.01
Q Total (cfs)	400.00	Flow (cfs)		400.00
Top width (ft)	26.78	Top width (ft)		26.78
Vel Total (ft/s)	6.79	Avg. Vel. (ft/s)		6.79
Max Chl Dpth (ft)	3.71	Hydr. Depth (ft)		3.27
Conv. Total (cfs)	6277.8	Conv. (cfs)		6277.8
Length wtd. (ft)	68.00	wetted Per. (ft)		18.64
Min Ch El (ft)	650.00	Shear (lb/sq ft)		0.80
Alpha	1.00	Stream Power (lb/ft s)	41.00	0.00
0.00				
Frctn Loss (ft)	0.15	Cum Volume (acre-ft)	0.00	1.43
0.00				
C & E Loss (ft)	0.15	Cum SA (acres)	0.00	0.46
0.01				

Warning: The velocity head has changed by more than 0.5 ft (0.15 m). This may indicate the need for additional cross sections.

Warning: The conveyance ratio (upstream conveyance divided by downstream conveyance) is less than 0.7 or greater than 1.4.

This may indicate the need for additional cross sections.

Note: Multiple critical depths were found at this location. The critical depth with the lowest, valid, energy was used.

CROSS SECTION OUTPUT Profile #PF 23

E.G. Elev (ft)	654.59	Element	Left OB	Channel
Right OB				
Vel Head (ft)	0.75	wt. n-Val.		0.030
W.S. Elev (ft)	653.84	Reach Len. (ft)	114.00	68.00
87.00				
Crit w.s. (ft)	653.03	Flow Area (sq ft)		61.15
E.G. Slope (ft/ft)	0.004038	Area (sq ft)		73.42

westTribClow.rep				
Q Total (cfs)	425.00	Flow (cfs)		425.00
Top width (ft)	27.09	Top width (ft)		27.09
Vel Total (ft/s)	6.95	Avg. Vel. (ft/s)		6.95
Max Chl Dpth (ft)	3.84	Hydr. Depth (ft)		3.40
Conv. Total (cfs)	6687.9	Conv. (cfs)		6687.9
Length Wtd. (ft)	68.00	wetted Per. (ft)		18.64
Min Ch El (ft)	650.00	Shear (lb/sq ft)		0.83
Alpha 0.00	1.00	Stream Power (lb/ft s)	41.00	0.00
Frctn Loss (ft) 0.01	0.15	Cum volume (acre-ft)	0.00	1.50
C & E Loss (ft) 0.02	0.16	Cum SA (acres)	0.00	0.47

Warning: The velocity head has changed by more than 0.5 ft (0.15 m). This may indicate the need for additional cross sections.
Warning: The conveyance ratio (upstream conveyance divided by downstream conveyance) is less than 0.7 or greater than 1.4.
This may indicate the need for additional cross sections.
Note: Multiple critical depths were found at this location. The critical depth with the lowest, valid, energy was used.

CROSS SECTION OUTPUT Profile #PF 24

E.G. Elev (ft)	654.74	Element	Left OB	Channel
Right OB Vel Head (ft)	0.78	wt. n-val.		0.030
W.S. Elev (ft) 87.00	653.96	Reach Len. (ft)	114.00	68.00
Crit w.s. (ft)	653.12	Flow Area (sq ft)		63.30
E.G. Slope (ft/ft)	0.004036	Area (sq ft)		76.66
Q Total (cfs)	450.00	Flow (cfs)		450.00
Top width (ft)	27.39	Top width (ft)		27.39
Vel Total (ft/s)	7.11	Avg. Vel. (ft/s)		7.11
Max Chl Dpth (ft)	3.96	Hydr. Depth (ft)		3.52
Conv. Total (cfs)	7083.4	Conv. (cfs)		7083.4
Length Wtd. (ft)	68.00	wetted Per. (ft)		18.64
Min Ch El (ft)	650.00	Shear (lb/sq ft)		0.86
Alpha 0.00	1.00	Stream Power (lb/ft s)	41.00	0.00
Frctn Loss (ft) 0.01	0.15	Cum volume (acre-ft)	0.15	1.56
C & E Loss (ft)	0.17	Cum SA (acres)	0.35	0.48

0.02

Warning: The velocity head has changed by more than 0.5 ft (0.15 m). This may indicate the need for additional cross sections.
 Warning: The conveyance ratio (upstream conveyance divided by downstream conveyance) is less than 0.7 or greater than 1.4.
 This may indicate the need for additional cross sections.
 Note: Multiple critical depths were found at this location. The critical depth with the lowest, valid, energy was used.

CROSS SECTION OUTPUT Profile #PF 25

E.G. Elev (ft)	654.87	Element	Left OB	Channel
Right OB				
Vel Head (ft)	0.84	wt. n-Val.		0.030
W.S. Elev (ft)	654.03	Reach Len. (ft)	114.00	68.00
87.00				
Crit w.s. (ft)	653.22	Flow Area (sq ft)		64.65
E.G. Slope (ft/ft)	0.004191	Area (sq ft)		78.73
0.00				
Q Total (cfs)	475.00	Flow (cfs)		475.00
Top width (ft)	27.84	Top width (ft)		27.56
0.28				
Vel Total (ft/s)	7.35	Avg. Vel. (ft/s)		7.35
Max Chl Dpth (ft)	4.03	Hydr. Depth (ft)		3.59
Conv. Total (cfs)	7337.6	Conv. (cfs)		7337.6
Length wtd. (ft)	68.00	wetted Per. (ft)		18.64
Min Ch El (ft)	650.00	Shear (lb/sq ft)		0.91
Alpha	1.00	Stream Power (lb/ft s)	41.00	0.00
0.00				
Frctn Loss (ft)	0.16	Cum Volume (acre-ft)	0.26	1.61
0.03				
C & E Loss (ft)	0.18	Cum SA (acres)	0.58	0.49
0.17				

Warning: The velocity head has changed by more than 0.5 ft (0.15 m). This may indicate the need for additional cross sections.
 Warning: The conveyance ratio (upstream conveyance divided by downstream conveyance) is less than 0.7 or greater than 1.4.
 This may indicate the need for additional cross sections.
 Note: Multiple critical depths were found at this location. The critical depth with the lowest, valid, energy was used.

CROSS SECTION OUTPUT Profile #PF 26

E.G. Elev (ft)	654.99	Element	Left OB	Channel
Right OB				
Vel Head (ft)	0.90	wt. n-Val.		0.030

westTribClow.rep				
W.S. Elev (ft)	654.09	Reach Len. (ft)	114.00	68.00
87.00				
Crit w.s. (ft)	653.32	Flow Area (sq ft)		65.74
E.G. slope (ft/ft)	0.004392	Area (sq ft)		80.40
0.04				
Q Total (cfs)	500.00	Flow (cfs)		500.00
Top width (ft)	28.50	Top width (ft)		27.67
0.82				
Vel Total (ft/s)	7.61	Avg. vel. (ft/s)		7.61
Max chl Dpth (ft)	4.09	Hydr. Depth (ft)		3.65
Conv. Total (cfs)	7544.7	Conv. (cfs)		7544.7
Length wtd. (ft)	68.00	wetted Per. (ft)		18.64
Min ch El (ft)	650.00	Shear (lb/sq ft)		0.97
Alpha	1.00	Stream Power (lb/ft s)	41.00	0.00
0.00				
Frctn Loss (ft)	0.16	Cum volume (acre-ft)	0.35	1.66
0.20				
C & E Loss (ft)	0.19	Cum SA (acres)	0.66	0.49
0.56				

Warning: The velocity head has changed by more than 0.5 ft (0.15 m). This may indicate the need for additional cross sections.
Warning: The conveyance ratio (upstream conveyance divided by downstream conveyance) is less than 0.7 or greater than 1.4.
This may indicate the need for additional cross sections.
Note: Multiple critical depths were found at this location. The critical depth with the lowest, valid, energy was used.

CROSS SECTION OUTPUT Profile #PF 27

		Element	Left OB	Channel
E.G. Elev (ft)	655.11			
Right OB				
Vel Head (ft)	0.96	wt. n-val.		0.030
W.S. Elev (ft)	654.15	Reach Len. (ft)	114.00	68.00
87.00				
Crit w.s. (ft)	653.41	Flow Area (sq ft)		66.81
E.G. slope (ft/ft)	0.004589	Area (sq ft)		82.04
0.10				
Q Total (cfs)	525.00	Flow (cfs)		525.00
Top width (ft)	29.14	Top width (ft)		27.78
1.36				
Vel Total (ft/s)	7.86	Avg. vel. (ft/s)		7.86
Max chl Dpth (ft)	4.15	Hydr. Depth (ft)		3.71
Conv. Total (cfs)	7749.8	Conv. (cfs)		7749.8
Length wtd. (ft)	68.00	wetted Per. (ft)		18.64
Min ch El (ft)	650.00	Shear (lb/sq ft)		1.03

westTribClow.rep

Alpha 0.00	1.00	Stream Power (lb/ft s)	41.00	0.00
Frctn Loss (ft) 0.29	0.17	Cum Volume (acre-ft)	0.74	1.71
C & E Loss (ft) 0.73	0.21	Cum SA (acres)	1.83	0.49

Warning: The velocity head has changed by more than 0.5 ft (0.15 m). This may indicate the need for additional cross sections.
 Warning: The conveyance ratio (upstream conveyance divided by downstream conveyance) is less than 0.7 or greater than 1.4.
 This may indicate the need for additional cross sections.
 Note: Multiple critical depths were found at this location. The critical depth with the lowest, valid, energy was used.

CROSS SECTION OUTPUT Profile #PF 28

E.G. Elev (ft) Right OB	655.19	Element	Left OB	Channel
Vel Head (ft)	1.08	wt. n-Val.		0.030
w.s. Elev (ft) 87.00	654.11	Reach Len. (ft)	114.00	68.00
Crit w.s. (ft)	653.51	Flow Area (sq ft)		66.04
E.G. Slope (ft/ft) 0.05	0.005235	Area (sq ft)		80.86
Q Total (cfs)	550.00	Flow (cfs)		550.00
Top width (ft) 0.97	28.67	Top width (ft)		27.70
Vel Total (ft/s)	8.33	Avg. Vel. (ft/s)		8.33
Max Chl Dpth (ft)	4.11	Hydr. Depth (ft)		3.67
Conv. Total (cfs)	7601.3	Conv. (cfs)		7601.3
Length wtd. (ft)	68.00	wetted Per. (ft)		18.64
Min Ch El (ft)	650.00	Shear (lb/sq ft)		1.16
Alpha 0.00	1.00	Stream Power (lb/ft s)	41.00	0.00
Frctn Loss (ft) 0.68	0.19	Cum Volume (acre-ft)	0.94	1.74
C & E Loss (ft) 1.22	0.23	Cum SA (acres)	2.02	0.49

Warning: The velocity head has changed by more than 0.5 ft (0.15 m). This may indicate the need for additional cross sections.
 Warning: The conveyance ratio (upstream conveyance divided by downstream conveyance) is less than 0.7 or greater than 1.4.
 This may indicate the need for additional cross sections.
 Note: Multiple critical depths were found at this location. The critical depth with the lowest, valid, energy was used.

CROSS SECTION OUTPUT Profile #PF 29

westTribClow.rep

E.G. Elev (ft)	655.30	Element	Left OB	Channel
Right OB				
Vel Head (ft)	1.15	Wt. n-val.		0.030
W.S. Elev (ft)	654.14	Reach Len. (ft)	114.00	68.00
87.00				
Crit w.s. (ft)	653.61	Flow Area (sq ft)		66.67
E.G. slope (ft/ft)	0.005543	Area (sq ft)		81.83
0.09				
Q Total (cfs)	575.00	Flow (cfs)		575.00
Top width (ft)	29.06	Top width (ft)		27.77
1.29				
Vel Total (ft/s)	8.62	Avg. vel. (ft/s)		8.62
Max chl Dpth (ft)	4.14	Hydr. Depth (ft)		3.70
Conv. Total (cfs)	7723.5	Conv. (cfs)		7723.5
Length wtd. (ft)	68.00	wetted Per. (ft)		18.64
Min ch El (ft)	650.00	Shear (lb/sq ft)		1.24
Alpha	1.00	Stream Power (lb/ft s)	41.00	0.00
0.00				
Frctn Loss (ft)	0.20	Cum Volume (acre-ft)	1.10	1.77
0.84				
C & E Loss (ft)	0.25	Cum SA (acres)	2.09	0.50
1.55				

Warning: The velocity head has changed by more than 0.5 ft (0.15 m). This may indicate the need for additional cross sections.
 Warning: The conveyance ratio (upstream conveyance divided by downstream conveyance) is less than 0.7 or greater than 1.4.
 This may indicate the need for additional cross sections.
 Note: Multiple critical depths were found at this location. The critical depth with the lowest, valid, energy was used.

CROSS SECTION OUTPUT Profile #PF 30

E.G. Elev (ft)	655.41	Element	Left OB	Channel
Right OB				
Vel Head (ft)	1.24	Wt. n-val.		0.030
W.S. Elev (ft)	654.17	Reach Len. (ft)	114.00	68.00
87.00				
Crit w.s. (ft)	653.69	Flow Area (sq ft)		67.22
E.G. slope (ft/ft)	0.005871	Area (sq ft)		82.69
0.14				
Q Total (cfs)	600.00	Flow (cfs)		600.00
Top width (ft)	29.39	Top width (ft)		27.83
1.57				
Vel Total (ft/s)	8.93	Avg. vel. (ft/s)		8.93
Max chl Dpth (ft)	4.17	Hydr. Depth (ft)		3.73

WestTribClow.rep

Conv. Total (cfs)	7830.3	Conv. (cfs)	7830.3
Length wtd. (ft)	68.00	wetted Per. (ft)	18.64
Min Ch El (ft)	650.00	Shear (lb/sq ft)	1.32
Alpha	1.00	Stream Power (lb/ft s)	41.00
0.00		Cum Volume (acre-ft)	1.28
Frctn Loss (ft)	0.21	Cum SA (acres)	2.16
0.95			
C & E Loss (ft)	0.27		
1.64			

Warning: The velocity head has changed by more than 0.5 ft (0.15 m). This may indicate the need for additional cross sections.
 Warning: The conveyance ratio (upstream conveyance divided by downstream conveyance) is less than 0.7 or greater than 1.4.
 This may indicate the need for additional cross sections.
 Note: Multiple critical depths were found at this location. The critical depth with the lowest, valid, energy was used.

CROSS SECTION

RIVER: WestTribClow
 REACH: WestTribClow RS: 1709

INPUT

Description: Sta 17+09
 Station Elevation Data

num=		25							
Sta	Elev	Sta	Elev	Sta	Elev	Sta	Elev	Sta	Elev
-127.5	655.1	-124	655	-39	654.1	-10	654.9	-6	654
-5.5	653	-5	652	-4.5	651	-4	650	0	649.1
1.5	650	8.5	650.5	10.5	650	14	649.3	17	650
19.5	651	22	652	24	653	27	654	30	655
31	655.1	32	655	60	654.3	101	654.6	140.5	654.7

Manning's n Values		num=		3	
Sta	n Val	Sta	n Val	Sta	n Val
-127.5	.08	-10	.03	31	.08

Bank Sta: Left	Right	Lengths: Left	Channel	Right	Coeff	Contr.	Expan.
-10	31	76	82	60	.1	.3	

Ineffective Flow num= 2
 Station Elevation Data

Sta L	Sta R	Elev	Permanent
-127.5	-10	658.1	F
34	140.5	658.1	F
Left Levee	Station=	-10	Elevation= 655
Right Levee	Station=	31	Elevation= 654.5

CROSS SECTION OUTPUT Profile #PF 1

E.G. Elev (ft)	650.07	Element	Left OB	Channel
Right OB				
Vel Head (ft)	0.07	wt. n-Val.		0.030
w.s. Elev (ft)	650.01	Reach Len. (ft)	76.00	82.00
60.00				
Crit w.s. (ft)	649.85	Flow Area (sq ft)		4.81

westTribFlow.rep

E.G. Slope (ft/ft)	0.006357	Area (sq ft)		4.81
Q Total (cfs)	10.00	Flow (cfs)		10.00
Top width (ft)	12.11	Top width (ft)		12.11
Vel Total (ft/s)	2.08	Avg. Vel. (ft/s)		2.08
Max Chl Dpth (ft)	0.91	Hydr. Depth (ft)		0.40
Conv. Total (cfs)	125.4	Conv. (cfs)		125.4
Length Wtd. (ft)	82.00	wetted Per. (ft)		12.61
Min Ch El (ft)	649.10	Shear (lb/sq ft)		0.15
Alpha	1.00	Stream Power (lb/ft s)	140.50	-10.00
31.00				
Frctn Loss (ft)	0.29	Cum Volume (acre-ft)		0.09
C & E Loss (ft)	0.01	Cum SA (acres)		0.17

Warning: Divided flow computed for this cross-section.
 Warning: The conveyance ratio (upstream conveyance divided by downstream conveyance) is less than 0.7 or greater than 1.4.

This may indicate the need for additional cross sections.

Note: Multiple critical depths were found at this location. The critical depth with the lowest, valid, energy was used.

CROSS SECTION OUTPUT Profile #PF 2

E.G. Elev (ft)	650.37	Element	Left OB	Channel
Right OB				
Vel Head (ft)	0.07	wt. n-val.		0.030
W.S. Elev (ft)	650.29	Reach Len. (ft)	76.00	82.00
60.00				
Crit W.S. (ft)	650.06	Flow Area (sq ft)		9.17
E.G. Slope (ft/ft)	0.005103	Area (sq ft)		9.17
Q Total (cfs)	20.00	Flow (cfs)		20.00
Top Width (ft)	18.15	Top Width (ft)		18.15
Vel Total (ft/s)	2.18	Avg. Vel. (ft/s)		2.18
Max Chl Dpth (ft)	1.19	Hydr. Depth (ft)		0.51
Conv. Total (cfs)	280.0	Conv. (cfs)		280.0
Length Wtd. (ft)	82.00	wetted Per. (ft)		18.94
Min Ch El (ft)	649.10	Shear (lb/sq ft)		0.15
Alpha	1.00	Stream Power (lb/ft s)	140.50	-10.00
31.00				
Frctn Loss (ft)	0.26	Cum Volume (acre-ft)		0.16

WestTribClow.rep

C & E Loss (ft) 0.01 Cum SA (acres) 0.21

Warning: Divided flow computed for this cross-section.
 Warning: The conveyance ratio (upstream conveyance divided by downstream conveyance) is less than 0.7 or greater than 1.4.

This may indicate the need for additional cross sections.

Note: Multiple critical depths were found at this location. The critical depth with the lowest, valid, energy was used.

CROSS SECTION OUTPUT Profile #PF 3

E.G. Elev (ft)	650.59	Element	Left OB	Channel
Right OB				
Vel Head (ft)	0.08	wt. n-val.		0.030
w.s. Elev (ft)	650.51	Reach Len. (ft)	76.00	82.00
60.00				
Crit w.s. (ft)	650.20	Flow Area (sq ft)		13.60
E.G. slope (ft/ft)	0.004120	Area (sq ft)		13.60
Q Total (cfs)	30.00	Flow (cfs)		30.00
Top width (ft)	22.53	Top width (ft)		22.53
Vel Total (ft/s)	2.21	Avg. vel. (ft/s)		2.21
Max chl Dpth (ft)	1.41	Hydr. Depth (ft)		0.60
Conv. Total (cfs)	467.4	Conv. (cfs)		467.4
Length wtd. (ft)	82.00	wetted Per. (ft)		23.52
Min ch El (ft)	649.10	Shear (lb/sq ft)		0.15
Alpha	1.00	Stream Power (lb/ft s)	140.50	-10.00
31.00				
Frctn Loss (ft)	0.22	Cum volume (acre-ft)		0.21
C & E Loss (ft)	0.01	Cum SA (acres)		0.23

Warning: The conveyance ratio (upstream conveyance divided by downstream conveyance) is less than 0.7 or greater than 1.4.

This may indicate the need for additional cross sections.

Note: Multiple critical depths were found at this location. The critical depth with the lowest, valid, energy was used.

CROSS SECTION OUTPUT Profile #PF 4

E.G. Elev (ft)	650.77	Element	Left OB	Channel
Right OB				
Vel Head (ft)	0.08	wt. n-val.		0.030
w.s. Elev (ft)	650.69	Reach Len. (ft)	76.00	82.00

westTribClow.rep

60.00				
Crit w.s. (ft)	650.32	Flow Area (sq ft)		17.68
E.G. Slope (ft/ft)	0.003169	Area (sq ft)		17.68
Q Total (cfs)	40.00	Flow (cfs)		40.00
Top Width (ft)	23.07	Top Width (ft)		23.07
Vel Total (ft/s)	2.26	Avg. Vel. (ft/s)		2.26
Max Chl Dpth (ft)	1.59	Hydr. Depth (ft)		0.77
Conv. Total (cfs)	710.6	Conv. (cfs)		710.6
Length Wtd. (ft)	82.00	wetted Per. (ft)		24.20
Min Ch El (ft)	649.10	Shear (lb/sq ft)		0.14
Alpha	1.00	Stream Power (lb/ft s)	140.50	-10.00
31.00				
Frctn Loss (ft)	0.19	Cum volume (acre-ft)		0.26
C & E Loss (ft)	0.00	Cum SA (acres)		0.25

Note: Multiple critical depths were found at this location. The critical depth with the lowest, valid, energy was used.

CROSS SECTION OUTPUT Profile #PF 5

E.G. Elev (ft)	650.94	Element	Left OB	Channel
Right OB				
Vel Head (ft)	0.08	wt. n-val.		0.030
W.S. Elev (ft)	650.86	Reach Len. (ft)	76.00	82.00
60.00				
Crit w.s. (ft)	650.43	Flow Area (sq ft)		21.61
E.G. Slope (ft/ft)	0.002629	Area (sq ft)		21.61
Q Total (cfs)	50.00	Flow (cfs)		50.00
Top Width (ft)	23.57	Top Width (ft)		23.57
Vel Total (ft/s)	2.31	Avg. Vel. (ft/s)		2.31
Max Chl Dpth (ft)	1.76	Hydr. Depth (ft)		0.92
Conv. Total (cfs)	975.1	Conv. (cfs)		975.1
Length Wtd. (ft)	82.00	wetted Per. (ft)		24.85
Min Ch El (ft)	649.10	Shear (lb/sq ft)		0.14
Alpha	1.00	Stream Power (lb/ft s)	140.50	-10.00
31.00				
Frctn Loss (ft)	0.17	Cum volume (acre-ft)		0.31
C & E Loss (ft)	0.00	Cum SA (acres)		0.26

WestTribClow.rep

Note: Multiple critical depths were found at this location. The critical depth with the lowest, valid, energy was used.

CROSS SECTION OUTPUT Profile #PF 6

E.G. Elev (ft)	651.10	Element	Left OB	Channel
Right OB Vel Head (ft)	0.09	wt. n-val.		0.030
W.S. Elev (ft)	651.02	Reach Len. (ft)	76.00	82.00
60.00 Crit w.s. (ft)	650.51	Flow Area (sq ft)		25.37
E.G. slope (ft/ft)	0.002288	Area (sq ft)		25.37
Q Total (cfs)	60.00	Flow (cfs)		60.00
Top width (ft)	24.05	Top width (ft)		24.05
Vel Total (ft/s)	2.36	Avg. vel. (ft/s)		2.36
Max Chl Dpth (ft)	1.92	Hydr. Depth (ft)		1.06
Conv. Total (cfs)	1254.3	Conv. (cfs)		1254.3
Length wtd. (ft)	82.00	wetted Per. (ft)		25.45
Min Ch El (ft)	649.10	Shear (lb/sq ft)		0.14
Alpha	1.00	Stream Power (lb/ft s)	140.50	-10.00
31.00 Frctn Loss (ft)	0.16	Cum volume (acre-ft)		0.35
C & E Loss (ft)	0.00	Cum SA (acres)		0.27

Note: Multiple critical depths were found at this location. The critical depth with the lowest, valid, energy was used.

CROSS SECTION OUTPUT Profile #PF 7

E.G. Elev (ft)	651.25	Element	Left OB	Channel
Right OB Vel Head (ft)	0.09	wt. n-val.		0.030
W.S. Elev (ft)	651.16	Reach Len. (ft)	76.00	82.00
60.00 Crit w.s. (ft)	650.57	Flow Area (sq ft)		28.90
E.G. slope (ft/ft)	0.002078	Area (sq ft)		28.90
Q Total (cfs)	70.00	Flow (cfs)		70.00
Top width (ft)	24.48	Top width (ft)		24.48

westTribClow.rep			
Vel Total (ft/s)	2.42	Avg. Vel. (ft/s)	2.42
Max Chl Dpth (ft)	2.06	Hydr. Depth (ft)	1.18
Conv. Total (cfs)	1535.6	Conv. (cfs)	1535.6
Length wtd. (ft)	82.00	wetted Per. (ft)	26.00
Min Ch El (ft)	649.10	Shear (lb/sq ft)	0.14
Alpha 31.00	1.00	Stream Power (lb/ft s)	140.50 -10.00
Frctn Loss (ft)	0.15	Cum Volume (acre-ft)	0.39
C & E Loss (ft)	0.00	Cum SA (acres)	0.28

Note: Multiple critical depths were found at this location. The critical depth with the lowest, valid, energy was used.

CROSS SECTION OUTPUT Profile #PF 8

E.G. Elev (ft)	651.39	Element	Left OB	Channel
Right OB Vel Head (ft)	0.10	wt. n-val.		0.030
W.S. Elev (ft)	651.29	Reach Len. (ft)	76.00	82.00
60.00 Crit w.s. (ft)	650.64	Flow Area (sq ft)		32.19
E.G. slope (ft/ft)	0.001944	Area (sq ft)		32.19
Q Total (cfs)	80.00	Flow (cfs)		80.00
Top width (ft)	24.88	Top width (ft)		24.88
Vel Total (ft/s)	2.49	Avg. Vel. (ft/s)		2.49
Max Chl Dpth (ft)	2.19	Hydr. Depth (ft)		1.29
Conv. Total (cfs)	1814.5	Conv. (cfs)		1814.5
Length wtd. (ft)	82.00	wetted Per. (ft)		26.51
Min Ch El (ft)	649.10	Shear (lb/sq ft)		0.15
Alpha 31.00	1.00	Stream Power (lb/ft s)	140.50	-10.00
Frctn Loss (ft)	0.14	Cum Volume (acre-ft)		0.42
C & E Loss (ft)	0.00	Cum SA (acres)		0.29

Note: Multiple critical depths were found at this location. The critical depth with the lowest, valid, energy was used.

CROSS SECTION OUTPUT Profile #PF 9

WestTribClow.rep

E.G. Elev (ft)	651.52	Element	Left OB	Channel
Right OB Vel Head (ft)	0.10	wt. n-val.		0.030
W.S. Elev (ft)	651.42	Reach Len. (ft)	76.00	82.00
60.00 Crit w.s. (ft)	650.70	Flow Area (sq ft)		35.37
E.G. slope (ft/ft)	0.001841	Area (sq ft)		35.37
Q Total (cfs)	90.00	Flow (cfs)		90.00
Top width (ft)	25.26	Top width (ft)		25.26
Vel Total (ft/s)	2.54	Avg. vel. (ft/s)		2.54
Max Chl Dpth (ft)	2.32	Hydr. Depth (ft)		1.40
Conv. Total (cfs)	2097.5	Conv. (cfs)		2097.5
Length wtd. (ft)	82.00	wetted Per. (ft)		26.99
Min Ch El (ft)	649.10	Shear (lb/sq ft)		0.15
Alpha	1.00	Stream Power (lb/ft s)	140.50	-10.00
31.00 Frctn Loss (ft)	0.14	Cum volume (acre-ft)		0.46
C & E Loss (ft)	0.00	Cum SA (acres)		0.30

Note: Multiple critical depths were found at this location. The critical depth with the lowest, valid, energy was used.

CROSS SECTION OUTPUT Profile #PF 10

E.G. Elev (ft)	651.65	Element	Left OB	Channel
Right OB Vel Head (ft)	0.11	wt. n-val.		0.030
W.S. Elev (ft)	651.54	Reach Len. (ft)	76.00	82.00
60.00 Crit w.s. (ft)	650.76	Flow Area (sq ft)		38.44
E.G. slope (ft/ft)	0.001761	Area (sq ft)		38.44
Q Total (cfs)	100.00	Flow (cfs)		100.00
Top width (ft)	25.63	Top width (ft)		25.63
Vel Total (ft/s)	2.60	Avg. vel. (ft/s)		2.60
Max Chl Dpth (ft)	2.44	Hydr. Depth (ft)		1.50
Conv. Total (cfs)	2383.2	Conv. (cfs)		2383.2
Length wtd. (ft)	82.00	wetted Per. (ft)		27.45
Min Ch El (ft)	649.10	Shear (lb/sq ft)		0.15

westTribClow.rep

Alpha	1.00	Stream Power (lb/ft s)	140.50	-10.00
31.00				
Frctn Loss (ft)	0.13	Cum Volume (acre-ft)		0.49
C & E Loss (ft)	0.00	Cum SA (acres)		0.30

Note: Multiple critical depths were found at this location. The critical depth with the lowest, valid, energy was used.

CROSS SECTION OUTPUT Profile #PF 11

E.G. Elev (ft)	651.94	Element	Left OB	Channel
Right OB				
Vel Head (ft)	0.12	wt. n-val.		0.030
W.S. Elev (ft)	651.82	Reach Len. (ft)	76.00	82.00
60.00				
Crit w.s. (ft)	650.90	Flow Area (sq ft)		45.72
E.G. slope (ft/ft)	0.001623	Area (sq ft)		45.72
Q Total (cfs)	125.00	Flow (cfs)		125.00
Top width (ft)	26.46	Top width (ft)		26.46
Vel Total (ft/s)	2.73	Avg. vel. (ft/s)		2.73
Max chl Dpth (ft)	2.72	Hydr. Depth (ft)		1.73
Conv. Total (cfs)	3102.4	Conv. (cfs)		3102.4
Length wtd. (ft)	82.00	wetted Per. (ft)		28.52
Min ch El (ft)	649.10	Shear (lb/sq ft)		0.16
Alpha	1.00	Stream Power (lb/ft s)	140.50	-10.00
31.00				
Frctn Loss (ft)	0.12	Cum volume (acre-ft)		0.57
C & E Loss (ft)	0.00	Cum SA (acres)		0.32

Note: Multiple critical depths were found at this location. The critical depth with the lowest, valid, energy was used.

CROSS SECTION OUTPUT Profile #PF 12

E.G. Elev (ft)	652.20	Element	Left OB	Channel
Right OB				
Vel Head (ft)	0.13	wt. n-val.		0.030
W.S. Elev (ft)	652.08	Reach Len. (ft)	76.00	82.00
60.00				
Crit w.s. (ft)	651.03	Flow Area (sq ft)		52.56

westTribClow.rep			
E.G. Slope (ft/ft)	0.001534	Area (sq ft)	52.56
Q Total (cfs)	150.00	Flow (cfs)	150.00
Top Width (ft)	27.19	Top Width (ft)	27.19
Vel Total (ft/s)	2.85	Avg. Vel. (ft/s)	2.85
Max Chl Dpth (ft)	2.98	Hydr. Depth (ft)	1.93
Conv. Total (cfs)	3829.7	Conv. (cfs)	3829.7
Length Wtd. (ft)	82.00	wetted Per. (ft)	29.45
Min Ch El (ft)	649.10	Shear (lb/sq ft)	0.17
Alpha	1.00	Stream Power (lb/ft s)	140.50
31.00			-10.00
Frctn Loss (ft)	0.12	Cum Volume (acre-ft)	0.65
C & E Loss (ft)	0.00	Cum SA (acres)	0.33

Note: Multiple critical depths were found at this location. The critical depth with the lowest, valid, energy was used.

CROSS SECTION OUTPUT Profile #PF 13

E.G. Elev (ft)	652.45	Element	Left OB	Channel
Right OB				
Vel Head (ft)	0.14	wt. n-val.		0.030
W.S. Elev (ft)	652.31	Reach Len. (ft)	76.00	82.00
60.00				
Crit W.S. (ft)	651.15	Flow Area (sq ft)		59.01
E.G. Slope (ft/ft)	0.001470	Area (sq ft)		59.01
Q Total (cfs)	175.00	Flow (cfs)		175.00
Top Width (ft)	27.78	Top Width (ft)		27.78
Vel Total (ft/s)	2.97	Avg. Vel. (ft/s)		2.97
Max Chl Dpth (ft)	3.21	Hydr. Depth (ft)		2.12
Conv. Total (cfs)	4564.0	Conv. (cfs)		4564.0
Length Wtd. (ft)	82.00	wetted Per. (ft)		30.24
Min Ch El (ft)	649.10	Shear (lb/sq ft)		0.18
Alpha	1.00	Stream Power (lb/ft s)	140.50	-10.00
31.00				
Frctn Loss (ft)	0.12	Cum Volume (acre-ft)		0.72
C & E Loss (ft)	0.00	Cum SA (acres)		0.34

WestTribClow.rep

Note: Multiple critical depths were found at this location. The critical depth with the lowest, valid, energy was used.

CROSS SECTION OUTPUT Profile #PF 14

E.G. Elev (ft)	652.68	Element	Left OB	Channel
Right OB Vel Head (ft)	0.15	wt. n-val.		0.030
W.S. Elev (ft)	652.53	Reach Len. (ft)	76.00	82.00
60.00 Crit w.s. (ft)	651.27	Flow Area (sq ft)		65.13
E.G. slope (ft/ft)	0.001427	Area (sq ft)		65.13
Q Total (cfs)	200.00	Flow (cfs)		200.00
Top width (ft)	28.32	Top width (ft)		28.32
Vel Total (ft/s)	3.07	Avg. vel. (ft/s)		3.07
Max Chl Dpth (ft)	3.43	Hydr. Depth (ft)		2.30
Conv. Total (cfs)	5295.1	Conv. (cfs)		5295.1
Length wtd. (ft)	82.00	wetted Per. (ft)		30.97
Min Ch El (ft)	649.10	Shear (lb/sq ft)		0.19
Alpha	1.00	Stream Power (lb/ft s)	140.50	-10.00
31.00 Frctn Loss (ft)	0.11	Cum volume (acre-ft)		0.79
C & E Loss (ft)	0.00	Cum SA (acres)		0.35

Note: Multiple critical depths were found at this location. The critical depth with the lowest, valid, energy was used.

CROSS SECTION OUTPUT Profile #PF 15

E.G. Elev (ft)	652.89	Element	Left OB	Channel
Right OB Vel Head (ft)	0.16	wt. n-val.		0.030
W.S. Elev (ft)	652.73	Reach Len. (ft)	76.00	82.00
60.00 Crit w.s. (ft)	651.36	Flow Area (sq ft)		70.99
E.G. slope (ft/ft)	0.001395	Area (sq ft)		70.99
Q Total (cfs)	225.00	Flow (cfs)		225.00
Top width (ft)	28.84	Top width (ft)		28.84
Vel Total (ft/s)	3.17	Avg. vel. (ft/s)		3.17
Max Chl Dpth (ft)	3.63	Hydr. Depth (ft)		2.46

westTribClow.rep

Conv. Total (cfs)	6023.7	Conv. (cfs)	6023.7
Length wtd. (ft)	82.00	wetted Per. (ft)	31.66
Min Ch El (ft)	649.10	Shear (lb/sq ft)	0.20
Alpha 31.00	1.00	Stream Power (lb/ft s)	140.50
Frctn Loss (ft)	0.11	Cum Volume (acre-ft)	0.86
C & E Loss (ft)	0.00	Cum SA (acres)	0.36

Note: Multiple critical depths were found at this location. The critical depth with the lowest, valid, energy was used.

CROSS SECTION OUTPUT Profile #PF 16

E.G. Elev (ft)	653.09	Element	Left OB	Channel
Right OB Vel Head (ft)	0.17	wt. n-val.		0.030
w.s. Elev (ft)	652.93	Reach Len. (ft)	76.00	82.00
60.00 Crit w.s. (ft)	651.48	Flow Area (sq ft)		76.63
E.G. slope (ft/ft)	0.001372	Area (sq ft)		76.63
Q Total (cfs)	250.00	Flow (cfs)		250.00
Top width (ft)	29.32	Top width (ft)		29.32
vel Total (ft/s)	3.26	Avg. vel. (ft/s)		3.26
Max Chl Dpth (ft)	3.83	Hydr. Depth (ft)		2.61
Conv. Total (cfs)	6749.6	Conv. (cfs)		6749.6
Length wtd. (ft)	82.00	wetted Per. (ft)		32.31
Min Ch El (ft)	649.10	Shear (lb/sq ft)		0.20
Alpha 31.00	1.00	Stream Power (lb/ft s)	140.50	-10.00
Frctn Loss (ft)	0.11	Cum Volume (acre-ft)		0.93
C & E Loss (ft)	0.00	Cum SA (acres)		0.37

Note: Multiple critical depths were found at this location. The critical depth with the lowest, valid, energy was used.

CROSS SECTION OUTPUT Profile #PF 17

E.G. Elev (ft)	653.29	Element	Left OB	Channel
Right OB				

westTribClow.rep				
Vel Head (ft)	0.17	wt. n-val.		0.030
W.S. Elev (ft)	653.11	Reach Len. (ft)	76.00	82.00
60.00				
Crit W.S. (ft)	651.57	Flow Area (sq ft)		82.07
E.G. Slope (ft/ft)	0.001360	Area (sq ft)		82.07
Q Total (cfs)	275.00	Flow (cfs)		275.00
Top width (ft)	29.89	Top width (ft)		29.89
Vel Total (ft/s)	3.35	Avg. vel. (ft/s)		3.35
Max Chl Dpth (ft)	4.01	Hydr. Depth (ft)		2.75
Conv. Total (cfs)	7457.4	Conv. (cfs)		7457.4
Length wtd. (ft)	82.00	wetted Per. (ft)		33.03
Min Ch El (ft)	649.10	Shear (lb/sq ft)		0.21
Alpha	1.00	Stream Power (lb/ft s)	140.50	-10.00
31.00				
Frctn Loss (ft)	0.11	Cum volume (acre-ft)		0.99
C & E Loss (ft)	0.00	Cum SA (acres)		0.38

Note: Multiple critical depths were found at this location. The critical depth with the lowest, valid, energy was used.

CROSS SECTION OUTPUT Profile #PF 18

E.G. Elev (ft)	653.47	Element	Left OB	Channel
Right OB				
Vel Head (ft)	0.18	wt. n-val.		0.030
W.S. Elev (ft)	653.29	Reach Len. (ft)	76.00	82.00
60.00				
Crit W.S. (ft)	651.67	Flow Area (sq ft)		87.39
E.G. Slope (ft/ft)	0.001353	Area (sq ft)		87.39
Q Total (cfs)	300.00	Flow (cfs)		300.00
Top width (ft)	30.51	Top width (ft)		30.51
Vel Total (ft/s)	3.43	Avg. vel. (ft/s)		3.43
Max Chl Dpth (ft)	4.19	Hydr. Depth (ft)		2.86
Conv. Total (cfs)	8155.6	Conv. (cfs)		8155.6
Length wtd. (ft)	82.00	wetted Per. (ft)		33.79
Min Ch El (ft)	649.10	Shear (lb/sq ft)		0.22
Alpha	1.00	Stream Power (lb/ft s)	140.50	-10.00
31.00				

Frctn Loss (ft)	0.11	westTribCflow.rep Cum Volume (acre-ft)	1.06
C & E Loss (ft)	0.00	Cum SA (acres)	0.39

Note: Multiple critical depths were found at this location. The critical depth with the lowest, valid, energy was used.

CROSS SECTION OUTPUT Profile #PF 19

E.G. Elev (ft)	653.65	Element	Left OB	Channel
Right OB Vel Head (ft)	0.19	wt. n-val.		0.030
W.S. Elev (ft)	653.46	Reach Len. (ft)	76.00	82.00
60.00 Crit w.s. (ft)	651.76	Flow Area (sq ft)		92.54
E.G. slope (ft/ft)	0.001349	Area (sq ft)		92.54
Q Total (cfs)	325.00	Flow (cfs)		325.00
Top width (ft)	31.09	Top width (ft)		31.09
Vel Total (ft/s)	3.51	Avg. vel. (ft/s)		3.51
Max Chl Dpth (ft)	4.36	Hydr. Depth (ft)		2.98
Conv. Total (cfs)	8847.7	Conv. (cfs)		8847.7
Length wtd. (ft)	82.00	wetted Per. (ft)		34.50
Min Ch El (ft)	649.10	Shear (lb/sq ft)		0.23
Alpha 31.00	1.00	Stream Power (lb/ft s)	140.50	-10.00
Frctn Loss (ft)	0.11	Cum volume (acre-ft)	0.00	1.12
0.00 C & E Loss (ft)	0.00	Cum SA (acres)	0.00	0.40
0.00				

Note: Multiple critical depths were found at this location. The critical depth with the lowest, valid, energy was used.

CROSS SECTION OUTPUT Profile #PF 20

E.G. Elev (ft)	653.81	Element	Left OB	Channel
Right OB Vel Head (ft)	0.20	wt. n-val.		0.030
W.S. Elev (ft)	653.61	Reach Len. (ft)	76.00	82.00
60.00 Crit w.s. (ft)	651.85	Flow Area (sq ft)		97.44
E.G. slope (ft/ft)	0.001352	Area (sq ft)		97.44
Q Total (cfs)	350.00	Flow (cfs)		350.00

westTribClow.rep

Top Width (ft)	31.64	Top Width (ft)	31.64
Vel Total (ft/s)	3.59	Avg. Vel. (ft/s)	3.59
Max Chl Dpth (ft)	4.51	Hydr. Depth (ft)	3.08
Conv. Total (cfs)	9520.3	Conv. (cfs)	9520.3
Length Wtd. (ft)	82.00	wetted Per. (ft)	35.17
Min Ch El (ft)	649.10	Shear (lb/sq ft)	0.23
Alpha	1.00	Stream Power (lb/ft s)	140.50
31.00			-10.00
Frctn Loss (ft)	0.11	Cum Volume (acre-ft)	0.00
0.00			1.18
C & E Loss (ft)	0.00	Cum SA (acres)	0.00
0.01			0.40

Note: Multiple critical depths were found at this location. The critical depth with the lowest, valid, energy was used.

CROSS SECTION OUTPUT Profile #PF 21

E.G. Elev (ft)	653.97	Element	Left OB	Channel
Right OB				
Vel Head (ft)	0.21	wt. n-val.		0.030
W.S. Elev (ft)	653.76	Reach Len. (ft)	76.00	82.00
60.00				
Crit w.s. (ft)	651.94	Flow Area (sq ft)		102.25
E.G. slope (ft/ft)	0.001354	Area (sq ft)		102.25
Q Total (cfs)	375.00	Flow (cfs)		375.00
Top width (ft)	32.17	Top width (ft)		32.17
Vel Total (ft/s)	3.67	Avg. Vel. (ft/s)		3.67
Max Chl Dpth (ft)	4.66	Hydr. Depth (ft)		3.18
Conv. Total (cfs)	10192.3	Conv. (cfs)		10192.3
Length Wtd. (ft)	82.00	wetted Per. (ft)		35.82
Min Ch El (ft)	649.10	Shear (lb/sq ft)		0.24
Alpha	1.00	Stream Power (lb/ft s)	140.50	-10.00
31.00				
Frctn Loss (ft)	0.11	Cum Volume (acre-ft)	0.00	1.24
0.00				
C & E Loss (ft)	0.00	Cum SA (acres)	0.00	0.41
0.01				

Note: Multiple critical depths were found at this location. The critical depth with the lowest, valid, energy was used.

WestTribClow.rep

CROSS SECTION OUTPUT Profile #PF 22

E.G. Elev (ft)	654.13	Element	Left OB	Channel
Right OB Vel Head (ft)	0.22	wt. n-val.		0.030
W.S. Elev (ft)	653.91	Reach Len. (ft)	76.00	82.00
60.00 Crit W.S. (ft)	652.02	Flow Area (sq ft)		107.11
E.G. slope (ft/ft)	0.001351	Area (sq ft)		107.11
Q Total (cfs)	400.00	Flow (cfs)		400.00
Top width (ft)	32.69	Top width (ft)		32.69
Vel Total (ft/s)	3.73	Avg. vel. (ft/s)		3.73
Max Chl Dpth (ft)	4.81	Hydr. Depth (ft)		3.28
Conv. Total (cfs)	10882.5	Conv. (cfs)		10882.5
Length wtd. (ft)	82.00	wetted Per. (ft)		36.46
Min Ch El (ft)	649.10	Shear (lb/sq ft)		0.25
Alpha	1.00	Stream Power (lb/ft s)	140.50	-10.00
31.00 Frctn Loss (ft)	0.11	Cum volume (acre-ft)	0.00	1.30
0.00 C & E Loss (ft)	0.00	Cum SA (acres)	0.00	0.42
0.01				

Note: Multiple critical depths were found at this location. The critical depth with the lowest, valid, energy was used.

CROSS SECTION OUTPUT Profile #PF 23

E.G. Elev (ft)	654.28	Element	Left OB	Channel
Right OB Vel Head (ft)	0.22	wt. n-val.		0.030
W.S. Elev (ft)	654.06	Reach Len. (ft)	76.00	82.00
60.00 Crit W.S. (ft)	652.11	Flow Area (sq ft)		111.87
E.G. slope (ft/ft)	0.001359	Area (sq ft)		111.87
Q Total (cfs)	425.00	Flow (cfs)		425.00
Top width (ft)	33.42	Top width (ft)		33.42
Vel Total (ft/s)	3.80	Avg. vel. (ft/s)		3.80
Max Chl Dpth (ft)	4.96	Hydr. Depth (ft)		3.35
Conv. Total (cfs)	11530.0	Conv. (cfs)		11530.0

westTribClow.rep				
Length wtd. (ft)	82.00	Wetted Per. (ft)		37.27
Min Ch El (ft)	649.10	Shear (lb/sq ft)		0.25
Alpha	1.00	Stream Power (lb/ft s)	140.50	-10.00
31.00				
Frctn Loss (ft)	0.11	Cum Volume (acre-ft)	0.00	1.35
0.01				
C & E Loss (ft)	0.00	Cum SA (acres)	0.00	0.43
0.02				

Note: Multiple critical depths were found at this location. The critical depth with the lowest, valid, energy was used.

CROSS SECTION OUTPUT Profile #PF 24

E.G. Elev (ft)	654.42	Element	Left OB	Channel
Right OB				
Vel Head (ft)	0.23	wt. n-val.		0.030
W.S. Elev (ft)	654.19	Reach Len. (ft)	76.00	82.00
60.00				
Crit w.s. (ft)	652.20	Flow Area (sq ft)		116.51
E.G. slope (ft/ft)	0.001381	Area (sq ft)		116.51
Q Total (cfs)	450.00	Flow (cfs)		450.00
Top width (ft)	34.44	Top width (ft)		34.44
Vel Total (ft/s)	3.86	Avg. vel. (ft/s)		3.86
Max Chl Dpth (ft)	5.09	Hydr. Depth (ft)		3.38
Conv. Total (cfs)	12110.5	Conv. (cfs)		12110.5
Length wtd. (ft)	82.00	Wetted Per. (ft)		38.32
Min Ch El (ft)	649.10	Shear (lb/sq ft)		0.26
Alpha	1.00	Stream Power (lb/ft s)	140.50	-10.00
31.00				
Frctn Loss (ft)	0.11	Cum Volume (acre-ft)	0.15	1.41
0.01				
C & E Loss (ft)	0.00	Cum SA (acres)	0.35	0.43
0.02				

Note: Multiple critical depths were found at this location. The critical depth with the lowest, valid, energy was used.

CROSS SECTION OUTPUT Profile #PF 25

E.G. Elev (ft)	654.54	Element	Left OB	Channel
Right OB				
Vel Head (ft)	0.24	wt. n-val.		0.030
W.S. Elev (ft)	654.29	Reach Len. (ft)	76.00	82.00

westTribClow.rep

60.00				
Crit w.s. (ft)	652.27	Flow Area (sq ft)		119.93
E.G. Slope (ft/ft)	0.001434	Area (sq ft)		119.93
Q Total (cfs)	475.00	Flow (cfs)		475.00
Top width (ft)	35.17	Top width (ft)		35.17
Vel Total (ft/s)	3.96	Avg. vel. (ft/s)		3.96
Max Chl Dpth (ft)	5.19	Hydr. Depth (ft)		3.41
Conv. Total (cfs)	12544.1	Conv. (cfs)		12544.1
Length wtd. (ft)	82.00	wetted Per. (ft)		39.08
Min Ch El (ft)	649.10	Shear (lb/sq ft)		0.27
Alpha	1.00	Stream Power (lb/ft s)	140.50	-10.00
31.00				
Frctn Loss (ft)	0.11	Cum volume (acre-ft)	0.26	1.46
0.03				
C & E Loss (ft)	0.00	Cum SA (acres)	0.58	0.44
0.17				

Note: Multiple critical depths were found at this location. The critical depth with the lowest, valid, energy was used.

CROSS SECTION OUTPUT Profile #PF 26

E.G. Elev (ft)	654.63	Element	Left OB	Channel
Right OB				
Vel Head (ft)	0.26	wt. n-val.		0.030
w.s. Elev (ft)	654.38	Reach Len. (ft)	76.00	82.00
60.00				
Crit w.s. (ft)	652.35	Flow Area (sq ft)		123.00
E.G. Slope (ft/ft)	0.001494	Area (sq ft)		123.00
Q Total (cfs)	500.00	Flow (cfs)		500.00
Top width (ft)	35.81	Top width (ft)		35.81
Vel Total (ft/s)	4.07	Avg. vel. (ft/s)		4.07
Max Chl Dpth (ft)	5.28	Hydr. Depth (ft)		3.43
Conv. Total (cfs)	12936.6	Conv. (cfs)		12936.6
Length wtd. (ft)	82.00	wetted Per. (ft)		39.75
Min Ch El (ft)	649.10	Shear (lb/sq ft)		0.29
Alpha	1.00	Stream Power (lb/ft s)	140.50	-10.00
31.00				
Frctn Loss (ft)	0.12	Cum volume (acre-ft)	0.35	1.50
0.20				
C & E Loss (ft)	0.00	Cum SA (acres)	0.66	0.44

0.56

Note: Multiple critical depths were found at this location. The critical depth with the lowest, valid, energy was used.

CROSS SECTION OUTPUT Profile #PF 27

E.G. Elev (ft)	654.73	Element	Left OB	Channel
Right OB Vel Head (ft)	0.27	wt. n-val.		0.030
W.S. Elev (ft)	654.46	Reach Len. (ft)	76.00	82.00
60.00 Crit w.s. (ft)	652.42	Flow Area (sq ft)		126.12
E.G. slope (ft/ft)	0.001549	Area (sq ft)		126.12
Q Total (cfs)	525.00	Flow (cfs)		525.00
Top width (ft)	36.45	Top width (ft)		36.45
Vel Total (ft/s)	4.16	Avg. vel. (ft/s)		4.16
Max Chl Dpth (ft)	5.36	Hydr. Depth (ft)		3.46
Conv. Total (cfs)	13339.2	Conv. (cfs)		13339.2
Length wtd. (ft)	81.83	wetted Per. (ft)		40.42
Min Ch El (ft)	649.10	Shear (lb/sq ft)		0.30
Alpha	1.00	Stream Power (lb/ft s)	140.50	-10.00
31.00 Frctn Loss (ft)	0.12	Cum volume (acre-ft)	0.74	1.55
0.29 C & E Loss (ft)	0.00	Cum SA (acres)	1.83	0.44
0.73				

Note: Multiple critical depths were found at this location. The critical depth with the lowest, valid, energy was used.

CROSS SECTION OUTPUT Profile #PF 28

E.G. Elev (ft)	654.76	Element	Left OB	Channel
Right OB Vel Head (ft)	0.29	wt. n-val.		0.030
W.S. Elev (ft)	654.47	Reach Len. (ft)	76.00	82.00
60.00 Crit w.s. (ft)	652.50	Flow Area (sq ft)		126.20
E.G. slope (ft/ft)	0.001697	Area (sq ft)		126.20
Q Total (cfs)	550.00	Flow (cfs)		550.00
Top width (ft)	36.47	Top width (ft)		36.47

		westTribClow.rep		
Vel Total (ft/s)	4.36	Avg. Vel. (ft/s)		4.36
Max Chl Dpth (ft)	5.37	Hydr. Depth (ft)		3.46
Conv. Total (cfs)	13350.2	Conv. (cfs)		13350.2
Length wtd. (ft)	81.84	wetted Per. (ft)		40.43
Min Ch El (ft)	649.10	Shear (lb/sq ft)		0.33
Alpha	1.00	Stream Power (lb/ft s)	140.50	-10.00
31.00				
Frctn Loss (ft)	0.13	Cum volume (acre-ft)	0.94	1.58
0.68				
C & E Loss (ft)	0.00	Cum SA (acres)	2.02	0.44
1.22				

Note: Multiple critical depths were found at this location. The critical depth with the lowest, valid, energy was used.

CROSS SECTION OUTPUT Profile #PF 29

E.G. Elev (ft)	654.85	Element	Left OB	Channel
Right OB				
Vel Head (ft)	0.31	wt. n-val.		0.030
W.S. Elev (ft)	654.54	Reach Len. (ft)	76.00	82.00
60.00				
Crit w.s. (ft)	652.58	Flow Area (sq ft)		128.78
E.G. slope (ft/ft)	0.001765	Area (sq ft)		128.78
4.95				
Q Total (cfs)	575.00	Flow (cfs)		575.00
Top width (ft)	78.80	Top width (ft)		36.99
41.81				
Vel Total (ft/s)	4.46	Avg. vel. (ft/s)		4.46
Max Chl Dpth (ft)	5.44	Hydr. Depth (ft)		3.48
Conv. Total (cfs)	13685.9	Conv. (cfs)		13685.9
Length wtd. (ft)	81.81	wetted Per. (ft)		40.98
Min Ch El (ft)	649.10	Shear (lb/sq ft)		0.35
Alpha	1.00	Stream Power (lb/ft s)	140.50	-10.00
31.00				
Frctn Loss (ft)	0.14	Cum volume (acre-ft)	1.10	1.61
0.83				
C & E Loss (ft)	0.00	Cum SA (acres)	2.09	0.45
1.50				

Warning: Divided flow computed for this cross-section.

Note: Multiple critical depths were found at this location. The critical depth with the lowest, valid, energy was used.

CROSS SECTION OUTPUT Profile #PF 30

WestTribClow.rep

E.G. Elev (ft)	654.93	Element	Left OB	Channel
Right OB				
Vel Head (ft)	0.32	wt. n-val.		0.030
W.S. Elev (ft)	654.60	Reach Len. (ft)	76.00	82.00
60.00				
Crit W.S. (ft)	652.63	Flow Area (sq ft)		131.32
E.G. slope (ft/ft)	0.001832	Area (sq ft)		131.32
8.22				
Q Total (cfs)	600.00	Flow (cfs)		600.00
Top width (ft)	92.65	Top width (ft)		37.50
55.15				
Vel Total (ft/s)	4.57	Avg. vel. (ft/s)		4.57
Max chl Dpth (ft)	5.50	Hydr. Depth (ft)		3.50
Conv. Total (cfs)	14019.5	Conv. (cfs)		14019.5
Length wtd. (ft)	81.77	wetted Per. (ft)		41.50
Min ch El (ft)	649.10	Shear (lb/sq ft)		0.36
Alpha	1.00	Stream Power (lb/ft s)	140.50	-10.00
31.00				
Frctn Loss (ft)	0.14	Cum Volume (acre-ft)	1.28	1.64
0.95				
C & E Loss (ft)	0.00	Cum SA (acres)	2.16	0.45
1.59				

Warning: Divided flow computed for this cross-section.

Note: Multiple critical depths were found at this location. The critical depth with the lowest, valid, energy was used.

CROSS SECTION

RIVER: WestTribClow
 REACH: WestTribClow RS: 1627

INPUT

Description: Sta 16+27

Station Elevation Data				num=	23				
Sta	Elev	Sta	Elev	Sta	Elev	Sta	Elev	Sta	Elev
-132	654.4	-104	654	-50	653.7	-41	654	-20.5	654.7
-19	654	-16.5	653	-14	652	-11.5	651	-6.5	650
-3.5	649	0	648.9	1	649	9.5	650	10.5	651
11.5	652	13	653	15	654	16.5	654.3	18	654
23	653.5	44	654	62	654.3				

Manning's n Values				num=	3
Sta	n Val	Sta	n Val	Sta	n Val
-132	.08	-19	.03	15	.08

Bank Sta:	Left	Right	Lengths:	Left Channel	Right	Coeff Contr.	Expan.
	-19	15		147	127	147	.1
Ineffective Flow			num=	2			.3
Sta L	Sta R	Elev	Permanent				

westTribClow.rep

-132 -20.5 658.1 F
 55 62 658.6 F
 Left Levee Station= -20.5 Elevation= 654.8
 Right Levee Station= 16.5 Elevation= 654.3

CROSS SECTION OUTPUT Profile #PF 1

E.G. Elev (ft)	649.77	Element	Left OB	Channel
Right OB				
Vel Head (ft)	0.03	wt. n-val.		0.030
W.S. Elev (ft)	649.74	Reach Len. (ft)	147.00	127.00
147.00				
Crit w.s. (ft)	649.41	Flow Area (sq ft)		6.67
E.G. Slope (ft/ft)	0.002263	Area (sq ft)		6.67
Q Total (cfs)	10.00	Flow (cfs)		10.00
Top width (ft)	12.98	Top width (ft)		12.98
Vel Total (ft/s)	1.50	Avg. Vel. (ft/s)		1.50
Max chl Dpth (ft)	0.84	Hydr. Depth (ft)		0.51
Conv. Total (cfs)	210.2	Conv. (cfs)		210.2
Length wtd. (ft)	127.00	wetted Per. (ft)		13.15
Min ch El (ft)	648.90	Shear (lb/sq ft)		0.07
Alpha	1.00	Stream Power (lb/ft s)	62.00	-20.50
16.50				
Frctn Loss (ft)	0.31	Cum Volume (acre-ft)		0.08
C & E Loss (ft)	0.00	Cum SA (acres)		0.14

Note: Multiple critical depths were found at this location. The critical depth with the lowest, valid, energy was used.

CROSS SECTION OUTPUT Profile #PF 2

E.G. Elev (ft)	650.10	Element	Left OB	Channel
Right OB				
Vel Head (ft)	0.05	wt. n-val.		0.030
W.S. Elev (ft)	650.05	Reach Len. (ft)	147.00	127.00
147.00				
Crit w.s. (ft)	649.62	Flow Area (sq ft)		11.35
E.G. Slope (ft/ft)	0.002099	Area (sq ft)		11.35
Q Total (cfs)	20.00	Flow (cfs)		20.00
Top width (ft)	16.32	Top width (ft)		16.32
Vel Total (ft/s)	1.76	Avg. Vel. (ft/s)		1.76

Max Chl Dpth (ft)	1.15	westTribClow.rep Hydr. Depth (ft)		0.70
Conv. Total (cfs)	436.5	Conv. (cfs)		436.5
Length Wtd. (ft)	127.00	wetted Per. (ft)		16.58
Min Ch El (ft)	648.90	Shear (lb/sq ft)		0.09
Alpha 16.50	1.00	Stream Power (lb/ft s)	62.00	-20.50
Frctn Loss (ft)	0.26	Cum Volume (acre-ft)		0.14
C & E Loss (ft)	0.00	Cum SA (acres)		0.17

Note: Multiple critical depths were found at this location. The critical depth with the lowest, valid, energy was used.

CROSS SECTION OUTPUT Profile #PF 3

E.G. Elev (ft)	650.36	Element	Left OB	Channel
Right OB Vel Head (ft)	0.06	wt. n-val.		0.030
w.s. Elev (ft)	650.30	Reach Len. (ft)	147.00	127.00
147.00 Crit w.s. (ft)	649.78	Flow Area (sq ft)		15.58
E.G. Slope (ft/ft)	0.001857	Area (sq ft)		15.58
Q Total (cfs)	30.00	Flow (cfs)		30.00
Top width (ft)	17.81	Top width (ft)		17.81
Vel Total (ft/s)	1.92	Avg. Vel. (ft/s)		1.92
Max Chl Dpth (ft)	1.40	Hydr. Depth (ft)		0.87
Conv. Total (cfs)	696.2	Conv. (cfs)		696.2
Length Wtd. (ft)	127.00	wetted Per. (ft)		18.20
Min Ch El (ft)	648.90	Shear (lb/sq ft)		0.10
Alpha 16.50	1.00	Stream Power (lb/ft s)	62.00	-20.50
Frctn Loss (ft)	0.23	Cum Volume (acre-ft)		0.18
C & E Loss (ft)	0.00	Cum SA (acres)		0.20

Note: Multiple critical depths were found at this location. The critical depth with the lowest, valid, energy was used.

CROSS SECTION OUTPUT Profile #PF 4

E.G. Elev (ft)	650.58	Element	Left OB	Channel
----------------	--------	---------	---------	---------

westTribClow.rep

Right OB				
Vel Head (ft)	0.07	wt. n-val.		0.030
W.S. Elev (ft)	650.51	Reach Len. (ft)	147.00	127.00
147.00				
Crit w.s. (ft)	649.91	Flow Area (sq ft)		19.44
E.G. Slope (ft/ft)	0.001740	Area (sq ft)		19.44
Q Total (cfs)	40.00	Flow (cfs)		40.00
Top width (ft)	19.07	Top width (ft)		19.07
Vel Total (ft/s)	2.06	Avg. Vel. (ft/s)		2.06
Max Chl Dpth (ft)	1.61	Hydr. Depth (ft)		1.02
Conv. Total (cfs)	959.0	Conv. (cfs)		959.0
Length wtd. (ft)	127.00	wetted Per. (ft)		19.56
Min ch El (ft)	648.90	Shear (lb/sq ft)		0.11
Alpha	1.00	Stream Power (lb/ft s)	62.00	-20.50
16.50				
Frctn Loss (ft)	0.21	Cum Volume (acre-ft)		0.23
C & E Loss (ft)	0.00	Cum SA (acres)		0.21

Note: Multiple critical depths were found at this location. The critical depth with the lowest, valid, energy was used.

CROSS SECTION OUTPUT Profile #PF 5

E.G. Elev (ft)	650.77	Element	Left OB	Channel
Right OB				
Vel Head (ft)	0.07	wt. n-val.		0.030
W.S. Elev (ft)	650.70	Reach Len. (ft)	147.00	127.00
147.00				
Crit w.s. (ft)	650.02	Flow Area (sq ft)		23.07
E.G. Slope (ft/ft)	0.001663	Area (sq ft)		23.07
Q Total (cfs)	50.00	Flow (cfs)		50.00
Top width (ft)	20.18	Top width (ft)		20.18
Vel Total (ft/s)	2.17	Avg. Vel. (ft/s)		2.17
Max Chl Dpth (ft)	1.80	Hydr. Depth (ft)		1.14
Conv. Total (cfs)	1226.1	Conv. (cfs)		1226.1
Length wtd. (ft)	127.00	wetted Per. (ft)		20.76
Min ch El (ft)	648.90	Shear (lb/sq ft)		0.12
Alpha	1.00	Stream Power (lb/ft s)	62.00	-20.50

WestTribClow.rep

16.50			
Frctn Loss (ft)	0.21	Cum volume (acre-ft)	0.26
C & E Loss (ft)	0.00	Cum SA (acres)	0.22

Note: Multiple critical depths were found at this location. The critical depth with the lowest, valid, energy was used.

CROSS SECTION OUTPUT Profile #PF 6

E.G. Elev (ft)	650.94	Element	Left OB	Channel
Right OB				
Vel Head (ft)	0.08	wt. n-val.		0.030
W.S. Elev (ft)	650.87	Reach Len. (ft)	147.00	127.00
147.00				
Crit w.s. (ft)	650.11	Flow Area (sq ft)		26.56
E.G. Slope (ft/ft)	0.001604	Area (sq ft)		26.56
Q Total (cfs)	60.00	Flow (cfs)		60.00
Top width (ft)	21.19	Top width (ft)		21.19
Vel Total (ft/s)	2.26	Avg. Vel. (ft/s)		2.26
Max Chl Dpth (ft)	1.97	Hydr. Depth (ft)		1.25
Conv. Total (cfs)	1497.9	Conv. (cfs)		1497.9
Length wtd. (ft)	127.00	wetted Per. (ft)		21.86
Min Ch El (ft)	648.90	Shear (lb/sq ft)		0.12
Alpha	1.00	Stream Power (lb/ft s)	62.00	-20.50
16.50				
Frctn Loss (ft)	0.20	Cum Volume (acre-ft)		0.30
C & E Loss (ft)	0.00	Cum SA (acres)		0.23

Note: Multiple critical depths were found at this location. The critical depth with the lowest, valid, energy was used.

CROSS SECTION OUTPUT Profile #PF 7

E.G. Elev (ft)	651.10	Element	Left OB	Channel
Right OB				
Vel Head (ft)	0.09	wt. n-val.		0.030
W.S. Elev (ft)	651.02	Reach Len. (ft)	147.00	127.00
147.00				
Crit w.s. (ft)	650.20	Flow Area (sq ft)		29.86
E.G. Slope (ft/ft)	0.001564	Area (sq ft)		29.86

westTribClow.rep			
Q Total (cfs)	70.00	Flow (cfs)	70.00
Top width (ft)	22.06	Top width (ft)	22.06
Vel Total (ft/s)	2.34	Avg. Vel. (ft/s)	2.34
Max Chl Dpth (ft)	2.12	Hydr. Depth (ft)	1.35
Conv. Total (cfs)	1770.2	Conv. (cfs)	1770.2
Length Wtd. (ft)	127.00	wetted Per. (ft)	22.81
Min Ch El (ft)	648.90	Shear (lb/sq ft)	0.13
Alpha 16.50	1.00	Stream Power (lb/ft s)	62.00
Frctn Loss (ft)	0.20	Cum Volume (acre-ft)	0.33
C & E Loss (ft)	0.00	Cum SA (acres)	0.24

Note: Multiple critical depths were found at this location. The critical depth with the lowest, valid, energy was used.

CROSS SECTION OUTPUT Profile #PF 8

E.G. Elev (ft)	651.25	Element	Left OB	Channel
Right OB Vel Head (ft)	0.09	wt. n-Val.		0.030
W.S. Elev (ft)	651.16	Reach Len. (ft)	147.00	127.00
147.00 Crit W.S. (ft)	650.28	Flow Area (sq ft)		32.97
E.G. Slope (ft/ft)	0.001518	Area (sq ft)		32.97
Q Total (cfs)	80.00	Flow (cfs)		80.00
Top width (ft)	22.55	Top width (ft)		22.55
Vel Total (ft/s)	2.43	Avg. Vel. (ft/s)		2.43
Max Chl Dpth (ft)	2.26	Hydr. Depth (ft)		1.46
Conv. Total (cfs)	2053.1	Conv. (cfs)		2053.1
Length Wtd. (ft)	127.00	wetted Per. (ft)		23.38
Min Ch El (ft)	648.90	Shear (lb/sq ft)		0.13
Alpha 16.50	1.00	Stream Power (lb/ft s)	62.00	-20.50
Frctn Loss (ft)	0.20	Cum Volume (acre-ft)		0.36
C & E Loss (ft)	0.00	Cum SA (acres)		0.25

Note: Multiple critical depths were found at this location. The critical depth
Page 105

with the lowest, valid, energy was used.

CROSS SECTION OUTPUT Profile #PF 9

E.G. Elev (ft)	651.39	Element	Left OB	Channel
Right OB Vel Head (ft)	0.10	wt. n-val.		0.030
W.S. Elev (ft)	651.29	Reach Len. (ft)	147.00	127.00
147.00 Crit w.s. (ft)	650.36	Flow Area (sq ft)		35.96
E.G. Slope (ft/ft)	0.001483	Area (sq ft)		35.96
Q Total (cfs)	90.00	Flow (cfs)		90.00
Top width (ft)	23.01	Top width (ft)		23.01
Vel Total (ft/s)	2.50	Avg. vel. (ft/s)		2.50
Max chl Dpth (ft)	2.39	Hydr. Depth (ft)		1.56
Conv. Total (cfs)	2336.8	Conv. (cfs)		2336.8
Length wtd. (ft)	127.00	wetted Per. (ft)		23.92
Min Ch El (ft)	648.90	Shear (lb/sq ft)		0.14
Alpha	1.00	Stream Power (lb/ft s)	62.00	-20.50
16.50 Frctn Loss (ft)	0.20	Cum Volume (acre-ft)		0.39
C & E Loss (ft)	0.00	Cum SA (acres)		0.25

Note: Multiple critical depths were found at this location. The critical depth with the lowest, valid, energy was used.

CROSS SECTION OUTPUT Profile #PF 10

E.G. Elev (ft)	651.52	Element	Left OB	Channel
Right OB Vel Head (ft)	0.10	wt. n-val.		0.030
W.S. Elev (ft)	651.41	Reach Len. (ft)	147.00	127.00
147.00 Crit w.s. (ft)	650.43	Flow Area (sq ft)		38.84
E.G. Slope (ft/ft)	0.001456	Area (sq ft)		38.84
Q Total (cfs)	100.00	Flow (cfs)		100.00
Top width (ft)	23.44	Top width (ft)		23.44
Vel Total (ft/s)	2.57	Avg. vel. (ft/s)		2.57
Max chl Dpth (ft)	2.51	Hydr. Depth (ft)		1.66
Conv. Total (cfs)	2620.4	Conv. (cfs)		2620.4

westTribClow.rep

Length Wtd. (ft)	127.00	Wetted Per. (ft)		24.43
Min Ch El (ft)	648.90	Shear (lb/sq ft)		0.14
Alpha 16.50	1.00	Stream Power (lb/ft s)	62.00	-20.50
Frctn Loss (ft)	0.20	Cum Volume (acre-ft)		0.42
C & E Loss (ft)	0.00	Cum SA (acres)		0.26

Note: Multiple critical depths were found at this location. The critical depth with the lowest, valid, energy was used.

CROSS SECTION OUTPUT Profile #PF 11

E.G. Elev (ft)	651.81	Element	Left OB	Channel
Right OB Vel Head (ft)	0.12	wt. n-Val.		0.030
W.S. Elev (ft)	651.70	Reach Len. (ft)	147.00	127.00
147.00 Crit w.s. (ft)	650.59	Flow Area (sq ft)		45.66
E.G. Slope (ft/ft)	0.001413	Area (sq ft)		45.66
Q Total (cfs)	125.00	Flow (cfs)		125.00
Top width (ft)	24.44	Top width (ft)		24.44
Vel Total (ft/s)	2.74	Avg. Vel. (ft/s)		2.74
Max Chl Dpth (ft)	2.80	Hydr. Depth (ft)		1.87
Conv. Total (cfs)	3325.7	Conv. (cfs)		3325.7
Length Wtd. (ft)	127.00	wetted Per. (ft)		25.60
Min Ch El (ft)	648.90	Shear (lb/sq ft)		0.16
Alpha 16.50	1.00	Stream Power (lb/ft s)	62.00	-20.50
Frctn Loss (ft)	0.20	Cum Volume (acre-ft)		0.49
C & E Loss (ft)	0.00	Cum SA (acres)		0.27

Note: Multiple critical depths were found at this location. The critical depth with the lowest, valid, energy was used.

CROSS SECTION OUTPUT Profile #PF 12

E.G. Elev (ft)	652.08	Element	Left OB	Channel
Right OB Vel Head (ft)	0.13	wt. n-Val.		0.030

westTribClow.rep			
W.S. Elev (ft)	651.95	Reach Len. (ft)	147.00
147.00			
Crit w.s. (ft)	650.75	Flow Area (sq ft)	52.05
E.G. Slope (ft/ft)	0.001387	Area (sq ft)	52.05
Q Total (cfs)	150.00	Flow (cfs)	150.00
Top width (ft)	25.34	Top width (ft)	25.34
Vel Total (ft/s)	2.88	Avg. Vel. (ft/s)	2.88
Max Chl Dpth (ft)	3.05	Hydr. Depth (ft)	2.05
Conv. Total (cfs)	4027.0	Conv. (cfs)	4027.0
Length wtd. (ft)	127.00	wetted Per. (ft)	26.66
Min Ch El (ft)	648.90	Shear (lb/sq ft)	0.17
Alpha	1.00	Stream Power (lb/ft s)	62.00
16.50			
Frctn Loss (ft)	0.20	Cum Volume (acre-ft)	0.55
C & E Loss (ft)	0.00	Cum SA (acres)	0.28

Note: Multiple critical depths were found at this location. The critical depth with the lowest, valid, energy was used.

CROSS SECTION OUTPUT Profile #PF 13

E.G. Elev (ft)	652.33	Element	Left OB	Channel
Right OB				
Vel Head (ft)	0.14	wt. n-Val.		0.030
W.S. Elev (ft)	652.19	Reach Len. (ft)	147.00	127.00
147.00				
Crit w.s. (ft)	650.90	Flow Area (sq ft)		58.13
E.G. Slope (ft/ft)	0.001375	Area (sq ft)		58.13
Q Total (cfs)	175.00	Flow (cfs)		175.00
Top width (ft)	26.26	Top width (ft)		26.26
Vel Total (ft/s)	3.01	Avg. Vel. (ft/s)		3.01
Max Chl Dpth (ft)	3.29	Hydr. Depth (ft)		2.21
Conv. Total (cfs)	4719.6	Conv. (cfs)		4719.6
Length wtd. (ft)	127.00	wetted Per. (ft)		27.70
Min Ch El (ft)	648.90	Shear (lb/sq ft)		0.18
Alpha	1.00	Stream Power (lb/ft s)	62.00	-20.50
16.50				
Frctn Loss (ft)	0.20	Cum Volume (acre-ft)		0.61

C & E Loss (ft)	0.01	westTribClow.rep Cum SA (acres)	0.29
-----------------	------	------------------------------------	------

Note: Multiple critical depths were found at this location. The critical depth with the lowest, valid, energy was used.

CROSS SECTION OUTPUT Profile #PF 14

E.G. Elev (ft)	652.56	Element	Left OB	Channel
Right OB Vel Head (ft)	0.15	wt. n-val.		0.030
W.S. Elev (ft)	652.41	Reach Len. (ft)	147.00	127.00
147.00 Crit w.s. (ft)	651.03	Flow Area (sq ft)		63.98
E.G. Slope (ft/ft)	0.001367	Area (sq ft)		63.98
Q Total (cfs)	200.00	Flow (cfs)		200.00
Top width (ft)	27.13	Top width (ft)		27.13
Vel Total (ft/s)	3.13	Avg. vel. (ft/s)		3.13
Max Chl Dpth (ft)	3.51	Hydr. Depth (ft)		2.36
Conv. Total (cfs)	5409.7	Conv. (cfs)		5409.7
Length wtd. (ft)	127.00	wetted Per. (ft)		28.68
Min Ch El (ft)	648.90	Shear (lb/sq ft)		0.19
Alpha	1.00	Stream Power (lb/ft s)	62.00	-20.50
16.50 Frctn Loss (ft)	0.20	Cum Volume (acre-ft)		0.67
C & E Loss (ft)	0.01	Cum SA (acres)		0.30

Note: Multiple critical depths were found at this location. The critical depth with the lowest, valid, energy was used.

CROSS SECTION OUTPUT Profile #PF 15

E.G. Elev (ft)	652.78	Element	Left OB	Channel
Right OB Vel Head (ft)	0.16	wt. n-val.		0.030
W.S. Elev (ft)	652.61	Reach Len. (ft)	147.00	127.00
147.00 Crit w.s. (ft)	651.16	Flow Area (sq ft)		69.64
E.G. Slope (ft/ft)	0.001360	Area (sq ft)		69.64
Q Total (cfs)	225.00	Flow (cfs)		225.00
Top width (ft)	27.96	Top width (ft)		27.96

westTribClow.rep

Vel Total (ft/s)	3.23	Avg. Vel. (ft/s)		3.23
Max Chl Dpth (ft)	3.71	Hydr. Depth (ft)		2.49
Conv. Total (cfs)	6101.1	Conv. (cfs)		6101.1
Length Wtd. (ft)	127.00	wetted Per. (ft)		29.61
Min Ch El (ft)	648.90	Shear (lb/sq ft)		0.20
Alpha	1.00	Stream Power (lb/ft s)	62.00	-20.50
16.50				
Frctn Loss (ft)	0.20	Cum Volume (acre-ft)		0.73
C & E Loss (ft)	0.01	Cum SA (acres)		0.31

Note: Multiple critical depths were found at this location. The critical depth with the lowest, valid, energy was used.

CROSS SECTION OUTPUT Profile #PF 16

E.G. Elev (ft)	652.98	Element	Left OB	Channel
Right OB				
Vel Head (ft)	0.17	wt. n-Val.		0.030
w.s. Elev (ft)	652.81	Reach Len. (ft)	147.00	127.00
147.00				
Crit w.s. (ft)	651.26	Flow Area (sq ft)		75.16
E.G. Slope (ft/ft)	0.001354	Area (sq ft)		75.16
Q Total (cfs)	250.00	Flow (cfs)		250.00
Top width (ft)	28.74	Top width (ft)		28.74
Vel Total (ft/s)	3.33	Avg. Vel. (ft/s)		3.33
Max Chl Dpth (ft)	3.91	Hydr. Depth (ft)		2.62
Conv. Total (cfs)	6794.8	Conv. (cfs)		6794.8
Length Wtd. (ft)	127.00	wetted Per. (ft)		30.48
Min Ch El (ft)	648.90	Shear (lb/sq ft)		0.21
Alpha	1.00	Stream Power (lb/ft s)	62.00	-20.50
16.50				
Frctn Loss (ft)	0.20	Cum Volume (acre-ft)		0.79
C & E Loss (ft)	0.01	Cum SA (acres)		0.32

Note: Multiple critical depths were found at this location. The critical depth with the lowest, valid, energy was used.

CROSS SECTION OUTPUT Profile #PF 17

westTribClow.rep

E.G. Elev (ft)	653.17	Element	Left OB	Channel
Right OB Vel Head (ft)	0.18	wt. n-val.		0.030
W.S. Elev (ft)	652.99	Reach Len. (ft)	147.00	127.00
147.00 Crit w.s. (ft)	651.38	Flow Area (sq ft)		80.53
E.G. Slope (ft/ft)	0.001349	Area (sq ft)		80.53
Q Total (cfs)	275.00	Flow (cfs)		275.00
Top width (ft)	29.47	Top width (ft)		29.47
Vel Total (ft/s)	3.41	Avg. Vel. (ft/s)		3.41
Max chl Dpth (ft)	4.09	Hydr. Depth (ft)		2.73
Conv. Total (cfs)	7487.8	Conv. (cfs)		7487.8
Length wtd. (ft)	127.00	wetted Per. (ft)		31.31
Min ch El (ft)	648.90	Shear (lb/sq ft)		0.22
Alpha	1.00	Stream Power (lb/ft s)	62.00	-20.50
16.50 Frctn Loss (ft)	0.20	Cum Volume (acre-ft)		0.84
C & E Loss (ft)	0.01	Cum SA (acres)		0.32

Note: Multiple critical depths were found at this location. The critical depth with the lowest, valid, energy was used.

CROSS SECTION OUTPUT Profile #PF 18

E.G. Elev (ft)	653.36	Element	Left OB	Channel
Right OB Vel Head (ft)	0.19	wt. n-val.		0.030
W.S. Elev (ft)	653.17	Reach Len. (ft)	147.00	127.00
147.00 Crit w.s. (ft)	651.48	Flow Area (sq ft)		85.79
E.G. Slope (ft/ft)	0.001348	Area (sq ft)		85.79
Q Total (cfs)	300.00	Flow (cfs)		300.00
Top width (ft)	30.26	Top width (ft)		30.26
Vel Total (ft/s)	3.50	Avg. Vel. (ft/s)		3.50
Max chl Dpth (ft)	4.27	Hydr. Depth (ft)		2.83
Conv. Total (cfs)	8170.1	Conv. (cfs)		8170.1
Length wtd. (ft)	127.00	wetted Per. (ft)		32.18

Min Ch El (ft)	648.90	westTribClow.rep Shear (lb/sq ft)		0.22
Alpha 16.50	1.00	Stream Power (lb/ft s)	62.00	-20.50
Frctn Loss (ft)	0.20	Cum volume (acre-ft)		0.89
C & E Loss (ft)	0.01	Cum SA (acres)		0.33

Note: Multiple critical depths were found at this location. The critical depth with the lowest, valid, energy was used.

CROSS SECTION OUTPUT Profile #PF 19

E.G. Elev (ft)	653.54	Element	Left OB	Channel
Right OB Vel Head (ft)	0.20	wt. n-val.		0.030
W.S. Elev (ft)	653.34	Reach Len. (ft)	147.00	127.00
147.00 Crit w.s. (ft)	651.57	Flow Area (sq ft)		90.92
E.G. Slope (ft/ft)	0.001349	Area (sq ft)		90.92
Q Total (cfs)	325.00	Flow (cfs)		325.00
Top width (ft)	31.02	Top width (ft)		31.02
Vel Total (ft/s)	3.57	Avg. vel. (ft/s)		3.57
Max Chl Dpth (ft)	4.44	Hydr. Depth (ft)		2.93
Conv. Total (cfs)	8849.2	Conv. (cfs)		8849.2
Length wtd. (ft)	127.00	wetted Per. (ft)		33.00
Min Ch El (ft)	648.90	Shear (lb/sq ft)		0.23
Alpha 16.50	1.00	Stream Power (lb/ft s)	62.00	-20.50
Frctn Loss (ft)	0.20	Cum Volume (acre-ft)	0.00	0.95
0.00 C & E Loss (ft)	0.01	Cum SA (acres)	0.00	0.34
0.00				

Note: Multiple critical depths were found at this location. The critical depth with the lowest, valid, energy was used.

CROSS SECTION OUTPUT Profile #PF 20

E.G. Elev (ft)	653.70	Element	Left OB	Channel
Right OB Vel Head (ft)	0.21	wt. n-val.		0.030
W.S. Elev (ft)	653.49	Reach Len. (ft)	147.00	127.00
147.00 Crit w.s. (ft)	651.69	Flow Area (sq ft)		95.81

westTribClow.rep

E.G. Slope (ft/ft)	0.001354	Area (sq ft)		95.81
Q Total (cfs)	350.00	Flow (cfs)		350.00
Top width (ft)	31.72	Top width (ft)		31.72
Vel Total (ft/s)	3.65	Avg. Vel. (ft/s)		3.65
Max Chl Dpth (ft)	4.59	Hydr. Depth (ft)		3.02
Conv. Total (cfs)	9510.3	Conv. (cfs)		9510.3
Length Wtd. (ft)	127.00	wetted Per. (ft)		33.77
Min Ch El (ft)	648.90	Shear (lb/sq ft)		0.24
Alpha	1.00	Stream Power (lb/ft s)	62.00	-20.50
16.50				
Frctn Loss (ft)	0.20	Cum Volume (acre-ft)	0.00	1.00
0.00				
C & E Loss (ft)	0.01	Cum SA (acres)	0.00	0.34
0.01				

Note: Multiple critical depths were found at this location. The critical depth with the lowest, valid, energy was used.

CROSS SECTION OUTPUT Profile #PF 21

E.G. Elev (ft)	653.86	Element	Left OB	Channel
Right OB				
Vel Head (ft)	0.22	wt. n-Val.		0.030
w.s. Elev (ft)	653.64	Reach Len. (ft)	147.00	127.00
147.00				
Crit w.s. (ft)	651.79	Flow Area (sq ft)		100.64
E.G. Slope (ft/ft)	0.001358	Area (sq ft)		100.64
Q Total (cfs)	375.00	Flow (cfs)		375.00
Top width (ft)	32.40	Top width (ft)		32.40
Vel Total (ft/s)	3.73	Avg. Vel. (ft/s)		3.73
Max Chl Dpth (ft)	4.74	Hydr. Depth (ft)		3.11
Conv. Total (cfs)	10174.5	Conv. (cfs)		10174.5
Length Wtd. (ft)	127.00	wetted Per. (ft)		34.51
Min Ch El (ft)	648.90	Shear (lb/sq ft)		0.25
Alpha	1.00	Stream Power (lb/ft s)	62.00	-20.50
16.50				
Frctn Loss (ft)	0.20	Cum Volume (acre-ft)	0.00	1.05
0.00				
C & E Loss (ft)	0.01	Cum SA (acres)	0.00	0.35
0.01				

WestTribClow.rep

Note: Multiple critical depths were found at this location. The critical depth with the lowest, valid, energy was used.

CROSS SECTION OUTPUT Profile #PF 22

E.G. Elev (ft)	654.02	Element	Left OB	Channel
Right OB Vel Head (ft)	0.22	wt. n-val.		0.030
W.S. Elev (ft)	653.79	Reach Len. (ft)	147.00	127.00
147.00 Crit w.s. (ft)	651.87	Flow Area (sq ft)		105.56
E.G. Slope (ft/ft)	0.001356	Area (sq ft)		105.56
Q Total (cfs)	400.00	Flow (cfs)		400.00
Top width (ft)	33.07	Top width (ft)		33.07
Vel Total (ft/s)	3.79	Avg. Vel. (ft/s)		3.79
Max chl Dpth (ft)	4.89	Hydr. Depth (ft)		3.19
Conv. Total (cfs)	10862.2	Conv. (cfs)		10862.2
Length wtd. (ft)	127.01	wetted Per. (ft)		35.26
Min ch El (ft)	648.90	Shear (lb/sq ft)		0.25
Alpha	1.00	Stream Power (lb/ft s)	62.00	-20.50
16.50 Frctn Loss (ft)	0.20	Cum Volume (acre-ft)	0.00	1.10
0.00 C & E Loss (ft)	0.01	Cum SA (acres)	0.00	0.36
0.01				

Note: Multiple critical depths were found at this location. The critical depth with the lowest, valid, energy was used.

CROSS SECTION OUTPUT Profile #PF 23

E.G. Elev (ft)	654.17	Element	Left OB	Channel
Right OB Vel Head (ft)	0.23	wt. n-val.		0.030
W.S. Elev (ft)	653.94	Reach Len. (ft)	147.00	127.00
147.00 Crit w.s. (ft)	651.96	Flow Area (sq ft)		110.39
E.G. Slope (ft/ft)	0.001355	Area (sq ft)		110.39
Q Total (cfs)	425.00	Flow (cfs)		425.00
Top width (ft)	33.72	Top width (ft)		33.72
Vel Total (ft/s)	3.85	Avg. Vel. (ft/s)		3.85

	westTribClow.rep			
Max Chl Dpth (ft)	5.04	Hydr. Depth (ft)		3.27
Conv. Total (cfs)	11546.9	Conv. (cfs)		11546.9
Length Wtd. (ft)	127.02	wetted Per. (ft)		35.97
Min Ch El (ft)	648.90	Shear (lb/sq ft)		0.26
Alpha	1.00	Stream Power (lb/ft s)	62.00	-20.50
16.50				
Frctn Loss (ft)	0.20	Cum Volume (acre-ft)	0.00	1.14
0.01				
C & E Loss (ft)	0.01	Cum SA (acres)	0.00	0.36
0.02				

Note: Multiple critical depths were found at this location. The critical depth with the lowest, valid, energy was used.

CROSS SECTION OUTPUT Profile #PF 24

		Element	Left OB	Channel
E.G. Elev (ft)	654.31			
Right OB				
Vel Head (ft)	0.24	wt. n-val.	0.080	0.030
0.080				
W.S. Elev (ft)	654.08	Reach Len. (ft)	147.00	127.00
147.00				
Crit w.s. (ft)	652.05	Flow Area (sq ft)	0.01	115.02
0.01				
E.G. Slope (ft/ft)	0.001339	Area (sq ft)	0.01	115.02
0.01				
Q Total (cfs)	450.00	Flow (cfs)	0.00	450.00
0.00				
Top width (ft)	34.54	Top width (ft)	0.16	34.00
0.37				
Vel Total (ft/s)	3.91	Avg. Vel. (ft/s)	0.07	3.91
0.08				
Max Chl Dpth (ft)	5.17	Hydr. Depth (ft)	0.04	3.38
0.04				
Conv. Total (cfs)	12297.3	Conv. (cfs)	0.0	12297.2
0.0				
Length wtd. (ft)	127.02	wetted Per. (ft)	0.18	36.27
0.38				
Min Ch El (ft)	648.90	Shear (lb/sq ft)	0.00	0.27
0.00				
Alpha	1.00	Stream Power (lb/ft s)	62.00	-20.50
16.50				
Frctn Loss (ft)	0.20	Cum Volume (acre-ft)	0.15	1.19
0.01				
C & E Loss (ft)	0.01	Cum SA (acres)	0.35	0.37
0.02				

Note: Multiple critical depths were found at this location. The critical depth with the lowest, valid, energy was used.

CROSS SECTION OUTPUT Profile #PF 25

E.G. Elev (ft)	654.42	Element	Left OB	Channel
		Page 115		

westTribClow.rep

Right OB				
Vel Head (ft)	0.25	wt. n-val.	0.080	0.030
0.080				
W.S. Elev (ft)	654.17	Reach Len. (ft)	147.00	127.00
147.00				
Crit w.s. (ft)	652.14	Flow Area (sq ft)	0.03	118.22
0.07				
E.G. slope (ft/ft)	0.001362	Area (sq ft)	0.03	118.22
0.07				
Q Total (cfs)	475.00	Flow (cfs)	0.00	474.99
0.01				
Top width (ft)	35.21	Top width (ft)	0.36	34.00
0.85				
Vel Total (ft/s)	4.01	Avg. Vel. (ft/s)	0.12	4.02
0.13				
Max Chl Dpth (ft)	5.27	Hydr. Depth (ft)	0.08	3.48
0.08				
Conv. Total (cfs)	12872.7	Conv. (cfs)	0.1	12872.3
0.3				
Length wtd. (ft)	127.03	wetted Per. (ft)	0.40	36.27
0.86				
Min Ch El (ft)	648.90	Shear (lb/sq ft)	0.01	0.28
0.01				
Alpha	1.00	Stream Power (lb/ft s)	62.00	-20.50
16.50				
Frctn Loss (ft)	0.20	Cum Volume (acre-ft)	0.26	1.23
0.03				
C & E Loss (ft)	0.01	Cum SA (acres)	0.58	0.37
0.17				

Note: Multiple critical depths were found at this location. The critical depth with the lowest, valid, energy was used.

CROSS SECTION OUTPUT Profile #PF 26

E.G. Elev (ft)	654.52	Element	Left OB	Channel
Right OB				
Vel Head (ft)	0.27	wt. n-val.	0.080	0.030
0.080				
W.S. Elev (ft)	654.25	Reach Len. (ft)	147.00	127.00
147.00				
Crit w.s. (ft)	652.22	Flow Area (sq ft)	0.07	120.97
0.16				
E.G. slope (ft/ft)	0.001397	Area (sq ft)	0.07	120.97
0.16				
Q Total (cfs)	500.00	Flow (cfs)	0.01	499.96
0.03				
Top width (ft)	35.79	Top width (ft)	0.54	34.00
1.25				
Vel Total (ft/s)	4.13	Avg. Vel. (ft/s)	0.16	4.13
0.17				
Max Chl Dpth (ft)	5.35	Hydr. Depth (ft)	0.12	3.56
0.12				
Conv. Total (cfs)	13376.6	Conv. (cfs)	0.3	13375.5
0.7				
Length wtd. (ft)	127.04	wetted Per. (ft)	0.59	36.27
1.27				
Min Ch El (ft)	648.90	Shear (lb/sq ft)	0.01	0.29
0.01				
Alpha	1.00	Stream Power (lb/ft s)	62.00	-20.50

WestTribClow.rep

16.50				
Frctn Loss (ft)	0.21	Cum volume (acre-ft)	0.35	1.27
0.20				
C & E Loss (ft)	0.02	Cum SA (acres)	0.66	0.37
0.56				

Note: Multiple critical depths were found at this location. The critical depth with the lowest, valid, energy was used.

CROSS SECTION OUTPUT Profile #PF 27

E.G. Elev (ft)	654.61	Element	Left OB	Channel
Right OB				
Vel Head (ft)	0.26	wt. n-val.	0.080	0.030
0.080				
W.S. Elev (ft)	654.35	Reach Len. (ft)	147.00	127.00
147.00				
Crit w.s. (ft)	652.30	Flow Area (sq ft)	0.13	124.32
18.98				
E.G. slope (ft/ft)	0.001364	Area (sq ft)	0.13	124.32
19.73				
Q Total (cfs)	525.00	Flow (cfs)	0.03	517.06
7.91				
Top width (ft)	81.75	Top width (ft)	0.75	34.00
47.00				
Vel Total (ft/s)	3.66	Avg. vel. (ft/s)	0.20	4.16
0.42				
Max Chl Dpth (ft)	5.45	Hydr. Depth (ft)	0.17	3.66
0.47				
Conv. Total (cfs)	14213.7	Conv. (cfs)	0.7	13998.8
214.2				
Length wtd. (ft)	127.19	wetted Per. (ft)	0.82	36.27
40.09				
Min Ch El (ft)	648.90	Shear (lb/sq ft)	0.01	0.29
0.04				
Alpha	1.27	Stream Power (lb/ft s)	62.00	-20.50
16.50				
Frctn Loss (ft)	0.21	Cum Volume (acre-ft)	0.74	1.31
0.28				
C & E Loss (ft)	0.02	Cum SA (acres)	1.83	0.37
0.69				

Warning: The cross-section end points had to be extended vertically for the computed water surface.

Note: Multiple critical depths were found at this location. The critical depth with the lowest, valid, energy was used.

CROSS SECTION OUTPUT Profile #PF 28

E.G. Elev (ft)	654.63	Element	Left OB	Channel
Right OB				
Vel Head (ft)	0.29	wt. n-val.	0.080	0.030
0.080				
W.S. Elev (ft)	654.34	Reach Len. (ft)	147.00	127.00
147.00				
Crit w.s. (ft)	652.39	Flow Area (sq ft)	0.12	123.93
18.52				

westTribClow.rep				
E.G. Slope (ft/ft)	0.001515	Area (sq ft)	0.12	123.93
19.18				
Q Total (cfs)	550.00	Flow (cfs)	0.03	541.98
8.00				
Top width (ft)	81.72	Top width (ft)	0.72	34.00
47.00				
Vel Total (ft/s)	3.86	Avg. Vel. (ft/s)	0.21	4.37
0.43				
Max Chl Dpth (ft)	5.44	Hydr. Depth (ft)	0.17	3.64
0.46				
Conv. Total (cfs)	14130.6	Conv. (cfs)	0.6	13924.5
205.5				
Length wtd. (ft)	127.96	wetted Per. (ft)	0.80	36.27
40.09				
Min Ch El (ft)	648.90	Shear (lb/sq ft)	0.01	0.32
0.04				
Alpha	1.27	Stream Power (lb/ft s)	62.00	-20.50
16.50				
Frctn Loss (ft)	0.21	Cum volume (acre-ft)	0.94	1.34
0.67				
C & E Loss (ft)	0.01	Cum SA (acres)	2.02	0.38
1.19				

Warning: The cross-section end points had to be extended vertically for the computed water surface.

Note: Multiple critical depths were found at this location. The critical depth with the lowest, valid, energy was used.

CROSS SECTION OUTPUT Profile #PF 29

E.G. Elev (ft)	654.71	Element	Left OB	Channel
Right OB				
Vel Head (ft)	0.31	wt. n-val.	0.080	0.030
0.080				
W.S. Elev (ft)	654.40	Reach Len. (ft)	147.00	127.00
147.00				
Crit w.s. (ft)	652.47	Flow Area (sq ft)	0.18	126.23
21.23				
E.G. Slope (ft/ft)	0.001547	Area (sq ft)	0.18	126.23
22.37				
Q Total (cfs)	575.00	Flow (cfs)	0.04	564.81
10.15				
Top width (ft)	81.87	Top width (ft)	0.87	34.00
47.00				
Vel Total (ft/s)	3.89	Avg. Vel. (ft/s)	0.24	4.47
0.48				
Max Chl Dpth (ft)	5.50	Hydr. Depth (ft)	0.20	3.71
0.53				
Conv. Total (cfs)	14617.6	Conv. (cfs)	1.1	14358.6
258.0				
Length wtd. (ft)	128.05	wetted Per. (ft)	0.96	36.27
40.09				
Min Ch El (ft)	648.90	Shear (lb/sq ft)	0.02	0.34
0.05				
Alpha	1.30	Stream Power (lb/ft s)	62.00	-20.50
16.50				
Frctn Loss (ft)	0.22	Cum volume (acre-ft)	1.10	1.37
0.81				
C & E Loss (ft)	0.01	Cum SA (acres)	2.09	0.38
1.44				

WestTribClow.rep

Warning: The cross-section end points had to be extended vertically for the computed water surface.

Note: Multiple critical depths were found at this location. The critical depth with the lowest, valid, energy was used.

CROSS SECTION OUTPUT Profile #PF 30

E.G. Elev (ft)	654.79	Element	Left OB	Channel
Right OB				
Vel Head (ft)	0.32	wt. n-val.	0.080	0.030
0.080				
W.S. Elev (ft)	654.47	Reach Len. (ft)	147.00	127.00
147.00				
Crit w.s. (ft)	652.53	Flow Area (sq ft)	0.24	128.47
23.86				
E.G. slope (ft/ft)	0.001579	Area (sq ft)	0.24	128.47
25.46				
Q Total (cfs)	600.00	Flow (cfs)	0.06	587.48
12.46				
Top width (ft)	82.01	Top width (ft)	1.01	34.00
47.00				
Vel Total (ft/s)	3.93	Avg. vel. (ft/s)	0.26	4.57
0.52				
Max Chl Dpth (ft)	5.57	Hydr. Depth (ft)	0.24	3.78
0.60				
Conv. Total (cfs)	15100.2	Conv. (cfs)	1.6	14785.2
313.5				
Length wtd. (ft)	128.13	wetted Per. (ft)	1.11	36.27
40.09				
Min Ch El (ft)	648.90	Shear (lb/sq ft)	0.02	0.35
0.06				
Alpha	1.32	Stream Power (lb/ft s)	62.00	-20.50
16.50				
Frctn Loss (ft)	0.22	Cum Volume (acre-ft)	1.28	1.40
0.92				
C & E Loss (ft)	0.01	Cum SA (acres)	2.16	0.38
1.52				

Warning: The cross-section end points had to be extended vertically for the computed water surface.

Note: Multiple critical depths were found at this location. The critical depth with the lowest, valid, energy was used.

CROSS SECTION

RIVER: WestTribClow
 REACH: WestTribClow RS: 1500

INPUT

Description: Sta: 15+00

Station Elevation Data		num= 25							
Sta	Elev	Sta	Elev	Sta	Elev	Sta	Elev	Sta	Elev
-221	654	-170.5	653.4	-132.5	653.8	-92.5	653.6	-55	653.1
-12.7	653.9	-11.7	653	-7.5	650	-6	649.2	0	648.5
4.5	649.2	8	650	9.5	651	13	653	22	654
28.5	655.8	36	654	39.5	653.2	45.5	653	59.5	652.8

74	653	108.5	653.4	westTribCflow.rep	134	653.4	161	653.7	173	654
Manning's n Values		num=		3						
Sta	n Val	Sta	n Val	Sta	n Val					
-221	.08	-11.7	.03	13	.08					
Bank Sta:	Left	Right	Lengths:	Left Channel	Right	Coeff Contr.	Expan.			
	-11.7	13		148	150	142	.1	.3		
Ineffective Flow	num=		2							
Sta L	Sta R	Elev	Permanent							
-221	-12.7	658.1	F							
87	173	658.6	F							
Left Levee	Station=		-12.7	Elevation=	653.9					
Right Levee	Station=		28.5	Elevation=	654					

CROSS SECTION OUTPUT Profile #PF 1

E.G. Elev (ft)	649.46	Element	Left OB	Channel
Right OB				
Vel Head (ft)	0.04	wt. n-Val.		0.030
W.S. Elev (ft)	649.42	Reach Len. (ft)	148.00	150.00
142.00				
Crit w.s. (ft)	649.14	Flow Area (sq ft)		6.16
E.G. Slope (ft/ft)	0.002626	Area (sq ft)		6.16
Q Total (cfs)	10.00	Flow (cfs)		10.00
Top width (ft)	11.89	Top width (ft)		11.89
Vel Total (ft/s)	1.62	Avg. Vel. (ft/s)		1.62
Max Chl Dpth (ft)	0.92	Hydr. Depth (ft)		0.52
Conv. Total (cfs)	195.2	Conv. (cfs)		195.2
Length wtd. (ft)	150.00	wetted Per. (ft)		12.07
Min Ch El (ft)	648.50	Shear (lb/sq ft)		0.08
Alpha	1.00	Stream Power (lb/ft s)	173.00	-12.70
28.50				
Frctn Loss (ft)	0.21	Cum Volume (acre-ft)		0.06
C & E Loss (ft)	0.01	Cum SA (acres)		0.11

Warning: The conveyance ratio (upstream conveyance divided by downstream conveyance) is less than 0.7 or greater than 1.4.

This may indicate the need for additional cross sections.

Note: Multiple critical depths were found at this location. The critical depth with the lowest, valid, energy was used.

CROSS SECTION OUTPUT Profile #PF 2

E.G. Elev (ft)	649.85	Element	Left OB	Channel
Right OB				
Vel Head (ft)	0.05	wt. n-Val.		0.030

WestTribClow.rep

W.S. Elev (ft)	649.79	Reach Len. (ft)	148.00	150.00
142.00 Crit w.s. (ft)	649.34	Flow Area (sq ft)		11.02
E.G. Slope (ft/ft)	0.001939	Area (sq ft)		11.02
Q Total (cfs)	20.00	Flow (cfs)		20.00
Top width (ft)	14.22	Top width (ft)		14.22
Vel Total (ft/s)	1.81	Avg. Vel. (ft/s)		1.81
Max Chl Dpth (ft)	1.29	Hydr. Depth (ft)		0.78
Conv. Total (cfs)	454.2	Conv. (cfs)		454.2
Length wtd. (ft)	150.00	wetted Per. (ft)		14.53
Min Ch El (ft)	648.50	Shear (lb/sq ft)		0.09
Alpha 28.50	1.00	Stream Power (lb/ft s)	173.00	-12.70
Frctn Loss (ft)	0.20	Cum Volume (acre-ft)		0.10
C & E Loss (ft)	0.00	Cum SA (acres)		0.13

Note: Multiple critical depths were found at this location. The critical depth with the lowest, valid, energy was used.

CROSS SECTION OUTPUT Profile #PF 3

E.G. Elev (ft)	650.13	Element	Left OB	Channel
Right OB Vel Head (ft)	0.06	wt. n-val.		0.030
W.S. Elev (ft)	650.07	Reach Len. (ft)	148.00	150.00
142.00 Crit w.s. (ft)	649.49	Flow Area (sq ft)		15.20
E.G. Slope (ft/ft)	0.001721	Area (sq ft)		15.20
Q Total (cfs)	30.00	Flow (cfs)		30.00
Top width (ft)	15.71	Top width (ft)		15.71
Vel Total (ft/s)	1.97	Avg. Vel. (ft/s)		1.97
Max Chl Dpth (ft)	1.57	Hydr. Depth (ft)		0.97
Conv. Total (cfs)	723.2	Conv. (cfs)		723.2
Length wtd. (ft)	150.00	wetted Per. (ft)		16.14
Min Ch El (ft)	648.50	Shear (lb/sq ft)		0.10
Alpha 28.50	1.00	Stream Power (lb/ft s)	173.00	-12.70
Frctn Loss (ft)	0.20	Cum Volume (acre-ft)		0.14

WestTribClow.rep

C & E Loss (ft) 0.00 Cum SA (acres) 0.15

Note: Multiple critical depths were found at this location. The critical depth with the lowest, valid, energy was used.

CROSS SECTION OUTPUT Profile #PF 4

E.G. Elev (ft)	650.36	Element	Left OB	Channel
Right OB Vel Head (ft)	0.07	wt. n-Val.		0.030
W.S. Elev (ft)	650.29	Reach Len. (ft)	148.00	150.00
142.00 Crit w.s. (ft)	649.63	Flow Area (sq ft)		18.73
E.G. slope (ft/ft)	0.001622	Area (sq ft)		18.73
Q Total (cfs)	40.00	Flow (cfs)		40.00
Top width (ft)	16.35	Top width (ft)		16.35
Vel Total (ft/s)	2.14	Avg. Vel. (ft/s)		2.14
Max Chl Dpth (ft)	1.79	Hydr. Depth (ft)		1.15
Conv. Total (cfs)	993.0	Conv. (cfs)		993.0
Length wtd. (ft)	150.00	wetted Per. (ft)		16.92
Min Ch El (ft)	648.50	Shear (lb/sq ft)		0.11
Alpha	1.00	Stream Power (lb/ft s)	173.00	-12.70
28.50 Frctn Loss (ft)	0.21	cum volume (acre-ft)		0.17
C & E Loss (ft)	0.00	Cum SA (acres)		0.16

Note: Multiple critical depths were found at this location. The critical depth with the lowest, valid, energy was used.

CROSS SECTION OUTPUT Profile #PF 5

E.G. Elev (ft)	650.56	Element	Left OB	Channel
Right OB Vel Head (ft)	0.08	wt. n-Val.		0.030
W.S. Elev (ft)	650.48	Reach Len. (ft)	148.00	150.00
142.00 Crit w.s. (ft)	649.74	Flow Area (sq ft)		21.86
E.G. slope (ft/ft)	0.001595	Area (sq ft)		21.86
Q Total (cfs)	50.00	Flow (cfs)		50.00

westTribClow.rep			
Top width (ft)	16.89	Top width (ft)	16.89
Vel Total (ft/s)	2.29	Avg. Vel. (ft/s)	2.29
Max Chl Dpth (ft)	1.98	Hydr. Depth (ft)	1.29
Conv. Total (cfs)	1251.9	Conv. (cfs)	1251.9
Length wtd. (ft)	150.00	wetted Per. (ft)	17.58
Min Ch El (ft)	648.50	Shear (lb/sq ft)	0.12
Alpha	1.00	Stream Power (lb/ft s)	173.00
Frctn Loss (ft)	0.21	Cum Volume (acre-ft)	0.20
C & E Loss (ft)	0.00	Cum SA (acres)	0.17

Note: Multiple critical depths were found at this location. The critical depth with the lowest, valid, energy was used.

CROSS SECTION OUTPUT Profile #PF 6

E.G. Elev (ft)	650.74	Element	Left OB	Channel
Right OB				
Vel Head (ft)	0.09	wt. n-Val.		0.030
W.S. Elev (ft)	650.65	Reach Len. (ft)	148.00	150.00
142.00				
Crit w.s. (ft)	649.85	Flow Area (sq ft)		24.75
E.G. Slope (ft/ft)	0.001587	Area (sq ft)		24.75
Q Total (cfs)	60.00	Flow (cfs)		60.00
Top width (ft)	17.38	Top width (ft)		17.38
Vel Total (ft/s)	2.42	Avg. Vel. (ft/s)		2.42
Max Chl Dpth (ft)	2.15	Hydr. Depth (ft)		1.42
Conv. Total (cfs)	1506.1	Conv. (cfs)		1506.1
Length wtd. (ft)	150.00	wetted Per. (ft)		18.17
Min Ch El (ft)	648.50	Shear (lb/sq ft)		0.13
Alpha	1.00	Stream Power (lb/ft s)	173.00	-12.70
28.50				
Frctn Loss (ft)	0.21	Cum Volume (acre-ft)		0.22
C & E Loss (ft)	0.00	Cum SA (acres)		0.18

Note: Multiple critical depths were found at this location. The critical depth with the lowest, valid, energy was used.

CROSS SECTION OUTPUT Profile #PF 7

E.G. Elev (ft)	650.90	Element	Left OB	Channel
Right OB Vel Head (ft)	0.10	wt. n-Val.		0.030
W.S. Elev (ft)	650.80	Reach Len. (ft)	148.00	150.00
142.00 Crit W.S. (ft)	649.94	Flow Area (sq ft)		27.38
E.G. Slope (ft/ft)	0.001602	Area (sq ft)		27.38
Q Total (cfs)	70.00	Flow (cfs)		70.00
Top width (ft)	17.82	Top width (ft)		17.82
Vel Total (ft/s)	2.56	Avg. Vel. (ft/s)		2.56
Max Chl Dpth (ft)	2.30	Hydr. Depth (ft)		1.54
Conv. Total (cfs)	1749.1	Conv. (cfs)		1749.1
Length wtd. (ft)	150.00	wetted Per. (ft)		18.70
Min Ch El (ft)	648.50	Shear (lb/sq ft)		0.15
Alpha	1.00	Stream Power (lb/ft s)	173.00	-12.70
28.50 Frctn Loss (ft)	0.22	Cum Volume (acre-ft)		0.25
C & E Loss (ft)	0.00	Cum SA (acres)		0.18

Note: Multiple critical depths were found at this location. The critical depth with the lowest, valid, energy was used.

CROSS SECTION OUTPUT Profile #PF 8

E.G. Elev (ft)	651.05	Element	Left OB	Channel
Right OB Vel Head (ft)	0.11	wt. n-Val.		0.030
W.S. Elev (ft)	650.94	Reach Len. (ft)	148.00	150.00
142.00 Crit W.S. (ft)	650.03	Flow Area (sq ft)		29.84
E.G. Slope (ft/ft)	0.001626	Area (sq ft)		29.84
Q Total (cfs)	80.00	Flow (cfs)		80.00
Top width (ft)	18.21	Top width (ft)		18.21
Vel Total (ft/s)	2.68	Avg. Vel. (ft/s)		2.68
Max Chl Dpth (ft)	2.44	Hydr. Depth (ft)		1.64
Conv. Total (cfs)	1984.2	Conv. (cfs)		1984.2
Length wtd. (ft)	150.00	wetted Per. (ft)		19.18

westTribClow.rep

Min Ch El (ft)	648.50	Shear (lb/sq ft)		0.16
Alpha	1.00	Stream Power (lb/ft s)	173.00	-12.70
28.50				
Frctn Loss (ft)	0.23	Cum Volume (acre-ft)		0.27
C & E Loss (ft)	0.00	Cum SA (acres)		0.19

Note: Multiple critical depths were found at this location. The critical depth with the lowest, valid, energy was used.

CROSS SECTION OUTPUT Profile #PF 9

E.G. Elev (ft)	651.18	Element	Left OB	Channel
Right OB				
Vel Head (ft)	0.12	wt. n-Val.		0.030
W.S. Elev (ft)	651.06	Reach Len. (ft)	148.00	150.00
142.00				
Crit w.s. (ft)	650.12	Flow Area (sq ft)		32.19
E.G. Slope (ft/ft)	0.001649	Area (sq ft)		32.19
Q Total (cfs)	90.00	Flow (cfs)		90.00
Top width (ft)	18.60	Top width (ft)		18.60
Vel Total (ft/s)	2.80	Avg. Vel. (ft/s)		2.80
Max Chl Dpth (ft)	2.56	Hydr. Depth (ft)		1.73
Conv. Total (cfs)	2216.1	Conv. (cfs)		2216.1
Length wtd. (ft)	150.00	wetted Per. (ft)		19.64
Min Ch El (ft)	648.50	Shear (lb/sq ft)		0.17
Alpha	1.00	Stream Power (lb/ft s)	173.00	-12.70
28.50				
Frctn Loss (ft)	0.24	Cum Volume (acre-ft)		0.29
C & E Loss (ft)	0.00	Cum SA (acres)		0.19

Note: Multiple critical depths were found at this location. The critical depth with the lowest, valid, energy was used.

CROSS SECTION OUTPUT Profile #PF 10

E.G. Elev (ft)	651.31	Element	Left OB	Channel
Right OB				
Vel Head (ft)	0.13	wt. n-Val.		0.030
W.S. Elev (ft)	651.18	Reach Len. (ft)	148.00	150.00
142.00				

westTribClow.rep				
Crit w.s. (ft)	650.19	Flow Area (sq ft)		34.46
E.G. Slope (ft/ft)	0.001673	Area (sq ft)		34.46
Q Total (cfs)	100.00	Flow (cfs)		100.00
Top width (ft)	18.98	Top width (ft)		18.98
Vel Total (ft/s)	2.90	Avg. Vel. (ft/s)		2.90
Max Chl Dpth (ft)	2.68	Hydr. Depth (ft)		1.82
Conv. Total (cfs)	2445.0	Conv. (cfs)		2445.0
Length wtd. (ft)	150.00	wetted Per. (ft)		20.09
Min Ch El (ft)	648.50	Shear (lb/sq ft)		0.18
Alpha	1.00	Stream Power (lb/ft s)	173.00	-12.70
Frctn Loss (ft)	0.24	Cum Volume (acre-ft)		0.31
C & E Loss (ft)	0.00	Cum SA (acres)		0.19

Note: Multiple critical depths were found at this location. The critical depth with the lowest, valid, energy was used.

CROSS SECTION OUTPUT Profile #PF 11

E.G. Elev (ft)	651.61	Element	Left OB	Channel
Right OB				
Vel Head (ft)	0.15	wt. n-val.		0.030
W.S. Elev (ft)	651.46	Reach Len. (ft)	148.00	150.00
142.00				
Crit w.s. (ft)	650.38	Flow Area (sq ft)		39.79
E.G. Slope (ft/ft)	0.001729	Area (sq ft)		39.79
Q Total (cfs)	125.00	Flow (cfs)		125.00
Top width (ft)	19.84	Top width (ft)		19.84
Vel Total (ft/s)	3.14	Avg. Vel. (ft/s)		3.14
Max Chl Dpth (ft)	2.96	Hydr. Depth (ft)		2.01
Conv. Total (cfs)	3006.4	Conv. (cfs)		3006.4
Length wtd. (ft)	150.00	wetted Per. (ft)		21.12
Min Ch El (ft)	648.50	Shear (lb/sq ft)		0.20
Alpha	1.00	Stream Power (lb/ft s)	173.00	-12.70
28.50				
Frctn Loss (ft)	0.25	Cum Volume (acre-ft)		0.36
C & E Loss (ft)	0.00	Cum SA (acres)		0.20

WestTribClow.rep

Note: Multiple critical depths were found at this location. The critical depth with the lowest, valid, energy was used.

CROSS SECTION OUTPUT Profile #PF 12

E.G. Elev (ft)	651.88	Element	Left OB	Channel
Right OB Vel Head (ft)	0.17	wt. n-Val.		0.030
W.S. Elev (ft)	651.71	Reach Len. (ft)	148.00	150.00
142.00 Crit w.s. (ft)	650.53	Flow Area (sq ft)		44.79
E.G. Slope (ft/ft)	0.001777	Area (sq ft)		44.79
Q Total (cfs)	150.00	Flow (cfs)		150.00
Top width (ft)	20.62	Top width (ft)		20.62
Vel Total (ft/s)	3.35	Avg. Vel. (ft/s)		3.35
Max Chl Dpth (ft)	3.21	Hydr. Depth (ft)		2.17
Conv. Total (cfs)	3558.3	Conv. (cfs)		3558.3
Length wtd. (ft)	150.00	wetted Per. (ft)		22.04
Min Ch El (ft)	648.50	Shear (lb/sq ft)		0.23
Alpha	1.00	Stream Power (lb/ft s)	173.00	-12.70
28.50 Frctn Loss (ft)	0.26	Cum Volume (acre-ft)		0.41
C & E Loss (ft)	0.00	Cum SA (acres)		0.21

Note: Multiple critical depths were found at this location. The critical depth with the lowest, valid, energy was used.

CROSS SECTION OUTPUT Profile #PF 13

E.G. Elev (ft)	652.13	Element	Left OB	Channel
Right OB Vel Head (ft)	0.19	wt. n-Val.		0.030
W.S. Elev (ft)	651.93	Reach Len. (ft)	148.00	150.00
142.00 Crit w.s. (ft)	650.69	Flow Area (sq ft)		49.53
E.G. Slope (ft/ft)	0.001818	Area (sq ft)		49.53
Q Total (cfs)	175.00	Flow (cfs)		175.00
Top width (ft)	21.33	Top width (ft)		21.33
Vel Total (ft/s)	3.53	Avg. Vel. (ft/s)		3.53

westTribClow.rep

Max Chl Dpth (ft)	3.43	Hydr. Depth (ft)		2.32
Conv. Total (cfs)	4103.8	Conv. (cfs)		4103.8
Length wtd. (ft)	150.00	wetted Per. (ft)		22.89
Min Ch El (ft)	648.50	Shear (lb/sq ft)		0.25
Alpha 28.50	1.00	Stream Power (lb/ft s)	173.00	-12.70
Frctn Loss (ft)	0.27	Cum Volume (acre-ft)		0.46
C & E Loss (ft)	0.00	Cum SA (acres)		0.22

Note: Multiple critical depths were found at this location. The critical depth with the lowest, valid, energy was used.

CROSS SECTION OUTPUT Profile #PF 14

E.G. Elev (ft)	652.35	Element	Left OB	Channel
Right OB Vel Head (ft)	0.21	wt. n-Val.		0.030
W.S. Elev (ft)	652.14	Reach Len. (ft)	148.00	150.00
142.00 Crit w.s. (ft)	650.84	Flow Area (sq ft)		54.07
E.G. Slope (ft/ft)	0.001854	Area (sq ft)		54.07
Q Total (cfs)	200.00	Flow (cfs)		200.00
Top width (ft)	21.99	Top width (ft)		21.99
Vel Total (ft/s)	3.70	Avg. vel. (ft/s)		3.70
Max Chl Dpth (ft)	3.64	Hydr. Depth (ft)		2.46
Conv. Total (cfs)	4644.5	Conv. (cfs)		4644.5
Length wtd. (ft)	150.00	wetted Per. (ft)		23.67
Min Ch El (ft)	648.50	Shear (lb/sq ft)		0.26
Alpha 28.50	1.00	Stream Power (lb/ft s)	173.00	-12.70
Frctn Loss (ft)	0.28	Cum Volume (acre-ft)		0.50
C & E Loss (ft)	0.00	Cum SA (acres)		0.23

Note: Multiple critical depths were found at this location. The critical depth with the lowest, valid, energy was used.

CROSS SECTION OUTPUT Profile #PF 15

		westTribClow.rep			
		Element		Left OB	Channel
E.G. Elev (ft)	652.57				
Right OB Vel Head (ft)	0.23	wt. n-Val.			0.030
W.S. Elev (ft)	652.34	Reach Len. (ft)		148.00	150.00
142.00 Crit w.s. (ft)	650.97	Flow Area (sq ft)			58.45
E.G. Slope (ft/ft)	0.001885	Area (sq ft)			58.45
Q Total (cfs)	225.00	Flow (cfs)			225.00
Top width (ft)	22.61	Top width (ft)			22.61
Vel Total (ft/s)	3.85	Avg. Vel. (ft/s)			3.85
Max Chl Dpth (ft)	3.84	Hydr. Depth (ft)			2.58
Conv. Total (cfs)	5182.8	Conv. (cfs)			5182.8
Length wtd. (ft)	150.00	wetted Per. (ft)			24.41
Min Ch El (ft)	648.50	Shear (lb/sq ft)			0.28
Alpha	1.00	Stream Power (lb/ft s)	173.00		-12.70
28.50 Frctn Loss (ft)	0.29	Cum Volume (acre-ft)			0.54
C & E Loss (ft)	0.00	Cum SA (acres)			0.23

Note: Multiple critical depths were found at this location. The critical depth with the lowest, valid, energy was used.

CROSS SECTION OUTPUT Profile #PF 16

		Element		Left OB	Channel
E.G. Elev (ft)	652.77				
Right OB Vel Head (ft)	0.25	wt. n-Val.			0.030
W.S. Elev (ft)	652.52	Reach Len. (ft)		148.00	150.00
142.00 Crit w.s. (ft)	651.12	Flow Area (sq ft)			62.72
E.G. Slope (ft/ft)	0.001910	Area (sq ft)			62.72
Q Total (cfs)	250.00	Flow (cfs)			250.00
Top width (ft)	23.20	Top width (ft)			23.20
Vel Total (ft/s)	3.99	Avg. Vel. (ft/s)			3.99
Max Chl Dpth (ft)	4.02	Hydr. Depth (ft)			2.70
Conv. Total (cfs)	5720.5	Conv. (cfs)			5720.5
Length wtd. (ft)	150.00	wetted Per. (ft)			25.10
Min Ch El (ft)	648.50	Shear (lb/sq ft)			0.30

	westTribClow.rep		
Alpha	1.00	Stream Power (lb/ft s)	173.00
28.50			-12.70
Frctn Loss (ft)	0.29	Cum Volume (acre-ft)	0.58
C & E Loss (ft)	0.00	Cum SA (acres)	0.24

Note: Multiple critical depths were found at this location. The critical depth with the lowest, valid, energy was used.

CROSS SECTION OUTPUT Profile #PF 17

		Element	Left OB	Channel
E.G. Elev (ft)	652.96			
Right OB				
Vel Head (ft)	0.26	wt. n-Val.		0.030
W.S. Elev (ft)	652.70	Reach Len. (ft)	148.00	150.00
142.00				
Crit w.s. (ft)	651.25	Flow Area (sq ft)		66.87
E.G. Slope (ft/ft)	0.001933	Area (sq ft)		66.87
Q Total (cfs)	275.00	Flow (cfs)		275.00
Top width (ft)	23.76	Top width (ft)		23.76
Vel Total (ft/s)	4.11	Avg. Vel. (ft/s)		4.11
Max Chl Dpth (ft)	4.20	Hydr. Depth (ft)		2.81
Conv. Total (cfs)	6255.1	Conv. (cfs)		6255.1
Length wtd. (ft)	150.00	wetted Per. (ft)		25.76
Min Ch El (ft)	648.50	Shear (lb/sq ft)		0.31
Alpha	1.00	Stream Power (lb/ft s)	173.00	-12.70
28.50				
Frctn Loss (ft)	0.30	Cum Volume (acre-ft)		0.62
C & E Loss (ft)	0.00	Cum SA (acres)		0.25

Note: Multiple critical depths were found at this location. The critical depth with the lowest, valid, energy was used.

CROSS SECTION OUTPUT Profile #PF 18

		Element	Left OB	Channel
E.G. Elev (ft)	653.15			
Right OB				
Vel Head (ft)	0.28	wt. n-Val.		0.030
W.S. Elev (ft)	652.87	Reach Len. (ft)	148.00	150.00
142.00				
Crit w.s. (ft)	651.35	Flow Area (sq ft)		70.90
E.G. slope (ft/ft)	0.001954	Area (sq ft)		70.90

westTribClow.rep

Q Total (cfs)	300.00	Flow (cfs)		300.00
Top width (ft)	24.28	Top width (ft)		24.28
Vel Total (ft/s)	4.23	Avg. Vel. (ft/s)		4.23
Max Chl Dpth (ft)	4.37	Hydr. Depth (ft)		2.92
Conv. Total (cfs)	6786.4	Conv. (cfs)		6786.4
Length wtd. (ft)	150.00	wetted Per. (ft)		26.39
Min Ch El (ft)	648.50	Shear (lb/sq ft)		0.33
Alpha	1.00	Stream Power (lb/ft s)	173.00	-12.70
28.50				
Frctn Loss (ft)	0.30	Cum Volume (acre-ft)		0.66
C & E Loss (ft)	0.00	Cum SA (acres)		0.25

Note: Multiple critical depths were found at this location. The critical depth with the lowest, valid, energy was used.

CROSS SECTION OUTPUT Profile #PF 19

E.G. Elev (ft)	653.32	Element	Left OB	Channel
Right OB				
Vel Head (ft)	0.29	wt. n-val.	0.000	0.030
0.000				
W.S. Elev (ft)	653.03	Reach Len. (ft)	148.00	150.00
142.00				
Crit w.s. (ft)	651.47	Flow Area (sq ft)	0.00	74.81
0.00				
E.G. Slope (ft/ft)	0.001965	Area (sq ft)	0.00	74.81
0.00				
Q Total (cfs)	325.00	Flow (cfs)	0.00	325.00
0.00				
Top width (ft)	24.98	Top width (ft)	0.03	24.70
0.25				
Vel Total (ft/s)	4.34	Avg. Vel. (ft/s)	0.04	4.34
0.05				
Max Chl Dpth (ft)	4.53	Hydr. Depth (ft)	0.01	3.03
0.01				
Conv. Total (cfs)	7331.2	Conv. (cfs)	0.0	7331.2
0.0				
Length wtd. (ft)	150.00	wetted Per. (ft)	0.04	26.88
0.25				
Min Ch El (ft)	648.50	Shear (lb/sq ft)		0.34
Alpha	1.00	Stream Power (lb/ft s)	173.00	-12.70
28.50				
Frctn Loss (ft)	0.30	Cum Volume (acre-ft)	0.00	0.70
0.00				
C & E Loss (ft)	0.00	Cum SA (acres)	0.00	0.26
0.00				

Note: Multiple critical depths were found at this location. The critical depth with the lowest, valid, energy was used.

CROSS SECTION OUTPUT Profile #PF 20

E.G. Elev (ft)	653.49	Element	Left OB	Channel
Right OB				
Vel Head (ft)	0.31	wt. n-Val.	0.080	0.030
0.080				
W.S. Elev (ft)	653.18	Reach Len. (ft)	148.00	150.00
142.00				
Crit w.s. (ft)	651.60	Flow Area (sq ft)	0.02	78.50
0.14				
E.G. Slope (ft/ft)	0.001941	Area (sq ft)	0.02	78.50
0.14				
Q Total (cfs)	350.00	Flow (cfs)	0.00	349.97
0.02				
Top width (ft)	26.49	Top width (ft)	0.20	24.70
1.59				
Vel Total (ft/s)	4.45	Avg. Vel. (ft/s)	0.13	4.46
0.16				
Max Chl Dpth (ft)	4.68	Hydr. Depth (ft)	0.09	3.18
0.09				
Conv. Total (cfs)	7943.9	Conv. (cfs)	0.1	7943.4
0.5				
Length wtd. (ft)	150.00	wetted Per. (ft)	0.26	26.88
1.60				
Min Ch El (ft)	648.50	Shear (lb/sq ft)	0.01	0.35
0.01				
Alpha	1.00	Stream Power (lb/ft s)	173.00	-12.70
28.50				
Frctn Loss (ft)	0.31	Cum Volume (acre-ft)	0.00	0.74
0.00				
C & E Loss (ft)	0.00	Cum SA (acres)	0.00	0.26
0.00				

Note: Multiple critical depths were found at this location. The critical depth with the lowest, valid, energy was used.

CROSS SECTION OUTPUT Profile #PF 21

E.G. Elev (ft)	653.64	Element	Left OB	Channel
Right OB				
Vel Head (ft)	0.32	wt. n-Val.	0.080	0.030
0.080				
W.S. Elev (ft)	653.32	Reach Len. (ft)	148.00	150.00
142.00				
Crit w.s. (ft)	651.71	Flow Area (sq ft)	0.06	82.04
0.46				
E.G. Slope (ft/ft)	0.001922	Area (sq ft)	0.06	82.04
0.46				
Q Total (cfs)	375.00	Flow (cfs)	0.01	374.88
0.11				
Top width (ft)	27.94	Top width (ft)	0.36	24.70
2.89				
Vel Total (ft/s)	4.54	Avg. Vel. (ft/s)	0.20	4.57
0.24				
Max Chl Dpth (ft)	4.82	Hydr. Depth (ft)	0.16	3.32
0.16				

westTribClow.rep				
Conv. Total (cfs)	8553.1	Conv. (cfs)	0.3	8550.3
2.5				
Length wtd. (ft)	150.00	wetted Per. (ft)	0.48	26.88
2.90				
Min Ch El (ft)	648.50	Shear (lb/sq ft)	0.01	0.37
0.02				
Alpha	1.01	Stream Power (lb/ft s)	173.00	-12.70
28.50				
Frctn Loss (ft)	0.31	Cum Volume (acre-ft)	0.00	0.78
0.00				
C & E Loss (ft)	0.00	Cum SA (acres)	0.00	0.27
0.00				

Note: Multiple critical depths were found at this location. The critical depth with the lowest, valid, energy was used.

CROSS SECTION OUTPUT Profile #PF 22

Profile #PF 22				
E.G. Elev (ft)	653.80	Element	Left OB	Channel
Right OB				
Vel Head (ft)	0.34	wt. n-val.	0.080	0.030
0.080				
W.S. Elev (ft)	653.47	Reach Len. (ft)	148.00	150.00
142.00				
Crit w.s. (ft)	651.82	Flow Area (sq ft)	0.12	85.61
0.97				
E.G. Slope (ft/ft)	0.001896	Area (sq ft)	0.12	85.61
0.97				
Q Total (cfs)	400.00	Flow (cfs)	0.03	399.67
0.30				
Top width (ft)	29.40	Top width (ft)	0.52	24.70
4.18				
Vel Total (ft/s)	4.61	Avg. Vel. (ft/s)	0.25	4.67
0.30				
Max Chl Dpth (ft)	4.96	Hydr. Depth (ft)	0.23	3.47
0.23				
Conv. Total (cfs)	9186.3	Conv. (cfs)	0.7	9178.8
6.8				
Length wtd. (ft)	150.00	wetted Per. (ft)	0.70	26.88
4.21				
Min Ch El (ft)	648.50	Shear (lb/sq ft)	0.02	0.38
0.03				
Alpha	1.02	Stream Power (lb/ft s)	173.00	-12.70
28.50				
Frctn Loss (ft)	0.31	Cum Volume (acre-ft)	0.00	0.82
0.00				
C & E Loss (ft)	0.00	Cum SA (acres)	0.00	0.27
0.01				

Note: Multiple critical depths were found at this location. The critical depth with the lowest, valid, energy was used.

CROSS SECTION OUTPUT Profile #PF 23

Profile #PF 23				
E.G. Elev (ft)	653.96	Element	Left OB	Channel
Right OB				
Vel Head (ft)	0.35	wt. n-val.	0.080	0.030

westTribClow.rep

0.080				
W.S. Elev (ft)	653.60	Reach Len. (ft)	148.00	150.00
142.00				
Crit w.s. (ft)	651.92	Flow Area (sq ft)	0.20	89.01
1.63				
E.G. Slope (ft/ft)	0.001877	Area (sq ft)	0.20	89.01
1.63				
Q Total (cfs)	425.00	Flow (cfs)	0.06	424.35
0.59				
Top Width (ft)	30.79	Top width (ft)	0.67	24.70
5.42				
Vel Total (ft/s)	4.68	Avg. Vel. (ft/s)	0.30	4.77
0.36				
Max Chl Dpth (ft)	5.10	Hydr. Depth (ft)	0.30	3.60
0.30				
Conv. Total (cfs)	9809.6	Conv. (cfs)	1.4	9794.6
13.6				
Length wtd. (ft)	149.99	wetted Per. (ft)	0.90	26.88
5.46				
Min Ch El (ft)	648.50	Shear (lb/sq ft)	0.03	0.39
0.04				
Alpha	1.04	Stream Power (lb/ft s)	173.00	-12.70
28.50				
Frctn Loss (ft)	0.31	Cum Volume (acre-ft)	0.00	0.85
0.00				
C & E Loss (ft)	0.00	Cum SA (acres)	0.00	0.28
0.01				

Note: Multiple critical depths were found at this location. The critical depth with the lowest, valid, energy was used.

CROSS SECTION OUTPUT Profile #PF 24

E.G. Elev (ft)	654.10	Element	Left OB	Channel
Right OB				
Vel Head (ft)	0.37	wt. n-val.	0.080	0.030
0.080				
W.S. Elev (ft)	653.73	Reach Len. (ft)	148.00	150.00
142.00				
Crit w.s. (ft)	652.02	Flow Area (sq ft)	0.30	92.24
2.42				
E.G. Slope (ft/ft)	0.001865	Area (sq ft)	0.30	92.24
2.42				
Q Total (cfs)	450.00	Flow (cfs)	0.10	448.91
0.99				
Top Width (ft)	32.12	Top width (ft)	0.81	24.70
6.60				
Vel Total (ft/s)	4.74	Avg. Vel. (ft/s)	0.34	4.87
0.41				
Max Chl Dpth (ft)	5.23	Hydr. Depth (ft)	0.37	3.73
0.37				
Conv. Total (cfs)	10419.5	Conv. (cfs)	2.3	10394.3
22.9				
Length wtd. (ft)	149.99	wetted Per. (ft)	1.10	26.88
6.64				
Min Ch El (ft)	648.50	Shear (lb/sq ft)	0.03	0.40
0.04				
Alpha	1.05	Stream Power (lb/ft s)	173.00	-12.70
28.50				
Frctn Loss (ft)	0.31	Cum Volume (acre-ft)	0.15	0.89

westTribClow.rep

0.00				
C & E Loss (ft)	0.00	Cum SA (acres)	0.35	0.28
0.01				

Note: Multiple critical depths were found at this location. The critical depth with the lowest, valid, energy was used.

CROSS SECTION OUTPUT Profile #PF 25

E.G. Elev (ft)	654.20	Element	Left OB	Channel
Right OB				
Vel Head (ft)	0.39	wt. n-Val.	0.080	0.030
0.080				
W.S. Elev (ft)	653.81	Reach Len. (ft)	148.00	150.00
142.00				
Crit w.s. (ft)	652.12	Flow Area (sq ft)	0.36	94.09
2.94				
E.G. Slope (ft/ft)	0.001943	Area (sq ft)	0.36	94.09
2.94				
Q Total (cfs)	475.00	Flow (cfs)	0.13	473.56
1.31				
Top width (ft)	32.87	Top width (ft)	0.90	24.70
7.28				
Vel Total (ft/s)	4.88	Avg. Vel. (ft/s)	0.37	5.03
0.45				
Max Chl Dpth (ft)	5.31	Hydr. Depth (ft)	0.40	3.81
0.40				
Conv. Total (cfs)	10777.3	Conv. (cfs)	3.0	10744.6
29.7				
Length wtd. (ft)	149.99	wetted Per. (ft)	1.21	26.88
7.32				
Min Ch El (ft)	648.50	Shear (lb/sq ft)	0.04	0.42
0.05				
Alpha	1.06	Stream Power (lb/ft s)	173.00	-12.70
28.50				
Frctn Loss (ft)	0.32	Cum volume (acre-ft)	0.26	0.92
0.02				
C & E Loss (ft)	0.00	Cum SA (acres)	0.58	0.29
0.15				

Note: Multiple critical depths were found at this location. The critical depth with the lowest, valid, energy was used.

CROSS SECTION OUTPUT Profile #PF 26

E.G. Elev (ft)	654.29	Element	Left OB	Channel
Right OB				
Vel Head (ft)	0.42	wt. n-Val.	0.080	0.030
0.080				
W.S. Elev (ft)	653.87	Reach Len. (ft)	148.00	150.00
142.00				
Crit w.s. (ft)	652.21	Flow Area (sq ft)	0.42	95.50
3.37				
E.G. Slope (ft/ft)	0.002047	Area (sq ft)	0.42	95.50
3.37				
Q Total (cfs)	500.00	Flow (cfs)	0.16	498.22
1.61				

westTribClow.rep				
Top width (ft)	33.45	Top width (ft)	0.96	24.70
7.79				
Vel Total (ft/s)	5.04	Avg. Vel. (ft/s)	0.39	5.22
0.48				
Max Chl Dpth (ft)	5.37	Hydr. Depth (ft)	0.43	3.87
0.43				
Conv. Total (cfs)	11052.0	Conv. (cfs)	3.6	11012.7
35.6				
Length wtd. (ft)	149.79	wetted Per. (ft)	1.29	26.88
7.84				
Min Ch El (ft)	648.50	Shear (lb/sq ft)	0.04	0.45
0.05				
Alpha	1.07	Stream Power (lb/ft s)	173.00	-12.70
28.50				
Frctn Loss (ft)	0.31	Cum Volume (acre-ft)	0.35	0.96
0.19				
C & E Loss (ft)	0.02	Cum SA (acres)	0.66	0.29
0.54				

Note: Multiple critical depths were found at this location. The critical depth with the lowest, valid, energy was used.

CROSS SECTION OUTPUT Profile #PF 27

E.G. Elev (ft)	654.38	Element	Left OB	Channel
Right OB				
Vel Head (ft)	0.45	wt. n-val.	0.080	0.030
0.080				
W.S. Elev (ft)	653.93	Reach Len. (ft)	148.00	150.00
142.00				
Crit w.s. (ft)	652.31	Flow Area (sq ft)	0.48	97.19
3.92				
E.G. Slope (ft/ft)	0.002125	Area (sq ft)	74.76	97.19
3.92				
Q Total (cfs)	525.00	Flow (cfs)	0.21	522.78
2.01				
Top Width (ft)	236.84	Top Width (ft)	203.73	24.70
8.40				
Vel Total (ft/s)	5.17	Avg. Vel. (ft/s)	0.43	5.38
0.51				
Max Chl Dpth (ft)	5.43	Hydr. Depth (ft)	0.48	3.93
0.47				
Conv. Total (cfs)	11388.5	Conv. (cfs)	4.5	11340.3
43.7				
Length wtd. (ft)	149.76	wetted Per. (ft)	1.35	26.88
8.46				
Min Ch El (ft)	648.50	Shear (lb/sq ft)	0.05	0.48
0.06				
Alpha	1.08	Stream Power (lb/ft s)	173.00	-12.70
28.50				
Frctn Loss (ft)	0.32	Cum Volume (acre-ft)	0.61	0.99
0.24				
C & E Loss (ft)	0.02	Cum SA (acres)	1.49	0.29
0.60				

Note: Multiple critical depths were found at this location. The critical depth with the lowest, valid, energy was used.

CROSS SECTION OUTPUT Profile #PF 28

E.G. Elev (ft)	654.41	Element	Left OB	Channel
Right OB				
Vel Head (ft)	0.36	wt. n-val.	0.080	0.030
0.080				
W.S. Elev (ft)	654.05	Reach Len. (ft)	148.00	150.00
142.00				
Crit w.s. (ft)	652.40	Flow Area (sq ft)	0.60	99.97
57.47				
E.G. Slope (ft/ft)	0.001805	Area (sq ft)	98.16	99.97
106.30				
Q Total (cfs)	550.00	Flow (cfs)	0.27	505.03
44.69				
Top Width (ft)	380.36	Top width (ft)	209.30	24.70
146.36				
Vel Total (ft/s)	3.48	Avg. Vel. (ft/s)	0.46	5.05
0.78				
Max Chl Dpth (ft)	5.55	Hydr. Depth (ft)	0.60	4.05
0.95				
Conv. Total (cfs)	12945.0	Conv. (cfs)	6.4	11886.7
1051.9				
Length wtd. (ft)	149.42	wetted Per. (ft)	1.35	26.88
60.53				
Min Ch El (ft)	648.50	Shear (lb/sq ft)	0.05	0.42
0.11				
Alpha	1.94	Stream Power (lb/ft s)	173.00	-12.70
28.50				
Frctn Loss (ft)	0.30	Cum Volume (acre-ft)	0.77	1.02
0.46				
C & E Loss (ft)	0.00	Cum SA (acres)	1.66	0.29
0.86				

Warning: Multiple water surfaces were found that could balance the energy equation. The program selected the water surface whose main channel velocity head was the closest to the previously computed cross section.

Warning: Divided flow computed for this cross-section.

Warning: The cross-section end points had to be extended vertically for the computed water surface.

Note: Multiple critical depths were found at this location. The critical depth with the lowest, valid, energy was used.

CROSS SECTION OUTPUT Profile #PF 29

E.G. Elev (ft)	654.49	Element	Left OB	Channel
Right OB				
Vel Head (ft)	0.38	wt. n-val.	0.080	0.030
0.080				
W.S. Elev (ft)	654.11	Reach Len. (ft)	148.00	150.00
142.00				
Crit w.s. (ft)	652.49	Flow Area (sq ft)	0.66	101.43
61.03				
E.G. Slope (ft/ft)	0.001858	Area (sq ft)	110.46	101.43
114.91				
Q Total (cfs)	575.00	Flow (cfs)	0.32	524.87
49.81				
Top Width (ft)	380.82	Top width (ft)	209.30	24.70
146.82				

Vel Total (ft/s)	3.53	Avg. Vel. (ft/s)	0.50	5.17
0.82				
Max Chl Dpth (ft)	5.61	Hydr. Depth (ft)	0.66	4.11
1.00				
Conv. Total (cfs)	13338.7	Conv. (cfs)	7.5	12175.7
1155.4				
Length wtd. (ft)	149.38	wetted Per. (ft)	1.35	26.88
61.00				
Min Ch El (ft)	648.50	Shear (lb/sq ft)	0.06	0.44
0.12				
Alpha	1.97	Stream Power (lb/ft s)	173.00	-12.70
28.50				
Frctn Loss (ft)	0.31	Cum volume (acre-ft)	0.91	1.03
0.58				
C & E Loss (ft)	0.00	Cum SA (acres)	1.74	0.30
1.12				

Warning: Divided flow computed for this cross-section.
 Warning: The cross-section end points had to be extended vertically for the computed water surface.
 Note: Multiple critical depths were found at this location. The critical depth with the lowest, valid, energy was used.

CROSS SECTION OUTPUT Profile #PF 30

E.G. Elev (ft)	654.56	Element	Left OB	Channel
Right OB				
Vel Head (ft)	0.40	wt. n-val.	0.080	0.030
0.080				
W.S. Elev (ft)	654.16	Reach Len. (ft)	148.00	150.00
142.00				
Crit w.s. (ft)	652.58	Flow Area (sq ft)	0.71	102.84
64.51				
E.G. slope (ft/ft)	0.001910	Area (sq ft)	122.41	102.84
123.30				
Q Total (cfs)	600.00	Flow (cfs)	0.38	544.55
55.07				
Top width (ft)	381.26	Top width (ft)	209.30	24.70
147.26				
Vel Total (ft/s)	3.57	Avg. Vel. (ft/s)	0.53	5.30
0.85				
Max Chl Dpth (ft)	5.66	Hydr. Depth (ft)	0.71	4.16
1.05				
Conv. Total (cfs)	13727.7	Conv. (cfs)	8.7	12459.1
1259.9				
Length wtd. (ft)	149.32	wetted Per. (ft)	1.35	26.88
61.46				
Min Ch El (ft)	648.50	Shear (lb/sq ft)	0.06	0.46
0.13				
Alpha	2.00	Stream Power (lb/ft s)	173.00	-12.70
28.50				
Frctn Loss (ft)	0.31	Cum volume (acre-ft)	1.07	1.06
0.67				
C & E Loss (ft)	0.00	Cum SA (acres)	1.80	0.30
1.19				

Warning: Divided flow computed for this cross-section.
 Warning: The cross-section end points had to be extended vertically for the computed water surface.
 Page 138

WestTribClow.rep

water surface.

Note: Multiple critical depths were found at this location. The critical depth with the lowest, valid, energy was used.

CROSS SECTION

RIVER: WestTribClow
 REACH: WestTribClow RS: 1350

INPUT

Description: Sta 13+50

Station Elevation Data

Sta	Elev	Sta	Elev	Sta	Elev	Sta	Elev	Sta	Elev
-172.5	654	-156	653.8	-108	653.2	-97.5	653	-84.5	652.7
-57	652.9	-31	653	-17	653.4	-15	653	-13	652
-11	651	-9	650	-5	649	0	648.2	4	648.1
5.5	649	6.5	650	8	651	9	652	10.5	653
11	653.4	26.5	653	41	652.6	61	653	71.5	653.2
113.5	653.7	147.5	654						

Manning's n Values

Sta	n Val	Sta	n Val	Sta	n Val
-172.5	.08	-17	.03	11	.08

Bank Sta: Left Right Lengths: Left Channel Right Coeff Contr. Expan.
 -17 11 134 150 128 .1 .3

Ineffective Flow num= 2
 Sta L Sta R Elev Permanent
 -172.5 -23 658.1 F
 125 147.5 658.6 F

Left Levee Station= -17 Elevation= 653.4
 Right Levee Station= 11 Elevation= 653.5

CROSS SECTION OUTPUT Profile #PF 1

E.G. Elev (ft)	649.24	Element	Left OB	Channel
Right OB Vel Head (ft)	0.02	wt. n-val.		0.030
W.S. Elev (ft)	649.22	Reach Len. (ft)	134.00	150.00
128.00 Crit w.s. (ft)	648.65	Flow Area (sq ft)		8.54
E.G. slope (ft/ft)	0.000883	Area (sq ft)		8.54
Q Total (cfs)	10.00	Flow (cfs)		10.00
Top width (ft)	11.62	Top width (ft)		11.62
vel Total (ft/s)	1.17	Avg. vel. (ft/s)		1.17
Max chl Dpth (ft)	1.12	Hydr. Depth (ft)		0.74
Conv. Total (cfs)	336.5	Conv. (cfs)		336.5
Length wtd. (ft)	150.00	wetted Per. (ft)		12.05
Min ch El (ft)	648.10	shear (lb/sq ft)		0.04
Alpha	1.00	Stream Power (lb/ft s)	147.50	-17.00
11.00				

Frctn Loss (ft)	0.28	westTribCflow.rep Cum Volume (acre-ft)	0.04
C & E Loss (ft)	0.01	Cum SA (acres)	0.07

Warning: The conveyance ratio (upstream conveyance divided by downstream conveyance) is less than 0.7 or greater than 1.4.

This may indicate the need for additional cross sections.

Note: Multiple critical depths were found at this location. The critical depth with the lowest, valid, energy was used.

CROSS SECTION OUTPUT Profile #PF 2

E.G. Elev (ft)	649.64	Element	Left OB	Channel
Right OB Vel Head (ft)	0.04	wt. n-val.		0.030
W.S. Elev (ft)	649.60	Reach Len. (ft)	134.00	150.00
128.00 Crit w.s. (ft)	648.88	Flow Area (sq ft)		13.31
E.G. slope (ft/ft)	0.000999	Area (sq ft)		13.31
Q Total (cfs)	20.00	Flow (cfs)		20.00
Top width (ft)	13.51	Top width (ft)		13.51
Vel Total (ft/s)	1.50	Avg. vel. (ft/s)		1.50
Max chl Dpth (ft)	1.50	Hydr. Depth (ft)		0.98
Conv. Total (cfs)	632.7	Conv. (cfs)		632.7
Length wtd. (ft)	150.00	wetted Per. (ft)		14.15
Min Ch El (ft)	648.10	Shear (lb/sq ft)		0.06
Alpha	1.00	Stream Power (lb/ft s)	147.50	-17.00
11.00 Frctn Loss (ft)	0.31	Cum volume (acre-ft)		0.06
C & E Loss (ft)	0.01	Cum SA (acres)		0.08

Warning: The conveyance ratio (upstream conveyance divided by downstream conveyance) is less than 0.7 or greater than 1.4.

This may indicate the need for additional cross sections.

Note: Multiple critical depths were found at this location. The critical depth with the lowest, valid, energy was used.

CROSS SECTION OUTPUT Profile #PF 3

E.G. Elev (ft)	649.93	Element	Left OB	Channel
Right OB Vel Head (ft)	0.05	wt. n-val.		0.030
W.S. Elev (ft)	649.88	Reach Len. (ft)	134.00	150.00

westTribClow.rep

128.00				
Crit W.S. (ft)	649.06	Flow Area (sq ft)		17.22
E.G. Slope (ft/ft)	0.001091	Area (sq ft)		17.22
Q Total (cfs)	30.00	Flow (cfs)		30.00
Top Width (ft)	14.89	Top Width (ft)		14.89
Vel Total (ft/s)	1.74	Avg. Vel. (ft/s)		1.74
Max Chl Dpth (ft)	1.78	Hydr. Depth (ft)		1.16
Conv. Total (cfs)	908.3	Conv. (cfs)		908.3
Length Wtd. (ft)	150.00	wetted Per. (ft)		15.68
Min Ch El (ft)	648.10	Shear (lb/sq ft)		0.07
Alpha	1.00	Stream Power (lb/ft s)	147.50	-17.00
11.00				
Frctn Loss (ft)	0.33	Cum Volume (acre-ft)		0.08
C & E Loss (ft)	0.01	Cum SA (acres)		0.09

Warning: The conveyance ratio (upstream conveyance divided by downstream conveyance) is less than 0.7 or greater than 1.4.

This may indicate the need for additional cross sections.

Note: Multiple critical depths were found at this location. The critical depth with the lowest, valid, energy was used.

CROSS SECTION OUTPUT Profile #PF 4

E.G. Elev (ft)	650.15	Element	Left OB	Channel
Right OB				
Vel Head (ft)	0.06	wt. n-val.		0.030
W.S. Elev (ft)	650.10	Reach Len. (ft)	134.00	150.00
128.00				
Crit W.S. (ft)	649.20	Flow Area (sq ft)		20.57
E.G. Slope (ft/ft)	0.001171	Area (sq ft)		20.57
Q Total (cfs)	40.00	Flow (cfs)		40.00
Top Width (ft)	15.83	Top Width (ft)		15.83
Vel Total (ft/s)	1.94	Avg. Vel. (ft/s)		1.94
Max Chl Dpth (ft)	2.00	Hydr. Depth (ft)		1.30
Conv. Total (cfs)	1168.8	Conv. (cfs)		1168.8
Length Wtd. (ft)	150.00	wetted Per. (ft)		16.74
Min Ch El (ft)	648.10	Shear (lb/sq ft)		0.09
Alpha	1.00	Stream Power (lb/ft s)	147.50	-17.00
11.00				

Frctn Loss (ft)	0.35	westTribCflow.rep Cum Volume (acre-ft)	0.10
C & E Loss (ft)	0.01	Cum SA (acres)	0.10

Warning: The conveyance ratio (upstream conveyance divided by downstream conveyance) is less than 0.7 or greater than 1.4.

This may indicate the need for additional cross sections.

Note: Multiple critical depths were found at this location. The critical depth with the lowest, valid, energy was used.

CROSS SECTION OUTPUT Profile #PF 5

E.G. Elev (ft)	650.35	Element	Left OB	Channel
Right OB Vel Head (ft)	0.07	wt. n-val.		0.030
W.S. Elev (ft)	650.28	Reach Len. (ft)	134.00	150.00
128.00 Crit w.s. (ft)	649.33	Flow Area (sq ft)		23.52
E.G. slope (ft/ft)	0.001240	Area (sq ft)		23.52
Q Total (cfs)	50.00	Flow (cfs)		50.00
Top width (ft)	16.47	Top width (ft)		16.47
Vel Total (ft/s)	2.13	Avg. vel. (ft/s)		2.13
Max chl Dpth (ft)	2.18	Hydr. Depth (ft)		1.43
Conv. Total (cfs)	1419.9	Conv. (cfs)		1419.9
Length wtd. (ft)	150.00	wetted Per. (ft)		17.47
Min ch El (ft)	648.10	Shear (lb/sq ft)		0.10
Alpha	1.00	Stream Power (lb/ft s)	147.50	-17.00
11.00 Frctn Loss (ft)	0.36	Cum volume (acre-ft)		0.12
C & E Loss (ft)	0.02	Cum SA (acres)		0.11

Warning: The conveyance ratio (upstream conveyance divided by downstream conveyance) is less than 0.7 or greater than 1.4.

This may indicate the need for additional cross sections.

Note: Multiple critical depths were found at this location. The critical depth with the lowest, valid, energy was used.

CROSS SECTION OUTPUT Profile #PF 6

E.G. Elev (ft)	650.52	Element	Left OB	Channel
Right OB Vel Head (ft)	0.08	wt. n-val.		0.030
W.S. Elev (ft)	650.44	Reach Len. (ft)	134.00	150.00

westTribClow.rep

128.00				
Crit W.S. (ft)	649.44	Flow Area (sq ft)		26.26
E.G. Slope (ft/ft)	0.001299	Area (sq ft)		26.26
Q Total (cfs)	60.00	Flow (cfs)		60.00
Top Width (ft)	17.04	Top Width (ft)		17.04
Vel Total (ft/s)	2.29	Avg. Vel. (ft/s)		2.29
Max Chl Dpth (ft)	2.34	Hydr. Depth (ft)		1.54
Conv. Total (cfs)	1664.5	Conv. (cfs)		1664.5
Length Wtd. (ft)	150.00	wetted Per. (ft)		18.13
Min Ch El (ft)	648.10	Shear (lb/sq ft)		0.12
Alpha	1.00	Stream Power (lb/ft s)	147.50	-17.00
11.00				
Frctn Loss (ft)	0.37	Cum Volume (acre-ft)		0.14
C & E Loss (ft)	0.02	Cum SA (acres)		0.12

Warning: The conveyance ratio (upstream conveyance divided by downstream conveyance) is less than 0.7 or greater than 1.4.

This may indicate the need for additional cross sections.

Note: Multiple critical depths were found at this location. The critical depth with the lowest, valid, energy was used.

CROSS SECTION OUTPUT Profile #PF 7

E.G. Elev (ft)	650.68	Element	Left OB	Channel
Right OB				
Vel Head (ft)	0.09	wt. n-val.		0.030
W.S. Elev (ft)	650.58	Reach Len. (ft)	134.00	150.00
128.00				
Crit W.S. (ft)	649.55	Flow Area (sq ft)		28.72
E.G. Slope (ft/ft)	0.001368	Area (sq ft)		28.72
Q Total (cfs)	70.00	Flow (cfs)		70.00
Top Width (ft)	17.54	Top Width (ft)		17.54
Vel Total (ft/s)	2.44	Avg. Vel. (ft/s)		2.44
Max Chl Dpth (ft)	2.48	Hydr. Depth (ft)		1.64
Conv. Total (cfs)	1892.5	Conv. (cfs)		1892.5
Length Wtd. (ft)	150.00	wetted Per. (ft)		18.71
Min Ch El (ft)	648.10	Shear (lb/sq ft)		0.13
Alpha	1.00	Stream Power (lb/ft s)	147.50	-17.00
11.00				

Frctn Loss (ft)	0.38	westTribClow.rep Cum Volume (acre-ft)	0.15
C & E Loss (ft)	0.02	Cum SA (acres)	0.12

Warning: The conveyance ratio (upstream conveyance divided by downstream conveyance) is less than 0.7 or greater than 1.4.

This may indicate the need for additional cross sections.

Note: Multiple critical depths were found at this location. The critical depth with the lowest, valid, energy was used.

CROSS SECTION OUTPUT Profile #PF 8

E.G. Elev (ft)	650.82	Element	Left OB	Channel
Right OB Vel Head (ft)	0.10	wt. n-val.		0.030
W.S. Elev (ft)	650.71	Reach Len. (ft)	134.00	150.00
128.00 Crit w.s. (ft)	649.65	Flow Area (sq ft)		30.99
E.G. Slope (ft/ft)	0.001437	Area (sq ft)		30.99
Q Total (cfs)	80.00	Flow (cfs)		80.00
Top width (ft)	17.99	Top width (ft)		17.99
Vel Total (ft/s)	2.58	Avg. vel. (ft/s)		2.58
Max chl Dpth (ft)	2.61	Hydr. Depth (ft)		1.72
Conv. Total (cfs)	2110.1	Conv. (cfs)		2110.1
Length wtd. (ft)	150.00	wetted Per. (ft)		19.23
Min Ch El (ft)	648.10	Shear (lb/sq ft)		0.14
Alpha	1.00	Stream Power (lb/ft s)	147.50	-17.00
11.00 Frctn Loss (ft)	0.39	Cum volume (acre-ft)		0.17
C & E Loss (ft)	0.02	Cum SA (acres)		0.12

Warning: The conveyance ratio (upstream conveyance divided by downstream conveyance) is less than 0.7 or greater than 1.4.

This may indicate the need for additional cross sections.

Note: Multiple critical depths were found at this location. The critical depth with the lowest, valid, energy was used.

CROSS SECTION OUTPUT Profile #PF 9

E.G. Elev (ft)	650.95	Element	Left OB	Channel
Right OB Vel Head (ft)	0.11	wt. n-val.		0.030
W.S. Elev (ft)	650.83	Reach Len. (ft)	134.00	150.00

westTribClow.rep

128.00				
Crit W.S. (ft)	649.75	Flow Area (sq ft)		33.19
E.G. Slope (ft/ft)	0.001497	Area (sq ft)		33.19
Q Total (cfs)	90.00	Flow (cfs)		90.00
Top Width (ft)	18.41	Top Width (ft)		18.41
Vel Total (ft/s)	2.71	Avg. Vel. (ft/s)		2.71
Max Chl Dpth (ft)	2.73	Hydr. Depth (ft)		1.80
Conv. Total (cfs)	2326.3	Conv. (cfs)		2326.3
Length Wtd. (ft)	150.00	wetted Per. (ft)		19.71
Min Ch El (ft)	648.10	Shear (lb/sq ft)		0.16
Alpha	1.00	Stream Power (lb/ft s)	147.50	-17.00
11.00				
Frctn Loss (ft)	0.39	Cum Volume (acre-ft)		0.18
C & E Loss (ft)	0.02	Cum SA (acres)		0.13

Warning: The conveyance ratio (upstream conveyance divided by downstream conveyance) is less than 0.7 or greater than 1.4.

This may indicate the need for additional cross sections.

Note: Multiple critical depths were found at this location. The critical depth with the lowest, valid, energy was used.

CROSS SECTION OUTPUT Profile #PF 10

E.G. Elev (ft)	651.07	Element	Left OB	Channel
Right OB				
Vel Head (ft)	0.12	wt. n-val.		0.030
W.S. Elev (ft)	650.95	Reach Len. (ft)	134.00	150.00
128.00				
Crit W.S. (ft)	649.84	Flow Area (sq ft)		35.31
E.G. Slope (ft/ft)	0.001550	Area (sq ft)		35.31
Q Total (cfs)	100.00	Flow (cfs)		100.00
Top Width (ft)	18.81	Top Width (ft)		18.81
Vel Total (ft/s)	2.83	Avg. Vel. (ft/s)		2.83
Max Chl Dpth (ft)	2.85	Hydr. Depth (ft)		1.88
Conv. Total (cfs)	2540.0	Conv. (cfs)		2540.0
Length Wtd. (ft)	150.00	wetted Per. (ft)		20.17
Min Ch El (ft)	648.10	Shear (lb/sq ft)		0.17
Alpha	1.00	Stream Power (lb/ft s)	147.50	-17.00
11.00				

Frctn Loss (ft)	0.40	westTribCflow.rep Cum Volume (acre-ft)	0.19
C & E Loss (ft)	0.02	Cum SA (acres)	0.13

Warning: The conveyance ratio (upstream conveyance divided by downstream conveyance) is less than 0.7 or greater than 1.4.

This may indicate the need for additional cross sections.

Note: Multiple critical depths were found at this location. The critical depth with the lowest, valid, energy was used.

CROSS SECTION OUTPUT Profile #PF 11

E.G. Elev (ft)	651.36	Element	Left OB	Channel
Right OB Vel Head (ft)	0.15	wt. n-val.		0.030
W.S. Elev (ft)	651.21	Reach Len. (ft)	134.00	150.00
128.00 Crit w.s. (ft)	650.04	Flow Area (sq ft)		40.33
E.G. Slope (ft/ft)	0.001656	Area (sq ft)		40.33
Q Total (cfs)	125.00	Flow (cfs)		125.00
Top width (ft)	19.62	Top width (ft)		19.62
Vel Total (ft/s)	3.10	Avg. vel. (ft/s)		3.10
Max Chl Dpth (ft)	3.11	Hydr. Depth (ft)		2.06
Conv. Total (cfs)	3072.0	Conv. (cfs)		3072.0
Length wtd. (ft)	150.00	wetted Per. (ft)		21.15
Min Ch El (ft)	648.10	Shear (lb/sq ft)		0.20
Alpha	1.00	Stream Power (lb/ft s)	147.50	-17.00
11.00 Frctn Loss (ft)	0.41	Cum volume (acre-ft)		0.23
C & E Loss (ft)	0.02	Cum SA (acres)		0.14

Warning: The conveyance ratio (upstream conveyance divided by downstream conveyance) is less than 0.7 or greater than 1.4.

This may indicate the need for additional cross sections.

Note: Multiple critical depths were found at this location. The critical depth with the lowest, valid, energy was used.

CROSS SECTION OUTPUT Profile #PF 12

E.G. Elev (ft)	651.62	Element	Left OB	Channel
Right OB Vel Head (ft)	0.17	wt. n-val.		0.030
W.S. Elev (ft)	651.44	Reach Len. (ft)	134.00	150.00

westTribClow.rep

128.00				
Crit w.s. (ft)	650.21	Flow Area (sq ft)		45.03
E.G. Slope (ft/ft)	0.001741	Area (sq ft)		45.03
Q Total (cfs)	150.00	Flow (cfs)		150.00
Top width (ft)	20.33	Top width (ft)		20.33
Vel Total (ft/s)	3.33	Avg. Vel. (ft/s)		3.33
Max Chl Dpth (ft)	3.34	Hydr. Depth (ft)		2.22
Conv. Total (cfs)	3595.0	Conv. (cfs)		3595.0
Length wtd. (ft)	150.00	wetted Per. (ft)		22.01
Min Ch El (ft)	648.10	Shear (lb/sq ft)		0.22
Alpha	1.00	Stream Power (lb/ft s)	147.50	-17.00
11.00				
Frctn Loss (ft)	0.42	Cum volume (acre-ft)		0.26
C & E Loss (ft)	0.02	Cum SA (acres)		0.14

Warning: The conveyance ratio (upstream conveyance divided by downstream conveyance) is less than 0.7 or greater than 1.4.

This may indicate the need for additional cross sections.

Note: Multiple critical depths were found at this location. The critical depth with the lowest, valid, energy was used.

CROSS SECTION OUTPUT Profile #PF 13

E.G. Elev (ft)	651.85	Element	Left OB	Channel
Right OB				
Vel Head (ft)	0.19	wt. n-val.		0.030
W.S. Elev (ft)	651.66	Reach Len. (ft)	134.00	150.00
128.00				
Crit w.s. (ft)	650.38	Flow Area (sq ft)		49.49
E.G. Slope (ft/ft)	0.001813	Area (sq ft)		49.49
Q Total (cfs)	175.00	Flow (cfs)		175.00
Top width (ft)	20.98	Top width (ft)		20.98
Vel Total (ft/s)	3.54	Avg. Vel. (ft/s)		3.54
Max Chl Dpth (ft)	3.56	Hydr. Depth (ft)		2.36
Conv. Total (cfs)	4109.6	Conv. (cfs)		4109.6
Length wtd. (ft)	150.00	wetted Per. (ft)		22.79
Min Ch El (ft)	648.10	Shear (lb/sq ft)		0.25
Alpha	1.00	Stream Power (lb/ft s)	147.50	-17.00
11.00				

Frctn Loss (ft)	0.42	westTribCflow.rep Cum Volume (acre-ft)	0.29
C & E Loss (ft)	0.02	Cum SA (acres)	0.15

Warning: The conveyance ratio (upstream conveyance divided by downstream conveyance) is less than 0.7 or greater than 1.4.

This may indicate the need for additional cross sections.

Note: Multiple critical depths were found at this location. The critical depth with the lowest, valid, energy was used.

CROSS SECTION OUTPUT Profile #PF 14

E.G. Elev (ft)	652.07	Element	Left OB	Channel
Right OB Vel Head (ft)	0.22	wt. n-val.		0.030
W.S. Elev (ft)	651.86	Reach Len. (ft)	134.00	150.00
128.00 Crit w.s. (ft)	650.53	Flow Area (sq ft)		53.73
E.G. slope (ft/ft)	0.001877	Area (sq ft)		53.73
Q Total (cfs)	200.00	Flow (cfs)		200.00
Top width (ft)	21.57	Top width (ft)		21.57
Vel Total (ft/s)	3.72	Avg. vel. (ft/s)		3.72
Max chl Dpth (ft)	3.76	Hydr. Depth (ft)		2.49
Conv. Total (cfs)	4616.4	Conv. (cfs)		4616.4
Length wtd. (ft)	150.00	wetted Per. (ft)		23.52
Min Ch El (ft)	648.10	Shear (lb/sq ft)		0.27
Alpha	1.00	Stream Power (lb/ft s)	147.50	-17.00
11.00 Frctn Loss (ft)	0.43	Cum volume (acre-ft)		0.31
C & E Loss (ft)	0.02	Cum SA (acres)		0.15

Warning: The conveyance ratio (upstream conveyance divided by downstream conveyance) is less than 0.7 or greater than 1.4.

This may indicate the need for additional cross sections.

Note: Multiple critical depths were found at this location. The critical depth with the lowest, valid, energy was used.

CROSS SECTION OUTPUT Profile #PF 15

E.G. Elev (ft)	652.28	Element	Left OB	Channel
Right OB Vel Head (ft)	0.23	wt. n-val.		0.030
W.S. Elev (ft)	652.05	Reach Len. (ft)	134.00	150.00

westTribClow.rep

128.00				
Crit w.s. (ft)	650.68	Flow Area (sq ft)		57.84
E.G. Slope (ft/ft)	0.001933	Area (sq ft)		57.84
Q Total (cfs)	225.00	Flow (cfs)		225.00
Top width (ft)	22.16	Top width (ft)		22.16
Vel Total (ft/s)	3.89	Avg. Vel. (ft/s)		3.89
Max Chl Dpth (ft)	3.95	Hydr. Depth (ft)		2.61
Conv. Total (cfs)	5117.2	Conv. (cfs)		5117.2
Length wtd. (ft)	150.00	wetted Per. (ft)		24.23
Min Ch El (ft)	648.10	Shear (lb/sq ft)		0.29
Alpha	1.00	Stream Power (lb/ft s)	147.50	-17.00
11.00				
Frctn Loss (ft)	0.43	Cum volume (acre-ft)		0.34
C & E Loss (ft)	0.02	Cum SA (acres)		0.16

Warning: The conveyance ratio (upstream conveyance divided by downstream conveyance) is less than 0.7 or greater than 1.4.

This may indicate the need for additional cross sections.

Note: Multiple critical depths were found at this location. The critical depth with the lowest, valid, energy was used.

CROSS SECTION OUTPUT Profile #PF 16

E.G. Elev (ft)	652.48	Element	Left OB	Channel
Right OB				
Vel Head (ft)	0.25	wt. n-val.		0.030
W.S. Elev (ft)	652.22	Reach Len. (ft)	134.00	150.00
128.00				
Crit w.s. (ft)	650.82	Flow Area (sq ft)		61.84
E.G. Slope (ft/ft)	0.001985	Area (sq ft)		61.84
Q Total (cfs)	250.00	Flow (cfs)		250.00
Top width (ft)	22.78	Top width (ft)		22.78
Vel Total (ft/s)	4.04	Avg. Vel. (ft/s)		4.04
Max Chl Dpth (ft)	4.12	Hydr. Depth (ft)		2.71
Conv. Total (cfs)	5610.6	Conv. (cfs)		5610.6
Length wtd. (ft)	150.00	wetted Per. (ft)		24.95
Min Ch El (ft)	648.10	Shear (lb/sq ft)		0.31
Alpha	1.00	Stream Power (lb/ft s)	147.50	-17.00
11.00				

Frctn Loss (ft)	0.43	westTribClow.rep Cum Volume (acre-ft)	0.37
C & E Loss (ft)	0.02	Cum SA (acres)	0.16

Warning: The conveyance ratio (upstream conveyance divided by downstream conveyance) is less than 0.7 or greater than 1.4.

This may indicate the need for additional cross sections.

Note: Multiple critical depths were found at this location. The critical depth with the lowest, valid, energy was used.

CROSS SECTION OUTPUT Profile #PF 17

E.G. Elev (ft)	652.67	Element	Left OB	Channel
Right OB Vel Head (ft)	0.27	wt. n-val.		0.030
W.S. Elev (ft)	652.39	Reach Len. (ft)	134.00	150.00
128.00 Crit w.s. (ft)	650.94	Flow Area (sq ft)		65.75
E.G. slope (ft/ft)	0.002030	Area (sq ft)		65.75
Q Total (cfs)	275.00	Flow (cfs)		275.00
Top width (ft)	23.38	Top width (ft)		23.38
Vel Total (ft/s)	4.18	Avg. vel. (ft/s)		4.18
Max chl Dpth (ft)	4.29	Hydr. Depth (ft)		2.81
Conv. Total (cfs)	6103.0	Conv. (cfs)		6103.0
Length wtd. (ft)	150.00	wetted Per. (ft)		25.63
Min Ch El (ft)	648.10	Shear (lb/sq ft)		0.33
Alpha	1.00	Stream Power (lb/ft s)	147.50	-17.00
11.00 Frctn Loss (ft)	0.44	Cum volume (acre-ft)		0.40
C & E Loss (ft)	0.02	Cum SA (acres)		0.16

Warning: The conveyance ratio (upstream conveyance divided by downstream conveyance) is less than 0.7 or greater than 1.4.

This may indicate the need for additional cross sections.

Note: Multiple critical depths were found at this location. The critical depth with the lowest, valid, energy was used.

CROSS SECTION OUTPUT Profile #PF 18

E.G. Elev (ft)	652.84	Element	Left OB	Channel
Right OB Vel Head (ft)	0.29	wt. n-val.		0.030
W.S. Elev (ft)	652.55	Reach Len. (ft)	134.00	150.00

westTribClow.rep

128.00				
Crit W.S. (ft)	651.08	Flow Area (sq ft)		69.57
E.G. Slope (ft/ft)	0.002070	Area (sq ft)		69.57
Q Total (cfs)	300.00	Flow (cfs)		300.00
Top Width (ft)	23.94	Top Width (ft)		23.94
Vel Total (ft/s)	4.31	Avg. Vel. (ft/s)		4.31
Max Chl Dpth (ft)	4.45	Hydr. Depth (ft)		2.91
Conv. Total (cfs)	6593.7	Conv. (cfs)		6593.7
Length Wtd. (ft)	150.00	wetted Per. (ft)		26.28
Min Ch El (ft)	648.10	Shear (lb/sq ft)		0.34
Alpha	1.00	Stream Power (lb/ft s)	147.50	-17.00
11.00				
Frctn Loss (ft)	0.44	Cum Volume (acre-ft)		0.42
C & E Loss (ft)	0.02	Cum SA (acres)		0.17

Warning: The conveyance ratio (upstream conveyance divided by downstream conveyance) is less than 0.7 or greater than 1.4.

This may indicate the need for additional cross sections.

Note: Multiple critical depths were found at this location. The critical depth with the lowest, valid, energy was used.

CROSS SECTION OUTPUT Profile #PF 19

E.G. Elev (ft)	653.01	Element	Left OB	Channel
Right OB				
Vel Head (ft)	0.31	wt. n-val.		0.030
W.S. Elev (ft)	652.71	Reach Len. (ft)	134.00	150.00
128.00				
Crit W.S. (ft)	651.20	Flow Area (sq ft)		73.31
E.G. Slope (ft/ft)	0.002105	Area (sq ft)		73.31
Q Total (cfs)	325.00	Flow (cfs)		325.00
Top Width (ft)	24.48	Top Width (ft)		24.48
Vel Total (ft/s)	4.43	Avg. Vel. (ft/s)		4.43
Max Chl Dpth (ft)	4.61	Hydr. Depth (ft)		2.99
Conv. Total (cfs)	7084.2	Conv. (cfs)		7084.2
Length Wtd. (ft)	150.00	wetted Per. (ft)		26.91
Min Ch El (ft)	648.10	Shear (lb/sq ft)		0.36
Alpha	1.00	Stream Power (lb/ft s)	147.50	-17.00
11.00				

Frctn Loss (ft)	0.44	westTribClow.rep Cum Volume (acre-ft)	0.45
C & E Loss (ft)	0.02	Cum SA (acres)	0.17

Warning: The conveyance ratio (upstream conveyance divided by downstream conveyance) is less than 0.7 or greater than 1.4.

This may indicate the need for additional cross sections.

Note: Multiple critical depths were found at this location. The critical depth with the lowest, valid, energy was used.

CROSS SECTION OUTPUT Profile #PF 20

E.G. Elev (ft)	653.18	Element	Left OB	Channel
Right OB Vel Head (ft)	0.32	wt. n-val.		0.030
W.S. Elev (ft)	652.86	Reach Len. (ft)	134.00	150.00
128.00 Crit w.s. (ft)	651.31	Flow Area (sq ft)		77.00
E.G. slope (ft/ft)	0.002135	Area (sq ft)		77.00
Q Total (cfs)	350.00	Flow (cfs)		350.00
Top width (ft)	25.00	Top width (ft)		25.00
Vel Total (ft/s)	4.55	Avg. vel. (ft/s)		4.55
Max chl Dpth (ft)	4.76	Hydr. Depth (ft)		3.08
Conv. Total (cfs)	7574.8	Conv. (cfs)		7574.8
Length wtd. (ft)	150.00	wetted Per. (ft)		27.51
Min Ch El (ft)	648.10	Shear (lb/sq ft)		0.37
Alpha	1.00	Stream Power (lb/ft s)	147.50	-17.00
11.00 Frctn Loss (ft)	0.44	Cum volume (acre-ft)		0.47
C & E Loss (ft)	0.02	Cum SA (acres)		0.18

Warning: The conveyance ratio (upstream conveyance divided by downstream conveyance) is less than 0.7 or greater than 1.4.

This may indicate the need for additional cross sections.

Note: Multiple critical depths were found at this location. The critical depth with the lowest, valid, energy was used.

CROSS SECTION OUTPUT Profile #PF 21

E.G. Elev (ft)	653.34	Element	Left OB	Channel
Right OB Vel Head (ft)	0.34	wt. n-val.		0.030
W.S. Elev (ft)	653.00	Reach Len. (ft)	134.00	150.00

westTribClow.rep

128.00				
Crit W.S. (ft)	651.43	Flow Area (sq ft)		80.63
E.G. Slope (ft/ft)	0.002162	Area (sq ft)		80.63
Q Total (cfs)	375.00	Flow (cfs)		375.00
Top Width (ft)	25.51	Top Width (ft)		25.51
Vel Total (ft/s)	4.65	Avg. Vel. (ft/s)		4.65
Max Chl Dpth (ft)	4.90	Hydr. Depth (ft)		3.16
Conv. Total (cfs)	8065.2	Conv. (cfs)		8065.2
Length Wtd. (ft)	150.00	wetted Per. (ft)		28.09
Min Ch El (ft)	648.10	Shear (lb/sq ft)		0.39
Alpha	1.00	Stream Power (lb/ft s)	147.50	-17.00
11.00				
Frctn Loss (ft)	0.44	Cum Volume (acre-ft)		0.50
C & E Loss (ft)	0.02	Cum SA (acres)		0.18

Warning: The conveyance ratio (upstream conveyance divided by downstream conveyance) is less than 0.7 or greater than 1.4.

This may indicate the need for additional cross sections.

Note: Multiple critical depths were found at this location. The critical depth with the lowest, valid, energy was used.

CROSS SECTION OUTPUT Profile #PF 22

E.G. Elev (ft)	653.50	Element	Left OB	Channel
Right OB				
Vel Head (ft)	0.35	wt. n-val.		0.030
W.S. Elev (ft)	653.15	Reach Len. (ft)	134.00	150.00
128.00				
Crit W.S. (ft)	651.53	Flow Area (sq ft)		84.37
E.G. Slope (ft/ft)	0.002212	Area (sq ft)		84.37
Q Total (cfs)	400.00	Flow (cfs)		400.00
Top Width (ft)	26.41	Top Width (ft)		26.41
Vel Total (ft/s)	4.74	Avg. Vel. (ft/s)		4.74
Max Chl Dpth (ft)	5.05	Hydr. Depth (ft)		3.19
Conv. Total (cfs)	8505.4	Conv. (cfs)		8505.4
Length Wtd. (ft)	150.00	wetted Per. (ft)		29.06
Min Ch El (ft)	648.10	Shear (lb/sq ft)		0.40
Alpha	1.00	Stream Power (lb/ft s)	147.50	-17.00
11.00				

Frctn Loss (ft)	0.45	westTribClow.rep Cum Volume (acre-ft)	0.52
C & E Loss (ft)	0.02	Cum SA (acres)	0.18

Note: Multiple critical depths were found at this location. The critical depth with the lowest, valid, energy was used.

CROSS SECTION OUTPUT Profile #PF 23

E.G. Elev (ft)	653.65	Element	Left OB	Channel
Right OB Vel Head (ft)	0.36	wt. n-val.		0.030
W.S. Elev (ft)	653.28	Reach Len. (ft)	134.00	150.00
128.00 Crit w.s. (ft)	651.62	Flow Area (sq ft)		88.09
E.G. slope (ft/ft)	0.002255	Area (sq ft)		88.09
Q Total (cfs)	425.00	Flow (cfs)		425.00
Top width (ft)	27.28	Top width (ft)		27.28
vel Total (ft/s)	4.82	Avg. vel. (ft/s)		4.82
Max Chl Dpth (ft)	5.18	Hydr. Depth (ft)		3.23
Conv. Total (cfs)	8949.3	Conv. (cfs)		8949.3
Length wtd. (ft)	150.00	wetted Per. (ft)		29.99
Min Ch El (ft)	648.10	Shear (lb/sq ft)		0.41
Alpha	1.00	Stream Power (lb/ft s)	147.50	-17.00
11.00 Frctn Loss (ft)	0.45	Cum volume (acre-ft)		0.55
C & E Loss (ft)	0.02	Cum SA (acres)		0.19

Note: Multiple critical depths were found at this location. The critical depth with the lowest, valid, energy was used.

CROSS SECTION OUTPUT Profile #PF 24

E.G. Elev (ft)	653.79	Element	Left OB	Channel
Right OB Vel Head (ft)	0.37	wt. n-val.	0.080	0.030
W.S. Elev (ft)	653.42	Reach Len. (ft)	134.00	150.00
128.00 Crit w.s. (ft)	651.73	Flow Area (sq ft)	0.62	91.78
E.G. slope (ft/ft)	0.002282	Area (sq ft)	44.85	91.78
Q Total (cfs)	450.00	Flow (cfs)	0.12	449.88

westTribClow.rep

Top width (ft)	136.45	Top width (ft)	108.45	28.00
Vel Total (ft/s)	4.87	Avg. Vel. (ft/s)	0.20	4.90
Max Chl Dpth (ft)	5.32	Hydr. Depth (ft)	0.10	3.28
Conv. Total (cfs)	9421.0	Conv. (cfs)	2.6	9418.4
Length wtd. (ft)	150.00	wetted Per. (ft)	6.00	30.78
Min Ch El (ft)	648.10	Shear (lb/sq ft)	0.01	0.42
Alpha	1.01	Stream Power (lb/ft s)	147.50	-17.00
11.00		Cum volume (acre-ft)	0.07	0.57
Frctn Loss (ft)	0.45	Cum SA (acres)	0.17	0.19
C & E Loss (ft)	0.02			

Note: Multiple critical depths were found at this location. The critical depth with the lowest, valid, energy was used.

CROSS SECTION OUTPUT Profile #PF 25

E.G. Elev (ft)	653.88	Element	Left OB	Channel
Right OB				
Vel Head (ft)	0.40	wt. n-val.	0.080	0.030
W.S. Elev (ft)	653.48	Reach Len. (ft)	134.00	150.00
128.00				
Crit w.s. (ft)	651.84	Flow Area (sq ft)	0.97	93.39
E.G. slope (ft/ft)	0.002404	Area (sq ft)	51.20	93.39
Q Total (cfs)	475.00	Flow (cfs)	0.26	474.74
Top width (ft)	141.04	Top width (ft)	113.04	28.00
Vel Total (ft/s)	5.03	Avg. Vel. (ft/s)	0.27	5.08
Max Chl Dpth (ft)	5.38	Hydr. Depth (ft)	0.16	3.34
Conv. Total (cfs)	9688.1	Conv. (cfs)	5.3	9682.7
Length wtd. (ft)	149.66	wetted Per. (ft)	6.00	30.83
Min Ch El (ft)	648.10	Shear (lb/sq ft)	0.02	0.45
Alpha	1.02	Stream Power (lb/ft s)	147.50	-17.00
11.00		Cum volume (acre-ft)	0.18	0.60
Frctn Loss (ft)	0.43	Cum SA (acres)	0.39	0.19
0.02				
C & E Loss (ft)	0.01			
0.14				

Warning: Multiple water surfaces were found that could balance the energy equation. The program selected the water surface

whose main channel velocity head was the closest to the previously computed cross section.

Note: Multiple critical depths were found at this location. The critical depth with the lowest, valid, energy was used.

CROSS SECTION OUTPUT Profile #PF 26

E.G. Elev (ft)	653.95	Element	Left OB	Channel
Right OB				
Vel Head (ft)	0.36	wt. n-val.	0.080	0.030
0.080				
W.S. Elev (ft)	653.60	Reach Len. (ft)	134.00	150.00
128.00				
Crit w.s. (ft)	651.94	Flow Area (sq ft)	1.70	96.80
45.53				
E.G. slope (ft/ft)	0.002139	Area (sq ft)	65.59	96.80
45.53				
Q Total (cfs)	500.00	Flow (cfs)	0.63	475.25
24.13				
Top width (ft)	244.68	Top width (ft)	122.80	28.00
93.89				
Vel Total (ft/s)	3.47	Avg. vel. (ft/s)	0.37	4.91
0.53				
Max Chl Dpth (ft)	5.50	Hydr. Depth (ft)	0.28	3.46
0.48				
Conv. Total (cfs)	10810.0	Conv. (cfs)	13.6	10274.8
521.6				
Length wtd. (ft)	148.91	wetted Per. (ft)	6.00	30.86
94.01				
Min Ch El (ft)	648.10	Shear (lb/sq ft)	0.04	0.42
0.06				
Alpha	1.90	Stream Power (lb/ft s)	147.50	-17.00
11.00				
Frctn Loss (ft)	0.39	Cum Volume (acre-ft)	0.23	0.63
0.11				
C & E Loss (ft)	0.01	Cum SA (acres)	0.45	0.20
0.38				

Note: Multiple critical depths were found at this location. The critical depth with the lowest, valid, energy was used.

CROSS SECTION OUTPUT Profile #PF 27

E.G. Elev (ft)	654.04	Element	Left OB	Channel
Right OB				
Vel Head (ft)	0.37	wt. n-val.	0.080	0.030
0.080				
W.S. Elev (ft)	653.67	Reach Len. (ft)	134.00	150.00
128.00				
Crit w.s. (ft)	652.03	Flow Area (sq ft)	2.13	98.81
52.48				
E.G. slope (ft/ft)	0.002164	Area (sq ft)	74.59	98.81
52.48				
Q Total (cfs)	525.00	Flow (cfs)	0.92	494.59
29.49				
Top width (ft)	256.44	Top width (ft)	128.53	28.00
99.91				
Vel Total (ft/s)	3.42	Avg. vel. (ft/s)	0.43	5.01
0.56				

westTribClow.rep				
Max Chl Dpth (ft)	5.57	Hydr. Depth (ft)	0.35	3.53
0.53				
Conv. Total (cfs)	11286.0	Conv. (cfs)	19.8	10632.2
634.0				
Length wtd. (ft)	148.64	wetted Per. (ft)	6.00	30.86
100.03				
Min Ch El (ft)	648.10	Shear (lb/sq ft)	0.05	0.43
0.07				
Alpha	2.02	Stream Power (lb/ft s)	147.50	-17.00
11.00				
Frctn Loss (ft)	0.38	Cum Volume (acre-ft)	0.36	0.65
0.15				
C & E Loss (ft)	0.01	Cum SA (acres)	0.92	0.20
0.42				

Note: Multiple critical depths were found at this location. The critical depth with the lowest, valid, energy was used.

CROSS SECTION OUTPUT Profile #PF 28

E.G. Elev (ft)	654.11	Element	Left OB	Channel
Right OB				
Vel Head (ft)	0.38	wt. n-val.	0.080	0.030
0.080				
W.S. Elev (ft)	653.73	Reach Len. (ft)	134.00	150.00
128.00				
Crit w.s. (ft)	652.13	Flow Area (sq ft)	2.52	100.61
59.10				
E.G. slope (ft/ft)	0.002200	Area (sq ft)	83.04	100.61
59.10				
Q Total (cfs)	550.00	Flow (cfs)	1.23	513.98
34.79				
Top width (ft)	267.98	Top width (ft)	133.68	28.00
106.30				
Vel Total (ft/s)	3.39	Avg. Vel. (ft/s)	0.49	5.11
0.59				
Max Chl Dpth (ft)	5.63	Hydr. Depth (ft)	0.42	3.59
0.56				
Conv. Total (cfs)	11725.3	Conv. (cfs)	26.2	10957.5
741.6				
Length wtd. (ft)	148.34	wetted Per. (ft)	6.00	30.86
106.42				
Min Ch El (ft)	648.10	Shear (lb/sq ft)	0.06	0.45
0.08				
Alpha	2.12	Stream Power (lb/ft s)	147.50	-17.00
11.00				
Frctn Loss (ft)	0.37	Cum Volume (acre-ft)	0.47	0.67
0.19				
C & E Loss (ft)	0.01	Cum SA (acres)	1.08	0.20
0.45				

Note: Multiple critical depths were found at this location. The critical depth with the lowest, valid, energy was used.

CROSS SECTION OUTPUT Profile #PF 29

E.G. Elev (ft)	654.18	Element	Left OB	Channel
----------------	--------	---------	---------	---------

westTribClow.rep

Right OB				
Vel Head (ft)	0.40	wt. n-val.	0.080	0.030
0.080				
W.S. Elev (ft)	653.78	Reach Len. (ft)	134.00	150.00
128.00				
Crit w.s. (ft)	652.22	Flow Area (sq ft)	2.81	101.97
64.38				
E.G. slope (ft/ft)	0.002272	Area (sq ft)	89.60	101.97
64.38				
Q Total (cfs)	575.00	Flow (cfs)	1.50	534.08
39.42				
Top width (ft)	277.34	Top width (ft)	137.55	28.00
111.78				
Vel Total (ft/s)	3.40	Avg. vel. (ft/s)	0.53	5.24
0.61				
Max Chl Dpth (ft)	5.68	Hydr. Depth (ft)	0.47	3.64
0.58				
Conv. Total (cfs)	12063.1	Conv. (cfs)	31.4	11204.6
827.1				
Length wtd. (ft)	148.46	wetted Per. (ft)	6.00	30.86
111.90				
Min Ch El (ft)	648.10	Shear (lb/sq ft)	0.07	0.47
0.08				
Alpha	2.21	Stream Power (lb/ft s)	147.50	-17.00
11.00				
Frctn Loss (ft)	0.42	Cum Volume (acre-ft)	0.57	0.68
0.29				
C & E Loss (ft)	0.01	Cum SA (acres)	1.15	0.20
0.70				

Note: Multiple critical depths were found at this location. The critical depth with the lowest, valid, energy was used.

CROSS SECTION OUTPUT Profile #PF 30

E.G. Elev (ft)	654.24	Element	Left OB	Channel
Right OB				
Vel Head (ft)	0.41	wt. n-val.	0.080	0.030
0.080				
W.S. Elev (ft)	653.84	Reach Len. (ft)	134.00	150.00
128.00				
Crit w.s. (ft)	652.31	Flow Area (sq ft)	3.13	103.49
70.55				
E.G. slope (ft/ft)	0.002314	Area (sq ft)	97.19	103.49
70.62				
Q Total (cfs)	600.00	Flow (cfs)	1.81	552.44
45.74				
Top width (ft)	287.93	Top width (ft)	141.99	28.00
117.94				
Vel Total (ft/s)	3.39	Avg. vel. (ft/s)	0.58	5.34
0.65				
Max Chl Dpth (ft)	5.74	Hydr. Depth (ft)	0.52	3.70
0.62				
Conv. Total (cfs)	12473.1	Conv. (cfs)	37.7	11484.5
950.9				
Length wtd. (ft)	148.19	wetted Per. (ft)	6.00	30.86
114.12				
Min Ch El (ft)	648.10	Shear (lb/sq ft)	0.08	0.48
0.09				
Alpha	2.29	Stream Power (lb/ft s)	147.50	-17.00

WestTribClow.rep

11.00					
Frctn Loss (ft)	0.41	Cum volume (acre-ft)	0.70	0.70	
0.36					
C & E Loss (ft)	0.01	Cum SA (acres)	1.20	0.21	
0.76					

Note: Multiple critical depths were found at this location. The critical depth with the lowest, valid, energy was used.

CROSS SECTION

RIVER: WestTribClow
 REACH: WestTribClow RS: 1200

INPUT

Description: Sta 12+00

Station Elevation Data	num=	25							
Sta Elev Sta Elev Sta Elev Sta Elev Sta Elev									
-211 654 -158.5 653.5 -97 653 -52 652.1 -18.5 652.7									
-16.5 653 -13.5 653.7 -9.5 653 -8.5 652 -7.5 651									
-5 650 -3 649 0 648 2 648 5 649									
11 650 12 651 14 652 16 653 21 653.1									
25.5 653 56 652.7 100 653 125.5 653.2 154.5 654									

Manning's n Values	num=	3
Sta n Val Sta n Val Sta n Val		
-211 .08 -9.5 .03 16 .08		

Bank Sta: Left Right	Lengths: Left Channel Right	Coeff Contr.	Expan.
-9.5 16	112 100 97	.1	.3
Ineffective Flow	num=	1	
Sta L Sta R Elev Permanent			
-211 -61 658.1 F			
Left Levee Station=	-13.5 Elevation=	652.8	
Right Levee Station=	21 Elevation=	652.8	

CROSS SECTION OUTPUT Profile #PF 1

E.G. Elev (ft)	648.96	Element	Left OB	Channel
Right OB				
Vel Head (ft)	0.10	wt. n-val.		0.030
W.S. Elev (ft)	648.86	Reach Len. (ft)	112.00	100.00
97.00				
Crit W.S. (ft)	648.66	Flow Area (sq ft)		3.92
E.G. Slope (ft/ft)	0.006235	Area (sq ft)		3.92
Q Total (cfs)	10.00	Flow (cfs)		10.00
Top Width (ft)	7.14	Top Width (ft)		7.14
Vel Total (ft/s)	2.55	Avg. Vel. (ft/s)		2.55
Max Chl Dpth (ft)	0.86	Hydr. Depth (ft)		0.55
Conv. Total (cfs)	126.6	Conv. (cfs)		126.6
Length wtd. (ft)	100.00	wetted Per. (ft)		7.42

westTribClow.rep

Min Ch El (ft)	648.00	Shear (lb/sq ft)		0.21
Alpha 21.00	1.00	Stream Power (lb/ft s)	154.50	-13.50
Frctn Loss (ft)	0.58	Cum Volume (acre-ft)		0.02
C & E Loss (ft)	0.01	Cum SA (acres)		0.03

Note: Multiple critical depths were found at this location. The critical depth with the lowest, valid, energy was used.

CROSS SECTION OUTPUT Profile #PF 2

E.G. Elev (ft)	649.32	Element	Left OB	Channel
Right OB Vel Head (ft)	0.15	wt. n-Val.		0.030
W.S. Elev (ft)	649.17	Reach Len. (ft)	112.00	100.00
97.00 Crit w.s. (ft)	648.94	Flow Area (sq ft)		6.48
E.G. Slope (ft/ft)	0.006681	Area (sq ft)		6.48
Q Total (cfs)	20.00	Flow (cfs)		20.00
Top width (ft)	9.37	Top width (ft)		9.37
Vel Total (ft/s)	3.09	Avg. vel. (ft/s)		3.09
Max Chl Dpth (ft)	1.17	Hydr. Depth (ft)		0.69
Conv. Total (cfs)	244.7	Conv. (cfs)		244.7
Length wtd. (ft)	100.00	wetted Per. (ft)		9.75
Min Ch El (ft)	648.00	Shear (lb/sq ft)		0.28
Alpha 21.00	1.00	Stream Power (lb/ft s)	154.50	-13.50
Frctn Loss (ft)	0.61	Cum Volume (acre-ft)		0.03
C & E Loss (ft)	0.01	Cum SA (acres)		0.04

Note: Multiple critical depths were found at this location. The critical depth with the lowest, valid, energy was used.

CROSS SECTION OUTPUT Profile #PF 3

E.G. Elev (ft)	649.58	Element	Left OB	Channel
Right OB Vel Head (ft)	0.18	wt. n-Val.		0.030
W.S. Elev (ft)	649.41	Reach Len. (ft)	112.00	100.00
97.00				

westTribClow.rep				
Crit w.s. (ft)	649.16	Flow Area (sq ft)		8.90
E.G. Slope (ft/ft)	0.006669	Area (sq ft)		8.90
Q Total (cfs)	30.00	Flow (cfs)		30.00
Top width (ft)	11.24	Top width (ft)		11.24
Vel Total (ft/s)	3.37	Avg. Vel. (ft/s)		3.37
Max Chl Dpth (ft)	1.41	Hydr. Depth (ft)		0.79
Conv. Total (cfs)	367.4	Conv. (cfs)		367.4
Length wtd. (ft)	100.00	wetted Per. (ft)		11.70
Min Ch El (ft)	648.00	Shear (lb/sq ft)		0.32
Alpha	1.00	Stream Power (lb/ft s)	154.50	-13.50
Frctn Loss (ft)	0.61	Cum Volume (acre-ft)		0.04
C & E Loss (ft)	0.00	Cum SA (acres)		0.05

Note: Multiple critical depths were found at this location. The critical depth with the lowest, valid, energy was used.

CROSS SECTION OUTPUT Profile #PF 4

E.G. Elev (ft)	649.79	Element	Left OB	Channel
Right OB Vel Head (ft)	0.20	wt. n-val.		0.030
w.s. Elev (ft)	649.59	Reach Len. (ft)	112.00	100.00
97.00 Crit w.s. (ft)	649.34	Flow Area (sq ft)		11.13
E.G. Slope (ft/ft)	0.006639	Area (sq ft)		11.13
Q Total (cfs)	40.00	Flow (cfs)		40.00
Top width (ft)	12.73	Top width (ft)		12.73
Vel Total (ft/s)	3.59	Avg. Vel. (ft/s)		3.59
Max Chl Dpth (ft)	1.59	Hydr. Depth (ft)		0.87
Conv. Total (cfs)	490.9	Conv. (cfs)		490.9
Length wtd. (ft)	100.00	wetted Per. (ft)		13.24
Min Ch El (ft)	648.00	Shear (lb/sq ft)		0.35
Alpha	1.00	Stream Power (lb/ft s)	154.50	-13.50
21.00 Frctn Loss (ft)	0.62	Cum Volume (acre-ft)		0.05
C & E Loss (ft)	0.00	Cum SA (acres)		0.05

WestTribClow.rep

Note: Multiple critical depths were found at this location. The critical depth with the lowest, valid, energy was used.

CROSS SECTION OUTPUT Profile #PF 5

E.G. Elev (ft)	649.97	Element	Left OB	Channel
Right OB Vel Head (ft)	0.22	wt. n-Val.		0.030
W.S. Elev (ft)	649.75	Reach Len. (ft)	112.00	100.00
97.00 Crit w.s. (ft)	649.48	Flow Area (sq ft)		13.27
E.G. Slope (ft/ft)	0.006559	Area (sq ft)		13.27
Q Total (cfs)	50.00	Flow (cfs)		50.00
Top width (ft)	14.01	Top width (ft)		14.01
Vel Total (ft/s)	3.77	Avg. Vel. (ft/s)		3.77
Max Chl Dpth (ft)	1.75	Hydr. Depth (ft)		0.95
Conv. Total (cfs)	617.4	Conv. (cfs)		617.4
Length wtd. (ft)	100.00	wetted Per. (ft)		14.58
Min Ch El (ft)	648.00	Shear (lb/sq ft)		0.37
Alpha	1.00	Stream Power (lb/ft s)	154.50	-13.50
21.00 Frctn Loss (ft)	0.62	Cum Volume (acre-ft)		0.06
C & E Loss (ft)	0.00	Cum SA (acres)		0.06

Note: Multiple critical depths were found at this location. The critical depth with the lowest, valid, energy was used.

CROSS SECTION OUTPUT Profile #PF 6

E.G. Elev (ft)	650.13	Element	Left OB	Channel
Right OB Vel Head (ft)	0.24	wt. n-Val.		0.030
W.S. Elev (ft)	649.90	Reach Len. (ft)	112.00	100.00
97.00 Crit w.s. (ft)	649.60	Flow Area (sq ft)		15.38
E.G. Slope (ft/ft)	0.006414	Area (sq ft)		15.38
Q Total (cfs)	60.00	Flow (cfs)		60.00
Top width (ft)	15.17	Top width (ft)		15.17
Vel Total (ft/s)	3.90	Avg. Vel. (ft/s)		3.90

westTribClow.rep

Max Chl Dpth (ft)	1.90	Hydr. Depth (ft)		1.01
Conv. Total (cfs)	749.2	Conv. (cfs)		749.2
Length wtd. (ft)	100.00	wetted Per. (ft)		15.78
Min Ch El (ft)	648.00	Shear (lb/sq ft)		0.39
Alpha 21.00	1.00	Stream Power (lb/ft s)	154.50	-13.50
Frctn Loss (ft)	0.62	Cum Volume (acre-ft)		0.06
C & E Loss (ft)	0.00	Cum SA (acres)		0.06

Note: Multiple critical depths were found at this location. The critical depth with the lowest, valid, energy was used.

CROSS SECTION OUTPUT Profile #PF 7

E.G. Elev (ft)	650.28	Element	Left OB	Channel
Right OB Vel Head (ft)	0.25	wt. n-Val.		0.030
W.S. Elev (ft)	650.03	Reach Len. (ft)	112.00	100.00
97.00 Crit w.s. (ft)	649.71	Flow Area (sq ft)		17.46
E.G. Slope (ft/ft)	0.006206	Area (sq ft)		17.46
Q Total (cfs)	70.00	Flow (cfs)		70.00
Top width (ft)	16.10	Top width (ft)		16.10
Vel Total (ft/s)	4.01	Avg. vel. (ft/s)		4.01
Max Chl Dpth (ft)	2.03	Hydr. Depth (ft)		1.08
Conv. Total (cfs)	888.6	Conv. (cfs)		888.6
Length wtd. (ft)	100.00	wetted Per. (ft)		16.76
Min Ch El (ft)	648.00	Shear (lb/sq ft)		0.40
Alpha 21.00	1.00	Stream Power (lb/ft s)	154.50	-13.50
Frctn Loss (ft)	0.61	Cum Volume (acre-ft)		0.07
C & E Loss (ft)	0.00	Cum SA (acres)		0.06

Note: Multiple critical depths were found at this location. The critical depth with the lowest, valid, energy was used.

CROSS SECTION OUTPUT Profile #PF 8

westTribClow.rep				
		Element	Left OB	Channel
E.G. Elev (ft)	650.41			
Right OB				
Vel Head (ft)	0.27	wt. n-Val.		0.030
W.S. Elev (ft)	650.14	Reach Len. (ft)	112.00	100.00
97.00				
Crit w.s. (ft)	649.81	Flow Area (sq ft)		19.35
E.G. Slope (ft/ft)	0.005971	Area (sq ft)		19.35
Q Total (cfs)	80.00	Flow (cfs)		80.00
Top width (ft)	16.51	Top width (ft)		16.51
Vel Total (ft/s)	4.13	Avg. Vel. (ft/s)		4.13
Max Chl Dpth (ft)	2.14	Hydr. Depth (ft)		1.17
Conv. Total (cfs)	1035.3	Conv. (cfs)		1035.3
Length wtd. (ft)	100.00	wetted Per. (ft)		17.24
Min Ch El (ft)	648.00	Shear (lb/sq ft)		0.42
Alpha	1.00	Stream Power (lb/ft s)	154.50	-13.50
21.00				
Frctn Loss (ft)	0.60	Cum Volume (acre-ft)		0.08
C & E Loss (ft)	0.00	Cum SA (acres)		0.06

Note: Multiple critical depths were found at this location. The critical depth with the lowest, valid, energy was used.

CROSS SECTION OUTPUT Profile #PF 9

		Element	Left OB	Channel
E.G. Elev (ft)	650.54			
Right OB				
Vel Head (ft)	0.28	wt. n-Val.		0.030
W.S. Elev (ft)	650.26	Reach Len. (ft)	112.00	100.00
97.00				
Crit w.s. (ft)	649.92	Flow Area (sq ft)		21.20
E.G. Slope (ft/ft)	0.005775	Area (sq ft)		21.20
Q Total (cfs)	90.00	Flow (cfs)		90.00
Top width (ft)	16.89	Top width (ft)		16.89
Vel Total (ft/s)	4.25	Avg. Vel. (ft/s)		4.25
Max Chl Dpth (ft)	2.26	Hydr. Depth (ft)		1.25
Conv. Total (cfs)	1184.3	Conv. (cfs)		1184.3
Length wtd. (ft)	100.00	wetted Per. (ft)		17.69
Min Ch El (ft)	648.00	Shear (lb/sq ft)		0.43

	Alpha	Frctn Loss (ft)	C & E Loss (ft)	westTribClow.rep Stream Power (lb/ft s)	154.50	-13.50
	21.00	0.59	0.01	Cum Volume (acre-ft)		0.09
				Cum SA (acres)		0.07

Note: Multiple critical depths were found at this location. The critical depth with the lowest, valid, energy was used.

CROSS SECTION OUTPUT Profile #PF 10

	E.G. Elev (ft)	Element	Left OB	Channel
Right OB	650.65			
Vel Head (ft)	0.29	wt. n-Val.		0.030
W.S. Elev (ft)	650.36	Reach Len. (ft)	112.00	100.00
97.00				
Crit w.s. (ft)	650.01	Flow Area (sq ft)		22.99
E.G. Slope (ft/ft)	0.005619	Area (sq ft)		22.99
Q Total (cfs)	100.00	Flow (cfs)		100.00
Top width (ft)	17.26	Top width (ft)		17.26
Vel Total (ft/s)	4.35	Avg. Vel. (ft/s)		4.35
Max Chl Dpth (ft)	2.36	Hydr. Depth (ft)		1.33
Conv. Total (cfs)	1334.0	Conv. (cfs)		1334.0
Length wtd. (ft)	100.00	wetted Per. (ft)		18.12
Min Ch El (ft)	648.00	Shear (lb/sq ft)		0.44
Alpha	1.00	Stream Power (lb/ft s)	154.50	-13.50
21.00				
Frctn Loss (ft)	0.58	Cum Volume (acre-ft)		0.09
C & E Loss (ft)	0.01	Cum SA (acres)		0.07

Note: Multiple critical depths were found at this location. The critical depth with the lowest, valid, energy was used.

CROSS SECTION OUTPUT Profile #PF 11

	E.G. Elev (ft)	Element	Left OB	Channel
Right OB	650.93			
Vel Head (ft)	0.33	wt. n-Val.		0.030
W.S. Elev (ft)	650.60	Reach Len. (ft)	112.00	100.00
97.00				
Crit w.s. (ft)	650.19	Flow Area (sq ft)		27.31
E.G. slope (ft/ft)	0.005312	Area (sq ft)		27.31

westTribClow.rep

Q Total (cfs)	125.00	Flow (cfs)		125.00
Top width (ft)	18.12	Top width (ft)		18.12
Vel Total (ft/s)	4.58	Avg. Vel. (ft/s)		4.58
Max Chl Dpth (ft)	2.60	Hydr. Depth (ft)		1.51
Conv. Total (cfs)	1715.1	Conv. (cfs)		1715.1
Length wtd. (ft)	100.00	wetted Per. (ft)		19.13
Min Ch El (ft)	648.00	Shear (lb/sq ft)		0.47
Alpha 21.00	1.00	Stream Power (lb/ft s)	154.50	-13.50
Frctn Loss (ft)	0.57	Cum Volume (acre-ft)		0.11
C & E Loss (ft)	0.01	Cum SA (acres)		0.07

Note: Multiple critical depths were found at this location. The critical depth with the lowest, valid, energy was used.

CROSS SECTION OUTPUT Profile #PF 12

E.G. Elev (ft)	651.18	Element	Left OB	Channel
Right OB Vel Head (ft)	0.35	wt. n-val.		0.030
W.S. Elev (ft)	650.83	Reach Len. (ft)	112.00	100.00
97.00 Crit W.S. (ft)	650.36	Flow Area (sq ft)		31.43
E.G. Slope (ft/ft)	0.005093	Area (sq ft)		31.43
Q Total (cfs)	150.00	Flow (cfs)		150.00
Top width (ft)	18.90	Top width (ft)		18.90
Vel Total (ft/s)	4.77	Avg. Vel. (ft/s)		4.77
Max Chl Dpth (ft)	2.83	Hydr. Depth (ft)		1.66
Conv. Total (cfs)	2101.8	Conv. (cfs)		2101.8
Length wtd. (ft)	100.00	wetted Per. (ft)		20.04
Min Ch El (ft)	648.00	Shear (lb/sq ft)		0.50
Alpha 21.00	1.00	Stream Power (lb/ft s)	154.50	-13.50
Frctn Loss (ft)	0.55	Cum Volume (acre-ft)		0.12
C & E Loss (ft)	0.01	Cum SA (acres)		0.07

Note: Multiple critical depths were found at this location. The critical depth with the lowest, valid, energy was used.

CROSS SECTION OUTPUT Profile #PF 13

E.G. Elev (ft)	651.41	Element	Left OB	Channel
Right OB Vel Head (ft)	0.38	wt. n-Val.		0.030
W.S. Elev (ft)	651.03	Reach Len. (ft)	112.00	100.00
97.00 Crit w.s. (ft)	650.51	Flow Area (sq ft)		35.40
E.G. Slope (ft/ft)	0.004926	Area (sq ft)		35.40
Q Total (cfs)	175.00	Flow (cfs)		175.00
Top width (ft)	19.60	Top width (ft)		19.60
Vel Total (ft/s)	4.94	Avg. Vel. (ft/s)		4.94
Max Chl Dpth (ft)	3.03	Hydr. Depth (ft)		1.81
Conv. Total (cfs)	2493.4	Conv. (cfs)		2493.4
Length wtd. (ft)	100.00	wetted Per. (ft)		20.87
Min Ch El (ft)	648.00	Shear (lb/sq ft)		0.52
Alpha	1.00	Stream Power (lb/ft s)	154.50	-13.50
21.00 Frctn Loss (ft)	0.55	Cum Volume (acre-ft)		0.14
C & E Loss (ft)	0.01	Cum SA (acres)		0.08

Note: Multiple critical depths were found at this location. The critical depth with the lowest, valid, energy was used.

CROSS SECTION OUTPUT Profile #PF 14

E.G. Elev (ft)	651.63	Element	Left OB	Channel
Right OB Vel Head (ft)	0.40	wt. n-Val.		0.030
W.S. Elev (ft)	651.22	Reach Len. (ft)	112.00	100.00
97.00 Crit w.s. (ft)	650.64	Flow Area (sq ft)		39.20
E.G. Slope (ft/ft)	0.004783	Area (sq ft)		39.20
Q Total (cfs)	200.00	Flow (cfs)		200.00
Top width (ft)	20.17	Top width (ft)		20.17
Vel Total (ft/s)	5.10	Avg. Vel. (ft/s)		5.10
Max Chl Dpth (ft)	3.22	Hydr. Depth (ft)		1.94

	westTribCflow.rep		
Conv. Total (cfs)	2891.7	Conv. (cfs)	2891.7
Length wtd. (ft)	100.00	wetted Per. (ft)	21.57
Min Ch El (ft)	648.00	Shear (lb/sq ft)	0.54
Alpha	1.00	Stream Power (lb/ft s)	154.50
Frctn Loss (ft)	0.53	Cum Volume (acre-ft)	0.15
C & E Loss (ft)	0.01	Cum SA (acres)	0.08

Note: Multiple critical depths were found at this location. The critical depth with the lowest, valid, energy was used.

CROSS SECTION OUTPUT Profile #PF 15

E.G. Elev (ft)	651.83	Element	Left OB	Channel
Right OB Vel Head (ft)	0.43	wt. n-val.		0.030
w.s. Elev (ft)	651.40	Reach Len. (ft)	112.00	100.00
97.00 Crit w.s. (ft)	650.79	Flow Area (sq ft)		42.89
E.G. Slope (ft/ft)	0.004670	Area (sq ft)		42.89
Q Total (cfs)	225.00	Flow (cfs)		225.00
Top width (ft)	20.71	Top width (ft)		20.71
Vel Total (ft/s)	5.25	Avg. Vel. (ft/s)		5.25
Max Chl Dpth (ft)	3.40	Hydr. Depth (ft)		2.07
Conv. Total (cfs)	3292.3	Conv. (cfs)		3292.3
Length wtd. (ft)	100.00	wetted Per. (ft)		22.23
Min Ch El (ft)	648.00	Shear (lb/sq ft)		0.56
Alpha	1.00	Stream Power (lb/ft s)	154.50	-13.50
21.00 Frctn Loss (ft)	0.53	Cum Volume (acre-ft)		0.17
C & E Loss (ft)	0.01	Cum SA (acres)		0.08

Note: Multiple critical depths were found at this location. The critical depth with the lowest, valid, energy was used.

CROSS SECTION OUTPUT Profile #PF 16

E.G. Elev (ft)	652.03	Element	Left OB	Channel
Right OB Vel Head (ft)	0.45	wt. n-val.		0.030

WestTribClow.rep

W.S. Elev (ft)	651.58	Reach Len. (ft)	112.00	100.00
97.00				
Crit w.s. (ft)	650.93	Flow Area (sq ft)		46.48
E.G. Slope (ft/ft)	0.004577	Area (sq ft)		46.48
Q Total (cfs)	250.00	Flow (cfs)		250.00
Top width (ft)	21.23	Top width (ft)		21.23
Vel Total (ft/s)	5.38	Avg. Vel. (ft/s)		5.38
Max Chl Dpth (ft)	3.58	Hydr. Depth (ft)		2.19
Conv. Total (cfs)	3695.4	Conv. (cfs)		3695.4
Length wtd. (ft)	100.00	wetted Per. (ft)		22.85
Min Ch El (ft)	648.00	Shear (lb/sq ft)		0.58
Alpha	1.00	Stream Power (lb/ft s)	154.50	-13.50
21.00				
Frctn Loss (ft)	0.52	Cum Volume (acre-ft)		0.18
C & E Loss (ft)	0.01	Cum SA (acres)		0.08

Note: Multiple critical depths were found at this location. The critical depth with the lowest, valid, energy was used.

CROSS SECTION OUTPUT Profile #PF 17

E.G. Elev (ft)	652.21	Element	Left OB	Channel
Right OB				
Vel Head (ft)	0.47	wt. n-val.		0.030
W.S. Elev (ft)	651.74	Reach Len. (ft)	112.00	100.00
97.00				
Crit w.s. (ft)	651.06	Flow Area (sq ft)		49.99
E.G. Slope (ft/ft)	0.004496	Area (sq ft)		49.99
Q Total (cfs)	275.00	Flow (cfs)		275.00
Top width (ft)	21.72	Top width (ft)		21.72
Vel Total (ft/s)	5.50	Avg. Vel. (ft/s)		5.50
Max Chl Dpth (ft)	3.74	Hydr. Depth (ft)		2.30
Conv. Total (cfs)	4101.2	Conv. (cfs)		4101.2
Length wtd. (ft)	100.00	wetted Per. (ft)		23.45
Min Ch El (ft)	648.00	Shear (lb/sq ft)		0.60
Alpha	1.00	Stream Power (lb/ft s)	154.50	-13.50
21.00				
Frctn Loss (ft)	0.51	Cum Volume (acre-ft)		0.20

WestTribClow.rep

C & E Loss (ft) 0.01 Cum SA (acres) 0.09

Note: Multiple critical depths were found at this location. The critical depth with the lowest, valid, energy was used.

CROSS SECTION OUTPUT Profile #PF 18

E.G. Elev (ft)	652.39	Element	Left OB	Channel
Right OB Vel Head (ft)	0.49	wt. n-Val.		0.030
W.S. Elev (ft)	651.90	Reach Len. (ft)	112.00	100.00
97.00 Crit w.s. (ft)	651.18	Flow Area (sq ft)		53.41
E.G. Slope (ft/ft)	0.004430	Area (sq ft)		53.41
Q Total (cfs)	300.00	Flow (cfs)		300.00
Top width (ft)	22.19	Top width (ft)		22.19
Vel Total (ft/s)	5.62	Avg. Vel. (ft/s)		5.62
Max Chl Dpth (ft)	3.90	Hydr. Depth (ft)		2.41
Conv. Total (cfs)	4507.1	Conv. (cfs)		4507.1
Length wtd. (ft)	100.00	wetted Per. (ft)		24.02
Min Ch El (ft)	648.00	Shear (lb/sq ft)		0.62
Alpha	1.00	Stream Power (lb/ft s)	154.50	-13.50
21.00 Frctn Loss (ft)	0.50	Cum Volume (acre-ft)		0.21
C & E Loss (ft)	0.01	Cum SA (acres)		0.09

Note: Multiple critical depths were found at this location. The critical depth with the lowest, valid, energy was used.

CROSS SECTION OUTPUT Profile #PF 19

E.G. Elev (ft)	652.55	Element	Left OB	Channel
Right OB Vel Head (ft)	0.51	wt. n-Val.		0.030
W.S. Elev (ft)	652.05	Reach Len. (ft)	112.00	100.00
97.00 Crit w.s. (ft)	651.29	Flow Area (sq ft)		56.77
E.G. Slope (ft/ft)	0.004373	Area (sq ft)		56.77
Q Total (cfs)	325.00	Flow (cfs)		325.00

westTribClow.rep				
Top width (ft)	22.64	Top width (ft)		22.64
Vel Total (ft/s)	5.72	Avg. Vel. (ft/s)		5.72
Max Chl Dpth (ft)	4.05	Hydr. Depth (ft)		2.51
Conv. Total (cfs)	4914.9	Conv. (cfs)		4914.9
Length wtd. (ft)	100.00	wetted Per. (ft)		24.57
Min Ch El (ft)	648.00	Shear (lb/sq ft)		0.63
Alpha	1.00	Stream Power (lb/ft s)	154.50	-13.50
Frctn Loss (ft)	0.49	Cum Volume (acre-ft)		0.22
C & E Loss (ft)	0.01	Cum SA (acres)		0.09

Note: Multiple critical depths were found at this location. The critical depth with the lowest, valid, energy was used.

CROSS SECTION OUTPUT Profile #PF 20

E.G. Elev (ft)	652.72	Element	Left OB	Channel
Right OB				
Vel Head (ft)	0.53	wt. n-Val.		0.030
W.S. Elev (ft)	652.19	Reach Len. (ft)	112.00	100.00
97.00				
Crit w.s. (ft)	651.41	Flow Area (sq ft)		60.07
E.G. Slope (ft/ft)	0.004320	Area (sq ft)		60.07
Q Total (cfs)	350.00	Flow (cfs)		350.00
Top width (ft)	23.07	Top width (ft)		23.07
Vel Total (ft/s)	5.83	Avg. Vel. (ft/s)		5.83
Max Chl Dpth (ft)	4.19	Hydr. Depth (ft)		2.60
Conv. Total (cfs)	5324.9	Conv. (cfs)		5324.9
Length wtd. (ft)	100.00	wetted Per. (ft)		25.09
Min Ch El (ft)	648.00	Shear (lb/sq ft)		0.65
Alpha	1.00	Stream Power (lb/ft s)	154.50	-13.50
21.00				
Frctn Loss (ft)	0.49	Cum Volume (acre-ft)		0.24
C & E Loss (ft)	0.01	Cum SA (acres)		0.09

Note: Multiple critical depths were found at this location. The critical depth with the lowest, valid, energy was used.

CROSS SECTION OUTPUT Profile #PF 21

E.G. Elev (ft)	652.87	Element	Left OB	Channel
Right OB Vel Head (ft)	0.54	wt. n-val.		0.030
W.S. Elev (ft)	652.33	Reach Len. (ft)	112.00	100.00
97.00 Crit W.S. (ft)	651.52	Flow Area (sq ft)		63.34
E.G. Slope (ft/ft)	0.004271	Area (sq ft)		63.34
Q Total (cfs)	375.00	Flow (cfs)		375.00
Top width (ft)	23.49	Top width (ft)		23.49
Vel Total (ft/s)	5.92	Avg. Vel. (ft/s)		5.92
Max Chl Dpth (ft)	4.33	Hydr. Depth (ft)		2.70
Conv. Total (cfs)	5737.8	Conv. (cfs)		5737.8
Length wtd. (ft)	100.00	wetted Per. (ft)		25.60
Min Ch El (ft)	648.00	Shear (lb/sq ft)		0.66
Alpha	1.00	Stream Power (lb/ft s)	154.50	-13.50
21.00 Frctn Loss (ft)	0.48	Cum Volume (acre-ft)		0.25
C & E Loss (ft)	0.01	Cum SA (acres)		0.10

Note: Multiple critical depths were found at this location. The critical depth with the lowest, valid, energy was used.

CROSS SECTION OUTPUT Profile #PF 22

E.G. Elev (ft)	653.03	Element	Left OB	Channel
Right OB Vel Head (ft)	0.56	wt. n-val.		0.030
W.S. Elev (ft)	652.47	Reach Len. (ft)	112.00	100.00
97.00 Crit W.S. (ft)	651.62	Flow Area (sq ft)		66.57
E.G. Slope (ft/ft)	0.004224	Area (sq ft)		66.57
Q Total (cfs)	400.00	Flow (cfs)		400.00
Top width (ft)	23.90	Top width (ft)		23.90
Vel Total (ft/s)	6.01	Avg. Vel. (ft/s)		6.01
Max Chl Dpth (ft)	4.47	Hydr. Depth (ft)		2.79
Conv. Total (cfs)	6154.9	Conv. (cfs)		6154.9
Length wtd. (ft)	100.00	wetted Per. (ft)		26.10

westTribClow.rep

Min Ch El (ft)	648.00	Shear (lb/sq ft)		0.67
Alpha 21.00	1.00	Stream Power (lb/ft s)	154.50	-13.50
Frctn Loss (ft)	0.47	Cum Volume (acre-ft)		0.26
C & E Loss (ft)	0.01	Cum SA (acres)		0.10

Note: Multiple critical depths were found at this location. The critical depth with the lowest, valid, energy was used.

CROSS SECTION OUTPUT Profile #PF 23

E.G. Elev (ft)	653.17	Element	Left OB	Channel
Right OB Vel Head (ft)	0.58	wt. n-Val.		0.030
W.S. Elev (ft)	652.60	Reach Len. (ft)	112.00	100.00
97.00 Crit w.s. (ft)	651.72	Flow Area (sq ft)		69.73
E.G. Slope (ft/ft)	0.004186	Area (sq ft)		69.73
Q Total (cfs)	425.00	Flow (cfs)		425.00
Top width (ft)	24.29	Top width (ft)		24.29
Vel Total (ft/s)	6.10	Avg. vel. (ft/s)		6.10
Max Chl Dpth (ft)	4.60	Hydr. Depth (ft)		2.87
Conv. Total (cfs)	6568.9	Conv. (cfs)		6568.9
Length wtd. (ft)	100.00	wetted Per. (ft)		26.58
Min Ch El (ft)	648.00	Shear (lb/sq ft)		0.69
Alpha 21.00	1.00	Stream Power (lb/ft s)	154.50	-13.50
Frctn Loss (ft)	0.47	Cum Volume (acre-ft)		0.28
C & E Loss (ft)	0.01	Cum SA (acres)		0.10

Note: Multiple critical depths were found at this location. The critical depth with the lowest, valid, energy was used.

CROSS SECTION OUTPUT Profile #PF 24

E.G. Elev (ft)	653.32	Element	Left OB	Channel
Right OB Vel Head (ft)	0.59	wt. n-Val.		0.030
W.S. Elev (ft)	652.73	Reach Len. (ft)	112.00	100.00
97.00				

westTribClow.rep				
Crit w.s. (ft)	651.81	Flow Area (sq ft)		72.87
E.G. Slope (ft/ft)	0.004147	Area (sq ft)		72.87
Q Total (cfs)	450.00	Flow (cfs)		450.00
Top width (ft)	24.68	Top width (ft)		24.68
Vel Total (ft/s)	6.18	Avg. Vel. (ft/s)		6.18
Max Chl Dpth (ft)	4.73	Hydr. Depth (ft)		2.95
Conv. Total (cfs)	6987.9	Conv. (cfs)		6987.9
Length wtd. (ft)	100.00	wetted Per. (ft)		27.05
Min Ch El (ft)	648.00	Shear (lb/sq ft)		0.70
Alpha	1.00	Stream Power (lb/ft s)	154.50	-13.50
Frctn Loss (ft)	0.46	Cum Volume (acre-ft)		0.29
C & E Loss (ft)	0.01	Cum SA (acres)		0.10

Note: Multiple critical depths were found at this location. The critical depth with the lowest, valid, energy was used.

CROSS SECTION OUTPUT Profile #PF 25

		Element	Left OB	Channel
E.G. Elev (ft)	653.43			
Right OB				
Vel Head (ft)	0.51	wt. n-val.	0.080	0.030
0.080				
w.s. Elev (ft)	652.92	Reach Len. (ft)	112.00	100.00
97.00				
Crit w.s. (ft)	651.92	Flow Area (sq ft)	24.25	77.78
6.14				
E.G. Slope (ft/ft)	0.003539	Area (sq ft)	34.57	77.78
6.14				
Q Total (cfs)	475.00	Flow (cfs)	18.02	455.42
1.57				
Top width (ft)	156.57	Top width (ft)	76.10	25.27
55.20				
Vel Total (ft/s)	4.39	Avg. Vel. (ft/s)	0.74	5.86
0.26				
Max Chl Dpth (ft)	4.92	Hydr. Depth (ft)	0.55	3.08
0.11				
Conv. Total (cfs)	7984.2	Conv. (cfs)	302.8	7655.0
26.3				
Length wtd. (ft)	100.22	wetted Per. (ft)	44.01	27.77
55.21				
Min Ch El (ft)	648.00	Shear (lb/sq ft)	0.12	0.62
0.02				
Alpha	1.71	Stream Power (lb/ft s)	154.50	-13.50
21.00				
Frctn Loss (ft)	0.42	Cum Volume (acre-ft)	0.04	0.31
0.01				
C & E Loss (ft)	0.02	Cum SA (acres)	0.10	0.10
0.06				

WestTribFlow.rep

Warning: Divided flow computed for this cross-section.
 Note: Multiple critical depths were found at this location. The critical depth with the lowest, valid, energy was used.

CROSS SECTION OUTPUT Profile #PF 26

		Element	Left OB	Channel
E.G. Elev (ft)	653.56			
Right OB				
Vel Head (ft)	0.48	wt. n-val.	0.080	0.030
0.080				
W.S. Elev (ft)	653.08	Reach Len. (ft)	112.00	100.00
97.00				
Crit w.s. (ft)	652.01	Flow Area (sq ft)	31.23	81.76
17.74				
E.G. slope (ft/ft)	0.003206	Area (sq ft)	47.41	81.76
17.74				
Q Total (cfs)	500.00	Flow (cfs)	25.77	467.90
6.33				
Top width (ft)	208.51	Top width (ft)	90.98	25.50
92.03				
Vel Total (ft/s)	3.82	Avg. vel. (ft/s)	0.83	5.72
0.36				
Max Chl Dpth (ft)	5.08	Hydr. Depth (ft)	0.69	3.21
0.19				
Conv. Total (cfs)	8830.0	Conv. (cfs)	455.1	8263.0
111.8				
Length wtd. (ft)	100.29	wetted Per. (ft)	45.33	28.05
92.04				
Min Ch El (ft)	648.00	Shear (lb/sq ft)	0.14	0.58
0.04				
Alpha	2.10	Stream Power (lb/ft s)	154.50	-13.50
21.00				
Frctn Loss (ft)	0.40	cum volume (acre-ft)	0.06	0.32
0.02				
C & E Loss (ft)	0.03	cum SA (acres)	0.12	0.10
0.10				

Warning: Divided flow computed for this cross-section.
 Note: Multiple critical depths were found at this location. The critical depth with the lowest, valid, energy was used.

CROSS SECTION OUTPUT Profile #PF 27

		Element	Left OB	Channel
E.G. Elev (ft)	653.65			
Right OB				
Vel Head (ft)	0.47	wt. n-val.	0.080	0.030
0.080				
W.S. Elev (ft)	653.18	Reach Len. (ft)	112.00	100.00
97.00				
Crit w.s. (ft)	652.10	Flow Area (sq ft)	35.86	84.34
27.88				
E.G. slope (ft/ft)	0.003066	Area (sq ft)	57.29	84.34
27.88				
Q Total (cfs)	525.00	Flow (cfs)	31.43	481.87
11.70				
Top width (ft)	236.87	Top width (ft)	104.43	25.50

westTribFlow.rep

106.94				
Vel Total (ft/s)	3.55	Avg. Vel. (ft/s)	0.88	5.71
0.42				
Max Chl Dpth (ft)	5.18	Hydr. Depth (ft)	0.77	3.31
0.26				
Conv. Total (cfs)	9481.0	Conv. (cfs)	567.7	8702.0
211.3				
Length wtd. (ft)	100.44	wetted Per. (ft)	46.37	28.05
106.95				
Min Ch El (ft)	648.00	Shear (lb/sq ft)	0.15	0.58
0.05				
Alpha	2.39	Stream Power (lb/ft s)	154.50	-13.50
21.00				
Frctn Loss (ft)	0.37	Cum Volume (acre-ft)	0.15	0.33
0.03				
C & E Loss (ft)	0.02	Cum SA (acres)	0.57	0.11
0.12				

Warning: Divided flow computed for this cross-section.
 Note: Multiple critical depths were found at this location. The critical depth with the lowest, valid, energy was used.

CROSS SECTION OUTPUT Profile #PF 28

E.G. Elev (ft)	653.73	Element	Left OB	Channel
Right OB				
Vel Head (ft)	0.45	wt. n-Val.	0.080	0.030
0.080				
W.S. Elev (ft)	653.29	Reach Len. (ft)	112.00	100.00
97.00				
Crit w.s. (ft)	652.19	Flow Area (sq ft)	41.00	87.14
40.01				
E.G. Slope (ft/ft)	0.002872	Area (sq ft)	69.54	87.14
40.01				
Q Total (cfs)	550.00	Flow (cfs)	37.60	492.44
19.96				
Top Width (ft)	257.27	Top Width (ft)	119.02	25.50
112.75				
Vel Total (ft/s)	3.27	Avg. Vel. (ft/s)	0.92	5.65
0.50				
Max Chl Dpth (ft)	5.29	Hydr. Depth (ft)	0.86	3.42
0.35				
Conv. Total (cfs)	10262.3	Conv. (cfs)	701.6	9188.3
372.4				
Length wtd. (ft)	100.54	wetted Per. (ft)	47.48	28.05
112.75				
Min Ch El (ft)	648.00	Shear (lb/sq ft)	0.15	0.56
0.06				
Alpha	2.68	Stream Power (lb/ft s)	154.50	-13.50
21.00				
Frctn Loss (ft)	0.35	Cum Volume (acre-ft)	0.23	0.35
0.04				
C & E Loss (ft)	0.02	Cum SA (acres)	0.69	0.11
0.13				

Warning: Divided flow computed for this cross-section.
 Note: Multiple critical depths were found at this location. The critical depth with the lowest, valid, energy was used.

WestTribClow.rep

CROSS SECTION OUTPUT Profile #PF 29

		Element	Left OB	Channel
E.G. Elev (ft)	653.75			
Right OB				
Vel Head (ft)	0.54	wt. n-Val.	0.080	0.030
0.080				
W.S. Elev (ft)	653.20	Reach Len. (ft)	112.00	100.00
97.00				
Crit w.s. (ft)	652.27	Flow Area (sq ft)	36.98	84.95
30.49				
E.G. slope (ft/ft)	0.003554	Area (sq ft)	59.84	84.95
30.49				
Q Total (cfs)	575.00	Flow (cfs)	35.53	525.08
14.38				
Top width (ft)	242.78	Top width (ft)	107.64	25.50
109.65				
Vel Total (ft/s)	3.77	Avg. vel. (ft/s)	0.96	6.18
0.47				
Max Chl Dpth (ft)	5.20	Hydr. Depth (ft)	0.79	3.33
0.28				
Conv. Total (cfs)	9645.3	Conv. (cfs)	596.1	8808.0
241.3				
Length wtd. (ft)	100.58	wetted Per. (ft)	46.61	28.05
109.65				
Min Ch El (ft)	648.00	Shear (lb/sq ft)	0.18	0.67
0.06				
Alpha	2.46	Stream Power (lb/ft s)	154.50	-13.50
21.00				
Frctn Loss (ft)	0.35	Cum volume (acre-ft)	0.34	0.36
0.15				
C & E Loss (ft)	0.01	Cum SA (acres)	0.77	0.11
0.37				

Warning: Divided flow computed for this cross-section.

Note: Multiple critical depths were found at this location. The critical depth with the lowest, valid, energy was used.

CROSS SECTION OUTPUT Profile #PF 30

		Element	Left OB	Channel
E.G. Elev (ft)	653.82			
Right OB				
Vel Head (ft)	0.53	wt. n-Val.	0.080	0.030
0.080				
W.S. Elev (ft)	653.29	Reach Len. (ft)	112.00	100.00
97.00				
Crit w.s. (ft)	652.37	Flow Area (sq ft)	41.01	87.14
40.04				
E.G. slope (ft/ft)	0.003417	Area (sq ft)	69.58	87.14
40.04				
Q Total (cfs)	600.00	Flow (cfs)	41.03	537.17
21.80				
Top width (ft)	257.32	Top width (ft)	119.06	25.50
112.76				
Vel Total (ft/s)	3.57	Avg. vel. (ft/s)	1.00	6.16
0.54				
Max Chl Dpth (ft)	5.29	Hydr. Depth (ft)	0.87	3.42
0.36				
Conv. Total (cfs)	10264.5	Conv. (cfs)	702.0	9189.6

WestTribClow.rep

372.9					
Length Wtd. (ft)	100.67	Wetted Per. (ft)	47.49	28.05	
112.77					
Min Ch El (ft)	648.00	Shear (lb/sq ft)	0.18	0.66	
0.08					
Alpha	2.68	Stream Power (lb/ft s)	154.50	-13.50	
21.00					
Frctn Loss (ft)	0.32	Cum Volume (acre-ft)	0.44	0.38	
0.19					
C & E Loss (ft)	0.02	Cum SA (acres)	0.80	0.11	
0.42					

Warning: Divided flow computed for this cross-section.

Note: Multiple critical depths were found at this location. The critical depth with the lowest, valid, energy was used.

CROSS SECTION

RIVER: WestTribClow
 REACH: WestTribClow RS: 1100

INPUT

Description: Sta 11+00

Station Elevation Data num= 33

Sta	Elev	Sta	Elev	Sta	Elev	Sta	Elev	Sta	Elev
-292	654	-261.5	653	-239.5	652.6	-183.5	652.3	-138	652.5
-93.5	652.8	-70	652.4	-50.5	652	-9.5	652.6	-8.5	652
-7	651	-5.5	650	-4	649	-2.5	648	0	647.4
4.5	648	8	649	10	650	12	651	14	652
16	653	18	653.4	19.5	653	20.5	652.7	24	653
38	653	43	652.4	61	652	62.5	651.8	64	652
90.5	652.5	141	652.6	150	653				

Manning's n Values num= 3

Sta	n Val	Sta	n Val	Sta	n Val
-292	.08	-9.5	.03	16	.08

Bank Sta: Left	Right	Lengths: Left	Channel	Right	Coeff Contr.	Expan.
-9.5	16	112	100	97	.1	.3
Ineffective Flow	num=	2				
Sta L	Sta R	Elev	Permanent			
-292	-86	658.1	F			
188	150	658.6	F			
Left Levee	Station=	-9.5	Elevation=	652.5		
Right Levee	Station=	18	Elevation=	652.8		

CROSS SECTION OUTPUT Profile #PF 1

E.G. Elev (ft)	648.37	Element	Left OB	Channel
Right OB				
Vel Head (ft)	0.08	wt. n-val.		0.030
w.s. Elev (ft)	648.29	Reach Len. (ft)	112.00	100.00
97.00				
Crit w.s. (ft)	648.11	Flow Area (sq ft)		4.36
E.G. slope (ft/ft)	0.005375	Area (sq ft)		4.36
Q Total (cfs)	10.00	Flow (cfs)		10.00

westTribClow.rep

Top width (ft)	8.46	Top width (ft)	8.46
Vel Total (ft/s)	2.29	Avg. Vel. (ft/s)	2.29
Max Chl Dpth (ft)	0.89	Hydr. Depth (ft)	0.52
Conv. Total (cfs)	136.4	Conv. (cfs)	136.4
Length wtd. (ft)	100.00	wetted Per. (ft)	8.70
Min Ch El (ft)	647.40	Shear (lb/sq ft)	0.17
Alpha 18.00	1.00	Stream Power (lb/ft s)	150.00 -9.50
Frctn Loss (ft)	0.92	Cum volume (acre-ft)	0.01
C & E Loss (ft)	0.02	Cum SA (acres)	0.02

Warning: The conveyance ratio (upstream conveyance divided by downstream conveyance) is less than 0.7 or greater than 1.4.

This may indicate the need for additional cross sections.

Note: Multiple critical depths were found at this location. The critical depth with the lowest, valid, energy was used.

CROSS SECTION OUTPUT Profile #PF 2

E.G. Elev (ft)	648.71	Element	Left OB	Channel
Right OB Vel Head (ft)	0.13	wt. n-val.		0.030
W.S. Elev (ft)	648.58	Reach Len. (ft)	112.00	100.00
97.00 Crit w.s. (ft)	648.34	Flow Area (sq ft)		7.02
E.G. slope (ft/ft)	0.005509	Area (sq ft)		7.02
Q Total (cfs)	20.00	Flow (cfs)		20.00
Top width (ft)	9.91	Top width (ft)		9.91
Vel Total (ft/s)	2.85	Avg. Vel. (ft/s)		2.85
Max Chl Dpth (ft)	1.18	Hydr. Depth (ft)		0.71
Conv. Total (cfs)	269.5	Conv. (cfs)		269.5
Length wtd. (ft)	100.00	wetted Per. (ft)		10.28
Min Ch El (ft)	647.40	Shear (lb/sq ft)		0.23
Alpha 18.00	1.00	Stream Power (lb/ft s)	150.00	-9.50
Frctn Loss (ft)	0.89	Cum volume (acre-ft)		0.01
C & E Loss (ft)	0.02	Cum SA (acres)		0.02

WestTribClow.rep

Warning: The conveyance ratio (upstream conveyance divided by downstream conveyance) is less than 0.7 or greater than 1.4.

This may indicate the need for additional cross sections.

Note: Multiple critical depths were found at this location. The critical depth with the lowest, valid, energy was used.

CROSS SECTION OUTPUT Profile #PF 3

E.G. Elev (ft)	648.96	Element	Left OB	Channel
Right OB				
Vel Head (ft)	0.16	wt. n-val.		0.030
W.S. Elev (ft)	648.80	Reach Len. (ft)	112.00	100.00
97.00				
Crit w.s. (ft)	648.52	Flow Area (sq ft)		9.31
E.G. slope (ft/ft)	0.005584	Area (sq ft)		9.31
Q Total (cfs)	30.00	Flow (cfs)		30.00
Top width (ft)	11.01	Top width (ft)		11.01
Vel Total (ft/s)	3.22	Avg. vel. (ft/s)		3.22
Max Chl Dpth (ft)	1.40	Hydr. Depth (ft)		0.85
Conv. Total (cfs)	401.5	Conv. (cfs)		401.5
Length wtd. (ft)	100.00	wetted Per. (ft)		11.47
Min Ch El (ft)	647.40	Shear (lb/sq ft)		0.28
Alpha	1.00	Stream Power (lb/ft s)	150.00	-9.50
18.00				
Frctn Loss (ft)	0.89	cum volume (acre-ft)		0.02
C & E Loss (ft)	0.02	cum SA (acres)		0.02

Warning: The conveyance ratio (upstream conveyance divided by downstream conveyance) is less than 0.7 or greater than 1.4.

This may indicate the need for additional cross sections.

Note: Multiple critical depths were found at this location. The critical depth with the lowest, valid, energy was used.

CROSS SECTION OUTPUT Profile #PF 4

E.G. Elev (ft)	649.17	Element	Left OB	Channel
Right OB				
Vel Head (ft)	0.19	wt. n-val.		0.030
W.S. Elev (ft)	648.98	Reach Len. (ft)	112.00	100.00
97.00				
Crit w.s. (ft)	648.68	Flow Area (sq ft)		11.32
E.G. slope (ft/ft)	0.005768	Area (sq ft)		11.32
Q Total (cfs)	40.00	Flow (cfs)		40.00

westTribClow.rep

Top width (ft)	11.88	Top width (ft)	11.88
Vel Total (ft/s)	3.53	Avg. Vel. (ft/s)	3.53
Max Chl Dpth (ft)	1.58	Hydr. Depth (ft)	0.95
Conv. Total (cfs)	526.7	Conv. (cfs)	526.7
Length wtd. (ft)	100.00	wetted Per. (ft)	12.42
Min Ch El (ft)	647.40	Shear (lb/sq ft)	0.33
Alpha 18.00	1.00	Stream Power (lb/ft s)	150.00
Frctn Loss (ft)	0.90	Cum volume (acre-ft)	0.02
C & E Loss (ft)	0.02	Cum SA (acres)	0.03

Warning: The conveyance ratio (upstream conveyance divided by downstream conveyance) is less than 0.7 or greater than 1.4.

This may indicate the need for additional cross sections.

Note: Multiple critical depths were found at this location. The critical depth with the lowest, valid, energy was used.

CROSS SECTION OUTPUT Profile #PF 5

E.G. Elev (ft)	649.35	Element	Left OB	Channel
Right OB Vel Head (ft)	0.23	wt. n-val.		0.030
W.S. Elev (ft)	649.12	Reach Len. (ft)	112.00	100.00
97.00 Crit w.s. (ft)	648.81	Flow Area (sq ft)		13.09
E.G. slope (ft/ft)	0.005926	Area (sq ft)		13.09
Q Total (cfs)	50.00	Flow (cfs)		50.00
Top width (ft)	12.43	Top width (ft)		12.43
Vel Total (ft/s)	3.82	Avg. Vel. (ft/s)		3.82
Max Chl Dpth (ft)	1.72	Hydr. Depth (ft)		1.05
Conv. Total (cfs)	649.5	Conv. (cfs)		649.5
Length wtd. (ft)	100.00	wetted Per. (ft)		13.05
Min Ch El (ft)	647.40	Shear (lb/sq ft)		0.37
Alpha 18.00	1.00	Stream Power (lb/ft s)	150.00	-9.50
Frctn Loss (ft)	0.89	Cum volume (acre-ft)		0.03
C & E Loss (ft)	0.02	Cum SA (acres)		0.03

WestTribFlow.rep

Warning: The conveyance ratio (upstream conveyance divided by downstream conveyance) is less than 0.7 or greater than 1.4.

This may indicate the need for additional cross sections.

Note: Multiple critical depths were found at this location. The critical depth with the lowest, valid, energy was used.

CROSS SECTION OUTPUT Profile #PF 6

E.G. Elev (ft)	649.51	Element	Left OB	Channel
Right OB Vel Head (ft)	0.25	wt. n-val.		0.030
W.S. Elev (ft)	649.26	Reach Len. (ft)	112.00	100.00
97.00 Crit w.s. (ft)	648.94	Flow Area (sq ft)		14.82
E.G. slope (ft/ft)	0.005958	Area (sq ft)		14.82
Q Total (cfs)	60.00	Flow (cfs)		60.00
Top width (ft)	12.90	Top width (ft)		12.90
Vel Total (ft/s)	4.05	Avg. vel. (ft/s)		4.05
Max Chl Dpth (ft)	1.86	Hydr. Depth (ft)		1.15
Conv. Total (cfs)	777.3	Conv. (cfs)		777.3
Length wtd. (ft)	100.00	wetted Per. (ft)		13.60
Min Ch El (ft)	647.40	Shear (lb/sq ft)		0.41
Alpha	1.00	Stream Power (lb/ft s)	150.00	-9.50
18.00 Frctn Loss (ft)	0.89	Cum volume (acre-ft)		0.03
C & E Loss (ft)	0.02	Cum SA (acres)		0.03

Warning: The conveyance ratio (upstream conveyance divided by downstream conveyance) is less than 0.7 or greater than 1.4.

This may indicate the need for additional cross sections.

Note: Multiple critical depths were found at this location. The critical depth with the lowest, valid, energy was used.

CROSS SECTION OUTPUT Profile #PF 7

E.G. Elev (ft)	649.66	Element	Left OB	Channel
Right OB Vel Head (ft)	0.28	wt. n-val.		0.030
W.S. Elev (ft)	649.38	Reach Len. (ft)	112.00	100.00
97.00 Crit w.s. (ft)	649.06	Flow Area (sq ft)		16.43
E.G. slope (ft/ft)	0.006029	Area (sq ft)		16.43
Q Total (cfs)	70.00	Flow (cfs)		70.00

westTribClow.rep

Top width (ft)	13.33	Top width (ft)	13.33
Vel Total (ft/s)	4.26	Avg. Vel. (ft/s)	4.26
Max Chl Dpth (ft)	1.98	Hydr. Depth (ft)	1.23
Conv. Total (cfs)	901.5	Conv. (cfs)	901.5
Length Wtd. (ft)	100.00	wetted Per. (ft)	14.09
Min Ch El (ft)	647.40	Shear (lb/sq ft)	0.44
Alpha 18.00	1.00	Stream Power (lb/ft s)	150.00 -9.50
Frctn Loss (ft)	0.89	Cum volume (acre-ft)	0.03
C & E Loss (ft)	0.02	Cum SA (acres)	0.03

Warning: The conveyance ratio (upstream conveyance divided by downstream conveyance) is less than 0.7 or greater than 1.4.

This may indicate the need for additional cross sections.

Note: Multiple critical depths were found at this location. The critical depth with the lowest, valid, energy was used.

CROSS SECTION OUTPUT Profile #PF 8

E.G. Elev (ft)	649.80	Element	Left OB	Channel
Right OB Vel Head (ft)	0.31	wt. n-val.		0.030
W.S. Elev (ft)	649.50	Reach Len. (ft)	112.00	100.00
97.00 Crit w.s. (ft)	649.16	Flow Area (sq ft)		18.01
E.G. slope (ft/ft)	0.006060	Area (sq ft)		18.01
Q Total (cfs)	80.00	Flow (cfs)		80.00
Top width (ft)	13.74	Top width (ft)		13.74
Vel Total (ft/s)	4.44	Avg. Vel. (ft/s)		4.44
Max Chl Dpth (ft)	2.10	Hydr. Depth (ft)		1.31
Conv. Total (cfs)	1027.7	Conv. (cfs)		1027.7
Length Wtd. (ft)	100.00	wetted Per. (ft)		14.56
Min Ch El (ft)	647.40	Shear (lb/sq ft)		0.47
Alpha 18.00	1.00	Stream Power (lb/ft s)	150.00	-9.50
Frctn Loss (ft)	0.89	Cum volume (acre-ft)		0.04
C & E Loss (ft)	0.02	Cum SA (acres)		0.03

WestTribFlow.rep

Warning: The conveyance ratio (upstream conveyance divided by downstream conveyance) is less than 0.7 or greater than 1.4.

This may indicate the need for additional cross sections.

Note: Multiple critical depths were found at this location. The critical depth with the lowest, valid, energy was used.

CROSS SECTION OUTPUT Profile #PF 9

E.G. Elev (ft)	649.94	Element	Left OB	Channel
Right OB Vel Head (ft)	0.33	wt. n-val.		0.030
W.S. Elev (ft)	649.60	Reach Len. (ft)	112.00	100.00
97.00 Crit w.s. (ft)	649.26	Flow Area (sq ft)		19.50
E.G. slope (ft/ft)	0.006122	Area (sq ft)		19.50
Q Total (cfs)	90.00	Flow (cfs)		90.00
Top width (ft)	14.12	Top width (ft)		14.12
Vel Total (ft/s)	4.62	Avg. vel. (ft/s)		4.62
Max Chl Dpth (ft)	2.20	Hydr. Depth (ft)		1.38
Conv. Total (cfs)	1150.3	Conv. (cfs)		1150.3
Length wtd. (ft)	100.00	wetted Per. (ft)		15.00
Min Ch El (ft)	647.40	Shear (lb/sq ft)		0.50
Alpha	1.00	Stream Power (lb/ft s)	150.00	-9.50
18.00 Frctn Loss (ft)	0.88	Cum volume (acre-ft)		0.04
C & E Loss (ft)	0.03	Cum SA (acres)		0.03

Warning: The conveyance ratio (upstream conveyance divided by downstream conveyance) is less than 0.7 or greater than 1.4.

This may indicate the need for additional cross sections.

Note: Multiple critical depths were found at this location. The critical depth with the lowest, valid, energy was used.

CROSS SECTION OUTPUT Profile #PF 10

E.G. Elev (ft)	650.06	Element	Left OB	Channel
Right OB Vel Head (ft)	0.35	wt. n-val.		0.030
W.S. Elev (ft)	649.71	Reach Len. (ft)	112.00	100.00
97.00 Crit w.s. (ft)	649.35	Flow Area (sq ft)		21.03
E.G. slope (ft/ft)	0.006095	Area (sq ft)		21.03
Q Total (cfs)	100.00	Flow (cfs)		100.00

westTribClow.rep

Top width (ft)	14.49	Top width (ft)	14.49
Vel Total (ft/s)	4.75	Avg. Vel. (ft/s)	4.75
Max Chl Dpth (ft)	2.31	Hydr. Depth (ft)	1.45
Conv. Total (cfs)	1280.9	Conv. (cfs)	1280.9
Length wtd. (ft)	100.00	wetted Per. (ft)	15.43
Min Ch El (ft)	647.40	Shear (lb/sq ft)	0.52
Alpha 18.00	1.00	Stream Power (lb/ft s)	150.00
Frctn Loss (ft)	0.88	Cum volume (acre-ft)	0.04
C & E Loss (ft)	0.03	Cum SA (acres)	0.03

Warning: The conveyance ratio (upstream conveyance divided by downstream conveyance) is less than 0.7 or greater than 1.4.

This may indicate the need for additional cross sections.

Note: Multiple critical depths were found at this location. The critical depth with the lowest, valid, energy was used.

CROSS SECTION OUTPUT Profile #PF 11

E.G. Elev (ft)	650.35	Element	Left OB	Channel
Right OB Vel Head (ft)	0.40	wt. n-val.		0.030
W.S. Elev (ft)	649.95	Reach Len. (ft)	112.00	100.00
97.00 Crit w.s. (ft)	649.57	Flow Area (sq ft)		24.53
E.G. slope (ft/ft)	0.006173	Area (sq ft)		24.53
Q Total (cfs)	125.00	Flow (cfs)		125.00
Top width (ft)	15.31	Top width (ft)		15.31
Vel Total (ft/s)	5.09	Avg. Vel. (ft/s)		5.09
Max Chl Dpth (ft)	2.55	Hydr. Depth (ft)		1.60
Conv. Total (cfs)	1590.9	Conv. (cfs)		1590.9
Length wtd. (ft)	100.00	wetted Per. (ft)		16.38
Min Ch El (ft)	647.40	Shear (lb/sq ft)		0.58
Alpha 18.00	1.00	Stream Power (lb/ft s)	150.00	-9.50
Frctn Loss (ft)	0.87	Cum volume (acre-ft)		0.05
C & E Loss (ft)	0.03	Cum SA (acres)		0.03

WestTribClow.rep

Warning: The conveyance ratio (upstream conveyance divided by downstream conveyance) is less than 0.7 or greater than 1.4.

This may indicate the need for additional cross sections.

Note: Multiple critical depths were found at this location. The critical depth with the lowest, valid, energy was used.

CROSS SECTION OUTPUT Profile #PF 12

E.G. Elev (ft)	650.62	Element	Left OB	Channel
Right OB Vel Head (ft)	0.44	wt. n-val.		0.030
W.S. Elev (ft)	650.18	Reach Len. (ft)	112.00	100.00
97.00 Crit w.s. (ft)	649.75	Flow Area (sq ft)		28.15
E.G. slope (ft/ft)	0.006050	Area (sq ft)		28.15
Q Total (cfs)	150.00	Flow (cfs)		150.00
Top width (ft)	16.12	Top width (ft)		16.12
Vel Total (ft/s)	5.33	Avg. vel. (ft/s)		5.33
Max Chl Dpth (ft)	2.78	Hydr. Depth (ft)		1.75
Conv. Total (cfs)	1928.5	Conv. (cfs)		1928.5
Length wtd. (ft)	100.00	wetted Per. (ft)		17.31
Min Ch El (ft)	647.40	Shear (lb/sq ft)		0.61
Alpha	1.00	Stream Power (lb/ft s)	150.00	-9.50
18.00 Frctn Loss (ft)	0.86	Cum volume (acre-ft)		0.06
C & E Loss (ft)	0.03	Cum SA (acres)		0.03

Warning: The conveyance ratio (upstream conveyance divided by downstream conveyance) is less than 0.7 or greater than 1.4.

This may indicate the need for additional cross sections.

Note: Multiple critical depths were found at this location. The critical depth with the lowest, valid, energy was used.

CROSS SECTION OUTPUT Profile #PF 13

E.G. Elev (ft)	650.86	Element	Left OB	Channel
Right OB Vel Head (ft)	0.48	wt. n-val.		0.030
W.S. Elev (ft)	650.37	Reach Len. (ft)	112.00	100.00
97.00 Crit w.s. (ft)	649.94	Flow Area (sq ft)		31.39
E.G. slope (ft/ft)	0.006081	Area (sq ft)		31.39
Q Total (cfs)	175.00	Flow (cfs)		175.00

WestTribClow.rep

Top width (ft)	16.81	Top width (ft)	16.81
Vel Total (ft/s)	5.58	Avg. Vel. (ft/s)	5.58
Max Chl Dpth (ft)	2.97	Hydr. Depth (ft)	1.87
Conv. Total (cfs)	2244.1	Conv. (cfs)	2244.1
Length wtd. (ft)	100.00	wetted Per. (ft)	18.10
Min Ch El (ft)	647.40	Shear (lb/sq ft)	0.66
Alpha 18.00	1.00	Stream Power (lb/ft s)	150.00 -9.50
Frctn Loss (ft)	0.85	Cum volume (acre-ft)	0.06
C & E Loss (ft)	0.04	Cum SA (acres)	0.04

Warning: The conveyance ratio (upstream conveyance divided by downstream conveyance) is less than 0.7 or greater than 1.4.

This may indicate the need for additional cross sections.

Note: Multiple critical depths were found at this location. The critical depth with the lowest, valid, energy was used.

CROSS SECTION OUTPUT Profile #PF 14

E.G. Elev (ft)	651.08	Element	Left OB	Channel
Right OB Vel Head (ft)	0.52	wt. n-val.		0.030
W.S. Elev (ft)	650.57	Reach Len. (ft)	112.00	100.00
97.00 Crit w.s. (ft)	650.10	Flow Area (sq ft)		34.69
E.G. slope (ft/ft)	0.006022	Area (sq ft)		34.69
Q Total (cfs)	200.00	Flow (cfs)		200.00
Top width (ft)	17.48	Top width (ft)		17.48
Vel Total (ft/s)	5.77	Avg. Vel. (ft/s)		5.77
Max Chl Dpth (ft)	3.17	Hydr. Depth (ft)		1.98
Conv. Total (cfs)	2577.2	Conv. (cfs)		2577.2
Length wtd. (ft)	100.00	wetted Per. (ft)		18.88
Min Ch El (ft)	647.40	Shear (lb/sq ft)		0.69
Alpha 18.00	1.00	Stream Power (lb/ft s)	150.00	-9.50
Frctn Loss (ft)	0.84	Cum volume (acre-ft)		0.07
C & E Loss (ft)	0.04	Cum SA (acres)		0.04

WestTribFlow.rep

Warning: The conveyance ratio (upstream conveyance divided by downstream conveyance) is less than 0.7 or greater than 1.4.

This may indicate the need for additional cross sections.

Note: Multiple critical depths were found at this location. The critical depth with the lowest, valid, energy was used.

CROSS SECTION OUTPUT Profile #PF 15

E.G. Elev (ft)	651.29	Element	Left OB	Channel
Right OB				
Vel Head (ft)	0.55	wt. n-val.		0.030
W.S. Elev (ft)	650.75	Reach Len. (ft)	112.00	100.00
97.00				
Crit w.s. (ft)	650.26	Flow Area (sq ft)		37.92
E.G. slope (ft/ft)	0.005959	Area (sq ft)		37.92
Q Total (cfs)	225.00	Flow (cfs)		225.00
Top width (ft)	18.12	Top width (ft)		18.12
vel Total (ft/s)	5.93	Avg. vel. (ft/s)		5.93
Max Chl Dpth (ft)	3.35	Hydr. Depth (ft)		2.09
Conv. Total (cfs)	2914.8	Conv. (cfs)		2914.8
Length wtd. (ft)	100.00	wetted Per. (ft)		19.61
Min Ch El (ft)	647.40	Shear (lb/sq ft)		0.72
Alpha	1.00	Stream Power (lb/ft s)	150.00	-9.50
18.00				
Frctn Loss (ft)	0.83	Cum volume (acre-ft)		0.08
C & E Loss (ft)	0.04	Cum SA (acres)		0.04

Warning: The conveyance ratio (upstream conveyance divided by downstream conveyance) is less than 0.7 or greater than 1.4.

This may indicate the need for additional cross sections.

Note: Multiple critical depths were found at this location. The critical depth with the lowest, valid, energy was used.

CROSS SECTION OUTPUT Profile #PF 16

E.G. Elev (ft)	651.50	Element	Left OB	Channel
Right OB				
Vel Head (ft)	0.57	wt. n-val.		0.030
W.S. Elev (ft)	650.92	Reach Len. (ft)	112.00	100.00
97.00				
Crit w.s. (ft)	650.41	Flow Area (sq ft)		41.16
E.G. slope (ft/ft)	0.005870	Area (sq ft)		41.16
Q Total (cfs)	250.00	Flow (cfs)		250.00

WestTribClow.rep

Top width (ft)	18.73	Top width (ft)	18.73
Vel Total (ft/s)	6.07	Avg. Vel. (ft/s)	6.07
Max Chl Dpth (ft)	3.52	Hydr. Depth (ft)	2.20
Conv. Total (cfs)	3263.0	Conv. (cfs)	3263.0
Length wtd. (ft)	100.00	wetted Per. (ft)	20.32
Min Ch El (ft)	647.40	Shear (lb/sq ft)	0.74
Alpha 18.00	1.00	Stream Power (lb/ft s)	150.00
Frctn Loss (ft)	0.82	Cum volume (acre-ft)	0.08
C & E Loss (ft)	0.04	Cum SA (acres)	0.04

Warning: The conveyance ratio (upstream conveyance divided by downstream conveyance) is less than 0.7 or greater than 1.4.

This may indicate the need for additional cross sections.

Note: Multiple critical depths were found at this location. The critical depth with the lowest, valid, energy was used.

CROSS SECTION OUTPUT Profile #PF 17

E.G. Elev (ft)	651.69	Element	Left OB	Channel
Right OB Vel Head (ft)	0.60	wt. n-val.		0.030
W.S. Elev (ft)	651.09	Reach Len. (ft)	112.00	100.00
97.00 Crit w.s. (ft)	650.56	Flow Area (sq ft)		44.38
E.G. slope (ft/ft)	0.005774	Area (sq ft)		44.38
Q Total (cfs)	275.00	Flow (cfs)		275.00
Top width (ft)	19.32	Top width (ft)		19.32
Vel Total (ft/s)	6.20	Avg. Vel. (ft/s)		6.20
Max Chl Dpth (ft)	3.69	Hydr. Depth (ft)		2.30
Conv. Total (cfs)	3619.1	Conv. (cfs)		3619.1
Length wtd. (ft)	100.00	wetted Per. (ft)		21.01
Min Ch El (ft)	647.40	Shear (lb/sq ft)		0.76
Alpha 18.00	1.00	Stream Power (lb/ft s)	150.00	-9.50
Frctn Loss (ft)	0.81	Cum volume (acre-ft)		0.09
C & E Loss (ft)	0.05	Cum SA (acres)		0.04

WestTribFlow.rep

Warning: The conveyance ratio (upstream conveyance divided by downstream conveyance) is less than 0.7 or greater than 1.4.

This may indicate the need for additional cross sections.

Note: Multiple critical depths were found at this location. The critical depth with the lowest, valid, energy was used.

CROSS SECTION OUTPUT Profile #PF 18

E.G. Elev (ft)	651.87	Element	Left OB	Channel
Right OB Vel Head (ft)	0.62	wt. n-val.		0.030
W.S. Elev (ft)	651.25	Reach Len. (ft)	112.00	100.00
97.00 Crit w.s. (ft)	650.69	Flow Area (sq ft)		47.50
E.G. slope (ft/ft)	0.005703	Area (sq ft)		47.50
Q Total (cfs)	300.00	Flow (cfs)		300.00
Top width (ft)	19.88	Top width (ft)		19.88
vel Total (ft/s)	6.32	Avg. vel. (ft/s)		6.32
Max Chl Dpth (ft)	3.85	Hydr. Depth (ft)		2.39
Conv. Total (cfs)	3972.5	Conv. (cfs)		3972.5
Length wtd. (ft)	100.00	wetted Per. (ft)		21.65
Min Ch El (ft)	647.40	Shear (lb/sq ft)		0.78
Alpha	1.00	Stream Power (lb/ft s)	150.00	-9.50
18.00 Frctn Loss (ft)	0.80	cum volume (acre-ft)		0.10
C & E Loss (ft)	0.05	cum SA (acres)		0.04

Warning: The conveyance ratio (upstream conveyance divided by downstream conveyance) is less than 0.7 or greater than 1.4.

This may indicate the need for additional cross sections.

Note: Multiple critical depths were found at this location. The critical depth with the lowest, valid, energy was used.

CROSS SECTION OUTPUT Profile #PF 19

E.G. Elev (ft)	652.05	Element	Left OB	Channel
Right OB Vel Head (ft)	0.64	wt. n-val.		0.030
W.S. Elev (ft)	651.41	Reach Len. (ft)	112.00	100.00
97.00 Crit w.s. (ft)	650.81	Flow Area (sq ft)		50.62
E.G. slope (ft/ft)	0.005625	Area (sq ft)		50.62
Q Total (cfs)	325.00	Flow (cfs)		325.00

westTribClow.rep

Top Width (ft)	20.42	Top Width (ft)	20.42
Vel Total (ft/s)	6.42	Avg. Vel. (ft/s)	6.42
Max Chl Dpth (ft)	4.01	Hydr. Depth (ft)	2.48
Conv. Total (cfs)	4333.4	Conv. (cfs)	4333.4
Length wtd. (ft)	100.00	wetted Per. (ft)	22.27
Min Ch El (ft)	647.40	Shear (lb/sq ft)	0.80
Alpha	1.00	Stream Power (lb/ft s)	150.00
18.00			-9.50
Frctn Loss (ft)	0.79	cum volume (acre-ft)	0.10
C & E Loss (ft)	0.05	cum SA (acres)	0.04

Warning: The velocity head has changed by more than 0.5 ft (0.15 m). This may indicate the need for additional cross sections.
 Warning: The conveyance ratio (upstream conveyance divided by downstream conveyance) is less than 0.7 or greater than 1.4.

This may indicate the need for additional cross sections.

Note: Multiple critical depths were found at this location. The critical depth with the lowest, valid, energy was used.

CROSS SECTION OUTPUT Profile #PF 20

E.G. Elev (ft)	652.22	Element	Left OB	Channel
Right OB				
Vel Head (ft)	0.66	wt. n-val.		0.030
W.S. Elev (ft)	651.56	Reach Len. (ft)	112.00	100.00
97.00				
Crit W.S. (ft)	650.93	Flow Area (sq ft)		53.73
E.G. Slope (ft/ft)	0.005540	Area (sq ft)		53.73
Q Total (cfs)	350.00	Flow (cfs)		350.00
Top Width (ft)	20.95	Top Width (ft)		20.95
Vel Total (ft/s)	6.51	Avg. Vel. (ft/s)		6.51
Max Chl Dpth (ft)	4.16	Hydr. Depth (ft)		2.56
Conv. Total (cfs)	4702.2	Conv. (cfs)		4702.2
Length wtd. (ft)	100.00	wetted Per. (ft)		22.88
Min Ch El (ft)	647.40	Shear (lb/sq ft)		0.81
Alpha	1.00	Stream Power (lb/ft s)	150.00	-9.50
18.00				
Frctn Loss (ft)	0.78	cum volume (acre-ft)		0.11
C & E Loss (ft)	0.05	cum SA (acres)		0.04

WestTribClow.rep

Warning: The velocity head has changed by more than 0.5 ft (0.15 m). This may indicate the need for additional cross sections.
 Warning: The conveyance ratio (upstream conveyance divided by downstream conveyance) is less than 0.7 or greater than 1.4.
 This may indicate the need for additional cross sections.
 Note: Multiple critical depths were found at this location. The critical depth with the lowest, valid, energy was used.

CROSS SECTION OUTPUT Profile #PF 21

E.G. Elev (ft)	652.38	Element	Left OB	Channel
Right OB				
Vel Head (ft)	0.68	wt. n-val.		0.030
w.s. Elev (ft)	651.71	Reach Len. (ft)	112.00	100.00
97.00				
Crit w.s. (ft)	651.06	Flow Area (sq ft)		56.86
E.G. Slope (ft/ft)	0.005450	Area (sq ft)		56.86
Q Total (cfs)	375.00	Flow (cfs)		375.00
Top width (ft)	21.47	Top width (ft)		21.47
Vel Total (ft/s)	6.59	Avg. Vel. (ft/s)		6.59
Max Chl Dpth (ft)	4.30	Hydr. Depth (ft)		2.65
Conv. Total (cfs)	5079.5	Conv. (cfs)		5079.5
Length wtd. (ft)	100.00	wetted Per. (ft)		23.48
Min Ch El (ft)	647.40	Shear (lb/sq ft)		0.82
Alpha	1.00	Stream Power (lb/ft s)	150.00	-9.50
18.00				
Frctn Loss (ft)	0.77	Cum Volume (acre-ft)		0.11
C & E Loss (ft)	0.06	Cum SA (acres)		0.04

Warning: The velocity head has changed by more than 0.5 ft (0.15 m). This may indicate the need for additional cross sections.
 Warning: The conveyance ratio (upstream conveyance divided by downstream conveyance) is less than 0.7 or greater than 1.4.
 This may indicate the need for additional cross sections.
 Note: Multiple critical depths were found at this location. The critical depth with the lowest, valid, energy was used.

CROSS SECTION OUTPUT Profile #PF 22

E.G. Elev (ft)	652.54	Element	Left OB	Channel
Right OB				
Vel Head (ft)	0.69	wt. n-val.		0.030
w.s. Elev (ft)	651.85	Reach Len. (ft)	112.00	100.00

westTribClow.rep

97.00				
Crit W.S. (ft)	651.18	Flow Area (sq ft)		60.04
E.G. Slope (ft/ft)	0.005348	Area (sq ft)		60.04
Q Total (cfs)	400.00	Flow (cfs)		400.00
Top Width (ft)	21.98	Top Width (ft)		21.98
Vel Total (ft/s)	6.66	Avg. Vel. (ft/s)		6.66
Max Chl Dpth (ft)	4.45	Hydr. Depth (ft)		2.73
Conv. Total (cfs)	5469.5	Conv. (cfs)		5469.5
Length wtd. (ft)	100.00	wetted Per. (ft)		24.07
Min Ch El (ft)	647.40	Shear (lb/sq ft)		0.83
Alpha	1.00	Stream Power (lb/ft s)	150.00	-9.50
18.00				
Frctn Loss (ft)	0.76	Cum volume (acre-ft)		0.12
C & E Loss (ft)	0.06	Cum SA (acres)		0.04

Warning: The velocity head has changed by more than 0.5 ft (0.15 m). This may indicate the need for additional cross sections.
 Warning: The conveyance ratio (upstream conveyance divided by downstream conveyance) is less than 0.7 or greater than 1.4.
 This may indicate the need for additional cross sections.
 Note: Multiple critical depths were found at this location. The critical depth with the lowest, valid, energy was used.

CROSS SECTION OUTPUT Profile #PF 23

E.G. Elev (ft)	652.69	Element	Left OB	Channel
Right OB				
Vel Head (ft)	0.71	wt. n-Val.		0.030
W.S. Elev (ft)	651.99	Reach Len. (ft)	112.00	100.00
97.00				
Crit W.S. (ft)	651.29	Flow Area (sq ft)		63.07
E.G. Slope (ft/ft)	0.005279	Area (sq ft)		63.07
Q Total (cfs)	425.00	Flow (cfs)		425.00
Top Width (ft)	22.46	Top Width (ft)		22.46
Vel Total (ft/s)	6.74	Avg. Vel. (ft/s)		6.74
Max Chl Dpth (ft)	4.59	Hydr. Depth (ft)		2.81
Conv. Total (cfs)	5849.2	Conv. (cfs)		5849.2
Length wtd. (ft)	100.00	wetted Per. (ft)		24.62
Min Ch El (ft)	647.40	Shear (lb/sq ft)		0.84

westTribClow.rep				
Alpha	1.00	Stream Power (lb/ft s)	150.00	-9.50
18.00				
Frctn Loss (ft)	0.75	Cum Volume (acre-ft)		0.12
C & E Loss (ft)	0.06	Cum SA (acres)		0.05

Warning: The velocity head has changed by more than 0.5 ft (0.15 m). This may indicate the need for additional cross sections.
Warning: The conveyance ratio (upstream conveyance divided by downstream conveyance) is less than 0.7 or greater than 1.4.
This may indicate the need for additional cross sections.
Note: Multiple critical depths were found at this location. The critical depth with the lowest, valid, energy was used.

CROSS SECTION OUTPUT Profile #PF 24

E.G. Elev (ft)	652.84	Element	Left OB	Channel
Right OB				
Vel Head (ft)	0.72	wt. n-val.		0.030
W.S. Elev (ft)	652.12	Reach Len. (ft)	112.00	100.00
97.00				
Crit w.s. (ft)	651.40	Flow Area (sq ft)		66.17
E.G. Slope (ft/ft)	0.005202	Area (sq ft)		66.17
Q Total (cfs)	450.00	Flow (cfs)		450.00
Top width (ft)	22.95	Top width (ft)		22.95
Vel Total (ft/s)	6.80	Avg. Vel. (ft/s)		6.80
Max Chl Dpth (ft)	4.72	Hydr. Depth (ft)		2.88
Conv. Total (cfs)	6239.3	Conv. (cfs)		6239.3
Length Wtd. (ft)	100.00	wetted Per. (ft)		25.19
Min Ch El (ft)	647.40	Shear (lb/sq ft)		0.85
Alpha	1.00	Stream Power (lb/ft s)	150.00	-9.50
18.00				
Frctn Loss (ft)	0.74	Cum Volume (acre-ft)		0.13
C & E Loss (ft)	0.07	Cum SA (acres)		0.05

Warning: The velocity head has changed by more than 0.5 ft (0.15 m). This may indicate the need for additional cross sections.
Warning: The conveyance ratio (upstream conveyance divided by downstream conveyance) is less than 0.7 or greater than 1.4.
This may indicate the need for additional cross sections.
Note: Multiple critical depths were found at this location. The critical depth with the lowest, valid, energy was used.

CROSS SECTION OUTPUT Profile #PF 25

WestTribClow.rep

E.G. Elev (ft)	652.99	Element	Left OB	Channel
Right OB Vel Head (ft)	0.73	wt. n-val.		0.030
W.S. Elev (ft)	652.26	Reach Len. (ft)	112.00	100.00
97.00 Crit W.S. (ft)	651.50	Flow Area (sq ft)		69.28
E.G. Slope (ft/ft)	0.005121	Area (sq ft)		69.28
Q Total (cfs)	475.00	Flow (cfs)		475.00
Top Width (ft)	23.45	Top Width (ft)		23.45
Vel Total (ft/s)	6.86	Avg. Vel. (ft/s)		6.86
Max Chl Dpth (ft)	4.86	Hydr. Depth (ft)		2.95
Conv. Total (cfs)	6637.7	Conv. (cfs)		6637.7
Length Wtd. (ft)	100.00	wetted Per. (ft)		25.75
Min Ch El (ft)	647.40	Shear (lb/sq ft)		0.86
Alpha 18.00	1.00	Stream Power (lb/ft s)	150.00	-9.50
Frctn Loss (ft)	0.73	Cum volume (acre-ft)		0.14
C & E Loss (ft)	0.07	Cum SA (acres)		0.05

Warning: The velocity head has changed by more than 0.5 ft (0.15 m). This may indicate the need for additional cross sections.
 Warning: The conveyance ratio (upstream conveyance divided by downstream conveyance) is less than 0.7 or greater than 1.4.
 This may indicate the need for additional cross sections.
 Note: Multiple critical depths were found at this location. The critical depth with the lowest, valid, energy was used.

CROSS SECTION OUTPUT Profile #PF 26

E.G. Elev (ft)	653.13	Element	Left OB	Channel
Right OB Vel Head (ft)	0.74	wt. n-val.		0.030
W.S. Elev (ft)	652.39	Reach Len. (ft)	112.00	100.00
97.00 Crit W.S. (ft)	651.59	Flow Area (sq ft)		72.42
E.G. Slope (ft/ft)	0.005035	Area (sq ft)		72.42
Q Total (cfs)	500.00	Flow (cfs)		500.00
Top Width (ft)	23.93	Top Width (ft)		23.93
Vel Total (ft/s)	6.90	Avg. Vel. (ft/s)		6.90
Max Chl Dpth (ft)	4.99	Hydr. Depth (ft)		3.03

westTribClow.rep				
Conv. Total (cfs)	7046.8	Conv. (cfs)		7046.8
Length wtd. (ft)	100.00	wetted Per. (ft)		26.30
Min Ch El (ft)	647.40	Shear (lb/sq ft)		0.87
Alpha	1.00	Stream Power (lb/ft s)	150.00	-9.50
18.00				
Frctn Loss (ft)	0.73	Cum Volume (acre-ft)		0.14
C & E Loss (ft)	0.07	Cum SA (acres)		0.05

Warning: The velocity head has changed by more than 0.5 ft (0.15 m). This may indicate the need for additional cross sections.
Warning: The conveyance ratio (upstream conveyance divided by downstream conveyance) is less than 0.7 or greater than 1.4.
This may indicate the need for additional cross sections.
Note: Multiple critical depths were found at this location. The critical depth with the lowest, valid, energy was used.

CROSS SECTION OUTPUT Profile #PF 27

E.G. Elev (ft)	653.25	Element	Left OB	Channel
Right OB				
Vel Head (ft)	0.69	wt. n-Val.	0.080	0.030
w.s. Elev (ft)	652.56	Reach Len. (ft)	112.00	100.00
97.00				
Crit w.s. (ft)	651.70	Flow Area (sq ft)	18.16	76.40
E.G. Slope (ft/ft)	0.004631	Area (sq ft)	31.51	76.40
Q Total (cfs)	525.00	Flow (cfs)	9.65	515.35
Top width (ft)	192.36	Top width (ft)	167.82	24.54
Vel Total (ft/s)	5.55	Avg. Vel. (ft/s)	0.53	6.75
Max Chl Dpth (ft)	5.16	Hydr. Depth (ft)	0.27	3.11
Conv. Total (cfs)	7714.7	Conv. (cfs)	141.9	7572.8
Length wtd. (ft)	100.11	wetted Per. (ft)	66.55	26.99
Min Ch El (ft)	647.40	Shear (lb/sq ft)	0.08	0.82
Alpha	1.45	Stream Power (lb/ft s)	150.00	-9.50
18.00				
Frctn Loss (ft)	0.69	Cum Volume (acre-ft)	0.04	0.15
C & E Loss (ft)	0.08	Cum SA (acres)	0.22	0.05

Warning: Divided flow computed for this cross-section.
Warning: The velocity head has changed by more than 0.5 ft (0.15 m). This may indicate the need for additional cross sections.
Warning: The conveyance ratio (upstream conveyance divided by downstream conveyance)
Page 196

is less than 0.7 or greater than 1.4.

This may indicate the need for additional cross sections.

Note: Multiple critical depths were found at this location. The critical depth with the lowest, valid, energy was used.

CROSS SECTION OUTPUT Profile #PF 28

E.G. Elev (ft)	653.36	Element	Left OB	Channel
Right OB				
Vel Head (ft)	0.68	wt. n-val.	0.080	0.030
W.S. Elev (ft)	652.68	Reach Len. (ft)	112.00	100.00
97.00				
Crit w.s. (ft)	651.81	Flow Area (sq ft)	27.30	79.51
E.G. Slope (ft/ft)	0.004417	Area (sq ft)	55.61	79.51
Q Total (cfs)	550.00	Flow (cfs)	16.95	533.05
Top width (ft)	234.62	Top width (ft)	209.76	24.86
Vel Total (ft/s)	5.15	Avg. vel. (ft/s)	0.62	6.70
Max chl Dpth (ft)	5.28	Hydr. Depth (ft)	0.36	3.20
Conv. Total (cfs)	8275.5	Conv. (cfs)	255.1	8020.4
Length wtd. (ft)	100.19	wetted Per. (ft)	76.51	27.36
Min Ch El (ft)	647.40	Shear (lb/sq ft)	0.10	0.80
Alpha	1.64	Stream Power (lb/ft s)	150.00	-9.50
18.00				
Frctn Loss (ft)	0.67	Cum Volume (acre-ft)	0.07	0.16
C & E Loss (ft)	0.07	Cum SA (acres)	0.27	0.05

Warning: Divided flow computed for this cross-section.

Warning: The velocity head has changed by more than 0.5 ft (0.15 m). This may indicate the need for additional cross sections.

Warning: The conveyance ratio (upstream conveyance divided by downstream conveyance) is less than 0.7 or greater than 1.4.

This may indicate the need for additional cross sections.

Note: Multiple critical depths were found at this location. The critical depth with the lowest, valid, energy was used.

CROSS SECTION OUTPUT Profile #PF 29

E.G. Elev (ft)	653.39	Element	Left OB	Channel
Right OB				
Vel Head (ft)	0.50	wt. n-val.	0.080	0.030
0.080				
W.S. Elev (ft)	652.89	Reach Len. (ft)	112.00	100.00
97.00				
Crit w.s. (ft)	651.89	Flow Area (sq ft)	43.04	84.67
51.35				
E.G. Slope (ft/ft)	0.003355	Area (sq ft)	103.54	84.67
51.35				

westTribClow.rep				
Q Total (cfs)	575.00	Flow (cfs)	31.55	510.14
33.31				
Top width (ft)	382.33	Top width (ft)	245.76	25.27
111.30				
Vel Total (ft/s)	3.21	Avg. vel. (ft/s)	0.73	6.03
0.65				
Max Chl Dpth (ft)	5.49	Hydr. Depth (ft)	0.56	3.35
0.46				
Conv. Total (cfs)	9927.6	Conv. (cfs)	544.8	8807.7
575.1				
Length wtd. (ft)	100.24	wetted Per. (ft)	76.51	27.82
111.41				
Min Ch El (ft)	647.40	Shear (lb/sq ft)	0.12	0.64
0.10				
Alpha	3.13	Stream Power (lb/ft s)	150.00	-9.50
18.00				
Frctn Loss (ft)	0.56	Cum Volume (acre-ft)	0.13	0.17
0.06				
C & E Loss (ft)	0.09	Cum SA (acres)	0.32	0.05
0.12				

Warning: Divided flow computed for this cross-section.

Warning: The velocity head has changed by more than 0.5 ft (0.15 m). This may indicate the need for additional cross sections.

Warning: The conveyance ratio (upstream conveyance divided by downstream conveyance) is less than 0.7 or greater than 1.4.

This may indicate the need for additional cross sections.

Note: Multiple critical depths were found at this location. The critical depth with the lowest, valid, energy was used.

CROSS SECTION OUTPUT Profile #PF 30

E.G. Elev (ft)	653.47	Element	Left OB	Channel
Right OB				
Vel Head (ft)	0.45	wt. n-Val.	0.080	0.030
0.080				
W.S. Elev (ft)	653.02	Reach Len. (ft)	112.00	100.00
97.00				
Crit w.s. (ft)	651.99	Flow Area (sq ft)	53.23	88.05
66.85				
E.G. Slope (ft/ft)	0.003021	Area (sq ft)	136.75	88.05
66.85				
Q Total (cfs)	600.00	Flow (cfs)	42.67	513.69
43.64				
Top width (ft)	408.77	Top width (ft)	252.60	25.50
130.67				
Vel Total (ft/s)	2.88	Avg. vel. (ft/s)	0.80	5.83
0.65				
Max Chl Dpth (ft)	5.62	Hydr. Depth (ft)	0.70	3.45
0.51				
Conv. Total (cfs)	10915.5	Conv. (cfs)	776.3	9345.3
794.0				
Length wtd. (ft)	100.32	wetted Per. (ft)	76.51	28.07
130.83				
Min Ch El (ft)	647.40	Shear (lb/sq ft)	0.13	0.59
0.10				
Alpha	3.52	Stream Power (lb/ft s)	150.00	-9.50
18.00				
Frctn Loss (ft)	0.53	Cum Volume (acre-ft)	0.18	0.17
0.07				

C & E Loss (ft) 0.15
 WestTribClow.rep Cum SA (acres) 0.09 0.32 0.06

Warning: Divided flow computed for this cross-section.
 Warning: The cross-section end points had to be extended vertically for the computed water surface.
 Warning: The velocity head has changed by more than 0.5 ft (0.15 m). This may indicate the need for additional cross sections.
 Warning: The conveyance ratio (upstream conveyance divided by downstream conveyance) is less than 0.7 or greater than 1.4.
 This may indicate the need for additional cross sections.
 Note: Multiple critical depths were found at this location. The critical depth with the lowest, valid, energy was used.

CROSS SECTION

RIVER: WestTribClow
 REACH: WestTribClow RS: 1000

INPUT

Description: Sta 10+00

Station Elevation Data		num= 27		Sta	Elev	Sta	Elev	Sta	Elev	Sta	Elev
-220.5	653	-166.5	652.7	-85.5	652	-47.5	651.1	-22	652		
-18	652.1	-15	652	-11	652	-10	651	-9.5	650		
-8	648	-2	647	0	646.2	2	647	3.5	648		
6.5	650	8	651	18	652	28	652.1	35	652		
44	651.5	54	652	59	652.1	65.5	652	73.5	651.5		
79	652	92	653								

Manning's n Values		num= 3		Sta	n Val	Sta	n Val
-220.5	.08	-11	.03	18	.08		

Bank Sta:	Left	Right	Lengths:	Left	Channel	Right	Coeff	Contr.	Expan.
	-11	18		0	0	0		.1	.3
Ineffective Flow	num= 1								
Sta L	Sta R	Elev	Permanent						
-220.5	-111		F						
Left Levee	Station=	-18	Elevation=	652.1					
Right Levee	Station=	28	Elevation=	652.1					

CROSS SECTION OUTPUT Profile #PF 1

E.G. Elev (ft)	647.44	Element	Left OB	Channel
Right OB				
Vel Head (ft)	0.24	wt. n-val.		0.030
w.s. Elev (ft)	647.20	Reach Len. (ft)		
Crit w.s. (ft)	647.20	Flow Area (sq ft)		2.53
E.G. Slope (ft/ft)	0.019417	Area (sq ft)		2.53
Q Total (cfs)	10.00	Flow (cfs)		10.00
Top width (ft)	5.48	Top width (ft)		5.48
vel Total (ft/s)	3.95	Avg. vel. (ft/s)		3.95

WestTribClow.rep

Max Chl Dpth (ft)	1.00	Hydr. Depth (ft)		0.46
Conv. Total (cfs)	71.8	Conv. (cfs)		71.8
Length wtd. (ft)		wetted Per. (ft)		5.86
Min Ch El (ft)	646.20	Shear (lb/sq ft)		0.52
Alpha 28.00	1.00	Stream Power (lb/ft s)	92.00	-18.00
Frctn Loss (ft)		Cum Volume (acre-ft)		
C & E Loss (ft)		Cum SA (acres)		

Warning: Slope too steep for slope area to converge during supercritical flow calculations (normal depth is below critical depth).

Water surface set to critical depth.

Note: Multiple critical depths were found at this location. The critical depth with the lowest, valid, energy was used.

CROSS SECTION OUTPUT Profile #PF 2

E.G. Elev (ft)	647.80	Element	Left OB	Channel
Right OB Vel Head (ft)	0.29	wt. n-val.		0.030
w.s. Elev (ft)	647.51	Reach Len. (ft)		
Crit w.s. (ft)	647.51	Flow Area (sq ft)		4.60
E.G. Slope (ft/ft)	0.016950	Area (sq ft)		4.60
Q Total (cfs)	20.00	Flow (cfs)		20.00
Top Width (ft)	7.81	Top Width (ft)		7.81
Vel Total (ft/s)	4.35	Avg. Vel. (ft/s)		4.35
Max Chl Dpth (ft)	1.31	Hydr. Depth (ft)		0.59
Conv. Total (cfs)	153.6	Conv. (cfs)		153.6
Length wtd. (ft)		wetted Per. (ft)		8.32
Min Ch El (ft)	646.20	Shear (lb/sq ft)		0.59
Alpha 28.00	1.00	Stream Power (lb/ft s)	92.00	-18.00
Frctn Loss (ft)		Cum Volume (acre-ft)		
C & E Loss (ft)		Cum SA (acres)		

Warning: Slope too steep for slope area to converge during supercritical flow calculations (normal depth is below critical depth).

Water surface set to critical depth.

Note: Multiple critical depths were found at this location. The critical depth with the lowest, valid, energy was used.

CROSS SECTION OUTPUT Profile #PF 3

E.G. Elev (ft)	648.06	Element	Left OB	Channel
Right OB Vel Head (ft)	0.34	wt. n-Val.		0.030
W.S. Elev (ft)	647.72	Reach Len. (ft)		
Crit W.S. (ft)	647.72	Flow Area (sq ft)		6.40
E.G. Slope (ft/ft)	0.016182	Area (sq ft)		6.40
Q Total (cfs)	30.00	Flow (cfs)		30.00
Top width (ft)	9.38	Top width (ft)		9.38
Vel Total (ft/s)	4.69	Avg. Vel. (ft/s)		4.69
Max Chl Dpth (ft)	1.52	Hydr. Depth (ft)		0.68
Conv. Total (cfs)	235.8	Conv. (cfs)		235.8
Length wtd. (ft)		wetted Per. (ft)		9.96
Min Ch El (ft)	646.20	Shear (lb/sq ft)		0.65
Alpha 28.00	1.00	Stream Power (lb/ft s)	92.00	-18.00
Frctn Loss (ft)		Cum Volume (acre-ft)		
C & E Loss (ft)		Cum SA (acres)		

Warning: Slope too steep for slope area to converge during supercritical flow calculations (normal depth is below critical depth).

Water surface set to critical depth.

Note: Multiple critical depths were found at this location. The critical depth with the lowest, valid, energy was used.

CROSS SECTION OUTPUT Profile #PF 4

E.G. Elev (ft)	648.27	Element	Left OB	Channel
Right OB Vel Head (ft)	0.38	wt. n-Val.		0.030
W.S. Elev (ft)	647.88	Reach Len. (ft)		
Crit W.S. (ft)	647.88	Flow Area (sq ft)		8.05
E.G. Slope (ft/ft)	0.015737	Area (sq ft)		8.05
Q Total (cfs)	40.00	Flow (cfs)		40.00
Top width (ft)	10.62	Top width (ft)		10.62
Vel Total (ft/s)	4.97	Avg. Vel. (ft/s)		4.97

WestTribClow.rep

Max Chl Dpth (ft)	1.68	Hydr. Depth (ft)		0.76
Conv. Total (cfs)	318.9	Conv. (cfs)		318.9
Length wtd. (ft)		wetted Per. (ft)		11.27
Min Ch El (ft)	646.20	Shear (lb/sq ft)		0.70
Alpha	1.00	Stream Power (lb/ft s)	92.00	-18.00
28.00				
Frctn Loss (ft)		Cum Volume (acre-ft)		
C & E Loss (ft)		Cum SA (acres)		

Warning: Slope too steep for slope area to converge during supercritical flow calculations (normal depth is below critical depth).

Water surface set to critical depth.

Note: Multiple critical depths were found at this location. The critical depth with the lowest, valid, energy was used.

CROSS SECTION OUTPUT Profile #PF 5

E.G. Elev (ft)	648.44	Element	Left OB	Channel
Right OB				
Vel Head (ft)	0.42	wt. n-Val.		0.030
w.s. Elev (ft)	648.03	Reach Len. (ft)		
Crit w.s. (ft)	648.03	Flow Area (sq ft)		9.67
E.G. Slope (ft/ft)	0.014980	Area (sq ft)		9.67
Q Total (cfs)	50.00	Flow (cfs)		50.00
Top Width (ft)	11.56	Top Width (ft)		11.56
Vel Total (ft/s)	5.17	Avg. Vel. (ft/s)		5.17
Max Chl Dpth (ft)	1.83	Hydr. Depth (ft)		0.84
Conv. Total (cfs)	408.5	Conv. (cfs)		408.5
Length wtd. (ft)		wetted Per. (ft)		12.28
Min Ch El (ft)	646.20	Shear (lb/sq ft)		0.74
Alpha	1.00	Stream Power (lb/ft s)	92.00	-18.00
28.00				
Frctn Loss (ft)		Cum Volume (acre-ft)		
C & E Loss (ft)		Cum SA (acres)		

Warning: Slope too steep for slope area to converge during supercritical flow calculations (normal depth is below critical depth).

Water surface set to critical depth.

Note: Multiple critical depths were found at this location. The critical depth with the lowest, valid, energy was used.

CROSS SECTION OUTPUT Profile #PF 6

E.G. Elev (ft)	648.60	Element	Left OB	Channel
Right OB Vel Head (ft)	0.47	wt. n-Val.		0.030
W.S. Elev (ft)	648.14	Reach Len. (ft)		
Crit W.S. (ft)	648.14	Flow Area (sq ft)		10.93
E.G. Slope (ft/ft)	0.014846	Area (sq ft)		10.93
Q Total (cfs)	60.00	Flow (cfs)		60.00
Top width (ft)	11.81	Top width (ft)		11.81
Vel Total (ft/s)	5.49	Avg. Vel. (ft/s)		5.49
Max Chl Dpth (ft)	1.94	Hydr. Depth (ft)		0.93
Conv. Total (cfs)	492.4	Conv. (cfs)		492.4
Length wtd. (ft)		wetted Per. (ft)		12.61
Min Ch El (ft)	646.20	Shear (lb/sq ft)		0.80
Alpha 28.00	1.00	Stream Power (lb/ft s)	92.00	-18.00
Frctn Loss (ft)		Cum Volume (acre-ft)		
C & E Loss (ft)		Cum SA (acres)		

Warning: Slope too steep for slope area to converge during supercritical flow calculations (normal depth is below critical depth).

Water surface set to critical depth.

Note: Multiple critical depths were found at this location. The critical depth with the lowest, valid, energy was used.

CROSS SECTION OUTPUT Profile #PF 7

E.G. Elev (ft)	648.75	Element	Left OB	Channel
Right OB Vel Head (ft)	0.51	wt. n-Val.		0.030
W.S. Elev (ft)	648.24	Reach Len. (ft)		
Crit W.S. (ft)	648.24	Flow Area (sq ft)		12.23
E.G. Slope (ft/ft)	0.014383	Area (sq ft)		12.23
Q Total (cfs)	70.00	Flow (cfs)		70.00
Top width (ft)	12.05	Top width (ft)		12.05
Vel Total (ft/s)	5.72	Avg. Vel. (ft/s)		5.72

WestTribClow.rep

Max Chl Dpth (ft)	2.04	Hydr. Depth (ft)		1.02
Conv. Total (cfs)	583.7	Conv. (cfs)		583.7
Length wtd. (ft)		wetted Per. (ft)		12.94
Min Ch El (ft)	646.20	Shear (lb/sq ft)		0.85
Alpha	1.00	Stream Power (lb/ft s)	92.00	-18.00
28.00				
Frctn Loss (ft)		Cum Volume (acre-ft)		
C & E Loss (ft)		Cum SA (acres)		

Warning: Slope too steep for slope area to converge during supercritical flow calculations (normal depth is below critical depth).

Water surface set to critical depth.

Note: Multiple critical depths were found at this location. The critical depth with the lowest, valid, energy was used.

CROSS SECTION OUTPUT Profile #PF 8

E.G. Elev (ft)	648.89	Element	Left OB	Channel
Right OB				
Vel Head (ft)	0.55	wt. n-val.		0.030
w.s. Elev (ft)	648.34	Reach Len. (ft)		
Crit w.s. (ft)	648.34	Flow Area (sq ft)		13.44
E.G. Slope (ft/ft)	0.014163	Area (sq ft)		13.44
Q Total (cfs)	80.00	Flow (cfs)		80.00
Top width (ft)	12.27	Top width (ft)		12.27
Vel Total (ft/s)	5.95	Avg. Vel. (ft/s)		5.95
Max Chl Dpth (ft)	2.14	Hydr. Depth (ft)		1.09
Conv. Total (cfs)	672.2	Conv. (cfs)		672.2
Length wtd. (ft)		wetted Per. (ft)		13.24
Min Ch El (ft)	646.20	Shear (lb/sq ft)		0.90
Alpha	1.00	Stream Power (lb/ft s)	92.00	-18.00
28.00				
Frctn Loss (ft)		Cum Volume (acre-ft)		
C & E Loss (ft)		Cum SA (acres)		

Warning: Slope too steep for slope area to converge during supercritical flow calculations (normal depth is below critical depth).

Water surface set to critical depth.

Note: Multiple critical depths were found at this location. The critical depth with the lowest, valid, energy was used.

CROSS SECTION OUTPUT Profile #PF 9

E.G. Elev (ft)	649.03	Element	Left OB	Channel
Right OB Vel Head (ft)	0.58	wt. n-Val.		0.030
W.S. Elev (ft)	648.45	Reach Len. (ft)		
Crit W.S. (ft)	648.45	Flow Area (sq ft)		14.70
E.G. Slope (ft/ft)	0.013699	Area (sq ft)		14.70
Q Total (cfs)	90.00	Flow (cfs)		90.00
Top width (ft)	12.50	Top width (ft)		12.50
Vel Total (ft/s)	6.12	Avg. Vel. (ft/s)		6.12
Max Chl Dpth (ft)	2.25	Hydr. Depth (ft)		1.18
Conv. Total (cfs)	768.9	Conv. (cfs)		768.9
Length wtd. (ft)		wetted Per. (ft)		13.56
Min Ch El (ft)	646.20	Shear (lb/sq ft)		0.93
Alpha 28.00	1.00	Stream Power (lb/ft s)	92.00	-18.00
Frctn Loss (ft)		Cum Volume (acre-ft)		
C & E Loss (ft)		Cum SA (acres)		

Warning: Slope too steep for slope area to converge during supercritical flow calculations (normal depth is below critical depth).

Water surface set to critical depth.

Note: Multiple critical depths were found at this location. The critical depth with the lowest, valid, energy was used.

CROSS SECTION OUTPUT Profile #PF 10

E.G. Elev (ft)	649.16	Element	Left OB	Channel
Right OB Vel Head (ft)	0.63	wt. n-Val.		0.030
W.S. Elev (ft)	648.53	Reach Len. (ft)		
Crit W.S. (ft)	648.53	Flow Area (sq ft)		15.75
E.G. Slope (ft/ft)	0.013802	Area (sq ft)		15.75
Q Total (cfs)	100.00	Flow (cfs)		100.00
Top width (ft)	12.69	Top width (ft)		12.69
Vel Total (ft/s)	6.35	Avg. Vel. (ft/s)		6.35

WestTribClow.rep

Max Chl Dpth (ft)	2.33	Hydr. Depth (ft)		1.24
Conv. Total (cfs)	851.2	Conv. (cfs)		851.2
Length wtd. (ft)		wetted Per. (ft)		13.81
Min Ch El (ft)	646.20	Shear (lb/sq ft)		0.98
Alpha 28.00	1.00	Stream Power (lb/ft s)	92.00	-18.00
Frctn Loss (ft)		Cum Volume (acre-ft)		
C & E Loss (ft)		Cum SA (acres)		

Warning: Slope too steep for slope area to converge during supercritical flow calculations (normal depth is below critical depth).

Water surface set to critical depth.

Note: Multiple critical depths were found at this location. The critical depth with the lowest, valid, energy was used.

CROSS SECTION OUTPUT Profile #PF 11

E.G. Elev (ft)	649.45	Element	Left OB	Channel
Right OB Vel Head (ft)	0.70	wt. n-val.		0.030
w.s. Elev (ft)	648.75	Reach Len. (ft)		
Crit w.s. (ft)	648.75	Flow Area (sq ft)		18.60
E.G. Slope (ft/ft)	0.013183	Area (sq ft)		18.60
Q Total (cfs)	125.00	Flow (cfs)		125.00
Top width (ft)	13.19	Top width (ft)		13.19
Vel Total (ft/s)	6.72	Avg. Vel. (ft/s)		6.72
Max Chl Dpth (ft)	2.55	Hydr. Depth (ft)		1.41
Conv. Total (cfs)	1088.7	Conv. (cfs)		1088.7
Length wtd. (ft)		wetted Per. (ft)		14.48
Min Ch El (ft)	646.20	Shear (lb/sq ft)		1.06
Alpha 28.00	1.00	Stream Power (lb/ft s)	92.00	-18.00
Frctn Loss (ft)		Cum Volume (acre-ft)		
C & E Loss (ft)		Cum SA (acres)		

Warning: Slope too steep for slope area to converge during supercritical flow calculations (normal depth is below critical depth).

Water surface set to critical depth.

Note: Multiple critical depths were found at this location. The critical depth with the lowest, valid, energy was used.

CROSS SECTION OUTPUT Profile #PF 12

E.G. Elev (ft)	649.72	Element	Left OB	Channel
Right OB Vel Head (ft)	0.79	wt. n-Val.		0.030
W.S. Elev (ft)	648.93	Reach Len. (ft)		
Crit W.S. (ft)	648.93	Flow Area (sq ft)		21.05
E.G. Slope (ft/ft)	0.013214	Area (sq ft)		21.05
Q Total (cfs)	150.00	Flow (cfs)		150.00
Top width (ft)	13.60	Top width (ft)		13.60
Vel Total (ft/s)	7.12	Avg. Vel. (ft/s)		7.12
Max Chl Dpth (ft)	2.73	Hydr. Depth (ft)		1.55
Conv. Total (cfs)	1304.9	Conv. (cfs)		1304.9
Length wtd. (ft)		wetted Per. (ft)		15.04
Min Ch El (ft)	646.20	Shear (lb/sq ft)		1.15
Alpha 28.00	1.00	Stream Power (lb/ft s)	92.00	-18.00
Frctn Loss (ft)		Cum Volume (acre-ft)		
C & E Loss (ft)		Cum SA (acres)		

Warning: Slope too steep for slope area to converge during supercritical flow calculations (normal depth is below critical depth).

Water surface set to critical depth.

Note: Multiple critical depths were found at this location. The critical depth with the lowest, valid, energy was used.

CROSS SECTION OUTPUT Profile #PF 13

E.G. Elev (ft)	649.97	Element	Left OB	Channel
Right OB Vel Head (ft)	0.84	wt. n-Val.		0.030
W.S. Elev (ft)	649.13	Reach Len. (ft)		
Crit W.S. (ft)	649.13	Flow Area (sq ft)		23.77
E.G. Slope (ft/ft)	0.012645	Area (sq ft)		23.77
Q Total (cfs)	175.00	Flow (cfs)		175.00
Top width (ft)	14.04	Top width (ft)		14.04
Vel Total (ft/s)	7.36	Avg. Vel. (ft/s)		7.36

WestTribClow.rep

Max Chl Dpth (ft)	2.93	Hydr. Depth (ft)		1.69
Conv. Total (cfs)	1556.2	Conv. (cfs)		1556.2
Length wtd. (ft)		wetted Per. (ft)		15.64
Min Ch El (ft)	646.20	Shear (lb/sq ft)		1.20
Alpha	1.00	Stream Power (lb/ft s)	92.00	-18.00
28.00				
Frctn Loss (ft)		Cum Volume (acre-ft)		
C & E Loss (ft)		Cum SA (acres)		

Warning: Slope too steep for slope area to converge during supercritical flow calculations (normal depth is below critical depth).

water surface set to critical depth.

Note: Multiple critical depths were found at this location. The critical depth with the lowest, valid, energy was used.

CROSS SECTION OUTPUT Profile #PF 14

E.G. Elev (ft)	650.20	Element	Left OB	Channel
Right OB				
Vel Head (ft)	0.91	wt. n-Val.		0.030
w.S. Elev (ft)	649.30	Reach Len. (ft)		
Crit w.S. (ft)	649.30	Flow Area (sq ft)		26.20
E.G. Slope (ft/ft)	0.012479	Area (sq ft)		26.20
Q Total (cfs)	200.00	Flow (cfs)		200.00
Top Width (ft)	14.42	Top Width (ft)		14.42
Vel Total (ft/s)	7.63	Avg. Vel. (ft/s)		7.63
Max Chl Dpth (ft)	3.10	Hydr. Depth (ft)		1.82
Conv. Total (cfs)	1790.4	Conv. (cfs)		1790.4
Length wtd. (ft)		wetted Per. (ft)		16.16
Min Ch El (ft)	646.20	Shear (lb/sq ft)		1.26
Alpha	1.00	Stream Power (lb/ft s)	92.00	-18.00
28.00				
Frctn Loss (ft)		Cum Volume (acre-ft)		
C & E Loss (ft)		Cum SA (acres)		

Warning: Slope too steep for slope area to converge during supercritical flow calculations (normal depth is below critical depth).

water surface set to critical depth.

Note: Multiple critical depths were found at this location. The critical depth with the lowest, valid, energy was used.

CROSS SECTION OUTPUT Profile #PF 15

E.G. Elev (ft)	650.43	Element	Left OB	Channel
Right OB Vel Head (ft)	0.96	wt. n-Val.		0.030
W.S. Elev (ft)	649.46	Reach Len. (ft)		
Crit W.S. (ft)	649.46	Flow Area (sq ft)		28.60
E.G. Slope (ft/ft)	0.012273	Area (sq ft)		28.60
Q Total (cfs)	225.00	Flow (cfs)		225.00
Top width (ft)	14.79	Top width (ft)		14.79
Vel Total (ft/s)	7.87	Avg. Vel. (ft/s)		7.87
Max Chl Dpth (ft)	3.26	Hydr. Depth (ft)		1.93
Conv. Total (cfs)	2031.0	Conv. (cfs)		2031.0
Length wtd. (ft)		wetted Per. (ft)		16.66
Min Ch El (ft)	646.20	Shear (lb/sq ft)		1.32
Alpha	1.00	Stream Power (lb/ft s)	92.00	-18.00
28.00 Frctn Loss (ft)		Cum Volume (acre-ft)		
C & E Loss (ft)		Cum SA (acres)		

Warning: Slope too steep for slope area to converge during supercritical flow calculations (normal depth is below critical depth).

Water surface set to critical depth.

Note: Multiple critical depths were found at this location. The critical depth with the lowest, valid, energy was used.

CROSS SECTION OUTPUT Profile #PF 16

E.G. Elev (ft)	650.63	Element	Left OB	Channel
Right OB Vel Head (ft)	1.02	wt. n-Val.		0.030
W.S. Elev (ft)	649.62	Reach Len. (ft)		
Crit W.S. (ft)	649.62	Flow Area (sq ft)		30.89
E.G. Slope (ft/ft)	0.012168	Area (sq ft)		30.89
Q Total (cfs)	250.00	Flow (cfs)		250.00
Top width (ft)	15.14	Top width (ft)		15.14
Vel Total (ft/s)	8.09	Avg. Vel. (ft/s)		8.09

WestTribClow.rep

Max Chl Dpth (ft)	3.42	Hydr. Depth (ft)		2.04
Conv. Total (cfs)	2266.4	Conv. (cfs)		2266.4
Length wtd. (ft)		wetted Per. (ft)		17.13
Min Ch El (ft)	646.20	Shear (lb/sq ft)		1.37
Alpha	1.00	Stream Power (lb/ft s)	92.00	-18.00
28.00				
Frctn Loss (ft)		Cum Volume (acre-ft)		
C & E Loss (ft)		Cum SA (acres)		

Warning: Slope too steep for slope area to converge during supercritical flow calculations (normal depth is below critical depth).

Water surface set to critical depth.

Note: Multiple critical depths were found at this location. The critical depth with the lowest, valid, energy was used.

CROSS SECTION OUTPUT Profile #PF 17

E.G. Elev (ft)	650.83	Element	Left OB	Channel
Right OB				
Vel Head (ft)	1.07	wt. n-Val.		0.030
w.S. Elev (ft)	649.76	Reach Len. (ft)		
Crit w.S. (ft)	649.76	Flow Area (sq ft)		33.09
E.G. Slope (ft/ft)	0.012104	Area (sq ft)		33.09
Q Total (cfs)	275.00	Flow (cfs)		275.00
Top Width (ft)	15.46	Top Width (ft)		15.46
Vel Total (ft/s)	8.31	Avg. Vel. (ft/s)		8.31
Max Chl Dpth (ft)	3.56	Hydr. Depth (ft)		2.14
Conv. Total (cfs)	2499.6	Conv. (cfs)		2499.6
Length wtd. (ft)		wetted Per. (ft)		17.57
Min Ch El (ft)	646.20	Shear (lb/sq ft)		1.42
Alpha	1.00	Stream Power (lb/ft s)	92.00	-18.00
28.00				
Frctn Loss (ft)		Cum Volume (acre-ft)		
C & E Loss (ft)		Cum SA (acres)		

Warning: Slope too steep for slope area to converge during supercritical flow calculations (normal depth is below critical depth).

Water surface set to critical depth.

Note: Multiple critical depths were found at this location. The critical depth with the lowest, valid, energy was used.

CROSS SECTION OUTPUT Profile #PF 18

E.G. Elev (ft)	651.02	Element	Left OB	Channel
Right OB Vel Head (ft)	1.12	wt. n-Val.		0.030
W.S. Elev (ft)	649.91	Reach Len. (ft)		
Crit W.S. (ft)	649.91	Flow Area (sq ft)		35.36
E.G. Slope (ft/ft)	0.011936	Area (sq ft)		35.36
Q Total (cfs)	300.00	Flow (cfs)		300.00
Top width (ft)	15.79	Top width (ft)		15.79
Vel Total (ft/s)	8.48	Avg. Vel. (ft/s)		8.48
Max Chl Dpth (ft)	3.71	Hydr. Depth (ft)		2.24
Conv. Total (cfs)	2746.0	Conv. (cfs)		2746.0
Length wtd. (ft)		wetted Per. (ft)		18.01
Min Ch El (ft)	646.20	Shear (lb/sq ft)		1.46
Alpha	1.00	Stream Power (lb/ft s)	92.00	-18.00
28.00 Frctn Loss (ft)		Cum Volume (acre-ft)		
C & E Loss (ft)		Cum SA (acres)		

Warning: Slope too steep for slope area to converge during supercritical flow calculations (normal depth is below critical depth).

Water surface set to critical depth.

Note: Multiple critical depths were found at this location. The critical depth with the lowest, valid, energy was used.

CROSS SECTION OUTPUT Profile #PF 19

E.G. Elev (ft)	651.21	Element	Left OB	Channel
Right OB Vel Head (ft)	1.16	wt. n-Val.		0.030
W.S. Elev (ft)	650.04	Reach Len. (ft)		
Crit W.S. (ft)	650.04	Flow Area (sq ft)		37.56
E.G. Slope (ft/ft)	0.011812	Area (sq ft)		37.56
Q Total (cfs)	325.00	Flow (cfs)		325.00
Top width (ft)	16.09	Top width (ft)		16.09
Vel Total (ft/s)	8.65	Avg. Vel. (ft/s)		8.65

WestTribClow.rep

Max Chl Dpth (ft)	3.84	Hydr. Depth (ft)		2.33
Conv. Total (cfs)	2990.4	Conv. (cfs)		2990.4
Length wtd. (ft)		wetted Per. (ft)		18.43
Min Ch El (ft)	646.20	Shear (lb/sq ft)		1.50
Alpha 28.00	1.00	Stream Power (lb/ft s)	92.00	-18.00
Frctn Loss (ft)		Cum Volume (acre-ft)		
C & E Loss (ft)		Cum SA (acres)		

Warning: Slope too steep for slope area to converge during supercritical flow calculations (normal depth is below critical depth).

water surface set to critical depth.

Note: Multiple critical depths were found at this location. The critical depth with the lowest, valid, energy was used.

CROSS SECTION OUTPUT Profile #PF 20

E.G. Elev (ft)	651.38	Element	Left OB	Channel
Right OB Vel Head (ft)	1.21	wt. n-Val.		0.030
w.S. Elev (ft)	650.18	Reach Len. (ft)		
Crit w.S. (ft)	650.18	Flow Area (sq ft)		39.69
E.G. Slope (ft/ft)	0.011718	Area (sq ft)		39.69
Q Total (cfs)	350.00	Flow (cfs)		350.00
Top Width (ft)	16.35	Top Width (ft)		16.35
Vel Total (ft/s)	8.82	Avg. Vel. (ft/s)		8.82
Max Chl Dpth (ft)	3.98	Hydr. Depth (ft)		2.43
Conv. Total (cfs)	3233.3	Conv. (cfs)		3233.3
Length wtd. (ft)		wetted Per. (ft)		18.81
Min Ch El (ft)	646.20	Shear (lb/sq ft)		1.54
Alpha 28.00	1.00	Stream Power (lb/ft s)	92.00	-18.00
Frctn Loss (ft)		Cum Volume (acre-ft)		
C & E Loss (ft)		Cum SA (acres)		

Warning: Slope too steep for slope area to converge during supercritical flow calculations (normal depth is below critical depth).

water surface set to critical depth.

Note: Multiple critical depths were found at this location. The critical depth with the lowest, valid, energy was used.

CROSS SECTION OUTPUT Profile #PF 21

E.G. Elev (ft)	651.55	Element	Left OB	Channel
Right OB Vel Head (ft)	1.25	wt. n-Val.		0.030
W.S. Elev (ft)	650.30	Reach Len. (ft)		
Crit W.S. (ft)	650.30	Flow Area (sq ft)		41.75
E.G. Slope (ft/ft)	0.011656	Area (sq ft)		41.75
Q Total (cfs)	375.00	Flow (cfs)		375.00
Top width (ft)	16.60	Top width (ft)		16.60
Vel Total (ft/s)	8.98	Avg. Vel. (ft/s)		8.98
Max Chl Dpth (ft)	4.10	Hydr. Depth (ft)		2.51
Conv. Total (cfs)	3473.5	Conv. (cfs)		3473.5
Length wtd. (ft)		wetted Per. (ft)		19.18
Min Ch El (ft)	646.20	Shear (lb/sq ft)		1.58
Alpha	1.00	Stream Power (lb/ft s)	92.00	-18.00
28.00 Frctn Loss (ft)		Cum Volume (acre-ft)		
C & E Loss (ft)		Cum SA (acres)		

Warning: Slope too steep for slope area to converge during supercritical flow calculations (normal depth is below critical depth).

Water surface set to critical depth.

Note: Multiple critical depths were found at this location. The critical depth with the lowest, valid, energy was used.

CROSS SECTION OUTPUT Profile #PF 22

E.G. Elev (ft)	651.72	Element	Left OB	Channel
Right OB Vel Head (ft)	1.30	wt. n-Val.		0.030
W.S. Elev (ft)	650.42	Reach Len. (ft)		
Crit W.S. (ft)	650.42	Flow Area (sq ft)		43.69
E.G. Slope (ft/ft)	0.011666	Area (sq ft)		43.69
Q Total (cfs)	400.00	Flow (cfs)		400.00
Top width (ft)	16.83	Top width (ft)		16.83
Vel Total (ft/s)	9.16	Avg. Vel. (ft/s)		9.16

WestTribClow.rep

Max Chl Dpth (ft)	4.22	Hydr. Depth (ft)		2.60
Conv. Total (cfs)	3703.4	Conv. (cfs)		3703.4
Length wtd. (ft)		wetted Per. (ft)		19.52
Min Ch El (ft)	646.20	Shear (lb/sq ft)		1.63
Alpha 28.00	1.00	Stream Power (lb/ft s)	92.00	-18.00
Frctn Loss (ft)		Cum Volume (acre-ft)		
C & E Loss (ft)		Cum SA (acres)		

Warning: Slope too steep for slope area to converge during supercritical flow calculations (normal depth is below critical depth).

water surface set to critical depth.

Note: Multiple critical depths were found at this location. The critical depth with the lowest, valid, energy was used.

CROSS SECTION OUTPUT Profile #PF 23

E.G. Elev (ft)	651.88	Element	Left OB	Channel
Right OB Vel Head (ft)	1.34	wt. n-Val.		0.030
w.S. Elev (ft)	650.54	Reach Len. (ft)		
Crit w.S. (ft)	650.54	Flow Area (sq ft)		45.82
E.G. Slope (ft/ft)	0.011523	Area (sq ft)		45.82
Q Total (cfs)	425.00	Flow (cfs)		425.00
Top width (ft)	17.08	Top width (ft)		17.08
Vel Total (ft/s)	9.28	Avg. Vel. (ft/s)		9.28
Max Chl Dpth (ft)	4.34	Hydr. Depth (ft)		2.68
Conv. Total (cfs)	3959.3	Conv. (cfs)		3959.3
Length wtd. (ft)		wetted Per. (ft)		19.88
Min Ch El (ft)	646.20	Shear (lb/sq ft)		1.66
Alpha 28.00	1.00	Stream Power (lb/ft s)	92.00	-18.00
Frctn Loss (ft)		Cum Volume (acre-ft)		
C & E Loss (ft)		Cum SA (acres)		

Warning: Slope too steep for slope area to converge during supercritical flow calculations (normal depth is below critical depth).

water surface set to critical depth.

Note: Multiple critical depths were found at this location. The critical depth with the lowest, valid, energy was used.

CROSS SECTION OUTPUT Profile #PF 24

E.G. Elev (ft)	652.03	Element	Left OB	Channel
Right OB Vel Head (ft)	1.37	wt. n-Val.		0.030
W.S. Elev (ft)	650.66	Reach Len. (ft)		
Crit w.s. (ft)	650.66	Flow Area (sq ft)		47.84
E.G. Slope (ft/ft)	0.011446	Area (sq ft)		47.84
Q Total (cfs)	450.00	Flow (cfs)		450.00
Top width (ft)	17.32	Top width (ft)		17.32
Vel Total (ft/s)	9.41	Avg. Vel. (ft/s)		9.41
Max Chl Dpth (ft)	4.46	Hydr. Depth (ft)		2.76
Conv. Total (cfs)	4206.1	Conv. (cfs)		4206.1
Length wtd. (ft)		wetted Per. (ft)		20.23
Min Ch El (ft)	646.20	Shear (lb/sq ft)		1.69
Alpha 28.00	1.00	Stream Power (lb/ft s)	92.00	-18.00
Frctn Loss (ft)		Cum Volume (acre-ft)		
C & E Loss (ft)		Cum SA (acres)		

Warning: Slope too steep for slope area to converge during supercritical flow calculations (normal depth is below critical depth).

Water surface set to critical depth.

Note: Multiple critical depths were found at this location. The critical depth with the lowest, valid, energy was used.

CROSS SECTION OUTPUT Profile #PF 25

E.G. Elev (ft)	652.18	Element	Left OB	Channel
Right OB Vel Head (ft)	1.41	wt. n-Val.		0.030
W.S. Elev (ft)	650.77	Reach Len. (ft)		
Crit w.s. (ft)	650.77	Flow Area (sq ft)		49.80
E.G. Slope (ft/ft)	0.011395	Area (sq ft)		49.80
Q Total (cfs)	475.00	Flow (cfs)		475.00
Top width (ft)	17.54	Top width (ft)		17.54
Vel Total (ft/s)	9.54	Avg. Vel. (ft/s)		9.54

WestTribClow.rep

Max Chl Dpth (ft)	4.57	Hydr. Depth (ft)		2.84
Conv. Total (cfs)	4449.8	Conv. (cfs)		4449.8
Length wtd. (ft)		wetted Per. (ft)		20.55
Min Ch El (ft)	646.20	Shear (lb/sq ft)		1.72
Alpha	1.00	Stream Power (lb/ft s)	92.00	-18.00
28.00				
Frctn Loss (ft)		Cum Volume (acre-ft)		
C & E Loss (ft)		Cum SA (acres)		

Warning: Slope too steep for slope area to converge during supercritical flow calculations (normal depth is below critical depth).

water surface set to critical depth.

Note: Multiple critical depths were found at this location. The critical depth with the lowest, valid, energy was used.

CROSS SECTION OUTPUT Profile #PF 26

E.G. Elev (ft)	652.33	Element	Left OB	Channel
Right OB				
Vel Head (ft)	1.45	wt. n-Val.		0.030
w.S. Elev (ft)	650.88	Reach Len. (ft)		
Crit w.S. (ft)	650.88	Flow Area (sq ft)		51.68
E.G. Slope (ft/ft)	0.011385	Area (sq ft)		51.68
Q Total (cfs)	500.00	Flow (cfs)		500.00
Top Width (ft)	17.76	Top Width (ft)		17.76
Vel Total (ft/s)	9.67	Avg. Vel. (ft/s)		9.67
Max Chl Dpth (ft)	4.68	Hydr. Depth (ft)		2.91
Conv. Total (cfs)	4686.0	Conv. (cfs)		4686.0
Length wtd. (ft)		wetted Per. (ft)		20.87
Min Ch El (ft)	646.20	Shear (lb/sq ft)		1.76
Alpha	1.00	Stream Power (lb/ft s)	92.00	-18.00
28.00				
Frctn Loss (ft)		Cum Volume (acre-ft)		
C & E Loss (ft)		Cum SA (acres)		

Warning: Slope too steep for slope area to converge during supercritical flow calculations (normal depth is below critical depth).

water surface set to critical depth.

Note: Multiple critical depths were found at this location. The critical depth with the lowest, valid, energy was used.

CROSS SECTION OUTPUT Profile #PF 27

E.G. Elev (ft)	652.48	Element	Left OB	Channel
Right OB Vel Head (ft)	1.49	wt. n-Val.		0.030
W.S. Elev (ft)	650.98	Reach Len. (ft)		
Crit W.S. (ft)	650.98	Flow Area (sq ft)		53.51
E.G. Slope (ft/ft)	0.011393	Area (sq ft)		53.51
Q Total (cfs)	525.00	Flow (cfs)		525.00
Top width (ft)	17.96	Top width (ft)		17.96
Vel Total (ft/s)	9.81	Avg. Vel. (ft/s)		9.81
Max Chl Dpth (ft)	4.78	Hydr. Depth (ft)		2.98
Conv. Total (cfs)	4918.6	Conv. (cfs)		4918.6
Length wtd. (ft)		wetted Per. (ft)		21.16
Min Ch El (ft)	646.20	Shear (lb/sq ft)		1.80
Alpha	1.00	Stream Power (lb/ft s)	92.00	-18.00
28.00 Frctn Loss (ft)		Cum Volume (acre-ft)		
C & E Loss (ft)		Cum SA (acres)		

Warning: Slope too steep for slope area to converge during supercritical flow calculations (normal depth is below critical depth).

Water surface set to critical depth.

Note: Multiple critical depths were found at this location. The critical depth with the lowest, valid, energy was used.

CROSS SECTION OUTPUT Profile #PF 28

E.G. Elev (ft)	652.61	Element	Left OB	Channel
Right OB Vel Head (ft)	1.42	wt. n-Val.		0.030
W.S. Elev (ft)	651.19	Reach Len. (ft)		
Crit W.S. (ft)	651.19	Flow Area (sq ft)		57.50
E.G. Slope (ft/ft)	0.011258	Area (sq ft)		57.50
Q Total (cfs)	550.00	Flow (cfs)		550.00
Top width (ft)	20.11	Top width (ft)		20.11
Vel Total (ft/s)	9.57	Avg. Vel. (ft/s)		9.57

WestTribClow.rep

Max Chl Dpth (ft)	4.99	Hydr. Depth (ft)		2.86
Conv. Total (cfs)	5183.6	Conv. (cfs)		5183.6
Length wtd. (ft)		wetted Per. (ft)		23.42
Min Ch El (ft)	646.20	Shear (lb/sq ft)		1.73
Alpha	1.00	Stream Power (lb/ft s)	92.00	-18.00
28.00				
Frctn Loss (ft)		Cum Volume (acre-ft)		
C & E Loss (ft)		Cum SA (acres)		

Warning: Slope too steep for slope area to converge during supercritical flow calculations (normal depth is below critical depth).

Water surface set to critical depth.

Note: Multiple critical depths were found at this location. The critical depth with the lowest, valid, energy was used.

CROSS SECTION OUTPUT Profile #PF 29

E.G. Elev (ft)	652.74	Element	Left OB	Channel
Right OB				
Vel Head (ft)	1.38	wt. n-Val.		0.030
w.S. Elev (ft)	651.36	Reach Len. (ft)		
Crit w.S. (ft)	651.36	Flow Area (sq ft)		60.96
E.G. Slope (ft/ft)	0.011228	Area (sq ft)		60.96
Q Total (cfs)	575.00	Flow (cfs)		575.00
Top width (ft)	21.92	Top width (ft)		21.92
Vel Total (ft/s)	9.43	Avg. Vel. (ft/s)		9.43
Max Chl Dpth (ft)	5.16	Hydr. Depth (ft)		2.78
Conv. Total (cfs)	5426.4	Conv. (cfs)		5426.4
Length wtd. (ft)		wetted Per. (ft)		25.31
Min Ch El (ft)	646.20	Shear (lb/sq ft)		1.69
Alpha	1.00	Stream Power (lb/ft s)	92.00	-18.00
28.00				
Frctn Loss (ft)		Cum Volume (acre-ft)		
C & E Loss (ft)		Cum SA (acres)		

Warning: Slope too steep for slope area to converge during supercritical flow calculations (normal depth is below critical depth).

Water surface set to critical depth.

Note: Multiple critical depths were found at this location. The critical depth with the lowest, valid, energy was used.

CROSS SECTION OUTPUT Profile #PF 30

E.G. Elev (ft)	652.86	Element	Left OB	Channel
Right OB Vel Head (ft)	1.37	wt. n-Val.		0.030
W.S. Elev (ft)	651.48	Reach Len. (ft)		
Crit W.S. (ft)	651.48	Flow Area (sq ft)		63.78
E.G. Slope (ft/ft)	0.011316	Area (sq ft)		63.78
Q Total (cfs)	600.00	Flow (cfs)		600.00
Top width (ft)	23.29	Top width (ft)		23.29
Vel Total (ft/s)	9.41	Avg. Vel. (ft/s)		9.41
Max Chl Dpth (ft)	5.28	Hydr. Depth (ft)		2.74
Conv. Total (cfs)	5640.3	Conv. (cfs)		5640.3
Length wtd. (ft)		wetted Per. (ft)		26.73
Min Ch El (ft)	646.20	Shear (lb/sq ft)		1.69
Alpha 28.00	1.00	Stream Power (lb/ft s)	92.00	-18.00
Frctn Loss (ft)		Cum Volume (acre-ft)		
C & E Loss (ft)		Cum SA (acres)		

Warning: Slope too steep for slope area to converge during supercritical flow calculations (normal depth is below critical depth).
Water surface set to critical depth.

Note: Multiple critical depths were found at this location. The critical depth with the lowest, valid, energy was used.

SUMMARY OF MANNING'S N VALUES

River:WestTribClow

Reach	River Sta.	n1	n2	n3
WestTribClow	1811	.08	.03	.08
WestTribClow	1800	Culvert		
WestTribClow	1787	.08	.03	.08
WestTribClow	1777	.08	.03	.08
WestTribClow	1709	.08	.03	.08
WestTribClow	1627	.08	.03	.08
WestTribClow	1500	.08	.03	.08
WestTribClow	1350	.08	.03	.08
WestTribClow	1200	.08	.03	.08
WestTribClow	1100	.08	.03	.08

westTribClow	1811	westTribClow.rep		
	1000	.08	.03	.08

SUMMARY OF REACH LENGTHS

River: westTribClow

Reach	River Sta.	Left	Channel	Right
westTribClow	1811	34	34	34
westTribClow	1800	Culvert		
westTribClow	1787	10	10	10
westTribClow	1777	114	68	87
westTribClow	1709	76	82	60
westTribClow	1627	147	127	147
westTribClow	1500	148	150	142
westTribClow	1350	134	150	128
westTribClow	1200	112	100	97
westTribClow	1100	112	100	97
westTribClow	1000	0	0	0

SUMMARY OF CONTRACTION AND EXPANSION COEFFICIENTS

River: westTribClow

Reach	River Sta.	Contr.	Expan.
westTribClow	1811	.1	.3
westTribClow	1800	Culvert	
westTribClow	1787	.1	.3
westTribClow	1777	.1	.3
westTribClow	1709	.1	.3
westTribClow	1627	.1	.3
westTribClow	1500	.1	.3
westTribClow	1350	.1	.3
westTribClow	1200	.1	.3
westTribClow	1100	.1	.3
westTribClow	1000	.1	.3

EXHIBIT I

EXISTING CONDITIONS FLOODPLAIN CROSS SECTIONS

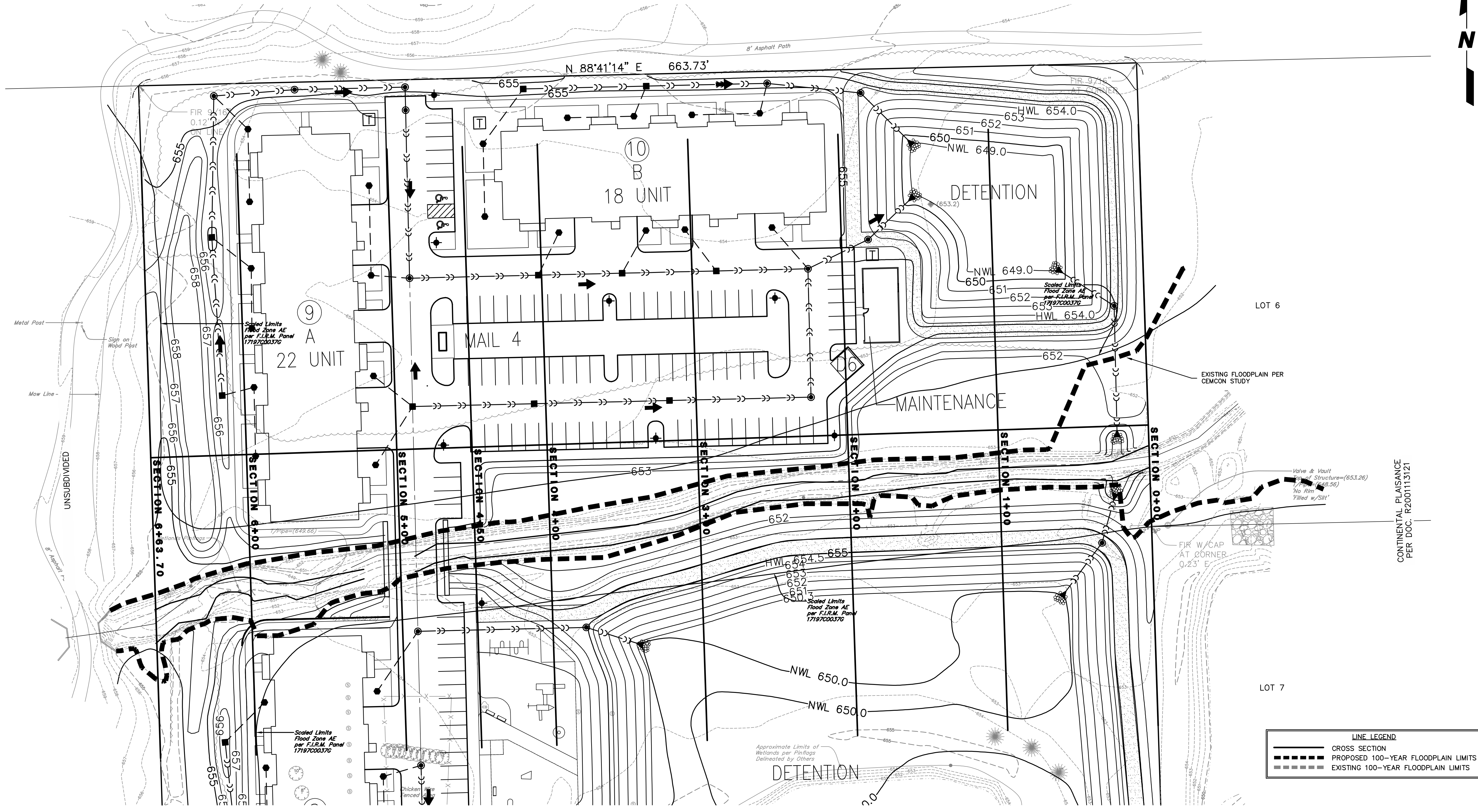
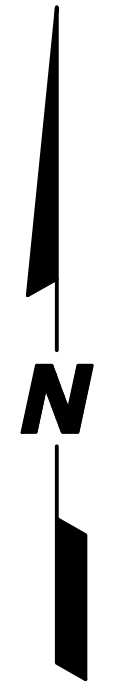

LINE LEGEND	
	CROSS SECTION
	PROPOSED 100-YEAR FLOODPLAIN LIMITS
	EXISTING 100-YEAR FLOODPLAIN LIMITS

FLOODPLAIN SECTIONS FOR THE BELVEDERE
CITY OF NAPERVILLE PROJECT NO. : XX-XXXXXXX

Copyright © 2022 Cemcon, Ltd. All rights reserved.

PLOT FILE CREATED: 3/29/2022 4:25 PM BY KRISTIN STAERKEL DRAWING LAST SAVED: 3/29/2022 4:25 PM BY KRIS DRAWING PATH: F:\904411\DWG\ENG\DRAWINGS\EXHIBITS\FLD_XSEC.DWG

PREPARED FOR:
BRIDGE CAPITAL PARTNERS
899 PNE STREET #2000
SAN FRANCISCO, CA. 94108

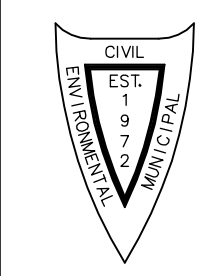

PREPARED BY:
CEMCON, Ltd.
Consulting Engineers, Land Surveyors & Planners
2280 White Oak Circle, Suite 100
Aurora, Illinois 60502-9675
Ph: 630.862.2100 Fax: 630.862.2199
E-Mail: cadd@cemcon.com Website: www.cemcon.com

REVISIONS		
NO.	DATE	DESCRIPTION

FLOODPLAIN SECTIONS
THE BELVEDERE

FILE NAME: FLD_XSEC	DSGN. BY: KMM	JOB NO.: 904.411	FLD. BK./PG.: -----	SHEET NO.
DIR: 904411	DRN. BY: KMS	DATE: 03-29-22	SCALE: 1" = 30'	01 of 03

PLOT FILE CREATED: 3/29/2022 4:25 PM BY KRISTIN STAERKEL DRAWING LAST SAVED: 3/29/2022 4:25 PM BY KRIS DRAWING PATH: F:\904411\DWG\ENG\DRAWINGS\EXHIBITS\FLD_XSEC.DWG

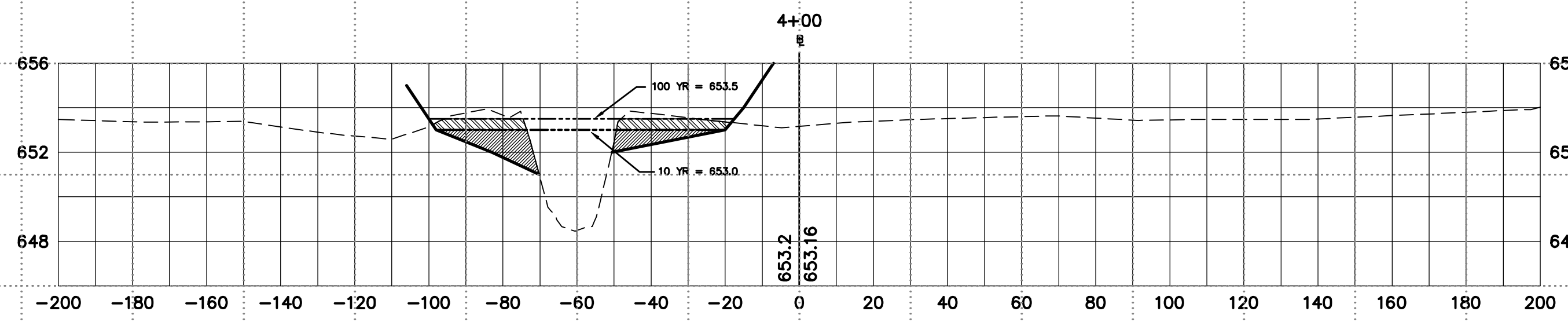

0-10 YEAR CUT	=	38.0
0-10 YEAR FILL	=	0.0
10-100 YEAR CUT	=	26.3
10-100 YEAR FILL	=	0.0
(ALL QUANTITIES IN SQUARE FEET)		

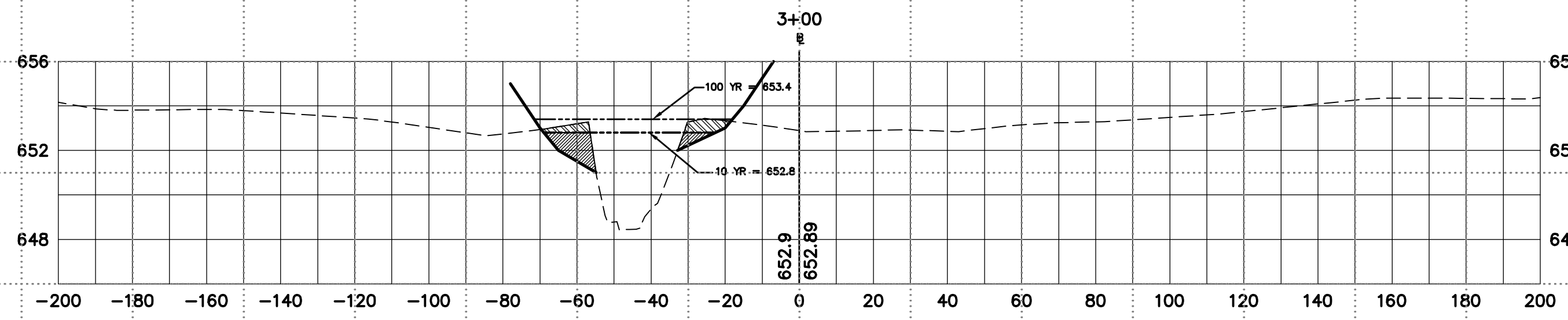

0-10 YEAR CUT	=	16.7
0-10 YEAR FILL	=	0.0
10-100 YEAR CUT	=	10.0
10-100 YEAR FILL	=	0.0
(ALL QUANTITIES IN SQUARE FEET)		

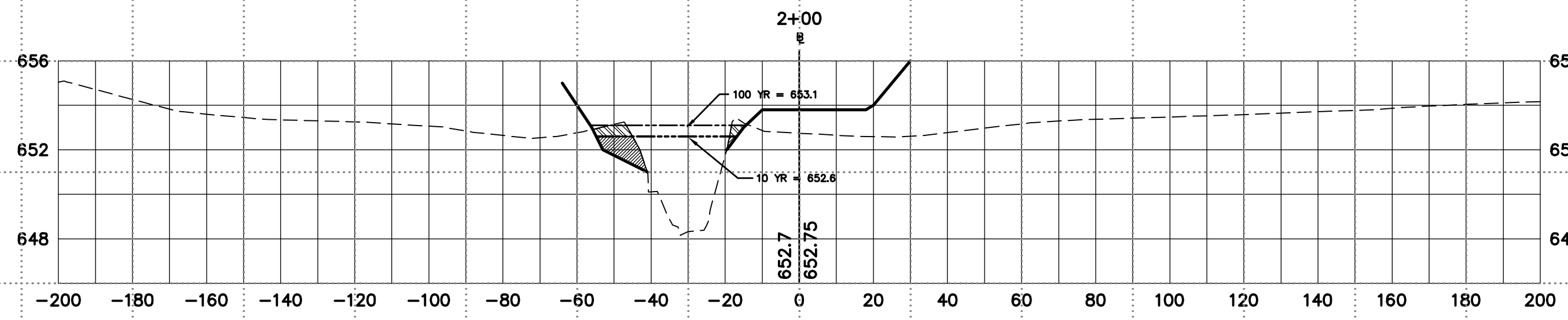

0-10 YEAR CUT	=	11.5
0-10 YEAR FILL	=	0.0
10-100 YEAR CUT	=	5.8
10-100 YEAR FILL	=	0.0
(ALL QUANTITIES IN SQUARE FEET)		

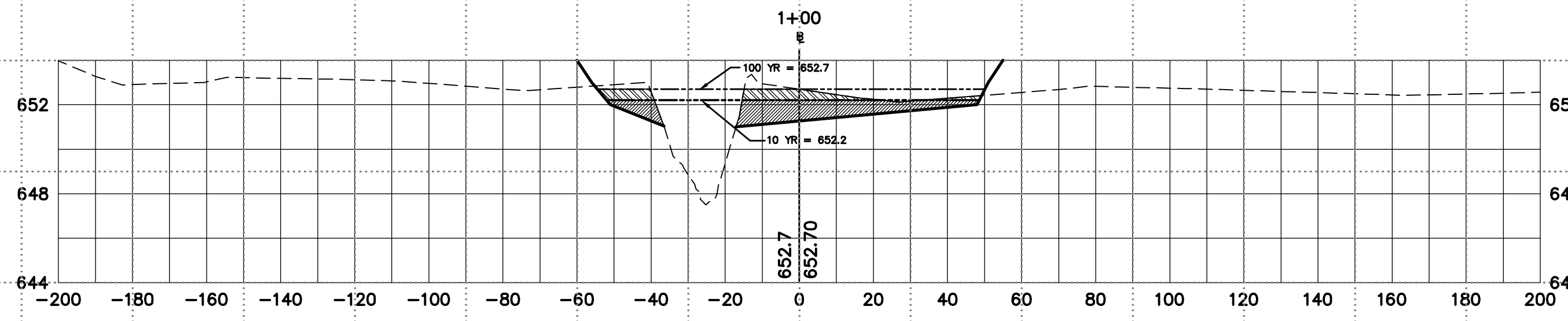

0-10 YEAR CUT	=	52.7
0-10 YEAR FILL	=	0.0
10-100 YEAR CUT	=	21.3
10-100 YEAR FILL	=	0.0
(ALL QUANTITIES IN SQUARE FEET)		

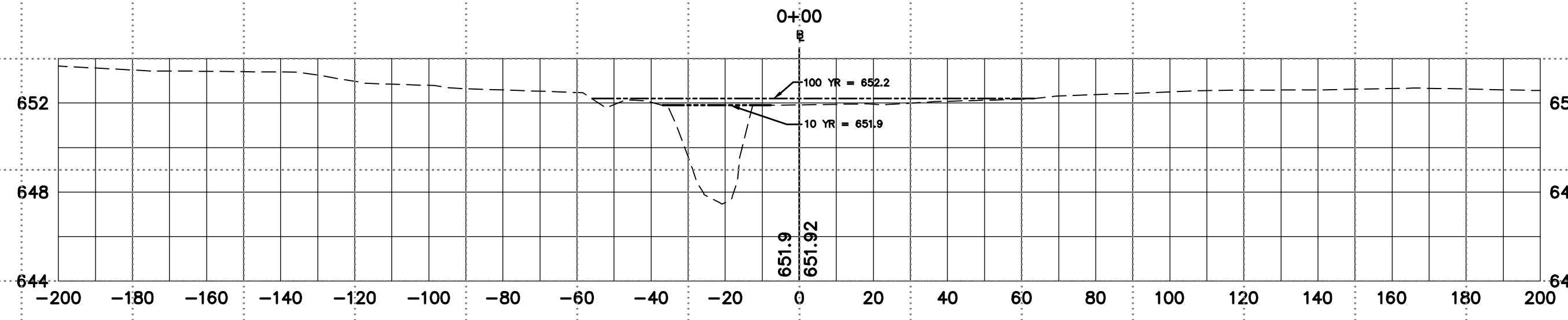

0-10 YEAR CUT	=	0.0
0-10 YEAR FILL	=	0.0
10-100 YEAR CUT	=	0.0
10-100 YEAR FILL	=	0.0
(ALL QUANTITIES IN SQUARE FEET)		

LINE LEGEND	
	EXISTING GROUND
	PROPOSED GROUND
	AS-BUILT GROUND
	10-YEAR FLOODPLAIN EL.
	100-YEAR FLOODPLAIN EL.
	ONSITE SWMF

FLOODPLAIN SECTIONS FOR THE BELVEDERE
CITY OF NAPERVILLE PROJECT NO. : XX-XXXXXXX

Copyright © 2022 Cemcon, Ltd. All rights reserved.

PREPARED FOR:
BRIDGE CAPITAL PARTNERS
899 PNE STREET #2000
SAN FRANCISCO, CA. 94108

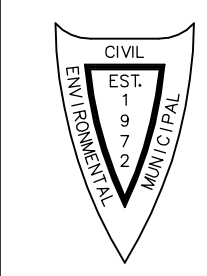

PREPARED BY:
CEMCON, Ltd.
Consulting Engineers, Land Surveyors & Planners
2280 White Oak Circle, Suite 100
Aurora, Illinois 60502-9575
Ph: 630.862.2100 Fax: 630.862.2199
E-Mail: cadd@cemcon.com Website: www.cemcon.com

REVISIONS		
NO.	DATE	DESCRIPTION

FLOODPLAIN SECTIONS
THE BELVEDERE

FILE NAME: FLD_XSEC	DSGN. BY: KMM	JOB NO.: 904.411	FLD. BK./PG.:D94	SHEET NO.
DIR: 904411	DRN. BY: KMS	DATE: 03-29-22	SCALE: 1" = 30'H,5'V	02 of 03

PLOT FILE CREATED: 3/29/2022 4:25 PM BY KRISTIN STAERKEL DRAWING LAST SAVED: 3/29/2022 4:25 PM BY KRIS DRAWING PATH: F:\904411\DWG\ENG\DRAWINGS\EXHIBITS\FLD_XSEC.DWG

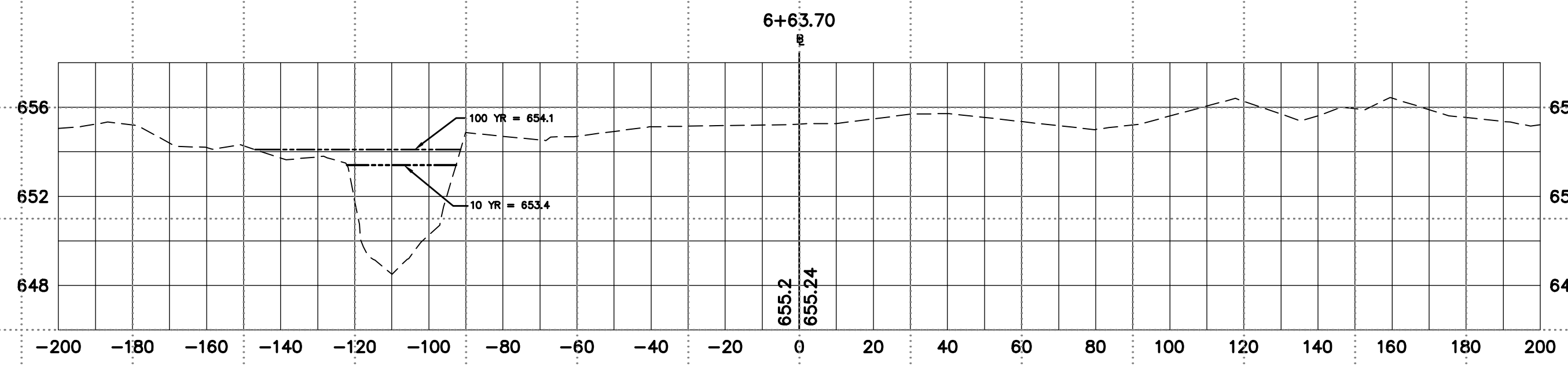

0-10 YEAR CUT	=	0.0
0-10 YEAR FILL	=	0.0
10-100 YEAR CUT	=	0.0
10-100 YEAR FILL	=	0.0
(ALL QUANTITIES IN SQUARE FEET)		

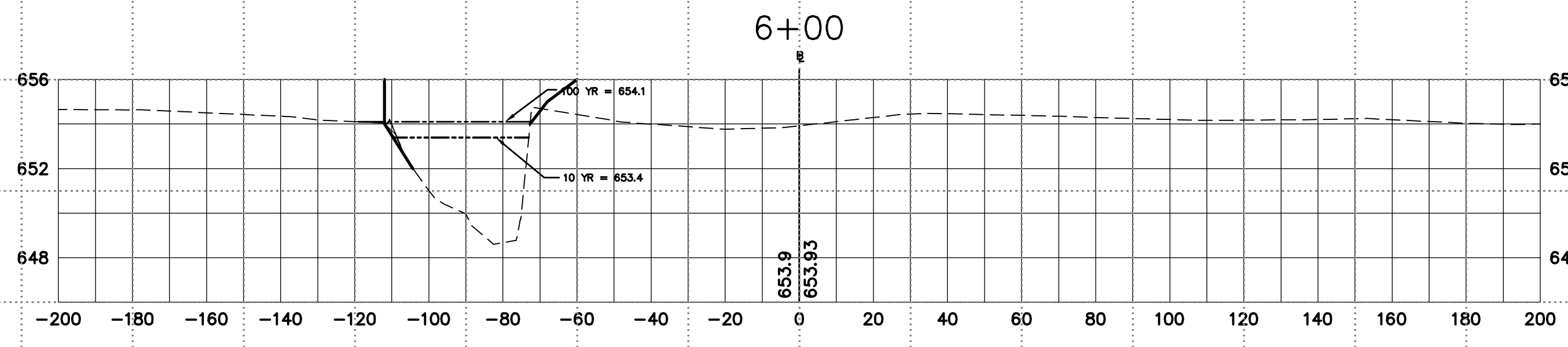

0-10 YEAR CUT	=	0.3
0-10 YEAR FILL	=	0.0
10-100 YEAR CUT	=	1.0
10-100 YEAR FILL	=	0.2
(ALL QUANTITIES IN SQUARE FEET)		

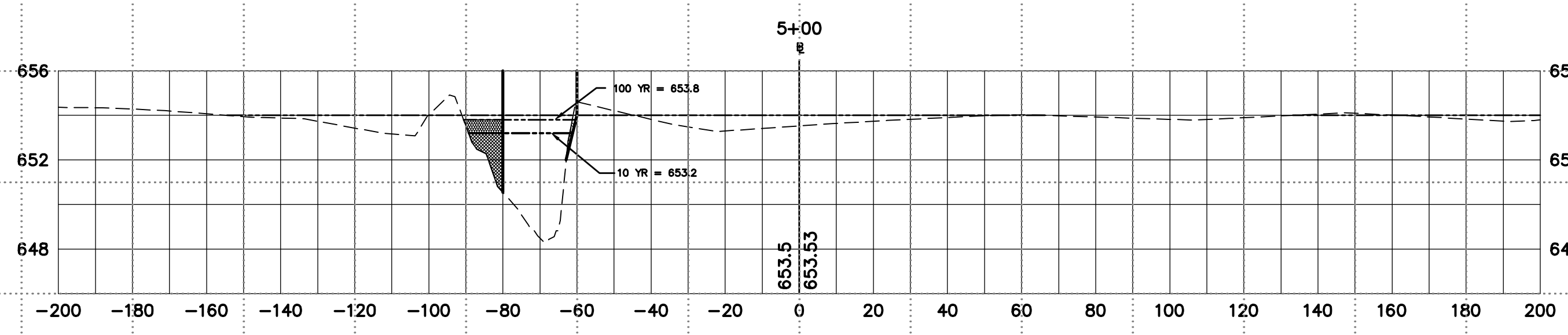

0-10 YEAR CUT	=	0.5
0-10 YEAR FILL	=	11.7
10-100 YEAR CUT	=	0.5
10-100 YEAR FILL	=	6.0
(ALL QUANTITIES IN SQUARE FEET)		

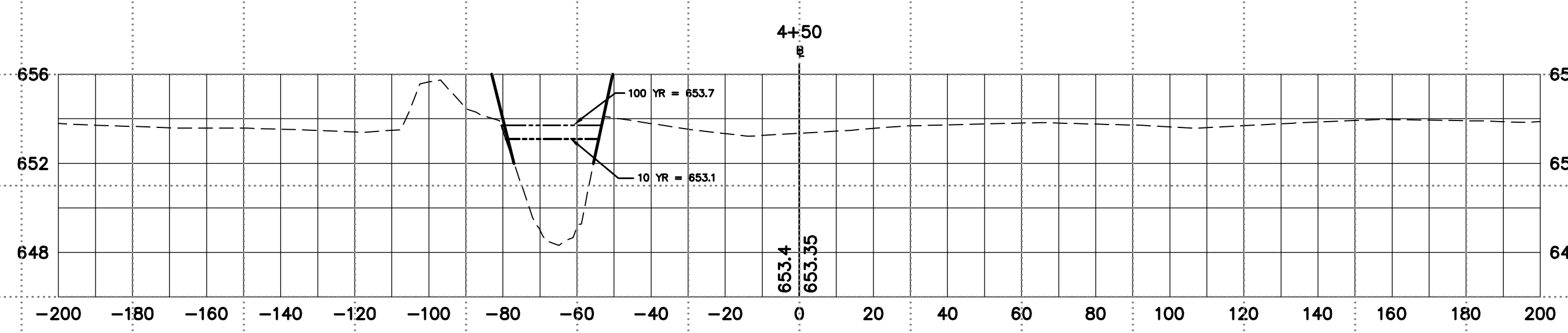

0-10 YEAR CUT	=	0.0
0-10 YEAR FILL	=	0.3
10-100 YEAR CUT	=	0.0
10-100 YEAR FILL	=	0.5
(ALL QUANTITIES IN SQUARE FEET)		

LINE LEGEND	
---	EXISTING GROUND
—	PROPOSED GROUND
- - -	AS-BUILT GROUND
---	10-YEAR FLOODPLAIN EL.
---	100-YEAR FLOODPLAIN EL.
---	ONSITE SWMF

FLOODPLAIN SECTIONS FOR THE BELVEDERE
CITY OF NAPERVILLE PROJECT NO. : XX-XXXXXXX

Copyright © 2022 Cemcon, Ltd. All rights reserved.

PREPARED FOR:
BRIDGE CAPITAL PARTNERS
899 PNE STREET #2000
SAN FRANCISCO, CA. 94108

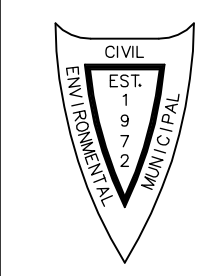

PREPARED BY:
CEMCON, Ltd.
Consulting Engineers, Land Surveyors & Planners
2280 White Oak Circle, Suite 100
Aurora, Illinois 60502-9675
Ph: 630.862.2100 Fax: 630.862.2199
E-Mail: cadd@cemcon.com Website: www.cemcon.com

REVISIONS		
NO.	DATE	DESCRIPTION

FLOODPLAIN SECTIONS
THE BELVEDERE

FILE NAME: FLD XSEC	DSGN. BY: KMM	JOB NO.: 904.411	FLD. BK./PG.:D94	SHEET NO.
DIR: 904411	DRN. BY: KMS	DATE: 03-29-22	SCALE: 1" = 30'H,5'V	03 of 03

EXHIBIT J

EXISTING CONDITIONS SUPPORTING CALCULATIONS

Worksheet 2: Runoff Curve Number and Runoff

Project _____
 Location Naperville, Illinois

By KPB Date 3/16/2022
 Checked _____ Date _____

Circle one: Present Developed

RUNOFF AREA : 001

1. Runoff curve number (CN)

Soil Name and Hydrologic Group	Cover Description (cover type, treatment, and hydrologic condition; percent impervious; unconnected/connected impervious area ratio)	CN ^{1/}			Area <u>X</u> acres mi ² %	Product of CN x Area
		Table 2-2	Fig. 2-3	Fig. 2-4		
B	Grass (Open Space, Good)	61			9.96	607.56
C	Grass (Open Space, Good)	74			5.31	392.94
	Buildings	98			2.05	200.9
B	Gravel	85			0.48	40.8
C	Gravel	89			0.25	22.25
	Asphalt	98			0.48	47.04
	Concrete	98			0.03	2.94
	Open Water (Creek at NWL)	98			0.02	1.96
Totals =					18.58	1316.390

1/ Use only one CN source per line.

$$\text{CN (weighted) = } \frac{\text{Total Product}}{\text{Total Area}} = \frac{1316.390}{18.580} = \underline{70.850}$$

Use CN = 70.8

2. Runoff

Frequency	yr	<table border="1" style="width: 100%;"><tr><td>Storm #1</td><td>Storm #2</td><td>Storm #3</td></tr><tr><td> </td><td> </td><td> </td></tr><tr><td> </td><td> </td><td> </td></tr><tr><td> </td><td> </td><td> </td></tr></table>	Storm #1	Storm #2	Storm #3										
Storm #1	Storm #2	Storm #3													
Rainfall	in														
Runoff, Q	in														

Worksheet 2: Runoff Curve Number and Runoff

(Use P and CN with table 2-1, fig. 2-1, or eqs. 2-3 and 2-4.)

Worksheet 2: Runoff Curve Number and Runoff

Project _____
 Location Naperville, Illinois

By KPB Date 3/16/2022
 Checked _____ Date _____

Circle one: Present Developed

RUNOFF AREA : 002

1. Runoff curve number (CN)

Soil Name and Hydrologic Group	Cover Description (cover type, treatment, and hydrologic condition; percent impervious; unconnected/connected impervious area ratio)	CN ^{1/}			Area <u>X</u> acres mi ² %	Product of CN x Area
		Table 2-2	Fig. 2-3	Fig. 2-4		
B	Grass (Open Space, Good)	61			0.56	34.16
C	Grass (Open Space, Good)	74			0.3	22.2
	Open Water (Pond at NWL)	98			0.66	64.68
Totals =					1.52	121.040

1/ Use only one CN source per line.

$$\text{CN (weighted) = } \frac{\text{Total Product}}{\text{Total Area}} = \frac{121.040}{1.520} = 79.632$$

Use CN = 79.6

2. Runoff

Frequency yr
 Rainfall in
 Runoff, Q in

Storm #1	Storm #2	Storm #3

(Use P and CN with table 2-1, fig. 2-1, or eqs. 2-3 and 2-4.)

Worksheet 2: Runoff Curve Number and Runoff

Project Location Naperville, Illinois

By KPB Date 3/16/2022
 Checked _____ Date _____

Circle one: Present Developed

RUNOFF AREA : 003

1. Runoff curve number (CN)

Soil Name and Hydrologic Group	Cover Description (cover type, treatment, and hydrologic condition; percent impervious; unconnected/connected impervious area ratio)	CN ^{1/}			Area <u>X</u> acres mi ² %	Product of CN x Area
		Table 2-2	Fig. 2-3	Fig. 2-4		
B	Grass (Open Space, Good)	61			0.12	7.32
C	Grass (Open Space, Good)	74			0.06	4.44
B	Gravel	85			0.03	2.55
C	Gravel	89			0.02	1.78
Totals =					0.23	16.090

1/ Use only one CN source per line.

$$\text{CN (weighted)} = \frac{\text{Total Product}}{\text{Total Area}} = \frac{16.090}{0.230} = 69.957$$

Use CN = 70.0

2. Runoff

Frequency yr
 Rainfall in
 Runoff, Q in
 (Use P and CN with table 2-1, fig. 2-1, or eqs. 2-3 and 2-4.)

Storm #1	Storm #2	Storm #3

Worksheet 2: Runoff Curve Number and Runoff

Project _____
 Location Naperville, Illinois

By KPB Date 3/16/2022
 Checked _____ Date _____

Circle one: Present Developed

RUNOFF AREA : 004

1. Runoff curve number (CN)

Soil Name and Hydrologic Group	Cover Description (cover type, treatment, and hydrologic condition; percent impervious; unconnected/connected impervious area ratio)	CN ^{1/}			Area X acres mi ² %	Product of CN x Area
		Table 2-2	Fig. 2-3	Fig. 2-4		
B	Grass (Open Space, Good)	61			0.26	15.86
C	Grass (Open Space, Good)	74			0.14	10.36
	Concrete Sidewalk	98			0.07	6.86
	Concrete Pavement	98			0.2	19.6
	Concrete Driveway	98			0.05	4.9
Totals =					0.72	57.580

1/ Use only one CN source per line.

$$\text{CN (weighted)} = \frac{\text{Total Product}}{\text{Total Area}} = \frac{57.580}{0.720} = 79.972$$

Use CN = 80.0

2. Runoff

Frequency yr
 Rainfall in
 Runoff, Q in
 (Use P and CN with table 2-1, fig. 2-1, or eqs. 2-3 and 2-4.)

Storm #1	Storm #2	Storm #3

Worksheet 2: Runoff Curve Number and Runoff

Project _____
 Location Naperville, Illinois

By KPB Date 3/16/2022
 Checked _____ Date _____

Circle one: Present Developed

RUNOFF AREA : 005

1. Runoff curve number (CN)

Soil Name and Hydrologic Group	Cover Description (cover type, treatment, and hydrologic condition; percent impervious; unconnected/connected impervious area ratio)	CN ^{1/}			Area <u>X</u> acres mi ² %	Product of CN x Area
		Table 2-2	Fig. 2-3	Fig. 2-4		
B	Grass (Open Space, Good)	61			0.42	25.62
C	Grass (Open Space, Good)	74			0.22	16.28
Totals =					0.64	41.900

1/ Use only one CN source per line.

$$\text{CN (weighted)} = \frac{\text{Total Product}}{\text{Total Area}} = \frac{41.900}{0.640} = 65.469$$

Use CN = 65.5

2. Runoff

Frequency yr
 Rainfall in
 Runoff, Q in
 (Use P and CN with table 2-1, fig. 2-1, or eqs. 2-3 and 2-4.)

Storm #1	Storm #2	Storm #3

Worksheet 2: Runoff Curve Number and Runoff

Project _____
 Location Naperville, Illinois

By KPB Date 3/16/2022
 Checked _____ Date _____

Circle one: Present Developed

RUNOFF AREA : 101

1. Runoff curve number (CN)

Soil Name and Hydrologic Group	Cover Description (cover type, treatment, and hydrologic condition; percent impervious; unconnected/connected impervious area ratio)	CN ^{1/}			Area	Product of CN x Area
		Table 2-2	Fig. 2-3	Fig. 2-4	<u>X</u> acres mi ² %	
B	Grass (Open Space, Good)	61			1.81	110.41
C	Grass (Open Space, Good)	74			0.96	71.04
	Asphalt Path	98			0.16	15.68
	Open Water (Creek at NWL)	98			0.01	0.98
Totals =					2.94	198.110

1/ Use only one CN source per line.

$$\text{CN (weighted)} = \frac{\text{Total Product}}{\text{Total Area}} = \frac{198.110}{2.940} = 67.384$$

Use CN = 67.4

2. Runoff

Frequency yr
 Rainfall in
 Runoff, Q in
 (Use P and CN with table 2-1, fig. 2-1, or eqs. 2-3 and 2-4.)

Storm #1	Storm #2	Storm #3

Worksheet 2: Runoff Curve Number and Runoff

Project Location Naperville, Illinois

By KPB Date 3/16/2022
 Checked _____ Date _____

Circle one: Present Developed

RUNOFF AREA : 102

1. Runoff curve number (CN)

Soil Name and Hydrologic Group	Cover Description (cover type, treatment, and hydrologic condition; percent impervious; unconnected/connected impervious area ratio)	CN ^{1/}			Area <u>X</u> acres mi ² %	Product of CN x Area
		Table 2-2	Fig. 2-3	Fig. 2-4		
B	Grass (Open Space, Good)	61			0.08	4.88
C	Grass (Open Space, Good)	74			0.05	3.7
Totals =					0.13	8.580

1/ Use only one CN source per line.

$$\text{CN (weighted)} = \frac{\text{Total Product}}{\text{Total Area}} = \frac{8.580}{0.130} = \underline{66.000}$$

Use CN = 66.0

2. Runoff

Frequency yr
 Rainfall in
 Runoff, Q in

(Use P and CN with table 2-1, fig. 2-1, or eqs. 2-3 and 2-4.)

Storm #1	Storm #2	Storm #3

Project _____
 Location Naperville, IL

By KPB Date 3/16/2022
 Checked _____ Date _____

Check one: Present Developed
 Check one: Tc Tt

Existing Condition
Subarea 001

NOTES: Space for as many as two segments per flow type can be used for each worksheet.
 Include a map, schematic, or description of flow segments.

Sheet Flow (Applicable to Tc only)

1. Surface Description (Table 3-1)
2. Manning's roughness coeff., n (Table 3-1)
3. Flow length, L (total L ≤ 300 ft)
4. Two-yr 24-hr rainfall, P₂
5. Land slope, s
6.
$$T_c = \frac{0.007 (nL)^{0.8}}{P_2^{0.5} s^{0.4}}$$

Segment ID		
	Dense Grass	
	0.24	
ft	100	
in	3.04	
ft/ft	0.04	
hr	0.185	+ = 0.185

Shallow Concentrated Flow

7. Surface description (paved or unpaved)
8. Flow length, L
9. Watercourse slope, s
10. Average velocity, V (figure 3-1)
11.
$$T_t = \frac{L}{3600 V}$$

Segment ID		
	unpaved	paved
	1093	
	0.008	
	1.45	
hr	0.209	+ = 0.209

Channel Flow

12. Cross sectional flow area, a
13. Wetted perimeter, pw
14. Hydraulic radius, r= a/pw compute r
15. Channel Slope, s
16. Manning's roughness coeff., n
17. $V = 1.49 r^{2/3} s^{1/2} / n$
18. Flow length, L
19.
$$T_t = \frac{L}{3600 V}$$

Segment ID		
ft ²		
ft		
ft		
ft/ft		
ft/s	3	
ft		
hr		+ =

20. Watershed or subarea T_c or T_t (add T_t in steps 6, 11, and 19) hr 0.394

Project _____
 Location Naperville, IL

By KPB Date 3/16/2022
 Checked _____ Date _____

Check one: Present Developed

Existing Condition

Check one: Tc Tt

Subarea 002

NOTES: Space for as many as two segments per flow type can be used for each worksheet.
 Include a map, schematic, or description of flow segments.

Sheet Flow (Applicable to Tc only)

1. Surface Description (Table 3-1)
2. Manning's roughness coeff., n (Table 3-1)
3. Flow length, L (total L ≤ 300 ft)
4. Two-yr 24-hr rainfall, P₂
5. Land slope, s

$$T_c = \frac{0.007 (nL)^{0.8}}{P_2^{0.5} s^{0.4}}$$

Segment ID		
	Dense Grass	
	0.24	
ft	92	
in	3.04	
ft/ft	0.01	
hr	0.301	+

= 0.301

Shallow Concentrated Flow

7. Surface description (paved or unpaved)
8. Flow length, L
9. Watercourse slope, s
10. Average velocity, V (figure 3-1)

$$T_t = \frac{L}{3600 V}$$

Segment ID		
	unpaved	paved
hr		+

=

Channel Flow

12. Cross sectional flow area, a
13. Wetted perimeter, pw
14. Hydraulic radius, r= a/pw compute r
15. Channel Slope, s
16. Manning's roughness coeff., n
17. $V = 1.49 r^{2/3} s^{1/2} / n$
18. Flow length, L

$$T_t = \frac{L}{3600 V}$$

Segment ID		
ft ²		
ft		
ft		
ft/ft		
ft/s	3	
ft		
hr		+

=

20. Watershed or subarea T_c or T_t (add T_t in steps 6, 11, and 19) hr 0.301

Project _____
 Location Naperville, IL

By KPB Date 3/16/2022
 Checked _____ Date _____

Check one: Present Developed
 Check one: Tc Tt

Existing Condition _____
 Subarea 003

NOTES: Space for as many as two segments per flow type can be used for each worksheet.
 Include a map, schematic, or description of flow segments.

Sheet Flow (Applicable to Tc only)

1. Surface Description (Table 3-1)
2. Manning's roughness coeff., n (Table 3-1)
3. Flow length, L (total L ≤ 300 ft)
4. Two-yr 24-hr rainfall, P₂
5. Land slope, s
6.
$$T_c = \frac{0.007 (nL)^{0.8}}{P_2^{0.5} s^{0.4}}$$

Segment ID		
	Dense Grass	
	0.24	
ft	74	
in	3.04	
ft/ft	0.02	
hr	0.192	+ = 0.192

Shallow Concentrated Flow

7. Surface description (paved or unpaved)
8. Flow length, L
9. Watercourse slope, s
10. Average velocity, V (figure 3-1)
11.
$$T_t = \frac{L}{3600 V}$$

Segment ID		
	unpaved	paved
hr		+ =

Channel Flow

12. Cross sectional flow area, a
13. Wetted perimeter, pw
14. Hydraulic radius, r = a/pw compute r
15. Channel Slope, s
16. Manning's roughness coeff., n
17. $V = 1.49 r^{2/3} s^{1/2} / n$
18. Flow length, L
19.
$$T_t = \frac{L}{3600 V}$$

Segment ID		
ft ²		
ft		
ft		
ft/ft		
ft/s	3	
ft		
hr		+ =

20. Watershed or subarea T_c or T_t (add T_t in steps 6, 11, and 19) hr 0.192

Project _____
 Location Naperville, IL

By KPB Date 3/16/2022
 Checked _____ Date _____

Check one: Present Developed
 Check one: Tc Tt

Existing Condition
Subarea 004

NOTES: Space for as many as two segments per flow type can be used for each worksheet.
 Include a map, schematic, or description of flow segments.

Sheet Flow (Applicable to Tc only)

1. Surface Description (Table 3-1)
2. Manning's roughness coeff., n (Table 3-1)
3. Flow length, L (total L ≤ 300 ft)
4. Two-yr 24-hr rainfall, P₂
5. Land slope, s
6.
$$T_c = \frac{0.007 (nL)^{0.8}}{P_2^{0.5} s^{0.4}}$$

Segment ID		
	Dense Grass	
	0.24	
ft	100	
in	3.04	
ft/ft	0.01	
hr	0.322	+ = 0.322

Shallow Concentrated Flow

7. Surface description (paved or unpaved)
8. Flow length, L
9. Watercourse slope, s
10. Average velocity, V (figure 3-1)
11.
$$T_t = \frac{L}{3600 V}$$

Segment ID		
	unpaved	paved
	75	
	0.01	
	1.63	
hr	0.013	+ = 0.013

Channel Flow

12. Cross sectional flow area, a
13. Wetted perimeter, pw
14. Hydraulic radius, r= a/pw compute r
15. Channel Slope, s
16. Manning's roughness coeff., n
17. $V = 1.49 r^{2/3} s^{1/2} / n$
18. Flow length, L
19.
$$T_t = \frac{L}{3600 V}$$

Segment ID		
ft ²		
ft		
ft		
ft/ft		
ft/s	3	
ft		
hr		+ =

20. Watershed or subarea T_c or T_t (add T_t in steps 6, 11, and 19) hr 0.335

Project _____
 Location Naperville, IL

By KPB Date 3/16/2022
 Checked _____ Date _____

Check one: Present Developed

Existing Condition

Check one: Tc Tt

Subarea 005

NOTES: Space for as many as two segments per flow type can be used for each worksheet.
 Include a map, schematic, or description of flow segments.

Sheet Flow (Applicable to Tc only)

1. Surface Description (Table 3-1)
2. Manning's roughness coeff., n (Table 3-1)
3. Flow length, L (total L ≤ 300 ft)
4. Two-yr 24-hr rainfall, P₂
5. Land slope, s

$$T_c = \frac{0.007 (nL)^{0.8}}{P_2^{0.5} s^{0.4}}$$

Segment ID		
	Dense Grass	
	0.24	
ft	100	
in	3.04	
ft/ft	0.07	
hr	0.148	+

= 0.148

Shallow Concentrated Flow

7. Surface description (paved or unpaved)
8. Flow length, L
9. Watercourse slope, s
10. Average velocity, V (figure 3-1)

$$T_t = \frac{L}{3600 V}$$

Segment ID		
	unpaved	paved
	137	
	0.45	
	11.01	
hr	0.003	+

= 0.003

Channel Flow

12. Cross sectional flow area, a
13. Wetted perimeter, pw
14. Hydraulic radius, r= a/pw compute r
15. Channel Slope, s
16. Manning's roughness coeff., n
17. $V = 1.49 r^{2/3} s^{1/2} / n$
18. Flow length, L

$$T_t = \frac{L}{3600 V}$$

Segment ID		
ft ²		
ft		
ft		
ft/ft		
ft/s	3	
ft		
hr		+

=

20. Watershed or subarea T_c or T_t (add T_t in steps 6, 11, and 19) hr 0.151

Project _____
 Location Naperville, IL

By KPB Date 3/16/2022
 Checked _____ Date _____

Check one: Present Developed
 Check one: Tc Tt

Existing Condition
Subarea 101

NOTES: Space for as many as two segments per flow type can be used for each worksheet.
 Include a map, schematic, or description of flow segments.

Sheet Flow (Applicable to Tc only)

1. Surface Description (Table 3-1)
2. Manning's roughness coeff., n (Table 3-1)
3. Flow length, L (total L ≤ 300 ft)
4. Two-yr 24-hr rainfall, P₂
5. Land slope, s
6.
$$T_c = \frac{0.007 (nL)^{0.8}}{P_2^{0.5} s^{0.4}}$$

Segment ID		
	Dense Grass	
	0.24	
ft	100	
in	3.04	
ft/ft	0.02	
hr	0.244	+ = 0.244

Shallow Concentrated Flow

7. Surface description (paved or unpaved)
8. Flow length, L
9. Watercourse slope, s
10. Average velocity, V (figure 3-1)
11.
$$T_t = \frac{L}{3600 V}$$

Segment ID	unpaved	paved
	68	
	0.02	
	2.30	
hr	0.008	+ = 0.008

Channel Flow

12. Cross sectional flow area, a
13. Wetted perimeter, pw
14. Hydraulic radius, r = a/pw compute r
15. Channel Slope, s
16. Manning's roughness coeff., n
17. $V = 1.49 r^{2/3} s^{1/2} / n$
18. Flow length, L
19.
$$T_t = \frac{L}{3600 V}$$

Segment ID		
ft ²		
ft		
ft		
ft/ft		
ft/s	3	
ft		
hr		+ =

20. Watershed or subarea T_c or T_t (add T_t in steps 6, 11, and 19) hr 0.252

Project _____
 Location Naperville, IL

By KPB Date 3/16/2022
 Checked _____ Date _____

Check one: Present Developed

Existing Condition _____

Check one: Tc Tt

Subarea 102

NOTES: Space for as many as two segments per flow type can be used for each worksheet.
 Include a map, schematic, or description of flow segments.

Sheet Flow (Applicable to Tc only)

1. Surface Description (Table 3-1)
2. Manning's roughness coeff., n (Table 3-1)
3. Flow length, L (total L ≤ 300 ft)
4. Two-yr 24-hr rainfall, P₂
5. Land slope, s

$$T_c = \frac{0.007 (nL)^{0.8}}{P_2^{0.5} s^{0.4}}$$

Segment ID		
	Dense Grass	
	0.24	
ft	71	
in	3.04	
ft/ft	0.02	
hr	0.186	+

= 0.186

Shallow Concentrated Flow

7. Surface description (paved or unpaved)
8. Flow length, L
9. Watercourse slope, s
10. Average velocity, V (figure 3-1)

$$T_t = \frac{L}{3600 V}$$

Segment ID		
	unpaved	paved
hr		+

=

Channel Flow

12. Cross sectional flow area, a
13. Wetted perimeter, pw
14. Hydraulic radius, r= a/pw compute r
15. Channel Slope, s
16. Manning's roughness coeff., n
17. V= 1.49 r^{2/3} s^{1/2} / n
18. Flow length, L

$$T_t = \frac{L}{3600 V}$$

Segment ID		
ft ²		
ft		
ft		
ft/ft		
ft/s	3	
ft		
hr		+

=

20. Watershed or subarea T_c or T_t (add T_t in steps 6, 11, and 19) hr 0.186

EXHIBIT K

EXISTING CONDITIONS

PONDPACK MODEL

Table of Contents

001	Unit Hydrograph Summary, 100 years	1
002	Unit Hydrograph Summary, 100 years	3
003	Unit Hydrograph Summary, 100 years	5
004	Unit Hydrograph Summary, 100 years	7
005	Unit Hydrograph Summary, 100 years	9
101	Unit Hydrograph Summary, 100 years	11
102	Unit Hydrograph Summary, 100 years	13
APN2	Unit Hydrograph Summary, 100 years	15
APN3	Unit Hydrograph Summary, 100 years	17
APN4	Unit Hydrograph Summary, 100 years	19
APN5	Unit Hydrograph Summary, 100 years	21
APN6	Unit Hydrograph Summary, 100 years	23
ASH4	Unit Hydrograph Summary, 100 years	25
CREEK OUTFALL 1	Read Hydrograph, 100 years	27
CREEK OUTFALL 2	Read Hydrograph, 100 years	33
PR1	Unit Hydrograph Summary, 100 years	39
PR2	Unit Hydrograph Summary, 100 years	41

Table of Contents

PR3	Unit Hydrograph Summary, 100 years	43
TAM1	Unit Hydrograph Summary, 100 years	45
TAM2	Unit Hydrograph Summary, 100 years	47
TAM3	Unit Hydrograph Summary, 100 years	49
TAM4	Unit Hydrograph Summary, 100 years	51
TAM5	Unit Hydrograph Summary, 100 years	53
TAM6	Unit Hydrograph Summary, 100 years	55
TAM7	Unit Hydrograph Summary, 100 years	57
CO-3	Channel Routing Summary, 100 years	59
CO-4	Channel Routing Summary, 100 years	60
APN3	Elevation-Area Volume Curve, 100 years	61
APN4	Elevation vs. Volume Curve, 100 years	62
APN5	Elevation-Area Volume Curve, 100 years	63
APN6	Elevation-Area Volume Curve, 100 years	64
On-Site Depressional Storage	Elevation vs. Volume Curve, 100 years	65
TAM1	Elevation vs. Volume Curve, 100 years	66
TAM2	Elevation vs. Volume Curve, 100 years	67

Table of Contents

TAM3	Elevation-Area Volume Curve, 100 years	68
TAM4	Elevation-Area Volume Curve, 100 years	69
TAM5	Elevation-Area Volume Curve, 100 years	70
TAM6	Elevation vs. Volume Curve, 100 years	71
TAM7	Elevation vs. Volume Curve, 100 years	72
West Tributary - Clow Creek	Elevation vs. Volume Curve, 100 years	73
APN3 Outlet	Outlet Input Data, 100 years	74
APN4 Outlet	Outlet Input Data, 100 years	78
APN5	Outlet Input Data, 100 years	81
APN6	Outlet Input Data, 100 years	83
Depressional Storage Overflow	Outlet Input Data, 100 years	86
TAM1	Outlet Input Data, 100 years	88
TAM2	Outlet Input Data, 100 years	91
TAM3	Outlet Input Data, 100 years	94
TAM4	Outlet Input Data, 100 years	97
TAM5	Outlet Input Data, 100 years	101
TAM6	Outlet Input Data, 100 years	104

Table of Contents

TAM7

Outlet Input Data, 100 years 107

West Tributary Offsite Flow

Outlet Input Data, 100 years 109

Subsection: Unit Hydrograph Summary
 Label: 001

Return Event: 100 years
 Storm Event: 100YR-24HR

Storm Event	100YR-24HR
Return Event	100 years
Duration	120.000 hours
Depth	8.6 in
Time of Concentration (Composite)	0.390 hours
Area (User Defined)	18.580 acres

Computational Time Increment	0.100 hours
Time to Peak (Computed)	16.000 hours
Flow (Peak, Computed)	11.29 ft ³ /s
Output Increment	0.100 hours
Time to Flow (Peak Interpolated Output)	16.000 hours
Flow (Peak Interpolated Output)	11.29 ft ³ /s

Drainage Area	
SCS CN (Composite)	70.800
Area (User Defined)	18.580 acres
Maximum Retention (Pervious)	4.1 in
Maximum Retention (Pervious, 20 percent)	0.8 in

Cumulative Runoff	
Cumulative Runoff Depth (Pervious)	5.1 in
Runoff Volume (Pervious)	7.825 ac-ft

Hydrograph Volume (Area under Hydrograph curve)	
Volume	7.825 ac-ft

SCS Unit Hydrograph Parameters	
Time of Concentration (Composite)	0.390 hours
Computational Time Increment	0.100 hours
Unit Hydrograph Shape Factor	483.432
K Factor	0.749
Receding/Rising, Tr/Tp	1.670
Unit peak, qp	49.42 ft ³ /s
Unit peak time, Tp	0.284 hours

Subsection: Unit Hydrograph Summary
Label: 001

Return Event: 100 years
Storm Event: 100YR-24HR

SCS Unit Hydrograph Parameters

Unit receding limb, Tr	1.136 hours
Total unit time, Tb	1.420 hours

Subsection: Unit Hydrograph Summary
 Label: 002

Return Event: 100 years
 Storm Event: 100YR-24HR

Storm Event	100YR-24HR
Return Event	100 years
Duration	120.000 hours
Depth	8.6 in
Time of Concentration (Composite)	0.300 hours
Area (User Defined)	1.520 acres

Computational Time Increment	0.100 hours
Time to Peak (Computed)	16.000 hours
Flow (Peak, Computed)	1.04 ft ³ /s
Output Increment	0.100 hours
Time to Flow (Peak Interpolated Output)	16.000 hours
Flow (Peak Interpolated Output)	1.04 ft ³ /s

Drainage Area	
SCS CN (Composite)	79.600
Area (User Defined)	1.520 acres
Maximum Retention (Pervious)	2.6 in
Maximum Retention (Pervious, 20 percent)	0.5 in

Cumulative Runoff	
Cumulative Runoff Depth (Pervious)	6.1 in
Runoff Volume (Pervious)	0.774 ac-ft

Hydrograph Volume (Area under Hydrograph curve)	
Volume	0.774 ac-ft

SCS Unit Hydrograph Parameters	
Time of Concentration (Composite)	0.300 hours
Computational Time Increment	0.100 hours
Unit Hydrograph Shape Factor	483.432
K Factor	0.749
Receding/Rising, Tr/Tp	1.670
Unit peak, qp	4.99 ft ³ /s
Unit peak time, Tp	0.230 hours

Subsection: Unit Hydrograph Summary
Label: 002

Return Event: 100 years
Storm Event: 100YR-24HR

SCS Unit Hydrograph Parameters

Unit receding limb, Tr	0.920 hours
Total unit time, Tb	1.150 hours

Subsection: Unit Hydrograph Summary
 Label: 003

Return Event: 100 years
 Storm Event: 100YR-24HR

Storm Event	100YR-24HR
Return Event	100 years
Duration	120.000 hours
Depth	8.6 in
Time of Concentration (Composite)	0.190 hours
Area (User Defined)	0.230 acres
Computational Time Increment	0.100 hours
Time to Peak (Computed)	16.000 hours
Flow (Peak, Computed)	0.14 ft ³ /s
Output Increment	0.100 hours
Time to Flow (Peak Interpolated Output)	16.000 hours
Flow (Peak Interpolated Output)	0.14 ft ³ /s
Drainage Area	
SCS CN (Composite)	70.000
Area (User Defined)	0.230 acres
Maximum Retention (Pervious)	4.3 in
Maximum Retention (Pervious, 20 percent)	0.9 in
Cumulative Runoff	
Cumulative Runoff Depth (Pervious)	5.0 in
Runoff Volume (Pervious)	0.095 ac-ft
Hydrograph Volume (Area under Hydrograph curve)	
Volume	0.095 ac-ft
SCS Unit Hydrograph Parameters	
Time of Concentration (Composite)	0.190 hours
Computational Time Increment	0.100 hours
Unit Hydrograph Shape Factor	483.432
K Factor	0.749
Receding/Rising, Tr/Tp	1.670
Unit peak, qp	1.06 ft ³ /s
Unit peak time, Tp	0.164 hours

Subsection: Unit Hydrograph Summary
Label: 003

Return Event: 100 years
Storm Event: 100YR-24HR

SCS Unit Hydrograph Parameters

Unit receding limb, Tr	0.656 hours
Total unit time, Tb	0.820 hours

Subsection: Unit Hydrograph Summary
 Label: 004

Return Event: 100 years
 Storm Event: 100YR-24HR

Storm Event	100YR-24HR
Return Event	100 years
Duration	120.000 hours
Depth	8.6 in
Time of Concentration (Composite)	0.340 hours
Area (User Defined)	0.720 acres

Computational Time Increment	0.100 hours
Time to Peak (Computed)	16.000 hours
Flow (Peak, Computed)	0.50 ft ³ /s
Output Increment	0.100 hours
Time to Flow (Peak Interpolated Output)	16.000 hours
Flow (Peak Interpolated Output)	0.50 ft ³ /s

Drainage Area	
SCS CN (Composite)	80.000
Area (User Defined)	0.720 acres
Maximum Retention (Pervious)	2.5 in
Maximum Retention (Pervious, 20 percent)	0.5 in

Cumulative Runoff	
Cumulative Runoff Depth (Pervious)	6.2 in
Runoff Volume (Pervious)	0.370 ac-ft

Hydrograph Volume (Area under Hydrograph curve)	
Volume	0.370 ac-ft

SCS Unit Hydrograph Parameters	
Time of Concentration (Composite)	0.340 hours
Computational Time Increment	0.100 hours
Unit Hydrograph Shape Factor	483.432
K Factor	0.749
Receding/Rising, Tr/Tp	1.670
Unit peak, qp	2.14 ft ³ /s
Unit peak time, Tp	0.254 hours

Subsection: Unit Hydrograph Summary
Label: 004

Return Event: 100 years
Storm Event: 100YR-24HR

SCS Unit Hydrograph Parameters

Unit receding limb, Tr	1.016 hours
Total unit time, Tb	1.270 hours

Subsection: Unit Hydrograph Summary
 Label: 005

Return Event: 100 years
 Storm Event: 100YR-24HR

Storm Event	100YR-24HR
Return Event	100 years
Duration	120.000 hours
Depth	8.6 in
Time of Concentration (Composite)	0.150 hours
Area (User Defined)	0.640 acres

Computational Time Increment	0.100 hours
Time to Peak (Computed)	16.000 hours
Flow (Peak, Computed)	0.36 ft ³ /s
Output Increment	0.100 hours
Time to Flow (Peak Interpolated Output)	16.000 hours
Flow (Peak Interpolated Output)	0.36 ft ³ /s

Drainage Area	
SCS CN (Composite)	65.500
Area (User Defined)	0.640 acres
Maximum Retention (Pervious)	5.3 in
Maximum Retention (Pervious, 20 percent)	1.1 in

Cumulative Runoff	
Cumulative Runoff Depth (Pervious)	4.4 in
Runoff Volume (Pervious)	0.236 ac-ft

Hydrograph Volume (Area under Hydrograph curve)	
Volume	0.236 ac-ft

SCS Unit Hydrograph Parameters	
Time of Concentration (Composite)	0.150 hours
Computational Time Increment	0.100 hours
Unit Hydrograph Shape Factor	483.432
K Factor	0.749
Receding/Rising, Tr/Tp	1.670
Unit peak, qp	3.45 ft ³ /s
Unit peak time, Tp	0.140 hours

Subsection: Unit Hydrograph Summary
Label: 005

Return Event: 100 years
Storm Event: 100YR-24HR

SCS Unit Hydrograph Parameters

Unit receding limb, Tr	0.560 hours
Total unit time, Tb	0.700 hours

Subsection: Unit Hydrograph Summary
 Label: 101

Return Event: 100 years
 Storm Event: 100YR-24HR

Storm Event	100YR-24HR
Return Event	100 years
Duration	120.000 hours
Depth	8.6 in
Time of Concentration (Composite)	0.250 hours
Area (User Defined)	2.940 acres

Computational Time Increment	0.100 hours
Time to Peak (Computed)	16.000 hours
Flow (Peak, Computed)	1.69 ft ³ /s
Output Increment	0.100 hours
Time to Flow (Peak Interpolated Output)	16.000 hours
Flow (Peak Interpolated Output)	1.69 ft ³ /s

Drainage Area	
SCS CN (Composite)	67.400
Area (User Defined)	2.940 acres
Maximum Retention (Pervious)	4.8 in
Maximum Retention (Pervious, 20 percent)	1.0 in

Cumulative Runoff	
Cumulative Runoff Depth (Pervious)	4.6 in
Runoff Volume (Pervious)	1.138 ac-ft

Hydrograph Volume (Area under Hydrograph curve)	
Volume	1.138 ac-ft

SCS Unit Hydrograph Parameters	
Time of Concentration (Composite)	0.250 hours
Computational Time Increment	0.100 hours
Unit Hydrograph Shape Factor	483.432
K Factor	0.749
Receding/Rising, Tr/Tp	1.670
Unit peak, qp	11.10 ft ³ /s
Unit peak time, Tp	0.200 hours

Subsection: Unit Hydrograph Summary
Label: 101

Return Event: 100 years
Storm Event: 100YR-24HR

SCS Unit Hydrograph Parameters

Unit receding limb, Tr	0.800 hours
Total unit time, Tb	1.000 hours

Subsection: Unit Hydrograph Summary
 Label: 102

Return Event: 100 years
 Storm Event: 100YR-24HR

Storm Event	100YR-24HR
Return Event	100 years
Duration	120.000 hours
Depth	8.6 in
Time of Concentration (Composite)	0.190 hours
Area (User Defined)	0.130 acres

Computational Time Increment	0.100 hours
Time to Peak (Computed)	16.000 hours
Flow (Peak, Computed)	0.07 ft ³ /s
Output Increment	0.100 hours
Time to Flow (Peak Interpolated Output)	16.000 hours
Flow (Peak Interpolated Output)	0.07 ft ³ /s

Drainage Area	
SCS CN (Composite)	66.000
Area (User Defined)	0.130 acres
Maximum Retention (Pervious)	5.2 in
Maximum Retention (Pervious, 20 percent)	1.0 in

Cumulative Runoff	
Cumulative Runoff Depth (Pervious)	4.5 in
Runoff Volume (Pervious)	0.049 ac-ft

Hydrograph Volume (Area under Hydrograph curve)	
Volume	0.049 ac-ft

SCS Unit Hydrograph Parameters	
Time of Concentration (Composite)	0.190 hours
Computational Time Increment	0.100 hours
Unit Hydrograph Shape Factor	483.432
K Factor	0.749
Receding/Rising, Tr/Tp	1.670
Unit peak, qp	0.60 ft ³ /s
Unit peak time, Tp	0.164 hours

Subsection: Unit Hydrograph Summary
Label: 102

Return Event: 100 years
Storm Event: 100YR-24HR

SCS Unit Hydrograph Parameters

Unit receding limb, Tr	0.656 hours
Total unit time, Tb	0.820 hours

Subsection: Unit Hydrograph Summary
 Label: APN2

Return Event: 100 years
 Storm Event: 100YR-24HR

Storm Event	100YR-24HR
Return Event	100 years
Duration	120.000 hours
Depth	8.6 in
Time of Concentration (Composite)	0.250 hours
Area (User Defined)	10.160 acres

Computational Time Increment	0.100 hours
Time to Peak (Computed)	16.000 hours
Flow (Peak, Computed)	6.47 ft ³ /s
Output Increment	0.100 hours
Time to Flow (Peak Interpolated Output)	16.000 hours
Flow (Peak Interpolated Output)	6.47 ft ³ /s

Drainage Area	
SCS CN (Composite)	73.600
Area (User Defined)	10.160 acres
Maximum Retention (Pervious)	3.6 in
Maximum Retention (Pervious, 20 percent)	0.7 in

Cumulative Runoff	
Cumulative Runoff Depth (Pervious)	5.4 in
Runoff Volume (Pervious)	4.564 ac-ft

Hydrograph Volume (Area under Hydrograph curve)	
Volume	4.564 ac-ft

SCS Unit Hydrograph Parameters	
Time of Concentration (Composite)	0.250 hours
Computational Time Increment	0.100 hours
Unit Hydrograph Shape Factor	483.432
K Factor	0.749
Receding/Rising, Tr/Tp	1.670
Unit peak, qp	38.37 ft ³ /s
Unit peak time, Tp	0.200 hours

Subsection: Unit Hydrograph Summary
Label: APN2

Return Event: 100 years
Storm Event: 100YR-24HR

SCS Unit Hydrograph Parameters

Unit receding limb, Tr	0.800 hours
Total unit time, Tb	1.000 hours

Subsection: Unit Hydrograph Summary
 Label: APN3

Return Event: 100 years
 Storm Event: 100YR-24HR

Storm Event	100YR-24HR
Return Event	100 years
Duration	120.000 hours
Depth	8.6 in
Time of Concentration (Composite)	0.533 hours
Area (User Defined)	49.690 acres

Computational Time Increment	0.100 hours
Time to Peak (Computed)	16.000 hours
Flow (Peak, Computed)	35.60 ft ³ /s
Output Increment	0.100 hours
Time to Flow (Peak Interpolated Output)	16.000 hours
Flow (Peak Interpolated Output)	35.60 ft ³ /s

Drainage Area	
SCS CN (Composite)	84.500
Area (User Defined)	49.690 acres
Maximum Retention (Pervious)	1.8 in
Maximum Retention (Pervious, 20 percent)	0.4 in

Cumulative Runoff	
Cumulative Runoff Depth (Pervious)	6.7 in
Runoff Volume (Pervious)	27.760 ac-ft

Hydrograph Volume (Area under Hydrograph curve)	
Volume	27.760 ac-ft

SCS Unit Hydrograph Parameters	
Time of Concentration (Composite)	0.533 hours
Computational Time Increment	0.100 hours
Unit Hydrograph Shape Factor	483.432
K Factor	0.749
Receding/Rising, Tr/Tp	1.670
Unit peak, qp	101.50 ft ³ /s
Unit peak time, Tp	0.370 hours

Subsection: Unit Hydrograph Summary
Label: APN3

Return Event: 100 years
Storm Event: 100YR-24HR

SCS Unit Hydrograph Parameters

Unit receding limb, Tr	1.479 hours
Total unit time, Tb	1.849 hours

Subsection: Unit Hydrograph Summary
 Label: APN4

Return Event: 100 years
 Storm Event: 100YR-24HR

Storm Event	100YR-24HR
Return Event	100 years
Duration	120.000 hours
Depth	8.6 in
Time of Concentration (Composite)	0.543 hours
Area (User Defined)	17.440 acres

Computational Time Increment	0.100 hours
Time to Peak (Computed)	16.000 hours
Flow (Peak, Computed)	12.12 ft ³ /s
Output Increment	0.100 hours
Time to Flow (Peak Interpolated Output)	16.000 hours
Flow (Peak Interpolated Output)	12.12 ft ³ /s

Drainage Area	
SCS CN (Composite)	81.300
Area (User Defined)	17.440 acres
Maximum Retention (Pervious)	2.3 in
Maximum Retention (Pervious, 20 percent)	0.5 in

Cumulative Runoff	
Cumulative Runoff Depth (Pervious)	6.3 in
Runoff Volume (Pervious)	9.182 ac-ft

Hydrograph Volume (Area under Hydrograph curve)	
Volume	9.182 ac-ft

SCS Unit Hydrograph Parameters	
Time of Concentration (Composite)	0.543 hours
Computational Time Increment	0.100 hours
Unit Hydrograph Shape Factor	483.432
K Factor	0.749
Receding/Rising, Tr/Tp	1.670
Unit peak, qp	35.05 ft ³ /s
Unit peak time, Tp	0.376 hours

Subsection: Unit Hydrograph Summary
Label: APN4

Return Event: 100 years
Storm Event: 100YR-24HR

SCS Unit Hydrograph Parameters

Unit receding limb, T_r	1.503 hours
Total unit time, T_b	1.879 hours

Subsection: Unit Hydrograph Summary
 Label: APN5

Return Event: 100 years
 Storm Event: 100YR-24HR

Storm Event	100YR-24HR
Return Event	100 years
Duration	120.000 hours
Depth	8.6 in
Time of Concentration (Composite)	0.595 hours
Area (User Defined)	40.530 acres

Computational Time Increment	0.100 hours
Time to Peak (Computed)	16.100 hours
Flow (Peak, Computed)	28.10 ft ³ /s
Output Increment	0.100 hours
Time to Flow (Peak Interpolated Output)	16.100 hours
Flow (Peak Interpolated Output)	28.10 ft ³ /s

Drainage Area	
SCS CN (Composite)	81.100
Area (User Defined)	40.530 acres
Maximum Retention (Pervious)	2.3 in
Maximum Retention (Pervious, 20 percent)	0.5 in

Cumulative Runoff	
Cumulative Runoff Depth (Pervious)	6.3 in
Runoff Volume (Pervious)	21.258 ac-ft

Hydrograph Volume (Area under Hydrograph curve)	
Volume	21.258 ac-ft

SCS Unit Hydrograph Parameters	
Time of Concentration (Composite)	0.595 hours
Computational Time Increment	0.100 hours
Unit Hydrograph Shape Factor	483.432
K Factor	0.749
Receding/Rising, Tr/Tp	1.670
Unit peak, qp	75.22 ft ³ /s
Unit peak time, Tp	0.407 hours

Subsection: Unit Hydrograph Summary
Label: APN5

Return Event: 100 years
Storm Event: 100YR-24HR

SCS Unit Hydrograph Parameters

Unit receding limb, Tr	1.628 hours
Total unit time, Tb	2.035 hours

Subsection: Unit Hydrograph Summary
 Label: APN6

Return Event: 100 years
 Storm Event: 100YR-24HR

Storm Event	100YR-24HR
Return Event	100 years
Duration	120.000 hours
Depth	8.6 in
Time of Concentration (Composite)	0.687 hours
Area (User Defined)	66.400 acres

Computational Time Increment	0.100 hours
Time to Peak (Computed)	16.100 hours
Flow (Peak, Computed)	42.34 ft ³ /s
Output Increment	0.100 hours
Time to Flow (Peak Interpolated Output)	16.100 hours
Flow (Peak Interpolated Output)	42.34 ft ³ /s

Drainage Area	
SCS CN (Composite)	74.400
Area (User Defined)	66.400 acres
Maximum Retention (Pervious)	3.4 in
Maximum Retention (Pervious, 20 percent)	0.7 in

Cumulative Runoff	
Cumulative Runoff Depth (Pervious)	5.5 in
Runoff Volume (Pervious)	30.359 ac-ft

Hydrograph Volume (Area under Hydrograph curve)	
Volume	30.359 ac-ft

SCS Unit Hydrograph Parameters	
Time of Concentration (Composite)	0.687 hours
Computational Time Increment	0.100 hours
Unit Hydrograph Shape Factor	483.432
K Factor	0.749
Receding/Rising, Tr/Tp	1.670
Unit peak, qp	108.52 ft ³ /s
Unit peak time, Tp	0.462 hours

Subsection: Unit Hydrograph Summary
Label: APN6

Return Event: 100 years
Storm Event: 100YR-24HR

SCS Unit Hydrograph Parameters

Unit receding limb, Tr	1.849 hours
Total unit time, Tb	2.311 hours

Subsection: Unit Hydrograph Summary
 Label: ASH4

Return Event: 100 years
 Storm Event: 100YR-24HR

Storm Event	100YR-24HR
Return Event	100 years
Duration	120.000 hours
Depth	8.6 in
Time of Concentration (Composite)	0.250 hours
Area (User Defined)	4.500 acres

Computational Time Increment	0.100 hours
Time to Peak (Computed)	16.000 hours
Flow (Peak, Computed)	3.15 ft ³ /s
Output Increment	0.100 hours
Time to Flow (Peak Interpolated Output)	16.000 hours
Flow (Peak Interpolated Output)	3.15 ft ³ /s

Drainage Area	
SCS CN (Composite)	81.600
Area (User Defined)	4.500 acres
Maximum Retention (Pervious)	2.3 in
Maximum Retention (Pervious, 20 percent)	0.5 in

Cumulative Runoff	
Cumulative Runoff Depth (Pervious)	6.4 in
Runoff Volume (Pervious)	2.383 ac-ft

Hydrograph Volume (Area under Hydrograph curve)	
Volume	2.383 ac-ft

SCS Unit Hydrograph Parameters	
Time of Concentration (Composite)	0.250 hours
Computational Time Increment	0.100 hours
Unit Hydrograph Shape Factor	483.432
K Factor	0.749
Receding/Rising, Tr/Tp	1.670
Unit peak, qp	17.00 ft ³ /s
Unit peak time, Tp	0.200 hours

Subsection: Unit Hydrograph Summary
Label: ASH4

Return Event: 100 years
Storm Event: 100YR-24HR

SCS Unit Hydrograph Parameters

Unit receding limb, Tr	0.800 hours
Total unit time, Tb	1.000 hours

Subsection: Read Hydrograph
 Label: CREEK OUTFALL 1

Return Event: 100 years
 Storm Event: 100YR-24HR

Peak Discharge	102.72 ft ³ /s
Time to Peak	21.400 hours
Hydrograph Volume	219.206 ac-ft

HYDROGRAPH ORDINATES (ft³/s)
Output Time Increment = 0.100 hours

Time on left represents time for first value in each row.

Time (hours)	Flow (ft ³ /s)	Flow (ft ³ /s)	Flow (ft ³ /s)	Flow (ft ³ /s)	Flow (ft ³ /s)
0.000	0.00	0.00	0.00	0.01	0.02
0.500	0.02	0.03	0.03	0.04	0.05
1.000	0.07	0.08	0.10	0.11	0.13
1.500	0.14	0.15	0.16	0.18	0.20
2.000	0.22	0.23	0.25	0.27	0.28
2.500	0.30	0.31	0.33	0.35	0.37
3.000	0.39	0.42	0.45	0.48	0.50
3.500	0.53	0.56	0.59	0.62	0.66
4.000	0.69	0.73	0.77	0.81	0.85
4.500	0.89	0.93	0.96	1.01	1.05
5.000	1.09	1.12	1.16	1.20	1.24
5.500	1.28	1.31	1.35	1.39	1.43
6.000	1.47	1.50	1.54	1.58	1.62
6.500	1.65	1.69	1.72	1.76	1.79
7.000	1.83	1.87	1.88	1.90	1.91
7.500	1.95	1.94	2.01	1.97	2.08
8.000	1.93	2.23	1.60	2.42	1.07
8.500	2.56	0.89	2.71	1.02	2.88
9.000	1.20	3.09	1.39	3.36	1.61
9.500	3.68	1.87	4.05	2.13	4.40
10.000	2.45	4.44	3.13	4.58	3.85
10.500	4.88	4.57	5.28	5.36	5.78
11.000	5.83	6.05	6.20	6.39	6.57
11.500	6.76	6.96	7.15	7.34	7.53
12.000	7.72	7.91	8.11	8.33	8.57
12.500	8.81	9.11	9.51	9.78	10.32
13.000	10.92	11.65	12.47	13.39	14.38
13.500	15.46	16.59	17.84	19.08	20.43
14.000	21.77	23.25	24.74	26.31	27.94
14.500	29.60	31.36	33.13	34.83	36.52
15.000	38.24	39.89	41.54	43.17	44.82
15.500	46.43	48.09	49.70	51.38	52.97
16.000	54.63	56.20	57.80	59.30	60.80
16.500	62.25	65.27	71.11	74.65	77.97
17.000	80.34	78.76	81.70	79.50	82.96
17.500	80.07	84.23	80.60	85.57	81.11
18.000	86.97	81.56	88.38	81.73	89.56
18.500	81.62	90.65	81.40	91.78	81.13
19.000	92.94	80.75	94.12	80.13	95.18

Subsection: Read Hydrograph
 Label: CREEK OUTFALL 1

Return Event: 100 years
 Storm Event: 100YR-24HR

HYDROGRAPH ORDINATES (ft³/s)
Output Time Increment = 0.100 hours
Time on left represents time for first value in each row.

Time (hours)	Flow (ft ³ /s)	Flow (ft ³ /s)	Flow (ft ³ /s)	Flow (ft ³ /s)	Flow (ft ³ /s)
19.500	79.27	96.19	78.29	97.27	77.19
20.000	98.36	76.12	99.41	74.93	100.30
20.500	73.55	101.04	72.25	101.67	71.09
21.000	102.25	70.06	102.59	69.28	102.72
21.500	68.67	102.72	68.20	102.65	67.86
22.000	102.55	67.59	102.44	67.37	102.29
22.500	67.17	102.10	67.04	101.91	66.94
23.000	101.71	66.86	101.52	66.77	101.33
23.500	66.66	101.14	66.56	100.95	66.46
24.000	100.77	66.36	100.53	66.06	100.06
24.500	65.63	99.44	65.29	98.75	64.96
25.000	98.08	64.64	97.40	64.39	96.72
25.500	64.21	96.03	64.02	95.36	63.77
26.000	94.72	63.53	94.07	63.35	93.41
26.500	63.20	92.74	63.05	92.09	62.93
27.000	88.97	66.43	84.01	70.79	78.46
27.500	72.35	74.68	72.24	72.39	71.29
28.000	70.85	70.09	69.50	68.87	68.31
28.500	67.76	67.24	66.73	66.24	65.76
29.000	65.28	64.81	64.33	63.86	63.38
29.500	62.91	62.67	62.59	62.43	62.30
30.000	62.14	61.98	61.82	61.64	61.47
30.500	61.29	61.12	60.95	60.76	60.58
31.000	60.39	60.20	60.01	59.82	59.63
31.500	59.43	59.23	59.03	58.84	58.66
32.000	58.48	58.29	58.10	57.90	57.71
32.500	57.51	57.30	57.09	56.88	56.68
33.000	56.49	56.30	56.11	55.92	55.72
33.500	55.52	55.31	55.09	54.85	54.60
34.000	54.35	54.11	53.88	53.66	53.45
34.500	53.23	53.01	52.76	52.50	52.22
35.000	51.94	51.67	51.40	51.14	50.88
35.500	50.64	50.41	50.16	49.91	49.64
36.000	49.38	49.09	48.81	48.54	48.27
36.500	48.02	47.79	47.56	47.32	47.05
37.000	46.76	46.47	46.20	45.93	45.67
37.500	45.42	45.19	44.96	44.72	44.46
38.000	44.18	43.89	43.61	43.34	43.09
38.500	42.86	42.64	42.43	42.21	41.98
39.000	41.72	41.46	41.19	40.92	40.65
39.500	40.40	40.15	39.93	39.74	39.56
40.000	39.36	39.13	38.86	38.57	38.28
40.500	38.00	37.74	37.49	37.26	37.05
41.000	36.84	36.61	36.36	36.09	35.79

Subsection: Read Hydrograph
 Label: CREEK OUTFALL 1

Return Event: 100 years
 Storm Event: 100YR-24HR

HYDROGRAPH ORDINATES (ft³/s)
Output Time Increment = 0.100 hours
Time on left represents time for first value in each row.

Time (hours)	Flow (ft ³ /s)	Flow (ft ³ /s)	Flow (ft ³ /s)	Flow (ft ³ /s)	Flow (ft ³ /s)
41.500	35.50	35.21	34.93	34.65	34.39
42.000	34.14	33.89	33.62	33.34	33.05
42.500	32.77	32.47	32.18	31.89	31.63
43.000	31.39	31.16	30.92	30.67	30.41
43.500	30.15	29.90	29.66	29.41	29.18
44.000	28.96	28.77	28.60	28.42	28.20
44.500	27.96	27.69	27.42	27.17	26.97
45.000	26.78	26.60	26.44	26.28	26.12
45.500	25.94	25.73	25.50	25.25	24.99
46.000	24.76	24.55	24.36	24.22	24.08
46.500	23.95	23.81	23.66	23.50	23.32
47.000	23.12	22.91	22.70	22.49	22.30
47.500	22.13	21.96	21.80	21.65	21.52
48.000	21.41	21.30	21.18	21.04	20.89
48.500	20.72	20.56	20.39	20.21	20.04
49.000	19.86	19.69	19.52	19.36	19.22
49.500	19.11	19.02	18.95	18.87	18.78
50.000	18.67	18.55	18.41	18.26	18.10
50.500	17.93	17.76	17.59	17.43	17.28
51.000	17.15	17.03	16.94	16.86	16.80
51.500	16.75	16.69	16.62	16.53	16.42
52.000	16.28	16.13	15.97	15.82	15.67
52.500	15.52	15.39	15.26	15.15	15.06
53.000	14.98	14.91	14.86	14.81	14.75
53.500	14.70	14.63	14.55	14.47	14.36
54.000	14.25	14.12	14.00	13.88	13.77
54.500	13.66	13.56	13.47	13.39	13.32
55.000	13.25	13.19	13.14	13.09	13.04
55.500	12.98	12.92	12.86	12.80	12.72
56.000	12.64	12.56	12.47	12.38	12.29
56.500	12.21	12.12	12.04	11.97	11.90
57.000	11.83	11.77	11.71	11.65	11.59
57.500	11.54	11.49	11.44	11.39	11.34
58.000	11.29	11.23	11.17	11.10	11.04
58.500	10.98	10.92	10.85	10.79	10.72
59.000	10.66	10.60	10.54	10.48	10.42
59.500	10.37	10.31	10.26	10.21	10.16
60.000	10.12	10.08	10.04	10.00	9.95
60.500	9.91	9.86	9.81	9.76	9.74
61.000	9.72	9.70	9.68	9.66	9.64
61.500	9.63	9.61	9.60	9.58	9.57
62.000	9.55	9.54	9.53	9.52	9.51
62.500	9.50	9.50	9.49	9.48	9.48
63.000	9.47	9.47	9.46	9.46	9.45

Subsection: Read Hydrograph
 Label: CREEK OUTFALL 1

Return Event: 100 years
 Storm Event: 100YR-24HR

HYDROGRAPH ORDINATES (ft³/s)
Output Time Increment = 0.100 hours
Time on left represents time for first value in each row.

Time (hours)	Flow (ft ³ /s)	Flow (ft ³ /s)	Flow (ft ³ /s)	Flow (ft ³ /s)	Flow (ft ³ /s)
63.500	9.45	9.44	9.44	9.43	9.42
64.000	9.42	9.41	9.40	9.40	9.39
64.500	9.38	9.37	9.36	9.35	9.34
65.000	9.34	9.33	9.32	9.31	9.30
65.500	9.30	9.29	9.28	9.28	9.27
66.000	9.26	9.26	9.25	9.24	9.24
66.500	9.23	9.23	9.22	9.22	9.21
67.000	9.21	9.21	9.20	9.20	9.19
67.500	9.19	9.19	9.18	9.18	9.18
68.000	9.17	9.17	9.17	9.16	9.16
68.500	9.16	9.15	9.15	9.15	9.14
69.000	9.14	9.14	9.14	9.13	9.13
69.500	9.13	9.12	9.12	9.12	9.12
70.000	9.11	9.11	9.11	9.11	9.10
70.500	9.10	9.10	9.10	9.09	9.09
71.000	9.09	9.09	9.08	9.08	9.08
71.500	9.08	9.07	9.07	9.07	9.06
72.000	9.06	9.06	9.06	9.05	9.05
72.500	9.05	9.05	9.05	9.04	9.04
73.000	9.04	9.04	9.03	9.03	9.03
73.500	9.03	9.03	9.40	9.47	9.53
74.000	9.58	9.62	9.65	9.69	9.73
74.500	9.77	9.83	9.89	9.94	9.99
75.000	10.03	10.08	10.12	10.04	9.91
75.500	9.75	9.65	9.58	9.52	9.46
76.000	9.42	9.38	9.35	9.32	9.29
76.500	9.27	9.25	9.23	9.22	9.21
77.000	9.20	9.19	9.18	9.17	9.16
77.500	9.16	9.15	9.14	9.13	9.13
78.000	9.12	9.11	9.11	9.10	9.10
78.500	9.09	9.09	9.08	9.08	9.07
79.000	9.07	9.06	9.06	9.05	9.05
79.500	9.04	9.04	9.03	9.03	9.03
80.000	9.02	9.02	9.01	9.01	9.00
80.500	9.00	8.99	8.99	8.98	8.98
81.000	8.97	8.97	8.96	8.95	8.95
81.500	8.94	8.94	8.93	8.93	8.93
82.000	8.92	8.91	8.91	8.90	8.89
82.500	8.89	8.88	8.87	8.87	8.86
83.000	8.85	8.84	8.84	8.83	8.82
83.500	8.81	8.81	8.80	8.79	8.78
84.000	8.78	8.77	8.76	8.75	8.75
84.500	8.74	8.73	8.73	8.72	8.71
85.000	8.71	8.70	8.69	8.69	8.68

Subsection: Read Hydrograph
 Label: CREEK OUTFALL 1

Return Event: 100 years
 Storm Event: 100YR-24HR

HYDROGRAPH ORDINATES (ft³/s)
Output Time Increment = 0.100 hours
Time on left represents time for first value in each row.

Time (hours)	Flow (ft ³ /s)	Flow (ft ³ /s)	Flow (ft ³ /s)	Flow (ft ³ /s)	Flow (ft ³ /s)
85.500	8.68	8.67	8.67	8.66	8.66
86.000	8.65	8.65	8.64	8.64	8.63
86.500	8.63	8.62	8.61	8.61	8.60
87.000	8.59	8.58	8.57	8.56	8.56
87.500	8.55	8.54	8.53	8.52	8.51
88.000	8.50	8.49	8.48	8.47	8.46
88.500	8.45	8.44	8.43	8.42	8.41
89.000	8.41	8.40	8.39	8.38	8.37
89.500	8.36	8.36	8.35	8.34	8.34
90.000	8.33	8.33	8.32	8.31	8.31
90.500	8.30	8.29	8.29	8.28	8.27
91.000	8.26	8.25	8.24	8.23	8.22
91.500	8.21	8.20	8.19	8.17	8.16
92.000	8.15	8.14	8.13	8.12	8.11
92.500	8.10	8.09	8.08	8.07	8.06
93.000	8.05	8.05	8.04	8.03	8.02
93.500	8.01	8.01	8.00	8.16	8.19
94.000	8.21	8.23	8.25	8.26	8.28
94.500	8.30	8.31	8.33	8.34	8.35
95.000	8.37	8.39	8.41	8.43	8.44
95.500	8.45	8.46	8.46	8.46	8.45
96.000	8.43	8.42	8.41	8.40	8.39
96.500	8.38	8.38	8.37	8.36	8.36
97.000	8.35	8.34	8.34	8.33	8.32
97.500	8.32	8.31	8.30	8.29	8.27
98.000	8.26	8.25	8.24	8.22	8.21
98.500	8.20	8.18	8.17	8.15	8.14
99.000	8.12	8.11	8.09	8.08	8.06
99.500	8.05	8.04	8.03	8.02	8.01
100.000	8.00	7.99	7.98	7.97	7.96
100.500	7.95	7.94	7.92	7.91	7.89
101.000	7.88	7.86	7.84	7.83	7.81
101.500	7.79	7.78	7.76	7.74	7.72
102.000	7.71	7.69	7.68	7.66	7.65
102.500	7.64	7.63	7.62	7.61	7.60
103.000	7.59	7.57	7.56	7.54	7.53
103.500	7.51	7.50	7.48	7.46	7.45
104.000	7.43	7.41	7.40	7.38	7.36
104.500	7.35	7.34	7.32	7.31	7.29
105.000	7.28	7.27	7.26	7.25	7.24
105.500	7.23	7.22	7.21	7.19	7.18
106.000	7.16	7.14	7.13	7.11	7.10
106.500	7.08	7.06	7.05	7.03	7.01
107.000	7.00	6.98	6.97	6.96	6.94

Subsection: Read Hydrograph
 Label: CREEK OUTFALL 1

Return Event: 100 years
 Storm Event: 100YR-24HR

HYDROGRAPH ORDINATES (ft³/s)
Output Time Increment = 0.100 hours
Time on left represents time for first value in each row.

Time (hours)	Flow (ft ³ /s)	Flow (ft ³ /s)	Flow (ft ³ /s)	Flow (ft ³ /s)	Flow (ft ³ /s)
107.500	6.93	6.92	6.91	6.90	6.89
108.000	6.88	6.87	6.86	6.84	6.83
108.500	6.82	6.80	6.79	6.77	6.76
109.000	6.74	6.73	6.71	6.69	6.68
109.500	6.66	6.65	6.63	6.61	6.60
110.000	6.58	6.57	6.56	6.54	6.53
110.500	6.52	6.51	6.50	6.49	6.48
111.000	6.47	6.46	6.44	6.43	6.41
111.500	6.40	6.38	6.36	6.35	6.33
112.000	6.31	6.30	6.28	6.26	6.24
112.500	6.23	6.21	6.19	6.18	6.38
113.000	6.39	6.43	6.46	6.49	6.52
113.500	6.54	6.56	6.59	6.61	6.64
114.000	6.66	6.69	6.70	6.72	6.73
114.500	6.73	6.73	6.73	6.73	6.72
115.000	6.72	6.71	6.71	6.71	6.70
115.500	6.70	6.69	6.69	6.68	6.68
116.000	6.67	6.66	6.65	6.64	6.62
116.500	6.61	6.59	6.58	6.56	6.55
117.000	6.54	6.52	6.51	6.50	6.48
117.500	6.47	6.45	6.43	6.41	6.39
118.000	6.37	6.35	6.32	6.30	6.28
118.500	6.25	6.23	6.21	6.19	6.16
119.000	6.15	6.13	6.11	6.10	6.08
119.500	6.06	6.05	6.03	6.01	5.98
120.000	5.96	(N/A)	(N/A)	(N/A)	(N/A)

Subsection: Read Hydrograph
 Label: CREEK OUTFALL 2

Return Event: 100 years
 Storm Event: 100YR-24HR

Peak Discharge	168.35 ft ³ /s
Time to Peak	0.100 hours
Hydrograph Volume	469.501 ac-ft

HYDROGRAPH ORDINATES (ft³/s)
Output Time Increment = 0.100 hours

Time on left represents time for first value in each row.

Time (hours)	Flow (ft ³ /s)	Flow (ft ³ /s)	Flow (ft ³ /s)	Flow (ft ³ /s)	Flow (ft ³ /s)
0.000	0.00	168.35	38.69	47.63	48.19
0.500	48.37	47.57	47.47	47.36	47.12
1.000	46.91	46.71	46.51	46.31	46.11
1.500	45.91	45.71	45.50	45.31	45.11
2.000	44.91	44.71	44.51	44.31	44.11
2.500	43.90	43.69	43.49	43.29	43.09
3.000	42.89	42.69	42.50	42.31	42.13
3.500	41.95	41.78	41.60	41.43	41.27
4.000	41.11	40.95	40.79	40.64	40.50
4.500	40.36	40.22	40.09	39.96	39.83
5.000	39.71	39.60	39.49	39.38	39.28
5.500	39.18	39.08	38.99	38.91	38.82
6.000	38.74	38.66	38.58	38.51	38.43
6.500	38.36	38.29	38.22	38.16	38.10
7.000	38.03	37.98	37.92	37.87	37.82
7.500	37.78	37.74	37.70	37.67	37.64
8.000	37.61	37.58	37.56	37.54	37.53
8.500	37.53	37.52	37.52	37.53	37.53
9.000	37.54	37.55	37.56	37.58	37.60
9.500	37.63	37.66	37.70	37.74	37.78
10.000	37.83	37.88	37.93	38.00	38.08
10.500	38.17	38.27	38.37	38.47	38.59
11.000	38.70	38.81	38.94	39.07	39.21
11.500	39.36	39.51	39.68	39.84	40.01
12.000	40.19	40.38	40.58	40.80	41.05
12.500	41.31	41.57	41.87	42.19	42.54
13.000	42.89	43.24	43.59	43.96	44.32
13.500	44.68	45.04	45.39	45.75	46.11
14.000	46.48	46.84	47.21	47.58	47.96
14.500	48.34	48.72	49.10	49.47	49.83
15.000	50.18	50.53	50.88	51.22	51.57
15.500	51.91	52.25	52.58	53.27	53.38
16.000	66.28	74.96	82.45	91.92	99.67
16.500	106.37	112.21	117.26	121.61	125.37
17.000	128.64	131.44	133.68	135.25	136.21
17.500	136.78	137.12	137.37	137.56	137.74
18.000	137.91	138.03	137.88	137.27	136.25
18.500	135.00	133.73	132.54	131.46	130.51
19.000	129.67	128.91	128.05	126.93	125.57

Subsection: Read Hydrograph
 Label: CREEK OUTFALL 2

Return Event: 100 years
 Storm Event: 100YR-24HR

HYDROGRAPH ORDINATES (ft³/s)
Output Time Increment = 0.100 hours
Time on left represents time for first value in each row.

Time (hours)	Flow (ft ³ /s)	Flow (ft ³ /s)	Flow (ft ³ /s)	Flow (ft ³ /s)	Flow (ft ³ /s)
19.500	124.11	122.69	121.38	120.19	119.13
20.000	118.20	117.34	116.42	115.32	114.04
20.500	112.70	111.40	110.20	109.11	108.12
21.000	107.25	106.45	105.68	104.85	103.99
21.500	103.12	102.30	101.55	100.86	100.24
22.000	99.69	99.19	98.71	98.22	97.73
22.500	97.26	96.82	96.43	96.07	95.75
23.000	95.49	95.24	95.01	94.78	94.56
23.500	94.35	94.16	93.99	93.83	93.68
24.000	93.55	93.39	93.02	92.30	91.26
24.500	90.07	88.85	87.68	86.59	85.58
25.000	84.69	83.88	83.17	82.53	81.96
25.500	81.55	81.20	80.87	80.57	80.29
26.000	80.02	79.77	79.53	79.29	79.06
26.500	78.83	78.62	78.41	78.20	78.00
27.000	77.79	77.59	77.39	77.19	76.99
27.500	76.80	76.61	76.42	76.25	76.07
28.000	75.90	75.74	75.58	75.42	75.26
28.500	75.11	74.96	74.81	74.66	74.52
29.000	74.38	74.25	74.11	73.98	73.85
29.500	73.72	73.59	73.46	73.32	73.18
30.000	73.03	72.86	72.68	72.50	72.30
30.500	72.09	71.87	71.65	71.42	71.18
31.000	70.94	70.69	70.44	70.18	69.93
31.500	69.67	69.40	69.14	68.87	68.60
32.000	68.33	68.06	67.78	67.51	67.23
32.500	66.96	66.68	66.40	66.12	65.69
33.000	65.02	64.15	63.17	62.09	61.31
33.500	60.60	59.84	59.05	58.24	57.42
34.000	56.59	55.51	54.19	52.97	52.79
34.500	52.74	52.67	52.61	52.54	52.48
35.000	52.41	52.35	52.28	52.22	52.15
35.500	52.09	52.02	51.96	51.89	51.82
36.000	51.76	51.69	51.63	51.56	51.49
36.500	51.43	51.36	51.30	51.23	51.17
37.000	51.10	51.04	50.97	50.91	50.84
37.500	50.78	50.71	50.65	50.58	50.52
38.000	50.45	50.39	50.33	50.26	50.20
38.500	50.14	50.08	50.01	49.95	49.89
39.000	49.83	49.77	49.71	49.65	49.59
39.500	49.53	49.47	49.41	49.35	49.28
40.000	49.22	49.16	49.10	49.04	48.98
40.500	48.92	48.86	48.80	48.74	48.68
41.000	48.62	48.56	48.50	48.44	48.38

Subsection: Read Hydrograph
 Label: CREEK OUTFALL 2

Return Event: 100 years
 Storm Event: 100YR-24HR

HYDROGRAPH ORDINATES (ft³/s)
Output Time Increment = 0.100 hours
Time on left represents time for first value in each row.

Time (hours)	Flow (ft ³ /s)	Flow (ft ³ /s)	Flow (ft ³ /s)	Flow (ft ³ /s)	Flow (ft ³ /s)
41.500	48.32	48.27	48.21	48.15	48.09
42.000	48.03	47.98	47.92	47.86	47.81
42.500	47.75	47.69	47.63	47.58	47.52
43.000	47.46	47.40	47.35	47.29	47.23
43.500	47.17	47.12	47.06	47.00	46.94
44.000	46.88	46.82	46.76	46.70	46.64
44.500	46.58	46.52	46.46	46.40	46.34
45.000	46.27	46.21	46.15	46.09	46.03
45.500	45.97	45.90	45.84	45.78	45.71
46.000	45.65	45.59	45.52	45.46	45.40
46.500	45.33	45.27	45.21	45.14	45.08
47.000	45.01	44.95	44.88	44.82	44.75
47.500	44.69	44.62	44.56	44.49	44.43
48.000	44.36	44.29	44.23	44.16	44.09
48.500	44.02	43.95	43.88	43.80	43.73
49.000	43.66	43.59	43.52	43.45	43.38
49.500	43.31	43.24	43.17	43.09	43.02
50.000	42.95	42.88	42.81	42.74	42.67
50.500	42.60	42.52	42.45	42.38	42.31
51.000	42.23	42.16	42.09	42.02	41.94
51.500	41.87	41.80	41.73	41.65	41.58
52.000	41.51	41.43	41.36	41.29	41.21
52.500	41.14	41.07	40.99	40.92	40.84
53.000	40.77	40.69	40.62	40.54	40.47
53.500	40.40	40.32	40.25	40.17	40.10
54.000	40.02	39.95	39.87	39.80	39.73
54.500	39.66	39.58	39.51	39.43	39.36
55.000	39.29	39.21	39.14	39.07	39.00
55.500	38.92	38.85	38.78	38.70	38.63
56.000	38.55	38.48	38.40	38.32	38.24
56.500	38.17	38.09	38.01	37.93	37.85
57.000	37.78	37.70	37.62	37.54	37.46
57.500	37.39	37.31	37.23	37.15	37.07
58.000	36.99	36.91	36.84	36.76	36.68
58.500	36.60	36.53	36.45	36.37	36.29
59.000	36.21	36.13	36.06	35.98	35.90
59.500	35.82	35.74	35.66	35.59	35.51
60.000	35.43	35.35	35.27	35.20	35.12
60.500	35.04	34.97	34.89	34.81	34.73
61.000	34.65	34.57	34.48	34.40	34.31
61.500	34.22	34.13	34.04	33.94	33.85
62.000	33.75	33.66	33.56	33.47	33.37
62.500	33.27	33.17	33.07	32.97	32.87
63.000	32.77	32.67	32.57	32.46	32.36

Subsection: Read Hydrograph
 Label: CREEK OUTFALL 2

Return Event: 100 years
 Storm Event: 100YR-24HR

HYDROGRAPH ORDINATES (ft³/s)
Output Time Increment = 0.100 hours
Time on left represents time for first value in each row.

Time (hours)	Flow (ft ³ /s)	Flow (ft ³ /s)	Flow (ft ³ /s)	Flow (ft ³ /s)	Flow (ft ³ /s)
63.500	32.26	32.15	32.05	31.94	31.83
64.000	31.72	31.61	31.50	31.39	31.28
64.500	31.16	31.05	30.94	30.83	30.71
65.000	30.59	30.48	30.36	30.25	30.13
65.500	30.01	29.90	29.78	29.66	29.54
66.000	29.42	29.31	29.19	29.07	28.95
66.500	28.82	28.70	28.58	28.45	28.33
67.000	28.21	28.09	27.97	27.84	27.72
67.500	27.60	27.48	27.35	27.23	27.11
68.000	26.99	26.86	26.74	26.62	26.50
68.500	26.38	26.26	26.14	26.01	25.89
69.000	25.77	25.64	25.52	25.40	25.28
69.500	25.16	25.04	24.92	24.80	24.68
70.000	24.56	24.44	24.32	24.20	24.08
70.500	23.95	23.83	23.71	23.59	23.47
71.000	23.35	23.23	23.11	22.99	22.87
71.500	22.75	22.63	22.51	22.39	22.28
72.000	22.16	22.05	21.92	21.80	21.68
72.500	21.55	21.43	21.31	21.19	21.08
73.000	20.96	21.32	21.50	21.78	22.05
73.500	165.84	151.45	40.21	52.85	51.80
74.000	51.32	51.08	51.02	50.83	50.63
74.500	50.46	50.29	50.11	49.93	49.76
75.000	49.59	49.41	49.23	49.05	48.88
75.500	48.72	48.56	48.41	48.26	48.11
76.000	47.96	47.81	47.65	47.50	47.35
76.500	47.20	47.05	46.90	46.74	46.59
77.000	46.44	46.29	46.13	45.98	45.83
77.500	45.67	45.52	45.37	45.22	45.06
78.000	44.91	44.76	44.60	44.45	44.30
78.500	44.14	43.97	43.81	43.64	43.48
79.000	43.32	43.16	42.99	42.83	42.66
79.500	42.50	42.34	42.17	42.01	41.85
80.000	41.68	41.52	41.35	41.19	41.03
80.500	40.86	40.70	40.53	40.37	40.21
81.000	40.04	39.88	39.72	39.56	39.40
81.500	39.24	39.08	38.92	38.75	38.59
82.000	38.43	38.26	38.09	37.92	37.76
82.500	37.59	37.42	37.25	37.09	36.92
83.000	36.75	36.59	36.42	36.25	36.09
83.500	35.92	35.76	35.59	35.43	35.26
84.000	35.10	34.94	34.77	34.61	34.45
84.500	34.29	34.12	33.96	33.80	33.64
85.000	33.48	33.32	33.16	33.00	32.84

Subsection: Read Hydrograph
 Label: CREEK OUTFALL 2

Return Event: 100 years
 Storm Event: 100YR-24HR

HYDROGRAPH ORDINATES (ft³/s)
Output Time Increment = 0.100 hours
Time on left represents time for first value in each row.

Time (hours)	Flow (ft ³ /s)	Flow (ft ³ /s)	Flow (ft ³ /s)	Flow (ft ³ /s)	Flow (ft ³ /s)
85.500	32.68	32.52	32.36	32.20	32.03
86.000	31.87	31.70	31.53	31.37	31.20
86.500	31.03	30.87	30.70	30.54	30.37
87.000	30.21	30.05	29.89	29.72	29.56
87.500	29.40	29.25	29.09	28.93	28.76
88.000	28.60	28.44	28.28	28.13	27.97
88.500	27.81	27.65	27.49	27.34	27.19
89.000	27.03	26.87	26.71	26.56	26.41
89.500	26.26	26.11	25.95	25.80	25.64
90.000	25.49	25.35	25.20	25.05	24.90
90.500	24.75	24.61	24.46	24.31	24.16
91.000	24.02	23.86	23.72	23.57	23.42
91.500	23.28	23.14	22.99	22.85	22.70
92.000	22.56	22.42	22.28	22.15	22.02
92.500	21.86	21.72	21.57	21.43	21.29
93.000	21.15	21.02	21.17	21.48	21.76
93.500	22.09	165.84	151.45	40.20	52.83
94.000	51.77	51.29	51.04	50.97	50.76
94.500	50.55	50.38	50.19	50.01	49.82
95.000	49.64	49.46	49.27	49.08	48.89
95.500	48.70	48.51	48.32	48.14	47.95
96.000	47.77	47.59	47.41	47.23	47.05
96.500	46.87	46.70	46.52	46.35	46.17
97.000	46.00	45.82	45.65	45.48	45.30
97.500	45.13	44.96	44.79	44.62	44.45
98.000	44.28	44.10	43.93	43.75	43.57
98.500	43.39	43.21	43.03	42.86	42.68
99.000	42.51	42.33	42.15	41.98	41.81
99.500	41.63	41.46	41.29	41.12	40.94
100.000	40.77	40.60	40.43	40.26	40.09
100.500	39.92	39.75	39.59	39.43	39.26
101.000	39.10	38.94	38.77	38.61	38.44
101.500	38.27	38.10	37.93	37.76	37.59
102.000	37.42	37.25	37.08	36.91	36.74
102.500	36.57	36.40	36.23	36.07	35.90
103.000	35.73	35.56	35.39	35.23	35.06
103.500	34.90	34.73	34.56	34.40	34.23
104.000	34.07	33.90	33.74	33.57	33.41
104.500	33.25	33.08	32.92	32.76	32.60
105.000	32.43	32.27	32.10	31.93	31.76
105.500	31.59	31.42	31.25	31.08	30.91
106.000	30.74	30.57	30.40	30.24	30.07
106.500	29.91	29.74	29.57	29.41	29.25
107.000	29.09	28.92	28.75	28.59	28.42

Subsection: Read Hydrograph
 Label: CREEK OUTFALL 2

Return Event: 100 years
 Storm Event: 100YR-24HR

HYDROGRAPH ORDINATES (ft³/s)
Output Time Increment = 0.100 hours
Time on left represents time for first value in each row.

Time (hours)	Flow (ft ³ /s)	Flow (ft ³ /s)	Flow (ft ³ /s)	Flow (ft ³ /s)	Flow (ft ³ /s)
107.500	28.26	28.10	27.94	27.77	27.61
108.000	27.45	27.29	27.13	26.97	26.81
108.500	26.65	26.49	26.33	26.18	26.02
109.000	25.86	25.70	25.55	25.39	25.24
109.500	25.09	24.93	24.78	24.63	24.47
110.000	24.32	24.17	24.01	23.86	23.70
110.500	23.55	23.40	23.25	23.11	22.95
111.000	22.80	22.65	22.51	22.36	22.22
111.500	22.08	21.93	21.77	21.63	21.48
112.000	21.33	21.18	21.04	21.11	21.47
112.500	21.74	22.09	165.84	151.45	40.19
113.000	52.83	51.76	51.27	51.02	50.95
113.500	50.74	50.53	50.35	50.16	49.97
114.000	49.78	49.60	49.41	49.22	49.02
114.500	48.82	48.63	48.44	48.24	48.05
115.000	47.85	47.66	47.47	47.28	47.09
115.500	46.89	46.70	46.51	46.32	46.13
116.000	45.95	45.76	45.57	45.39	45.21
116.500	45.03	44.85	44.67	44.49	44.31
117.000	44.13	43.95	43.76	43.58	43.39
117.500	43.21	43.03	42.85	42.66	42.49
118.000	42.30	42.12	41.95	41.77	41.59
118.500	41.41	41.23	41.06	40.88	40.70
119.000	40.53	40.36	40.18	40.01	39.83
119.500	39.67	39.50	39.33	39.16	38.99
120.000	38.83	(N/A)	(N/A)	(N/A)	(N/A)

Subsection: Unit Hydrograph Summary
 Label: PR1

Return Event: 100 years
 Storm Event: 100YR-24HR

Storm Event	100YR-24HR
Return Event	100 years
Duration	120.000 hours
Depth	8.6 in
Time of Concentration (Composite)	0.250 hours
Area (User Defined)	19.700 acres

Computational Time Increment	0.100 hours
Time to Peak (Computed)	16.000 hours
Flow (Peak, Computed)	13.93 ft ³ /s
Output Increment	0.100 hours
Time to Flow (Peak Interpolated Output)	16.000 hours
Flow (Peak Interpolated Output)	13.93 ft ³ /s

Drainage Area	
SCS CN (Composite)	82.600
Area (User Defined)	19.700 acres
Maximum Retention (Pervious)	2.1 in
Maximum Retention (Pervious, 20 percent)	0.4 in

Cumulative Runoff	
Cumulative Runoff Depth (Pervious)	6.5 in
Runoff Volume (Pervious)	10.630 ac-ft

Hydrograph Volume (Area under Hydrograph curve)	
Volume	10.630 ac-ft

SCS Unit Hydrograph Parameters	
Time of Concentration (Composite)	0.250 hours
Computational Time Increment	0.100 hours
Unit Hydrograph Shape Factor	483.432
K Factor	0.749
Receding/Rising, Tr/Tp	1.670
Unit peak, qp	74.40 ft ³ /s
Unit peak time, Tp	0.200 hours

Subsection: Unit Hydrograph Summary
Label: PR1

Return Event: 100 years
Storm Event: 100YR-24HR

SCS Unit Hydrograph Parameters	
Unit receding limb, Tr	0.800 hours
Total unit time, Tb	1.000 hours

Subsection: Unit Hydrograph Summary
 Label: PR2

Return Event: 100 years
 Storm Event: 100YR-24HR

Storm Event	100YR-24HR
Return Event	100 years
Duration	120.000 hours
Depth	8.6 in
Time of Concentration (Composite)	0.250 hours
Area (User Defined)	9.710 acres

Computational Time Increment	0.100 hours
Time to Peak (Computed)	16.000 hours
Flow (Peak, Computed)	6.87 ft ³ /s
Output Increment	0.100 hours
Time to Flow (Peak Interpolated Output)	16.000 hours
Flow (Peak Interpolated Output)	6.87 ft ³ /s

Drainage Area	
SCS CN (Composite)	82.600
Area (User Defined)	9.710 acres
Maximum Retention (Pervious)	2.1 in
Maximum Retention (Pervious, 20 percent)	0.4 in

Cumulative Runoff	
Cumulative Runoff Depth (Pervious)	6.5 in
Runoff Volume (Pervious)	5.239 ac-ft

Hydrograph Volume (Area under Hydrograph curve)	
Volume	5.239 ac-ft

SCS Unit Hydrograph Parameters	
Time of Concentration (Composite)	0.250 hours
Computational Time Increment	0.100 hours
Unit Hydrograph Shape Factor	483.432
K Factor	0.749
Receding/Rising, Tr/Tp	1.670
Unit peak, qp	36.67 ft ³ /s
Unit peak time, Tp	0.200 hours

Subsection: Unit Hydrograph Summary
Label: PR2

Return Event: 100 years
Storm Event: 100YR-24HR

SCS Unit Hydrograph Parameters

Unit receding limb, Tr	0.800 hours
Total unit time, Tb	1.000 hours

Subsection: Unit Hydrograph Summary
 Label: PR3

Return Event: 100 years
 Storm Event: 100YR-24HR

Storm Event	100YR-24HR
Return Event	100 years
Duration	120.000 hours
Depth	8.6 in
Time of Concentration (Composite)	0.250 hours
Area (User Defined)	5.830 acres

Computational Time Increment	0.100 hours
Time to Peak (Computed)	16.000 hours
Flow (Peak, Computed)	4.12 ft ³ /s
Output Increment	0.100 hours
Time to Flow (Peak Interpolated Output)	16.000 hours
Flow (Peak Interpolated Output)	4.12 ft ³ /s

Drainage Area	
SCS CN (Composite)	82.600
Area (User Defined)	5.830 acres
Maximum Retention (Pervious)	2.1 in
Maximum Retention (Pervious, 20 percent)	0.4 in

Cumulative Runoff	
Cumulative Runoff Depth (Pervious)	6.5 in
Runoff Volume (Pervious)	3.146 ac-ft

Hydrograph Volume (Area under Hydrograph curve)	
Volume	3.146 ac-ft

SCS Unit Hydrograph Parameters	
Time of Concentration (Composite)	0.250 hours
Computational Time Increment	0.100 hours
Unit Hydrograph Shape Factor	483.432
K Factor	0.749
Receding/Rising, Tr/Tp	1.670
Unit peak, qp	22.02 ft ³ /s
Unit peak time, Tp	0.200 hours

Subsection: Unit Hydrograph Summary
Label: PR3

Return Event: 100 years
Storm Event: 100YR-24HR

SCS Unit Hydrograph Parameters

Unit receding limb, Tr	0.800 hours
Total unit time, Tb	1.000 hours

Subsection: Unit Hydrograph Summary
 Label: TAM1

Return Event: 100 years
 Storm Event: 100YR-24HR

Storm Event	100YR-24HR
Return Event	100 years
Duration	120.000 hours
Depth	8.6 in
Time of Concentration (Composite)	0.476 hours
Area (User Defined)	140.350 acres

Computational Time Increment	0.100 hours
Time to Peak (Computed)	16.000 hours
Flow (Peak, Computed)	96.74 ft ³ /s
Output Increment	0.100 hours
Time to Flow (Peak Interpolated Output)	16.000 hours
Flow (Peak Interpolated Output)	96.74 ft ³ /s

Drainage Area	
SCS CN (Composite)	80.400
Area (User Defined)	140.350 acres
Maximum Retention (Pervious)	2.4 in
Maximum Retention (Pervious, 20 percent)	0.5 in

Cumulative Runoff	
Cumulative Runoff Depth (Pervious)	6.2 in
Runoff Volume (Pervious)	72.626 ac-ft

Hydrograph Volume (Area under Hydrograph curve)	
Volume	72.626 ac-ft

SCS Unit Hydrograph Parameters	
Time of Concentration (Composite)	0.476 hours
Computational Time Increment	0.100 hours
Unit Hydrograph Shape Factor	483.432
K Factor	0.749
Receding/Rising, Tr/Tp	1.670
Unit peak, qp	315.90 ft ³ /s
Unit peak time, Tp	0.336 hours

Subsection: Unit Hydrograph Summary
Label: TAM1

Return Event: 100 years
Storm Event: 100YR-24HR

SCS Unit Hydrograph Parameters

Unit receding limb, Tr	1.342 hours
Total unit time, Tb	1.678 hours

Subsection: Unit Hydrograph Summary
 Label: TAM2

Return Event: 100 years
 Storm Event: 100YR-24HR

Storm Event	100YR-24HR
Return Event	100 years
Duration	120.000 hours
Depth	8.6 in
Time of Concentration (Composite)	0.229 hours
Area (User Defined)	6.720 acres

Computational Time Increment	0.100 hours
Time to Peak (Computed)	16.000 hours
Flow (Peak, Computed)	4.82 ft ³ /s
Output Increment	0.100 hours
Time to Flow (Peak Interpolated Output)	16.000 hours
Flow (Peak Interpolated Output)	4.82 ft ³ /s

Drainage Area	
SCS CN (Composite)	84.100
Area (User Defined)	6.720 acres
Maximum Retention (Pervious)	1.9 in
Maximum Retention (Pervious, 20 percent)	0.4 in

Cumulative Runoff	
Cumulative Runoff Depth (Pervious)	6.7 in
Runoff Volume (Pervious)	3.727 ac-ft

Hydrograph Volume (Area under Hydrograph curve)	
Volume	3.727 ac-ft

SCS Unit Hydrograph Parameters	
Time of Concentration (Composite)	0.229 hours
Computational Time Increment	0.100 hours
Unit Hydrograph Shape Factor	483.432
K Factor	0.749
Receding/Rising, Tr/Tp	1.670
Unit peak, qp	27.09 ft ³ /s
Unit peak time, Tp	0.187 hours

Subsection: Unit Hydrograph Summary
Label: TAM2

Return Event: 100 years
Storm Event: 100YR-24HR

SCS Unit Hydrograph Parameters

Unit receding limb, Tr	0.750 hours
Total unit time, Tb	0.937 hours

Subsection: Unit Hydrograph Summary
 Label: TAM3

Return Event: 100 years
 Storm Event: 100YR-24HR

Storm Event	100YR-24HR
Return Event	100 years
Duration	120.000 hours
Depth	8.6 in
Time of Concentration (Composite)	0.320 hours
Area (User Defined)	10.130 acres

Computational Time Increment	0.100 hours
Time to Peak (Computed)	16.000 hours
Flow (Peak, Computed)	7.19 ft ³ /s
Output Increment	0.100 hours
Time to Flow (Peak Interpolated Output)	16.000 hours
Flow (Peak Interpolated Output)	7.19 ft ³ /s

Drainage Area	
SCS CN (Composite)	83.200
Area (User Defined)	10.130 acres
Maximum Retention (Pervious)	2.0 in
Maximum Retention (Pervious, 20 percent)	0.4 in

Cumulative Runoff	
Cumulative Runoff Depth (Pervious)	6.5 in
Runoff Volume (Pervious)	5.527 ac-ft

Hydrograph Volume (Area under Hydrograph curve)	
Volume	5.527 ac-ft

SCS Unit Hydrograph Parameters	
Time of Concentration (Composite)	0.320 hours
Computational Time Increment	0.100 hours
Unit Hydrograph Shape Factor	483.432
K Factor	0.749
Receding/Rising, Tr/Tp	1.670
Unit peak, qp	31.62 ft ³ /s
Unit peak time, Tp	0.242 hours

Subsection: Unit Hydrograph Summary
Label: TAM3

Return Event: 100 years
Storm Event: 100YR-24HR

SCS Unit Hydrograph Parameters	
Unit receding limb, Tr	0.968 hours
Total unit time, Tb	1.210 hours

Subsection: Unit Hydrograph Summary
 Label: TAM4

Return Event: 100 years
 Storm Event: 100YR-24HR

Storm Event	100YR-24HR
Return Event	100 years
Duration	120.000 hours
Depth	8.6 in
Time of Concentration (Composite)	0.720 hours
Area (User Defined)	60.500 acres

Computational Time Increment	0.100 hours
Time to Peak (Computed)	16.100 hours
Flow (Peak, Computed)	42.56 ft ³ /s
Output Increment	0.100 hours
Time to Flow (Peak Interpolated Output)	16.100 hours
Flow (Peak Interpolated Output)	42.56 ft ³ /s

Drainage Area	
SCS CN (Composite)	82.700
Area (User Defined)	60.500 acres
Maximum Retention (Pervious)	2.1 in
Maximum Retention (Pervious, 20 percent)	0.4 in

Cumulative Runoff	
Cumulative Runoff Depth (Pervious)	6.5 in
Runoff Volume (Pervious)	32.705 ac-ft

Hydrograph Volume (Area under Hydrograph curve)	
Volume	32.705 ac-ft

SCS Unit Hydrograph Parameters	
Time of Concentration (Composite)	0.720 hours
Computational Time Increment	0.100 hours
Unit Hydrograph Shape Factor	483.432
K Factor	0.749
Receding/Rising, Tr/Tp	1.670
Unit peak, qp	94.81 ft ³ /s
Unit peak time, Tp	0.482 hours

Subsection: Unit Hydrograph Summary
Label: TAM4

Return Event: 100 years
Storm Event: 100YR-24HR

SCS Unit Hydrograph Parameters

Unit receding limb, Tr	1.928 hours
Total unit time, Tb	2.410 hours

Subsection: Unit Hydrograph Summary
 Label: TAM5

Return Event: 100 years
 Storm Event: 100YR-24HR

Storm Event	100YR-24HR
Return Event	100 years
Duration	120.000 hours
Depth	8.6 in
Time of Concentration (Composite)	0.407 hours
Area (User Defined)	8.840 acres

Computational Time Increment	0.100 hours
Time to Peak (Computed)	16.000 hours
Flow (Peak, Computed)	6.45 ft ³ /s
Output Increment	0.100 hours
Time to Flow (Peak Interpolated Output)	16.000 hours
Flow (Peak Interpolated Output)	6.45 ft ³ /s

Drainage Area	
SCS CN (Composite)	86.700
Area (User Defined)	8.840 acres
Maximum Retention (Pervious)	1.5 in
Maximum Retention (Pervious, 20 percent)	0.3 in

Cumulative Runoff	
Cumulative Runoff Depth (Pervious)	7.0 in
Runoff Volume (Pervious)	5.134 ac-ft

Hydrograph Volume (Area under Hydrograph curve)	
Volume	5.134 ac-ft

SCS Unit Hydrograph Parameters	
Time of Concentration (Composite)	0.407 hours
Computational Time Increment	0.100 hours
Unit Hydrograph Shape Factor	483.432
K Factor	0.749
Receding/Rising, Tr/Tp	1.670
Unit peak, qp	22.70 ft ³ /s
Unit peak time, Tp	0.294 hours

Subsection: Unit Hydrograph Summary
Label: TAM5

Return Event: 100 years
Storm Event: 100YR-24HR

SCS Unit Hydrograph Parameters

Unit receding limb, T_r	1.177 hours
Total unit time, T_b	1.471 hours

Subsection: Unit Hydrograph Summary
 Label: TAM6

Return Event: 100 years
 Storm Event: 100YR-24HR

Storm Event	100YR-24HR
Return Event	100 years
Duration	120.000 hours
Depth	8.6 in
Time of Concentration (Composite)	0.338 hours
Area (User Defined)	25.630 acres

Computational Time Increment	0.100 hours
Time to Peak (Computed)	16.000 hours
Flow (Peak, Computed)	16.35 ft ³ /s
Output Increment	0.100 hours
Time to Flow (Peak Interpolated Output)	16.000 hours
Flow (Peak Interpolated Output)	16.35 ft ³ /s

Drainage Area	
SCS CN (Composite)	73.900
Area (User Defined)	25.630 acres
Maximum Retention (Pervious)	3.5 in
Maximum Retention (Pervious, 20 percent)	0.7 in

Cumulative Runoff	
Cumulative Runoff Depth (Pervious)	5.4 in
Runoff Volume (Pervious)	11.590 ac-ft

Hydrograph Volume (Area under Hydrograph curve)	
Volume	11.590 ac-ft

SCS Unit Hydrograph Parameters	
Time of Concentration (Composite)	0.338 hours
Computational Time Increment	0.100 hours
Unit Hydrograph Shape Factor	483.432
K Factor	0.749
Receding/Rising, Tr/Tp	1.670
Unit peak, qp	76.58 ft ³ /s
Unit peak time, Tp	0.253 hours

Subsection: Unit Hydrograph Summary
Label: TAM6

Return Event: 100 years
Storm Event: 100YR-24HR

SCS Unit Hydrograph Parameters

Unit receding limb, Tr	1.011 hours
Total unit time, Tb	1.264 hours

Subsection: Unit Hydrograph Summary
 Label: TAM7

Return Event: 100 years
 Storm Event: 100YR-24HR

Storm Event	100YR-24HR
Return Event	100 years
Duration	120.000 hours
Depth	8.6 in
Time of Concentration (Composite)	0.649 hours
Area (User Defined)	74.300 acres

Computational Time Increment	0.100 hours
Time to Peak (Computed)	16.100 hours
Flow (Peak, Computed)	50.65 ft ³ /s
Output Increment	0.100 hours
Time to Flow (Peak Interpolated Output)	16.100 hours
Flow (Peak Interpolated Output)	50.65 ft ³ /s

Drainage Area	
SCS CN (Composite)	79.600
Area (User Defined)	74.300 acres
Maximum Retention (Pervious)	2.6 in
Maximum Retention (Pervious, 20 percent)	0.5 in

Cumulative Runoff	
Cumulative Runoff Depth (Pervious)	6.1 in
Runoff Volume (Pervious)	37.850 ac-ft

Hydrograph Volume (Area under Hydrograph curve)	
Volume	37.850 ac-ft

SCS Unit Hydrograph Parameters	
Time of Concentration (Composite)	0.649 hours
Computational Time Increment	0.100 hours
Unit Hydrograph Shape Factor	483.432
K Factor	0.749
Receding/Rising, Tr/Tp	1.670
Unit peak, qp	127.73 ft ³ /s
Unit peak time, Tp	0.439 hours

Subsection: Unit Hydrograph Summary
Label: TAM7

Return Event: 100 years
Storm Event: 100YR-24HR

SCS Unit Hydrograph Parameters

Unit receding limb, Tr	1.758 hours
Total unit time, Tb	2.197 hours

Subsection: Channel Routing Summary
 Label: CO-3

Return Event: 100 years
 Storm Event: 100YR-24HR

Infiltration	
Infiltration Method	No Infiltration
Translation Routing Summary	
Flow (Base)	0.00 ft ³ /s
Translate	0.100 hours

	Inflow Hydrograph	Outflow Hydrograph
Time Start (hours)...	0.000	0.100
Time Step (hours)...	0.100	0.100
Time End (hours)...	120.000	120.100
Peak Time (hours)...	16.000	16.100
Peak Flow (ft ³ /s)...	28.07	28.07

Inflow/Outflow Volumes	
Volume (Routing, Inflow)	714.668 ac-ft
Volume (Routing, Unrouted)	0.000 ac-ft
Volume (Routing, Base Flow)	0.000 ac-ft
Volume (Routing, Infiltration)	0.000 ac-ft
Volume (Routing, Outflow)	714.668 ac-ft

Subsection: Channel Routing Summary
 Label: CO-4

Return Event: 100 years
 Storm Event: 100YR-24HR

Infiltration	
Infiltration Method	No Infiltration
Translation Routing Summary	
Flow (Base)	0.00 ft ³ /s
Translate	0.100 hours

	Inflow Hydrograph	Outflow Hydrograph
Time Start (hours)...	0.000	0.100
Time Step (hours)...	0.100	0.100
Time End (hours)...	120.000	120.100
Peak Time (hours)...	16.000	16.100
Peak Flow (ft ³ /s)...	28.07	28.07

Inflow/Outflow Volumes	
Volume (Routing, Inflow)	21.397 ac-ft
Volume (Routing, Unrouted)	0.000 ac-ft
Volume (Routing, Base Flow)	0.000 ac-ft
Volume (Routing, Infiltration)	0.000 ac-ft
Volume (Routing, Outflow)	21.397 ac-ft

Subsection: Elevation-Area Volume Curve
 Label: APN3

Return Event: 100 years
 Storm Event: 100YR-24HR

Elevation (ft)	Planimeter (ft ²)	Area (acres)	A1+A2+sqr (A1*A2) (acres)	Volume (ac-ft)	Volume (Total) (ac-ft)
680.00	0.0	0.000	0.000	0.000	0.000
681.00	0.0	2.633	2.633	0.878	0.878
682.00	0.0	5.528	11.976	3.992	4.870
683.00	0.0	8.586	21.003	7.001	11.871
684.00	0.0	11.815	30.473	10.158	22.028
685.00	0.0	15.256	40.497	13.499	35.527
685.80	0.0	18.207	50.129	13.368	48.895
686.00	0.0	18.979	55.775	3.718	52.614
687.00	0.0	23.049	62.943	20.981	73.595

Subsection: Elevation vs. Volume Curve
Label: APN4

Return Event: 100 years
Storm Event: 100YR-24HR

Elevation-Volume

Pond Elevation (ft)	Pond Volume (ac-ft)
680.20	0.000
682.00	1.096
684.00	2.577
686.00	4.611
688.00	7.610

Subsection: Elevation-Area Volume Curve
 Label: APN5

Return Event: 100 years
 Storm Event: 100YR-24HR

Elevation (ft)	Planimeter (ft ²)	Area (acres)	A1+A2+sqr (A1*A2) (acres)	Volume (ac-ft)	Volume (Total) (ac-ft)
676.90	0.0	0.000	0.000	0.000	0.000
678.00	0.0	1.610	1.610	0.590	0.590
680.00	0.0	5.298	9.829	6.552	7.143
682.00	0.0	10.085	22.693	15.128	22.271

Subsection: Elevation-Area Volume Curve
 Label: APN6

Return Event: 100 years
 Storm Event: 100YR-24HR

Elevation (ft)	Planimeter (ft ²)	Area (acres)	A1+A2+sqr (A1*A2) (acres)	Volume (ac-ft)	Volume (Total) (ac-ft)
667.50	0.0	0.000	0.000	0.000	0.000
668.00	0.0	2.622	2.622	0.437	0.437
670.00	0.0	13.345	21.882	14.588	15.025
672.00	0.0	23.978	55.211	36.807	51.833
674.00	0.0	38.438	92.775	61.850	113.683

Subsection: Elevation vs. Volume Curve
Label: On-Site Depressional Storage

Return Event: 100 years
Storm Event: 100YR-24HR

Elevation-Volume

Pond Elevation (ft)	Pond Volume (ac-ft)
650.10	0.000
651.00	0.061
652.00	1.320
653.00	2.072
654.00	2.871
655.00	3.815
655.50	4.375

Subsection: Elevation vs. Volume Curve
Label: TAM1

Return Event: 100 years
Storm Event: 100YR-24HR

Elevation-Volume

Pond Elevation (ft)	Pond Volume (ac-ft)
659.00	0.000
660.00	3.402
661.00	7.246
662.00	11.543
664.00	22.246
666.00	36.781
668.00	60.318

Subsection: Elevation vs. Volume Curve
Label: TAM2

Return Event: 100 years
Storm Event: 100YR-24HR

Elevation-Volume

Pond Elevation (ft)	Pond Volume (ac-ft)
662.40	0.000
664.00	1.196
666.00	3.102
668.00	5.660

Subsection: Elevation-Area Volume Curve
 Label: TAM3

Return Event: 100 years
 Storm Event: 100YR-24HR

Elevation (ft)	Planimeter (ft ²)	Area (acres)	A1+A2+sqr (A1*A2) (acres)	Volume (ac-ft)	Volume (Total) (ac-ft)
661.50	0.0	0.000	0.000	0.000	0.000
662.00	0.0	0.460	0.460	0.077	0.077
664.00	0.0	2.672	4.241	2.827	2.904
666.00	0.0	5.510	12.019	8.013	10.916
668.00	0.0	9.258	21.910	14.607	25.523

Subsection: Elevation-Area Volume Curve
 Label: TAM4

Return Event: 100 years
 Storm Event: 100YR-24HR

Elevation (ft)	Planimeter (ft ²)	Area (acres)	A1+A2+sqr (A1*A2) (acres)	Volume (ac-ft)	Volume (Total) (ac-ft)
660.00	0.0	0.000	0.000	0.000	0.000
662.00	0.0	7.246	7.246	4.831	4.831
664.00	0.0	15.270	33.035	22.023	26.854
666.00	0.0	24.411	58.988	39.325	66.179

Subsection: Elevation-Area Volume Curve
 Label: TAM5

Return Event: 100 years
 Storm Event: 100YR-24HR

Elevation (ft)	Planimeter (ft ²)	Area (acres)	A1+A2+sqr (A1*A2) (acres)	Volume (ac-ft)	Volume (Total) (ac-ft)
657.00	0.0	0.000	0.000	0.000	0.000
658.00	0.0	1.413	1.413	0.471	0.471
660.00	0.0	4.701	8.691	5.794	6.265
662.00	0.0	8.592	19.648	13.099	19.364

Subsection: Elevation vs. Volume Curve
Label: TAM6

Return Event: 100 years
Storm Event: 100YR-24HR

Elevation-Volume

Pond Elevation (ft)	Pond Volume (ac-ft)
653.00	0.000
654.00	0.257
656.00	1.110
658.00	4.651
660.00	11.414
662.00	20.228

Subsection: Elevation vs. Volume Curve
Label: TAM7

Return Event: 100 years
Storm Event: 100YR-24HR

Elevation-Volume

Pond Elevation (ft)	Pond Volume (ac-ft)
650.00	0.000
652.00	5.146
654.00	11.134
656.00	18.412
658.00	29.988

Subsection: Elevation vs. Volume Curve
Label: West Tributary - Clow Creek

Return Event: 100 years
Storm Event: 100YR-24HR

Elevation-Volume

Pond Elevation (ft)	Pond Volume (ac-ft)
647.00	0.000
648.00	0.012
649.00	0.036
650.00	0.169
651.00	0.438
652.00	0.767
653.00	1.944
654.00	5.617
655.00	12.280

Subsection: Outlet Input Data
 Label: APN3 Outlet

Return Event: 100 years
 Storm Event: 100YR-24HR

Requested Pond Water Surface Elevations	
Minimum (Headwater)	680.00 ft
Increment (Headwater)	0.10 ft
Maximum (Headwater)	687.00 ft

Outlet Connectivity

Structure Type	Outlet ID	Direction	Outfall	E1 (ft)	E2 (ft)
Culvert-Circular	Culvert - 1	Forward + Reverse	TW	681.80	687.00
Culvert-Circular	Culvert - 2	Forward + Reverse	TW	680.00	681.80
Irregular Weir	Weir - 1	Forward + Reverse	TW	686.10	687.00
Tailwater Settings	Tailwater			(N/A)	(N/A)

Subsection: Outlet Input Data
 Label: APN3 Outlet

Return Event: 100 years
 Storm Event: 100YR-24HR

Structure ID: Culvert - 1	
Structure Type: Culvert-Circular	
Number of Barrels	1
Diameter	15.0 in
Length	109.00 ft
Length (Computed Barrel)	109.00 ft
Slope (Computed)	0.008 ft/ft
Outlet Control Data	
Manning's n	0.013
Ke	0.200
Kb	0.023
Kr	0.000
Convergence Tolerance	0.00 ft
Inlet Control Data	
Equation Form	Form 1
K	0.0045
M	2.0000
C	0.0317
Y	0.6900
T1 ratio (HW/D)	0.000
T2 ratio (HW/D)	1.193
Slope Correction Factor	-0.500

Use unsubmerged inlet control 0 equation below T1 elevation.
 Use submerged inlet control 0 equation above T2 elevation

In transition zone between unsubmerged and submerged inlet control, interpolate between flows at T1 & T2...

T1 Elevation	676.96 ft	T1 Flow	4.80 ft ³ /s
T2 Elevation	678.45 ft	T2 Flow	5.49 ft ³ /s

Subsection: Outlet Input Data
 Label: APN3 Outlet

Return Event: 100 years
 Storm Event: 100YR-24HR

Structure ID: Culvert - 2	
Structure Type: Culvert-Circular	
Number of Barrels	1
Diameter	24.0 in
Length	376.00 ft
Length (Computed Barrel)	376.01 ft
Slope (Computed)	0.008 ft/ft
Outlet Control Data	
Manning's n	0.013
Ke	0.200
Kb	0.012
Kr	0.000
Convergence Tolerance	0.00 ft
Inlet Control Data	
Equation Form	Form 1
K	0.0045
M	2.0000
C	0.0317
Y	0.6900
T1 ratio (HW/D)	0.000
T2 ratio (HW/D)	1.193
Slope Correction Factor	-0.500

Use unsubmerged inlet control 0 equation below T1 elevation.
 Use submerged inlet control 0 equation above T2 elevation

In transition zone between unsubmerged and submerged inlet control, interpolate between flows at T1 & T2...

T1 Elevation	680.00 ft	T1 Flow	15.55 ft ³ /s
T2 Elevation	682.39 ft	T2 Flow	17.77 ft ³ /s

Subsection: Outlet Input Data
Label: APN3 Outlet

Return Event: 100 years
Storm Event: 100YR-24HR

Structure ID: Weir - 1
Structure Type: Irregular Weir

Station (ft)	Elevation (ft)
0.00	687.00
15.00	686.10
55.00	686.40
120.00	687.00

Lowest Elevation 686.10 ft
Weir Coefficient 3.00 (ft^{0.5})/s

Subsection: Outlet Input Data
 Label: APN4 Outlet

Return Event: 100 years
 Storm Event: 100YR-24HR

Requested Pond Water Surface Elevations	
Minimum (Headwater)	680.20 ft
Increment (Headwater)	0.10 ft
Maximum (Headwater)	688.00 ft

Outlet Connectivity

Structure Type	Outlet ID	Direction	Outfall	E1 (ft)	E2 (ft)
Culvert-Circular	Culvert - 1	Forward + Reverse	TW	680.20	688.00
Rectangular Weir	Weir - 1	Forward + Reverse	TW	686.50	688.00
Tailwater Settings	Tailwater			(N/A)	(N/A)

Subsection: Outlet Input Data
 Label: APN4 Outlet

Return Event: 100 years
 Storm Event: 100YR-24HR

Structure ID: Culvert - 1	
Structure Type: Culvert-Circular	
Number of Barrels	1
Diameter	12.0 in
Length	368.00 ft
Length (Computed Barrel)	368.01 ft
Slope (Computed)	0.007 ft/ft
Outlet Control Data	
Manning's n	0.013
Ke	0.200
Kb	0.031
Kr	0.000
Convergence Tolerance	0.00 ft
Inlet Control Data	
Equation Form	Form 1
K	0.0045
M	2.0000
C	0.0317
Y	0.6900
T1 ratio (HW/D)	1.092
T2 ratio (HW/D)	1.194
Slope Correction Factor	-0.500

Use unsubmerged inlet control 0 equation below T1 elevation.
 Use submerged inlet control 0 equation above T2 elevation

In transition zone between unsubmerged and submerged inlet control, interpolate between flows at T1 & T2...

T1 Elevation	681.29 ft	T1 Flow	2.75 ft ³ /s
T2 Elevation	681.39 ft	T2 Flow	3.14 ft ³ /s

Subsection: Outlet Input Data
Label: APN4 Outlet

Return Event: 100 years
Storm Event: 100YR-24HR

Structure ID: Weir - 1	
Structure Type: Rectangular Weir	
<hr/>	
Number of Openings	1
Elevation	686.50 ft
Weir Length	34.00 ft
Weir Coefficient	3.00 (ft ^{0.5})/s

Subsection: Outlet Input Data
Label: APN5

Return Event: 100 years
Storm Event: 100YR-24HR

Requested Pond Water Surface Elevations	
Minimum (Headwater)	676.90 ft
Increment (Headwater)	0.10 ft
Maximum (Headwater)	682.00 ft

Outlet Connectivity

Structure Type	Outlet ID	Direction	Outfall	E1 (ft)	E2 (ft)
Orifice-Circular	Orifice - 1	Forward + Reverse	TW	676.93	682.00
Rectangular Weir	Weir - 1	Forward + Reverse	TW	681.00	682.00
Tailwater Settings	Tailwater			(N/A)	(N/A)

Subsection: Outlet Input Data
Label: APN5

Return Event: 100 years
Storm Event: 100YR-24HR

Structure ID: Orifice - 1	
Structure Type: Orifice-Circular	
<hr/>	
Number of Openings	1
Elevation	676.93 ft
Orifice Diameter	12.0 in
Orifice Coefficient	0.600
<hr/>	
Structure ID: Weir - 1	
Structure Type: Rectangular Weir	
<hr/>	
Number of Openings	1
Elevation	681.00 ft
Weir Length	75.00 ft
Weir Coefficient	3.00 (ft ^{0.5})/s
<hr/>	

Subsection: Outlet Input Data
 Label: APN6

Return Event: 100 years
 Storm Event: 100YR-24HR

Requested Pond Water Surface Elevations	
Minimum (Headwater)	667.50 ft
Increment (Headwater)	0.10 ft
Maximum (Headwater)	674.00 ft

Outlet Connectivity

Structure Type	Outlet ID	Direction	Outfall	E1 (ft)	E2 (ft)
Culvert-Circular	Culvert - 1	Forward + Reverse	TW	667.52	674.00
Rectangular Weir	Weir - 1	Forward + Reverse	TW	673.00	674.00
Tailwater Settings	Tailwater			(N/A)	(N/A)

Subsection: Outlet Input Data
 Label: APN6

Return Event: 100 years
 Storm Event: 100YR-24HR

Structure ID: Culvert - 1	
Structure Type: Culvert-Circular	
Number of Barrels	1
Diameter	18.0 in
Length	57.00 ft
Length (Computed Barrel)	57.01 ft
Slope (Computed)	0.019 ft/ft
Outlet Control Data	
Manning's n	0.013
Ke	0.200
Kb	0.018
Kr	0.000
Convergence Tolerance	0.00 ft
Inlet Control Data	
Equation Form	Form 1
K	0.0045
M	2.0000
C	0.0317
Y	0.6900
T1 ratio (HW/D)	1.086
T2 ratio (HW/D)	1.188
Slope Correction Factor	-0.500

Use unsubmerged inlet control 0 equation below T1 elevation.

Use submerged inlet control 0 equation above T2 elevation

In transition zone between unsubmerged and submerged inlet control, interpolate between flows at T1 & T2...

T1 Elevation	669.15 ft	T1 Flow	7.58 ft ³ /s
T2 Elevation	669.30 ft	T2 Flow	8.66 ft ³ /s

Subsection: Outlet Input Data
Label: APN6

Return Event: 100 years
Storm Event: 100YR-24HR

Structure ID: Weir - 1	
Structure Type: Rectangular Weir	
<hr/>	
Number of Openings	1
Elevation	673.00 ft
Weir Length	110.00 ft
Weir Coefficient	3.00 (ft ^{0.5})/s

Subsection: Outlet Input Data
 Label: Depressional Storage Overflow

Return Event: 100 years
 Storm Event: 100YR-24HR

Requested Pond Water Surface Elevations	
Minimum (Headwater)	650.10 ft
Increment (Headwater)	0.50 ft
Maximum (Headwater)	655.50 ft

Outlet Connectivity

Structure Type	Outlet ID	Direction	Outfall	E1 (ft)	E2 (ft)
Irregular Weir	Weir - 1	Forward + Reverse	TW	654.70	655.50
Tailwater Settings	Tailwater			(N/A)	(N/A)

Subsection: Outlet Input Data
Label: Depressional Storage Overflow

Return Event: 100 years
Storm Event: 100YR-24HR

Structure ID: Weir - 1
Structure Type: Irregular Weir

Station (ft)	Elevation (ft)
0.00	655.50
59.00	655.00
110.00	654.70
199.00	655.00
217.00	655.50

Lowest Elevation 654.70 ft
Weir Coefficient 3.00 (ft^{0.5})/s

Subsection: Outlet Input Data
 Label: TAM1

Return Event: 100 years
 Storm Event: 100YR-24HR

Requested Pond Water Surface Elevations	
Minimum (Headwater)	657.00 ft
Increment (Headwater)	0.10 ft
Maximum (Headwater)	668.00 ft

Outlet Connectivity

Structure Type	Outlet ID	Direction	Outfall	E1 (ft)	E2 (ft)
Culvert-Circular	Culvert - East	Forward + Reverse	TW	659.00	668.00
Culvert-Circular	Culvert - West	Forward + Reverse	TW	659.00	668.00
Rectangular Weir	Weir - 1	Forward + Reverse	TW	667.00	668.00
Tailwater Settings	Tailwater			(N/A)	(N/A)

Subsection: Outlet Input Data
 Label: TAM1

Return Event: 100 years
 Storm Event: 100YR-24HR

Structure ID: Culvert - West	
Structure Type: Culvert-Circular	
Number of Barrels	1
Diameter	66.0 in
Length	98.00 ft
Length (Computed Barrel)	98.00 ft
Slope (Computed)	0.006 ft/ft
Outlet Control Data	
Manning's n	0.013
Ke	0.200
Kb	0.003
Kr	0.000
Convergence Tolerance	0.00 ft
Inlet Control Data	
Equation Form	Form 1
K	0.0045
M	2.0000
C	0.0317
Y	0.6900
T1 ratio (HW/D)	1.092
T2 ratio (HW/D)	1.194
Slope Correction Factor	-0.500

Use unsubmerged inlet control 0 equation below T1 elevation.
 Use submerged inlet control 0 equation above T2 elevation

In transition zone between unsubmerged and submerged inlet control, interpolate between flows at T1 & T2...

T1 Elevation	665.01 ft	T1 Flow	195.01 ft ³ /s
T2 Elevation	665.57 ft	T2 Flow	222.87 ft ³ /s

Subsection: Outlet Input Data
 Label: TAM1

Return Event: 100 years
 Storm Event: 100YR-24HR

Structure ID: Weir - 1	
Structure Type: Rectangular Weir	
Number of Openings	1
Elevation	667.00 ft
Weir Length	200.00 ft
Weir Coefficient	3.00 (ft ^{0.5})/s

Structure ID: Culvert - East	
Structure Type: Culvert-Circular	
Number of Barrels	1
Diameter	66.0 in
Length	97.00 ft
Length (Computed Barrel)	97.00 ft
Slope (Computed)	0.004 ft/ft

Outlet Control Data	
Manning's n	0.013
Ke	0.200
Kb	0.003
Kr	0.000
Convergence Tolerance	0.00 ft

Inlet Control Data	
Equation Form	Form 1
K	0.0045
M	2.0000
C	0.0317
Y	0.6900
T1 ratio (HW/D)	1.093
T2 ratio (HW/D)	1.195
Slope Correction Factor	-0.500

Use unsubmerged inlet control 0 equation below T1 elevation.
 Use submerged inlet control 0 equation above T2 elevation

In transition zone between unsubmerged and submerged inlet control, interpolate between flows at T1 & T2...

T1 Elevation	665.01 ft	T1 Flow	195.01 ft ³ /s
T2 Elevation	665.57 ft	T2 Flow	222.87 ft ³ /s

Subsection: Outlet Input Data
 Label: TAM2

Return Event: 100 years
 Storm Event: 100YR-24HR

Requested Pond Water Surface Elevations	
Minimum (Headwater)	662.40 ft
Increment (Headwater)	0.10 ft
Maximum (Headwater)	668.00 ft

Outlet Connectivity

Structure Type	Outlet ID	Direction	Outfall	E1 (ft)	E2 (ft)
Culvert-Circular	Culvert - 1	Forward + Reverse	TW	662.40	668.00
Rectangular Weir	Weir - 1	Forward + Reverse	TW	667.00	668.00
Tailwater Settings	Tailwater			(N/A)	(N/A)

Subsection: Outlet Input Data
 Label: TAM2

Return Event: 100 years
 Storm Event: 100YR-24HR

Structure ID: Culvert - 1	
Structure Type: Culvert-Circular	
Number of Barrels	1
Diameter	36.0 in
Length	240.00 ft
Length (Computed Barrel)	240.00 ft
Slope (Computed)	0.004 ft/ft
Outlet Control Data	
Manning's n	0.013
Ke	0.200
Kb	0.007
Kr	0.000
Convergence Tolerance	0.00 ft
Inlet Control Data	
Equation Form	Form 1
K	0.0045
M	2.0000
C	0.0317
Y	0.6900
T1 ratio (HW/D)	1.093
T2 ratio (HW/D)	1.195
Slope Correction Factor	-0.500

Use unsubmerged inlet control 0 equation below T1 elevation.

Use submerged inlet control 0 equation above T2 elevation

In transition zone between unsubmerged and submerged inlet control, interpolate between flows at T1 & T2...

T1 Elevation	665.68 ft	T1 Flow	42.85 ft ³ /s
T2 Elevation	665.99 ft	T2 Flow	48.97 ft ³ /s

Subsection: Outlet Input Data
Label: TAM2

Return Event: 100 years
Storm Event: 100YR-24HR

Structure ID: Weir - 1	
Structure Type: Rectangular Weir	
<hr/>	
Number of Openings	1
Elevation	667.00 ft
Weir Length	26.00 ft
Weir Coefficient	3.00 (ft ^{0.5})/s

Subsection: Outlet Input Data
 Label: TAM3

Return Event: 100 years
 Storm Event: 100YR-24HR

Requested Pond Water Surface Elevations	
Minimum (Headwater)	661.50 ft
Increment (Headwater)	0.10 ft
Maximum (Headwater)	668.00 ft

Outlet Connectivity

Structure Type	Outlet ID	Direction	Outfall	E1 (ft)	E2 (ft)
Culvert-Circular	Culvert - 1	Forward + Reverse	TW	661.50	668.00
Rectangular Weir	Weir - 1	Forward + Reverse	TW	667.00	668.00
Tailwater Settings	Tailwater			(N/A)	(N/A)

Subsection: Outlet Input Data
 Label: TAM3

Return Event: 100 years
 Storm Event: 100YR-24HR

Structure ID: Culvert - 1	
Structure Type: Culvert-Circular	
Number of Barrels	1
Diameter	36.0 in
Length	169.00 ft
Length (Computed Barrel)	169.01 ft
Slope (Computed)	0.009 ft/ft
Outlet Control Data	
Manning's n	0.013
Ke	0.200
Kb	0.007
Kr	0.000
Convergence Tolerance	0.00 ft
Inlet Control Data	
Equation Form	Form 1
K	0.0045
M	2.0000
C	0.0317
Y	0.6900
T1 ratio (HW/D)	1.091
T2 ratio (HW/D)	1.193
Slope Correction Factor	-0.500

Use unsubmerged inlet control 0 equation below T1 elevation.

Use submerged inlet control 0 equation above T2 elevation

In transition zone between unsubmerged and submerged inlet control, interpolate between flows at T1 & T2...

T1 Elevation	664.77 ft	T1 Flow	42.85 ft ³ /s
T2 Elevation	665.08 ft	T2 Flow	48.97 ft ³ /s

Subsection: Outlet Input Data
Label: TAM3

Return Event: 100 years
Storm Event: 100YR-24HR

Structure ID: Weir - 1	
Structure Type: Rectangular Weir	
<hr/>	
Number of Openings	1
Elevation	667.00 ft
Weir Length	188.00 ft
Weir Coefficient	3.00 (ft ^{0.5})/s

Subsection: Outlet Input Data
 Label: TAM4

Return Event: 100 years
 Storm Event: 100YR-24HR

Requested Pond Water Surface Elevations	
Minimum (Headwater)	660.00 ft
Increment (Headwater)	0.10 ft
Maximum (Headwater)	666.00 ft

Outlet Connectivity

Structure Type	Outlet ID	Direction	Outfall	E1 (ft)	E2 (ft)
Culvert-Circular	24in	Forward + Reverse	TW	660.00	666.00
Culvert-Circular	Dual 18in	Forward + Reverse	TW	664.00	666.00
Rectangular Weir	Weir - 1	Forward + Reverse	TW	665.00	666.00
Tailwater Settings	Tailwater			(N/A)	(N/A)

Subsection: Outlet Input Data
 Label: TAM4

Return Event: 100 years
 Storm Event: 100YR-24HR

Structure ID: 24in	
Structure Type: Culvert-Circular	
Number of Barrels	1
Diameter	24.0 in
Length	30.00 ft
Length (Computed Barrel)	30.02 ft
Slope (Computed)	0.033 ft/ft
Outlet Control Data	
Manning's n	0.013
Ke	0.200
Kb	0.012
Kr	0.000
Convergence Tolerance	0.00 ft
Inlet Control Data	
Equation Form	Form 1
K	0.0045
M	2.0000
C	0.0317
Y	0.6900
T1 ratio (HW/D)	1.079
T2 ratio (HW/D)	1.181
Slope Correction Factor	-0.500

Use unsubmerged inlet control 0 equation below T1 elevation.
 Use submerged inlet control 0 equation above T2 elevation

In transition zone between unsubmerged and submerged inlet control, interpolate between flows at T1 & T2...

T1 Elevation	662.16 ft	T1 Flow	15.55 ft ³ /s
T2 Elevation	662.36 ft	T2 Flow	17.77 ft ³ /s

Subsection: Outlet Input Data
 Label: TAM4

Return Event: 100 years
 Storm Event: 100YR-24HR

Structure ID: Dual 18in	
Structure Type: Culvert-Circular	
Number of Barrels	2
Diameter	18.0 in
Length	14.00 ft
Length (Computed Barrel)	14.04 ft
Slope (Computed)	0.071 ft/ft
Outlet Control Data	
Manning's n	0.013
Ke	0.200
Kb	0.018
Kr	0.000
Convergence Tolerance	0.00 ft
Inlet Control Data	
Equation Form	Form 1
K	0.0045
M	2.0000
C	0.0317
Y	0.6900
T1 ratio (HW/D)	1.060
T2 ratio (HW/D)	1.161
Slope Correction Factor	-0.500

Use unsubmerged inlet control 0 equation below T1 elevation.

Use submerged inlet control 0 equation above T2 elevation

In transition zone between unsubmerged and submerged inlet control, interpolate between flows at T1 & T2...

T1 Elevation	665.59 ft	T1 Flow	7.58 ft ³ /s
T2 Elevation	665.74 ft	T2 Flow	8.66 ft ³ /s

Subsection: Outlet Input Data
Label: TAM4

Return Event: 100 years
Storm Event: 100YR-24HR

Structure ID: Weir - 1	
Structure Type: Rectangular Weir	
<hr/>	
Number of Openings	1
Elevation	665.00 ft
Weir Length	200.00 ft
Weir Coefficient	3.00 (ft ^{0.5})/s

Subsection: Outlet Input Data
Label: TAM5

Return Event: 100 years
Storm Event: 100YR-24HR

Requested Pond Water Surface Elevations	
Minimum (Headwater)	658.00 ft
Increment (Headwater)	0.10 ft
Maximum (Headwater)	662.00 ft

Outlet Connectivity

Structure Type	Outlet ID	Direction	Outfall	E1 (ft)	E2 (ft)
Culvert-Circular	Culvert - 1	Forward + Reverse	TW	657.10	662.00
Rectangular Weir	Weir - 1	Forward + Reverse	TW	661.00	662.00
Tailwater Settings	Tailwater			(N/A)	(N/A)

Subsection: Outlet Input Data
 Label: TAM5

Return Event: 100 years
 Storm Event: 100YR-24HR

Structure ID: Culvert - 1	
Structure Type: Culvert-Circular	
Number of Barrels	1
Diameter	30.0 in
Length	52.40 ft
Length (Computed Barrel)	52.40 ft
Slope (Computed)	0.000 ft/ft
Outlet Control Data	
Manning's n	0.013
Ke	0.200
Kb	0.009
Kr	0.000
Convergence Tolerance	0.00 ft
Inlet Control Data	
Equation Form	Form 1
K	0.0045
M	2.0000
C	0.0317
Y	0.6900
T1 ratio (HW/D)	1.095
T2 ratio (HW/D)	1.197
Slope Correction Factor	-0.500

Use unsubmerged inlet control 0 equation below T1 elevation.
 Use submerged inlet control 0 equation above T2 elevation

In transition zone between unsubmerged and submerged inlet control, interpolate between flows at T1 & T2...

T1 Elevation	659.84 ft	T1 Flow	27.16 ft ³ /s
T2 Elevation	660.09 ft	T2 Flow	31.05 ft ³ /s

Subsection: Outlet Input Data
Label: TAM5

Return Event: 100 years
Storm Event: 100YR-24HR

Structure ID: Weir - 1	
Structure Type: Rectangular Weir	
<hr/>	
Number of Openings	1
Elevation	661.00 ft
Weir Length	90.00 ft
Weir Coefficient	3.00 (ft ^{0.5})/s

Subsection: Outlet Input Data
 Label: TAM6

Return Event: 100 years
 Storm Event: 100YR-24HR

Requested Pond Water Surface Elevations	
Minimum (Headwater)	654.00 ft
Increment (Headwater)	0.10 ft
Maximum (Headwater)	662.00 ft

Outlet Connectivity

Structure Type	Outlet ID	Direction	Outfall	E1 (ft)	E2 (ft)
Culvert-Box	Culvert - 1	Forward + Reverse	TW	653.73	662.00
Rectangular Weir	Weir - 1	Forward + Reverse	TW	661.00	662.00
Tailwater Settings	Tailwater			(N/A)	(N/A)

Subsection: Outlet Input Data
 Label: TAM6

Return Event: 100 years
 Storm Event: 100YR-24HR

Structure ID: Culvert - 1	
Structure Type: Culvert-Box	
Number of Barrels	1
Width	12.00 ft
Height	6.00 ft
Length	22.00 ft
Length (Computed Barrel)	22.01 ft
Slope (Computed)	0.025 ft/ft
Outlet Control Data	
Manning's n	0.013
Ke	0.500
Kb	0.002
Kr	0.000
Convergence Tolerance	0.00 ft
Inlet Control Data	
Equation Form	Form 2
K	0.5100
M	0.6670
C	0.0309
Y	0.8000
T1 ratio (HW/D)	1.176
T2 ratio (HW/D)	1.282
Slope Correction Factor	-0.500

Use unsubmerged inlet control 1 equation below T1 elevation.

Use submerged inlet control 1 equation above T2 elevation

In transition zone between unsubmerged and submerged inlet control, interpolate between flows at T1 & T2...

T1 Elevation	660.79 ft	T1 Flow	617.27 ft ³ /s
T2 Elevation	661.42 ft	T2 Flow	705.45 ft ³ /s

Subsection: Outlet Input Data
Label: TAM6

Return Event: 100 years
Storm Event: 100YR-24HR

Structure ID: Weir - 1	
Structure Type: Rectangular Weir	
<hr/>	
Number of Openings	1
Elevation	661.00 ft
Weir Length	170.00 ft
Weir Coefficient	3.00 (ft ^{0.5})/s

Subsection: Outlet Input Data
 Label: TAM7

Return Event: 100 years
 Storm Event: 100YR-24HR

Requested Pond Water Surface Elevations	
Minimum (Headwater)	650.00 ft
Increment (Headwater)	0.10 ft
Maximum (Headwater)	658.00 ft

Outlet Connectivity

Structure Type	Outlet ID	Direction	Outfall	E1 (ft)	E2 (ft)
User Defined Table	User Defined Rating Table - 1	Forward + Reverse	TW	0.00	658.00
Tailwater Settings	Tailwater			(N/A)	(N/A)

Subsection: Outlet Input Data
Label: TAM7

Return Event: 100 years
Storm Event: 100YR-24HR

Structure ID: User Defined Rating Table - 1
Structure Type: User Defined Table

Elevation (ft)	Flow (ft ³ /s)
650.00	0.00
651.45	10.00
651.68	20.00
651.86	30.00
652.02	40.00
652.17	50.00
652.31	60.00
652.44	70.00
652.56	80.00
652.68	90.00
652.80	100.00
653.07	125.00
653.33	150.00
653.57	175.00
653.81	200.00
654.03	225.00
654.25	250.00
654.46	275.00
654.66	300.00
654.86	325.00
655.05	350.00
655.24	375.00
655.43	400.00
655.61	425.00
655.80	450.00
655.99	475.00
656.18	500.00
656.37	525.00
656.55	550.00
656.73	575.00
656.91	600.00
658.00	691.00

Subsection: Outlet Input Data
 Label: West Tributary Offsite Flow

Return Event: 100 years
 Storm Event: 100YR-24HR

Requested Pond Water Surface Elevations	
Minimum (Headwater)	647.00 ft
Increment (Headwater)	0.10 ft
Maximum (Headwater)	655.00 ft

Outlet Connectivity

Structure Type	Outlet ID	Direction	Outfall	E1 (ft)	E2 (ft)
User Defined Table	User Defined Rating Table - 1	Forward	TW	0.00	655.00
Tailwater Settings	Tailwater			(N/A)	(N/A)

Subsection: Outlet Input Data
 Label: West Tributary Offsite Flow

Return Event: 100 years
 Storm Event: 100YR-24HR

Structure ID: User Defined Rating Table - 1
 Structure Type: User Defined Table

Elevation (ft)	Flow (ft ³ /s)
647.00	0.00
647.20	10.00
647.51	20.00
647.72	30.00
647.88	40.00
648.03	50.00
648.14	60.00
648.24	70.00
648.34	80.00
648.45	90.00
648.53	100.00
648.75	125.00
648.93	150.00
649.13	175.00
649.30	200.00
649.46	225.00
649.62	250.00
649.76	275.00
649.91	300.00
650.04	325.00
650.18	350.00
650.30	375.00
650.42	400.00
650.54	425.00
650.66	450.00
650.77	475.00
650.88	500.00
650.98	525.00
651.19	550.00
651.36	575.00
651.48	600.00
655.00	1,064.00

Structure ID: TW
 Structure Type: TW Setup, DS Channel

Tailwater Type: Free Outfall

Convergence Tolerances

Maximum Iterations: 30
 Tailwater Tolerance (Minimum): 0.01 ft

Subsection: Outlet Input Data
Label: West Tributary Offsite Flow

Return Event: 100 years
Storm Event: 100YR-24HR

Convergence Tolerances	
Tailwater Tolerance (Maximum)	0.50 ft
Headwater Tolerance (Minimum)	0.01 ft
Headwater Tolerance (Maximum)	0.50 ft
Flow Tolerance (Minimum)	0.001 ft ³ /s
Flow Tolerance (Maximum)	10.000 ft ³ /s

Index

0

- 001 (Unit Hydrograph Summary, 100 years)...1, 2
- 002 (Unit Hydrograph Summary, 100 years)...3, 4
- 003 (Unit Hydrograph Summary, 100 years)...5, 6
- 004 (Unit Hydrograph Summary, 100 years)...7, 8
- 005 (Unit Hydrograph Summary, 100 years)...9, 10

1

- 101 (Unit Hydrograph Summary, 100 years)...11, 12
- 102 (Unit Hydrograph Summary, 100 years)...13, 14

A

- APN2 (Unit Hydrograph Summary, 100 years)...15, 16
- APN3 (Elevation-Area Volume Curve, 100 years)...61
- APN3 (Unit Hydrograph Summary, 100 years)...17, 18
- APN3 Outlet (Outlet Input Data, 100 years)...74, 75, 76, 77
- APN4 (Elevation vs. Volume Curve, 100 years)...62
- APN4 (Unit Hydrograph Summary, 100 years)...19, 20
- APN4 Outlet (Outlet Input Data, 100 years)...78, 79, 80
- APN5 (Elevation-Area Volume Curve, 100 years)...63
- APN5 (Outlet Input Data, 100 years)...81, 82
- APN5 (Unit Hydrograph Summary, 100 years)...21, 22
- APN6 (Elevation-Area Volume Curve, 100 years)...64
- APN6 (Outlet Input Data, 100 years)...83, 84, 85
- APN6 (Unit Hydrograph Summary, 100 years)...23, 24
- ASH4 (Unit Hydrograph Summary, 100 years)...25, 26

C

- CO-3 (Channel Routing Summary, 100 years)...59
- CO-4 (Channel Routing Summary, 100 years)...60
- CREEK OUTFALL 1 (Read Hydrograph, 100 years)...27, 28, 29, 30, 31, 32
- CREEK OUTFALL 2 (Read Hydrograph, 100 years)...33, 34, 35, 36, 37, 38

D

- Depressional Storage Overflow (Outlet Input Data, 100 years)...86, 87

O

On-Site Depressional Storage (Elevation vs. Volume Curve, 100 years)...65

P

PR1 (Unit Hydrograph Summary, 100 years)...39, 40

PR2 (Unit Hydrograph Summary, 100 years)...41, 42

PR3 (Unit Hydrograph Summary, 100 years)...43, 44

T

TAM1 (Elevation vs. Volume Curve, 100 years)...66

TAM1 (Outlet Input Data, 100 years)...88, 89, 90

TAM1 (Unit Hydrograph Summary, 100 years)...45, 46

TAM2 (Elevation vs. Volume Curve, 100 years)...67

TAM2 (Outlet Input Data, 100 years)...91, 92, 93

TAM2 (Unit Hydrograph Summary, 100 years)...47, 48

TAM3 (Elevation-Area Volume Curve, 100 years)...68

TAM3 (Outlet Input Data, 100 years)...94, 95, 96

TAM3 (Unit Hydrograph Summary, 100 years)...49, 50

TAM4 (Elevation-Area Volume Curve, 100 years)...69

TAM4 (Outlet Input Data, 100 years)...97, 98, 99, 100

TAM4 (Unit Hydrograph Summary, 100 years)...51, 52

TAM5 (Elevation-Area Volume Curve, 100 years)...70

TAM5 (Outlet Input Data, 100 years)...101, 102, 103

TAM5 (Unit Hydrograph Summary, 100 years)...53, 54

TAM6 (Elevation vs. Volume Curve, 100 years)...71

TAM6 (Outlet Input Data, 100 years)...104, 105, 106

TAM6 (Unit Hydrograph Summary, 100 years)...55, 56

TAM7 (Elevation vs. Volume Curve, 100 years)...72

TAM7 (Outlet Input Data, 100 years)...107, 108

TAM7 (Unit Hydrograph Summary, 100 years)...57, 58

W

West Tributary - Clow Creek (Elevation vs. Volume Curve, 100 years)...73

West Tributary Offsite Flow (Outlet Input Data, 100 years)...109, 110, 111

Scenario Calculation Summary

Scenario Summary	
ID	7986
Label	2 Yr-24hr
Notes	
Active Topology	Base Active Topology
Hydrology	Base Hydrology
Rainfall Runoff	2Yr - 24 Hr
Physical	Base Physical
Initial Condition	Base Initial Condition
Boundary Condition	Base Boundary Condition
Infiltration and Inflow	Base Infiltration and Inflow
Output	Base Output
User Data Extensions	Base User Data Extensions
PondPack Engine Calculation Options	12Hr

Output Summary			
Output Increment	0.100 hours	Duration	48.000 hours

Rainfall Summary			
Return Event Tag	12 Hr	Rainfall Type	Time-Depth Curve
Total Depth	3.3 in	Storm Event	2YR-24HR

ICPM Output Summary			
Target Convergence	0.00 ft ³ /s	ICPM Time Step	0.100 hours
Maximum Iterations	35		

Executive Summary (Nodes)

Label	Scenario	Return Event (years)	Truncation	Hydrograph Volume (ac-ft)	Time to Peak (hours)	Peak Flow (ft ³ /s)	Maximum Water Surface Elevation (ft)	Maximum Pond Storage (ac-ft)
001	2 Yr-24hr	2	None	1.475	17.000	2.60	(N/A)	(N/A)
002	2 Yr-24hr	2	None	0.188	17.000	0.29	(N/A)	(N/A)
003	2 Yr-24hr	2	None	0.017	17.000	0.03	(N/A)	(N/A)
004	2 Yr-24hr	2	None	0.091	16.100	0.14	(N/A)	(N/A)
005	2 Yr-24hr	2	None	0.037	17.000	0.07	(N/A)	(N/A)
101	2 Yr-24hr	2	None	0.191	17.000	0.36	(N/A)	(N/A)
102	2 Yr-24hr	2	None	0.008	17.000	0.01	(N/A)	(N/A)
APN2	2 Yr-24hr	2	None	0.938	17.000	1.60	(N/A)	(N/A)
APN3	2 Yr-24hr	2	None	7.614	16.100	11.17	(N/A)	(N/A)
APN3 (IN)	2 Yr-24hr	2	None	7.614	16.100	11.17	(N/A)	(N/A)
APN3 (OUT)	2 Yr-24hr	2	None	7.529	18.500	7.56	681.44	2.615
APN4 (IN)	2 Yr-24hr	2	None	2.327	16.200	3.54	(N/A)	(N/A)
APN4 (OUT)	2 Yr-24hr	2	None	2.274	17.500	2.90	681.38	0.716
APN4	2 Yr-24hr	2	None	2.327	16.200	3.54	(N/A)	(N/A)

Scenario Calculation Summary

Executive Summary (Nodes)

Label	Scenario	Return Event (years)	Truncation	Hydrograph Volume (ac-ft)	Time to Peak (hours)	Peak Flow (ft ³ /s)	Maximum Water Surface Elevation (ft)	Maximum Pond Storage (ac-ft)
APN5 (IN)	2 Yr-24hr	2	None	7.634	17.100	10.97	(N/A)	(N/A)
APN5 (OUT)	2 Yr-24hr	2	None	7.535	20.800	4.57	678.89	3.503
APN5	2 Yr-24hr	2	None	5.360	16.200	8.16	(N/A)	(N/A)
APN6 (IN)	2 Yr-24hr	2	None	13.921	17.100	14.61	(N/A)	(N/A)
APN6 (OUT)	2 Yr-24hr	2	None	11.253	24.500	5.48	668.88	6.826
APN6	2 Yr-24hr	2	None	6.387	17.100	10.58	(N/A)	(N/A)
ASH4	2 Yr-24hr	2	None	0.608	16.000	0.93	(N/A)	(N/A)
CLOW CREEK OUTFALL OFF-SITE	2 Yr-24hr	2	None	311.383	17.100	204.04	(N/A)	(N/A)
CREEK OUTFALL 1	2 Yr-24hr	2	None	96.028	12.200	82.38	(N/A)	(N/A)
CREEK OUTFALL 2	2 Yr-24hr	2	None	152.418	0.100	168.35	(N/A)	(N/A)
J-5	2 Yr-24hr	2	None	255.362	7.800	219.77	(N/A)	(N/A)
J-6	2 Yr-24hr	2	None	5.587	16.000	8.47	(N/A)	(N/A)
Offsite Flow (East)	2 Yr-24hr	2	None	0.037	17.000	0.07	(N/A)	(N/A)
Offsite Flow (South)	2 Yr-24hr	2	None	0.091	16.100	0.14	(N/A)	(N/A)
Offsite Flow (West)	2 Yr-24hr	2	None	0.017	17.000	0.03	(N/A)	(N/A)
On-Site Depressional Storage (IN)	2 Yr-24hr	2	None	0.188	17.000	0.29	(N/A)	(N/A)
On-Site Depressional Storage (OUT)	2 Yr-24hr	2	None	0.000	0.000	0.00	651.10	0.188
PR1	2 Yr-24hr	2	None	2.783	16.000	4.21	(N/A)	(N/A)
PR2	2 Yr-24hr	2	None	1.372	16.000	2.08	(N/A)	(N/A)
PR3	2 Yr-24hr	2	None	0.824	16.000	1.25	(N/A)	(N/A)
TAM1 (IN)	2 Yr-24hr	2	None	280.879	7.900	221.07	(N/A)	(N/A)
TAM1 (OUT)	2 Yr-24hr	2	None	280.420	9.000	205.42	663.13	17.596
TAM1	2 Yr-24hr	2	None	17.988	16.100	27.70	(N/A)	(N/A)
TAM2 (IN)	2 Yr-24hr	2	None	12.265	24.000	5.72	(N/A)	(N/A)
TAM2 (OUT)	2 Yr-24hr	2	None	11.766	24.100	5.64	663.46	0.793
TAM2	2 Yr-24hr	2	None	1.012	16.000	1.51	(N/A)	(N/A)
TAM3 (IN)	2 Yr-24hr	2	None	13.235	18.100	6.09	(N/A)	(N/A)

Scenario Calculation Summary

Executive Summary (Nodes)

Label	Scenario	Return Event (years)	Truncation	Hydrograph Volume (ac-ft)	Time to Peak (hours)	Peak Flow (ft ³ /s)	Maximum Water Surface Elevation (ft)	Maximum Pond Storage (ac-ft)
TAM3 (OUT)	2 Yr-24hr	2	None	12.847	24.200	5.91	662.59	0.908
TAM3	2 Yr-24hr	2	None	1.469	16.000	2.20	(N/A)	(N/A)
TAM4 (IN)	2 Yr-24hr	2	None	21.431	17.100	16.62	(N/A)	(N/A)
TAM4 (OUT)	2 Yr-24hr	2	None	19.232	19.400	12.52	661.93	4.659
TAM4	2 Yr-24hr	2	None	8.584	16.200	12.79	(N/A)	(N/A)
TAM5 (IN)	2 Yr-24hr	2	None	20.715	19.100	13.70	(N/A)	(N/A)
TAM5 (OUT)	2 Yr-24hr	2	None	19.924	22.200	11.26	658.83	2.863
TAM5	2 Yr-24hr	2	None	1.484	16.100	2.12	(N/A)	(N/A)
TAM6 (IN)	2 Yr-24hr	2	None	282.823	9.000	205.46	(N/A)	(N/A)
TAM6 (OUT)	2 Yr-24hr	2	None	282.622	9.500	203.98	657.37	3.532
TAM6	2 Yr-24hr	2	None	2.403	17.000	4.07	(N/A)	(N/A)
TAM7 (IN)	2 Yr-24hr	2	None	311.730	9.500	205.42	(N/A)	(N/A)
TAM7 (OUT)	2 Yr-24hr	2	None	309.732	10.100	203.65	653.84	10.660
TAM7	2 Yr-24hr	2	None	9.183	17.100	14.18	(N/A)	(N/A)
West Tributary - Clow Creek (IN)	2 Yr-24hr	2	None	311.406	17.100	204.06	(N/A)	(N/A)
West Tributary - Clow Creek (OUT)	2 Yr-24hr	2	None	311.383	17.100	204.04	649.33	0.079

Executive Summary (Links)

Label	Type	Location	Hydrograph Volume (ac-ft)	Peak Time (hours)	Peak Flow (ft ³ /s)	End Point	Node Flow Direction
APN3 Outlet	Pond Outlet	Upstream	7.614	16.100	11.17	APN3	Pond Inflow
APN3 Outlet	Pond Outlet	Outflow	7.529	18.500	7.56	APN3	Pond Outflow
APN3 Outlet	Pond Outlet	Link	7.529	18.500	7.56		
APN3 Outlet	Pond Outlet	Downstream	280.879	7.900	221.07	TAM1	
APN4 Outlet	Pond Outlet	Upstream	2.327	16.200	3.54	APN4	Pond Inflow
APN4 Outlet	Pond Outlet	Outflow	2.274	17.500	2.90	APN4	Pond Outflow
APN4 Outlet	Pond Outlet	Link	2.274	17.500	2.90		
APN4 Outlet	Pond Outlet	Downstream	7.634	17.100	10.97	APN5	
APN5 Outlet	Pond Outlet	Upstream	7.634	17.100	10.97	APN5	Pond Inflow
APN5 Outlet	Pond Outlet	Outflow	7.535	20.800	4.57	APN5	Pond Outflow

Scenario Calculation Summary

Executive Summary (Links)

Label	Type	Location	Hydrograph Volume (ac-ft)	Peak Time (hours)	Peak Flow (ft ³ /s)	End Point	Node Flow Direction
APN5 Outlet	Pond Outlet	Link	7.534	20.800	4.57		
APN5 Outlet	Pond Outlet	Downstream	13.921	17.100	14.61	APN6	
APN6 Outlet	Pond Outlet	Upstream	13.921	17.100	14.61	APN6	Pond Inflow
APN6 Outlet	Pond Outlet	Outflow	11.253	24.500	5.48	APN6	Pond Outflow
APN6 Outlet	Pond Outlet	Link	11.236	24.500	5.48		
APN6 Outlet	Pond Outlet	Downstream	12.265	24.000	5.72	TAM2	
CO-3	Channel	Upstream	255.362	7.800	219.77	J-5	
CO-3	Channel	Link	255.362	7.900	219.77		
CO-3	Channel	Downstream	280.879	7.900	221.07	TAM1	
CO-4	Channel	Upstream	5.587	16.000	8.47	J-6	
CO-4	Channel	Link	5.587	16.100	8.47		
CO-4	Channel	Downstream	255.362	7.800	219.77	J-5	
OFFSITE FLOW	Pond Outlet	Upstream	311.406	17.100	204.06	West Tributary - Clow Creek	Pond Inflow
OFFSITE FLOW	Pond Outlet	Outflow	311.383	17.100	204.04	West Tributary - Clow Creek	Pond Outflow
OFFSITE FLOW	Pond Outlet	Link	311.383	17.100	204.04		
OFFSITE FLOW	Pond Outlet	Downstream	311.383	17.100	204.04	CLOW CREEK OUTFALL OFF-SITE	
OVERFLOW TO CREEK	Pond Outlet	Upstream	0.188	17.000	0.29	On-Site Depressional Storage	Pond Inflow
OVERFLOW TO CREEK	Pond Outlet	Outflow	0.000	0.000	0.00	On-Site Depressional Storage	Pond Outflow
OVERFLOW TO CREEK	Pond Outlet	Link	0.000	0.000	0.00		
OVERFLOW TO CREEK	Pond Outlet	Downstream	311.406	17.100	204.06	West Tributary - Clow Creek	
TAM1 OUTLET	Pond Outlet	Upstream	280.879	7.900	221.07	TAM1	Pond Inflow
TAM1 OUTLET	Pond Outlet	Outflow	280.420	9.000	205.42	TAM1	Pond Outflow
TAM1 OUTLET	Pond Outlet	Link	280.417	9.000	205.42		
TAM1 OUTLET	Pond Outlet	Downstream	282.823	9.000	205.46	TAM6	
TAM2 Outlet	Pond Outlet	Upstream	12.265	24.000	5.72	TAM2	Pond Inflow
TAM2 Outlet	Pond Outlet	Outflow	11.766	24.100	5.64	TAM2	Pond Outflow
TAM2 Outlet	Pond Outlet	Link	11.766	24.100	5.64		
TAM2 Outlet	Pond Outlet	Downstream	13.235	18.100	6.09	TAM3	

Scenario Calculation Summary

Executive Summary (Links)

Label	Type	Location	Hydrograph Volume (ac-ft)	Peak Time (hours)	Peak Flow (ft ³ /s)	End Point	Node Flow Direction
TAM3 Outlet	Pond Outlet	Upstream	13.235	18.100	6.09	TAM3	Pond Inflow
TAM3 Outlet	Pond Outlet	Outflow	12.847	24.200	5.91	TAM3	Pond Outflow
TAM3 Outlet	Pond Outlet	Link	12.826	24.200	5.91		
TAM3 Outlet	Pond Outlet	Downstream	21.431	17.100	16.62	TAM4	
TAM4 Outlet	Pond Outlet	Upstream	21.431	17.100	16.62	TAM4	Pond Inflow
TAM4 Outlet	Pond Outlet	Outflow	19.232	19.400	12.52	TAM4	Pond Outflow
TAM4 Outlet	Pond Outlet	Link	19.232	19.400	12.52		
TAM4 Outlet	Pond Outlet	Downstream	20.715	19.100	13.70	TAM5	
TAM5 Outlet	Pond Outlet	Upstream	20.715	19.100	13.70	TAM5	Pond Inflow
TAM5 Outlet	Pond Outlet	Outflow	19.924	22.200	11.26	TAM5	Pond Outflow
TAM5 Outlet	Pond Outlet	Link	19.924	22.200	11.26		
TAM5 Outlet	Pond Outlet	Downstream	311.730	9.500	205.42	TAM7	
TAM6	Pond Outlet	Upstream	282.823	9.000	205.46	TAM6	Pond Inflow
TAM6	Pond Outlet	Outflow	282.622	9.500	203.98	TAM6	Pond Outflow
TAM6	Pond Outlet	Link	282.620	9.500	203.98		
TAM6	Pond Outlet	Downstream	311.730	9.500	205.42	TAM7	
TAM7 Outlet	Pond Outlet	Upstream	311.730	9.500	205.42	TAM7	Pond Inflow
TAM7 Outlet	Pond Outlet	Outflow	309.732	10.100	203.65	TAM7	Pond Outflow
TAM7 Outlet	Pond Outlet	Link	309.688	10.100	203.65		
TAM7 Outlet	Pond Outlet	Downstream	311.406	17.100	204.06	West Tributary - Clow Creek	

Messages

Message Id	29
Scenario	2 Yr-24hr
Element Type	Catchment
Element Id	7688
Label	001
Time	(N/A)
Message	Tm > .25Tp. Computation increment, Tm, is greater than 1/4 Time to Peak on Unit Hydrograph. Using a larger Tc can solve this problem.
Source	Warning

Scenario Calculation Summary

Messages

Message Id	67
Scenario	2 Yr-24hr
Element Type	Composite Outlet Structure
Element Id	7699
Label	West Tributary Offsite Flow
Time	(N/A)
Message	Flow direction set to reverse for one ore more structures in composite outlet structure West Tributary Offsite Flow. To eliminate this warning, edit outlet data and select forward only. If reverse flow analysis is required, then the tailwater conditions must be set to interconnected pond.
Source	Warning

Message Id	67
Scenario	2 Yr-18hr
Element Type	Composite Outlet Structure
Element Id	7699
Label	West Tributary Offsite Flow
Time	(N/A)
Message	Flow direction set to reverse for one ore more structures in composite outlet structure West Tributary Offsite Flow. To eliminate this warning, edit outlet data and select forward only. If reverse flow analysis is required, then the tailwater conditions must be set to interconnected pond.
Source	Warning

Message Id	67
Scenario	2 Yr-12hr
Element Type	Composite Outlet Structure
Element Id	7699
Label	West Tributary Offsite Flow
Time	(N/A)
Message	Flow direction set to reverse for one ore more structures in composite outlet structure West Tributary Offsite Flow. To eliminate this warning, edit outlet data and select forward only. If reverse flow analysis is required, then the tailwater conditions must be set to interconnected pond.
Source	Warning

Message Id	67
Scenario	2 Yr-6hr
Element Type	Composite Outlet Structure
Element Id	7699
Label	West Tributary Offsite Flow
Time	(N/A)
Message	Flow direction set to reverse for one ore more structures in composite outlet structure West Tributary Offsite Flow. To eliminate this warning, edit outlet data and select forward only. If reverse flow analysis is required, then the tailwater conditions must be set to interconnected pond.
Source	Warning

Scenario Calculation Summary

Messages

Message Id	67
Scenario	2 Yr-3hr
Element Type	Composite Outlet Structure
Element Id	7699
Label	West Tributary Offsite Flow
Time	(N/A)
Message	Flow direction set to reverse for one ore more structures in composite outlet structure West Tributary Offsite Flow. To eliminate this warning, edit outlet data and select forward only. If reverse flow analysis is required, then the tailwater conditions must be set to interconnected pond.
Source	Warning

Message Id	67
Scenario	2 Yr-2hr
Element Type	Composite Outlet Structure
Element Id	7699
Label	West Tributary Offsite Flow
Time	(N/A)
Message	Flow direction set to reverse for one ore more structures in composite outlet structure West Tributary Offsite Flow. To eliminate this warning, edit outlet data and select forward only. If reverse flow analysis is required, then the tailwater conditions must be set to interconnected pond.
Source	Warning

Message Id	67
Scenario	2 Yr-1hr
Element Type	Composite Outlet Structure
Element Id	7699
Label	West Tributary Offsite Flow
Time	(N/A)
Message	Flow direction set to reverse for one ore more structures in composite outlet structure West Tributary Offsite Flow. To eliminate this warning, edit outlet data and select forward only. If reverse flow analysis is required, then the tailwater conditions must be set to interconnected pond.
Source	Warning

Message Id	39
Scenario	2 Yr-24hr
Element Type	Composite Outlet Structure
Element Id	7697
Label	Depressional Storage Overflow
Time	(N/A)
Message	Reverse flow conditions encountered for one or more headwater elevations. Calculated reverse flows may be approximate.
Source	Warning

Scenario Calculation Summary

Messages

Message Id	39
Scenario	2 Yr-18hr
Element Type	Composite Outlet Structure
Element Id	7697
Label	Depressional Storage Overflow
Time	(N/A)
Message	Reverse flow conditions encountered for one or more headwater elevations. Calculated reverse flows may be approximate.
Source	Warning

Message Id	39
Scenario	2 Yr-12hr
Element Type	Composite Outlet Structure
Element Id	7697
Label	Depressional Storage Overflow
Time	(N/A)
Message	Reverse flow conditions encountered for one or more headwater elevations. Calculated reverse flows may be approximate.
Source	Warning

Message Id	39
Scenario	2 Yr-6hr
Element Type	Composite Outlet Structure
Element Id	7697
Label	Depressional Storage Overflow
Time	(N/A)
Message	Reverse flow conditions encountered for one or more headwater elevations. Calculated reverse flows may be approximate.
Source	Warning

Message Id	39
Scenario	2 Yr-3hr
Element Type	Composite Outlet Structure
Element Id	7697
Label	Depressional Storage Overflow
Time	(N/A)
Message	Reverse flow conditions encountered for one or more headwater elevations. Calculated reverse flows may be approximate.
Source	Warning

Message Id	39
Scenario	2 Yr-2hr
Element Type	Composite Outlet Structure
Element Id	7697
Label	Depressional Storage Overflow
Time	(N/A)
Message	Reverse flow conditions encountered for one or more headwater elevations. Calculated reverse flows may be approximate.
Source	Warning

Scenario Calculation Summary

Messages

Message Id	39
Scenario	2 Yr-1hr
Element Type	Composite Outlet Structure
Element Id	7697
Label	Depressional Storage Overflow
Time	(N/A)
Message	Reverse flow conditions encountered for one or more headwater elevations. Calculated reverse flows may be approximate.
Source	Warning

Message Id	-1
Scenario	2 Yr-24hr
Element Type	Composite Outlet Structure
Element Id	5390
Label	TAM7
Time	(N/A)
Message	A user defined rating table is being used with a non-free outfall tailwater setting. For user defined rating tables it is suggested to use only free outfall tailwater as tailwater effects are not handled.
Source	Precalculation

Scenario Calculation Summary

Scenario Summary	
ID	7987
Label	2 Yr-18hr
Notes	
Active Topology	<I> Base Active Topology
Hydrology	<I> Base Hydrology
Rainfall Runoff	2Yr - 18 Hr
Physical	<I> Base Physical
Initial Condition	<I> Base Initial Condition
Boundary Condition	<I> Base Boundary Condition
Infiltration and Inflow	<I> Base Infiltration and Inflow
Output	<I> Base Output
User Data Extensions	<I> Base User Data Extensions
PondPack Engine Calculation Options	<I> 12Hr

Output Summary			
Output Increment	0.100 hours	Duration	48.000 hours

Rainfall Summary			
Return Event Tag	12 Hr	Rainfall Type	Time-Depth Curve
Total Depth	3.1 in	Storm Event	2YR-18HR

ICPM Output Summary			
Target Convergence	0.00 ft ³ /s	ICPM Time Step	0.100 hours
Maximum Iterations	35		

Executive Summary (Nodes)

Label	Scenario	Return Event (years)	Truncation	Hydrograph Volume (ac-ft)	Time to Peak (hours)	Peak Flow (ft ³ /s)	Maximum Water Surface Elevation (ft)	Maximum Pond Storage (ac-ft)
001	2 Yr-18hr	2	None	1.289	12.800	3.03	(N/A)	(N/A)
002	2 Yr-18hr	2	None	0.168	12.100	0.35	(N/A)	(N/A)
003	2 Yr-18hr	2	None	0.015	12.700	0.04	(N/A)	(N/A)
004	2 Yr-18hr	2	None	0.081	12.100	0.17	(N/A)	(N/A)
005	2 Yr-18hr	2	None	0.032	12.700	0.08	(N/A)	(N/A)
101	2 Yr-18hr	2	None	0.165	12.700	0.41	(N/A)	(N/A)
102	2 Yr-18hr	2	None	0.007	12.700	0.02	(N/A)	(N/A)
APN2	2 Yr-18hr	2	None	0.827	12.700	1.88	(N/A)	(N/A)
APN3	2 Yr-18hr	2	None	6.911	12.100	13.60	(N/A)	(N/A)
APN3 (IN)	2 Yr-18hr	2	None	6.911	12.100	13.60	(N/A)	(N/A)
APN3 (OUT)	2 Yr-18hr	2	None	6.842	14.400	8.09	681.49	2.844
APN4 (IN)	2 Yr-18hr	2	None	2.096	12.200	4.28	(N/A)	(N/A)
APN4 (OUT)	2 Yr-18hr	2	None	2.053	13.000	3.08	681.49	0.784
APN4	2 Yr-18hr	2	None	2.096	12.200	4.28	(N/A)	(N/A)

Scenario Calculation Summary

Executive Summary (Nodes)

Label	Scenario	Return Event (years)	Truncation	Hydrograph Volume (ac-ft)	Time to Peak (hours)	Peak Flow (ft ³ /s)	Maximum Water Surface Elevation (ft)	Maximum Pond Storage (ac-ft)
APN5 (IN)	2 Yr-18hr	2	None	6.879	12.800	12.79	(N/A)	(N/A)
APN5 (OUT)	2 Yr-18hr	2	None	6.798	16.600	4.56	678.88	3.488
APN5	2 Yr-18hr	2	None	4.825	12.200	9.84	(N/A)	(N/A)
APN6 (IN)	2 Yr-18hr	2	None	12.443	12.900	16.42	(N/A)	(N/A)
APN6 (OUT)	2 Yr-18hr	2	None	10.612	18.800	4.96	668.80	6.262
APN6	2 Yr-18hr	2	None	5.645	12.900	12.48	(N/A)	(N/A)
ASH4	2 Yr-18hr	2	None	0.548	12.000	1.13	(N/A)	(N/A)
CLOW CREEK OUTFALL OFF-SITE	2 Yr-18hr	2	None	306.225	13.000	252.51	(N/A)	(N/A)
CREEK OUTFALL 1	2 Yr-18hr	2	None	96.028	12.200	82.38	(N/A)	(N/A)
CREEK OUTFALL 2	2 Yr-18hr	2	None	152.418	0.100	168.35	(N/A)	(N/A)
J-5	2 Yr-18hr	2	None	254.711	7.800	221.38	(N/A)	(N/A)
J-6	2 Yr-18hr	2	None	5.047	12.000	10.29	(N/A)	(N/A)
Offsite Flow (East)	2 Yr-18hr	2	None	0.032	12.700	0.08	(N/A)	(N/A)
Offsite Flow (South)	2 Yr-18hr	2	None	0.081	12.100	0.17	(N/A)	(N/A)
Offsite Flow (West)	2 Yr-18hr	2	None	0.015	12.700	0.04	(N/A)	(N/A)
On-Site Depressional Storage (IN)	2 Yr-18hr	2	None	0.168	12.100	0.35	(N/A)	(N/A)
On-Site Depressional Storage (OUT)	2 Yr-18hr	2	None	0.000	0.000	0.00	651.09	0.168
PR1	2 Yr-18hr	2	None	2.515	12.000	5.12	(N/A)	(N/A)
PR2	2 Yr-18hr	2	None	1.239	12.000	2.52	(N/A)	(N/A)
PR3	2 Yr-18hr	2	None	0.744	12.000	1.52	(N/A)	(N/A)
TAM1 (IN)	2 Yr-18hr	2	None	277.718	12.100	229.00	(N/A)	(N/A)
TAM1 (OUT)	2 Yr-18hr	2	None	277.293	12.400	224.55	663.35	18.759
TAM1	2 Yr-18hr	2	None	16.165	12.200	33.36	(N/A)	(N/A)
TAM2 (IN)	2 Yr-18hr	2	None	11.530	18.000	5.23	(N/A)	(N/A)
TAM2 (OUT)	2 Yr-18hr	2	None	11.102	18.200	5.08	663.40	0.751
TAM2	2 Yr-18hr	2	None	0.918	12.000	1.84	(N/A)	(N/A)
TAM3 (IN)	2 Yr-18hr	2	None	12.431	13.600	5.92	(N/A)	(N/A)

Scenario Calculation Summary

Executive Summary (Nodes)

Label	Scenario	Return Event (years)	Truncation	Hydrograph Volume (ac-ft)	Time to Peak (hours)	Peak Flow (ft ³ /s)	Maximum Water Surface Elevation (ft)	Maximum Pond Storage (ac-ft)
TAM3 (OUT)	2 Yr-18hr	2	None	12.185	18.200	5.36	662.53	0.830
TAM3	2 Yr-18hr	2	None	1.329	12.100	2.68	(N/A)	(N/A)
TAM4 (IN)	2 Yr-18hr	2	None	19.943	12.900	18.82	(N/A)	(N/A)
TAM4 (OUT)	2 Yr-18hr	2	None	18.040	15.000	12.54	661.93	4.664
TAM4	2 Yr-18hr	2	None	7.758	12.300	15.48	(N/A)	(N/A)
TAM5 (IN)	2 Yr-18hr	2	None	19.394	14.400	13.80	(N/A)	(N/A)
TAM5 (OUT)	2 Yr-18hr	2	None	18.925	18.100	10.77	658.78	2.744
TAM5	2 Yr-18hr	2	None	1.354	12.100	2.60	(N/A)	(N/A)
TAM6 (IN)	2 Yr-18hr	2	None	279.414	12.400	229.21	(N/A)	(N/A)
TAM6 (OUT)	2 Yr-18hr	2	None	279.215	12.600	228.67	657.66	4.041
TAM6	2 Yr-18hr	2	None	2.121	12.800	4.79	(N/A)	(N/A)
TAM7 (IN)	2 Yr-18hr	2	None	306.376	12.700	250.53	(N/A)	(N/A)
TAM7 (OUT)	2 Yr-18hr	2	None	304.783	13.000	249.26	654.24	12.016
TAM7	2 Yr-18hr	2	None	8.235	12.800	17.04	(N/A)	(N/A)
West Tributary - Clow Creek (IN)	2 Yr-18hr	2	None	306.243	12.900	252.52	(N/A)	(N/A)
West Tributary - Clow Creek (OUT)	2 Yr-18hr	2	None	306.225	13.000	252.51	649.63	0.120

Executive Summary (Links)

Label	Type	Location	Hydrograph Volume (ac-ft)	Peak Time (hours)	Peak Flow (ft ³ /s)	End Point	Node Flow Direction
APN3 Outlet	Pond Outlet	Upstream	6.911	12.100	13.60	APN3	Pond Inflow
APN3 Outlet	Pond Outlet	Outflow	6.842	14.400	8.09	APN3	Pond Outflow
APN3 Outlet	Pond Outlet	Link	6.842	14.400	8.09		
APN3 Outlet	Pond Outlet	Downstream	277.718	12.100	229.00	TAM1	
APN4 Outlet	Pond Outlet	Upstream	2.096	12.200	4.28	APN4	Pond Inflow
APN4 Outlet	Pond Outlet	Outflow	2.053	13.000	3.08	APN4	Pond Outflow
APN4 Outlet	Pond Outlet	Link	2.053	13.000	3.08		
APN4 Outlet	Pond Outlet	Downstream	6.879	12.800	12.79	APN5	
APN5 Outlet	Pond Outlet	Upstream	6.879	12.800	12.79	APN5	Pond Inflow
APN5 Outlet	Pond Outlet	Outflow	6.798	16.600	4.56	APN5	Pond Outflow

Scenario Calculation Summary

Executive Summary (Links)

Label	Type	Location	Hydrograph Volume (ac-ft)	Peak Time (hours)	Peak Flow (ft ³ /s)	End Point	Node Flow Direction
APN5 Outlet	Pond Outlet	Link	6.798	16.600	4.56		
APN5 Outlet	Pond Outlet	Downstream	12.443	12.900	16.42	APN6	
APN6 Outlet	Pond Outlet	Upstream	12.443	12.900	16.42	APN6	Pond Inflow
APN6 Outlet	Pond Outlet	Outflow	10.612	18.800	4.96	APN6	Pond Outflow
APN6 Outlet	Pond Outlet	Link	10.599	18.800	4.96		
APN6 Outlet	Pond Outlet	Downstream	11.530	18.000	5.23	TAM2	
CO-3	Channel	Upstream	254.711	7.800	221.38	J-5	
CO-3	Channel	Link	254.711	7.900	221.38		
CO-3	Channel	Downstream	277.718	12.100	229.00	TAM1	
CO-4	Channel	Upstream	5.047	12.000	10.29	J-6	
CO-4	Channel	Link	5.047	12.100	10.29		
CO-4	Channel	Downstream	254.711	7.800	221.38	J-5	
OFFSITE FLOW	Pond Outlet	Upstream	306.243	12.900	252.52	West Tributary - Clow Creek	Pond Inflow
OFFSITE FLOW	Pond Outlet	Outflow	306.225	13.000	252.51	West Tributary - Clow Creek	Pond Outflow
OFFSITE FLOW	Pond Outlet	Link	306.225	13.000	252.51		
OFFSITE FLOW	Pond Outlet	Downstream	306.225	13.000	252.51	CLOW CREEK OUTFALL OFF-SITE	
OVERFLOW TO CREEK	Pond Outlet	Upstream	0.168	12.100	0.35	On-Site Depressional Storage	Pond Inflow
OVERFLOW TO CREEK	Pond Outlet	Outflow	0.000	0.000	0.00	On-Site Depressional Storage	Pond Outflow
OVERFLOW TO CREEK	Pond Outlet	Link	0.000	0.000	0.00		
OVERFLOW TO CREEK	Pond Outlet	Downstream	306.243	12.900	252.52	West Tributary - Clow Creek	
TAM1 OUTLET	Pond Outlet	Upstream	277.718	12.100	229.00	TAM1	Pond Inflow
TAM1 OUTLET	Pond Outlet	Outflow	277.293	12.400	224.55	TAM1	Pond Outflow
TAM1 OUTLET	Pond Outlet	Link	277.291	12.400	224.55		
TAM1 OUTLET	Pond Outlet	Downstream	279.414	12.400	229.21	TAM6	
TAM2 Outlet	Pond Outlet	Upstream	11.530	18.000	5.23	TAM2	Pond Inflow
TAM2 Outlet	Pond Outlet	Outflow	11.102	18.200	5.08	TAM2	Pond Outflow
TAM2 Outlet	Pond Outlet	Link	11.088	18.200	5.08		
TAM2 Outlet	Pond Outlet	Downstream	12.431	13.600	5.92	TAM3	

Scenario Calculation Summary

Executive Summary (Links)

Label	Type	Location	Hydrograph Volume (ac-ft)	Peak Time (hours)	Peak Flow (ft ³ /s)	End Point	Node Flow Direction
TAM3 Outlet	Pond Outlet	Upstream	12.431	13.600	5.92	TAM3	Pond Inflow
TAM3 Outlet	Pond Outlet	Outflow	12.185	18.200	5.36	TAM3	Pond Outflow
TAM3 Outlet	Pond Outlet	Link	12.185	18.200	5.36		
TAM3 Outlet	Pond Outlet	Downstream	19.943	12.900	18.82	TAM4	
TAM4 Outlet	Pond Outlet	Upstream	19.943	12.900	18.82	TAM4	Pond Inflow
TAM4 Outlet	Pond Outlet	Outflow	18.040	15.000	12.54	TAM4	Pond Outflow
TAM4 Outlet	Pond Outlet	Link	18.020	15.000	12.54		
TAM4 Outlet	Pond Outlet	Downstream	19.394	14.400	13.80	TAM5	
TAM5 Outlet	Pond Outlet	Upstream	19.394	14.400	13.80	TAM5	Pond Inflow
TAM5 Outlet	Pond Outlet	Outflow	18.925	18.100	10.77	TAM5	Pond Outflow
TAM5 Outlet	Pond Outlet	Link	18.902	18.100	10.77		
TAM5 Outlet	Pond Outlet	Downstream	306.376	12.700	250.53	TAM7	
TAM6	Pond Outlet	Upstream	279.414	12.400	229.21	TAM6	Pond Inflow
TAM6	Pond Outlet	Outflow	279.215	12.600	228.67	TAM6	Pond Outflow
TAM6	Pond Outlet	Link	279.213	12.600	228.67		
TAM6	Pond Outlet	Downstream	306.376	12.700	250.53	TAM7	
TAM7 Outlet	Pond Outlet	Upstream	306.376	12.700	250.53	TAM7	Pond Inflow
TAM7 Outlet	Pond Outlet	Outflow	304.783	13.000	249.26	TAM7	Pond Outflow
TAM7 Outlet	Pond Outlet	Link	304.748	13.000	249.26		
TAM7 Outlet	Pond Outlet	Downstream	306.243	12.900	252.52	West Tributary - Clow Creek	

Messages

Message Id	29
Scenario	2 Yr-24hr
Element Type	Catchment
Element Id	7688
Label	001
Time	(N/A)
Message	Tm > .25Tp. Computation increment, Tm, is greater than 1/4 Time to Peak on Unit Hydrograph. Using a larger Tc can solve this problem.
Source	Warning

Scenario Calculation Summary

Messages

Message Id	67
Scenario	2 Yr-24hr
Element Type	Composite Outlet Structure
Element Id	7699
Label	West Tributary Offsite Flow
Time	(N/A)
Message	Flow direction set to reverse for one ore more structures in composite outlet structure West Tributary Offsite Flow. To eliminate this warning, edit outlet data and select forward only. If reverse flow analysis is required, then the tailwater conditions must be set to interconnected pond.
Source	Warning
Message Id	67
Scenario	2 Yr-18hr
Element Type	Composite Outlet Structure
Element Id	7699
Label	West Tributary Offsite Flow
Time	(N/A)
Message	Flow direction set to reverse for one ore more structures in composite outlet structure West Tributary Offsite Flow. To eliminate this warning, edit outlet data and select forward only. If reverse flow analysis is required, then the tailwater conditions must be set to interconnected pond.
Source	Warning
Message Id	67
Scenario	2 Yr-12hr
Element Type	Composite Outlet Structure
Element Id	7699
Label	West Tributary Offsite Flow
Time	(N/A)
Message	Flow direction set to reverse for one ore more structures in composite outlet structure West Tributary Offsite Flow. To eliminate this warning, edit outlet data and select forward only. If reverse flow analysis is required, then the tailwater conditions must be set to interconnected pond.
Source	Warning
Message Id	67
Scenario	2 Yr-6hr
Element Type	Composite Outlet Structure
Element Id	7699
Label	West Tributary Offsite Flow
Time	(N/A)
Message	Flow direction set to reverse for one ore more structures in composite outlet structure West Tributary Offsite Flow. To eliminate this warning, edit outlet data and select forward only. If reverse flow analysis is required, then the tailwater conditions must be set to interconnected pond.
Source	Warning

Scenario Calculation Summary

Messages

Message Id	67
Scenario	2 Yr-3hr
Element Type	Composite Outlet Structure
Element Id	7699
Label	West Tributary Offsite Flow
Time	(N/A)
Message	Flow direction set to reverse for one ore more structures in composite outlet structure West Tributary Offsite Flow. To eliminate this warning, edit outlet data and select forward only. If reverse flow analysis is required, then the tailwater conditions must be set to interconnected pond.
Source	Warning
Message Id	67
Scenario	2 Yr-2hr
Element Type	Composite Outlet Structure
Element Id	7699
Label	West Tributary Offsite Flow
Time	(N/A)
Message	Flow direction set to reverse for one ore more structures in composite outlet structure West Tributary Offsite Flow. To eliminate this warning, edit outlet data and select forward only. If reverse flow analysis is required, then the tailwater conditions must be set to interconnected pond.
Source	Warning
Message Id	67
Scenario	2 Yr-1hr
Element Type	Composite Outlet Structure
Element Id	7699
Label	West Tributary Offsite Flow
Time	(N/A)
Message	Flow direction set to reverse for one ore more structures in composite outlet structure West Tributary Offsite Flow. To eliminate this warning, edit outlet data and select forward only. If reverse flow analysis is required, then the tailwater conditions must be set to interconnected pond.
Source	Warning
Message Id	39
Scenario	2 Yr-24hr
Element Type	Composite Outlet Structure
Element Id	7697
Label	Depressional Storage Overflow
Time	(N/A)
Message	Reverse flow conditions encountered for one or more headwater elevations. Calculated reverse flows may be approximate.
Source	Warning

Scenario Calculation Summary

Messages

Message Id	39
Scenario	2 Yr-18hr
Element Type	Composite Outlet Structure
Element Id	7697
Label	Depressional Storage Overflow
Time	(N/A)
Message	Reverse flow conditions encountered for one or more headwater elevations. Calculated reverse flows may be approximate.
Source	Warning

Message Id	39
Scenario	2 Yr-12hr
Element Type	Composite Outlet Structure
Element Id	7697
Label	Depressional Storage Overflow
Time	(N/A)
Message	Reverse flow conditions encountered for one or more headwater elevations. Calculated reverse flows may be approximate.
Source	Warning

Message Id	39
Scenario	2 Yr-6hr
Element Type	Composite Outlet Structure
Element Id	7697
Label	Depressional Storage Overflow
Time	(N/A)
Message	Reverse flow conditions encountered for one or more headwater elevations. Calculated reverse flows may be approximate.
Source	Warning

Message Id	39
Scenario	2 Yr-3hr
Element Type	Composite Outlet Structure
Element Id	7697
Label	Depressional Storage Overflow
Time	(N/A)
Message	Reverse flow conditions encountered for one or more headwater elevations. Calculated reverse flows may be approximate.
Source	Warning

Message Id	39
Scenario	2 Yr-2hr
Element Type	Composite Outlet Structure
Element Id	7697
Label	Depressional Storage Overflow
Time	(N/A)
Message	Reverse flow conditions encountered for one or more headwater elevations. Calculated reverse flows may be approximate.
Source	Warning

Scenario Calculation Summary

Messages

Message Id	39
Scenario	2 Yr-1hr
Element Type	Composite Outlet Structure
Element Id	7697
Label	Depressional Storage Overflow
Time	(N/A)
Message	Reverse flow conditions encountered for one or more headwater elevations. Calculated reverse flows may be approximate.
Source	Warning

Message Id	-1
Scenario	2 Yr-24hr
Element Type	Composite Outlet Structure
Element Id	5390
Label	TAM7
Time	(N/A)
Message	A user defined rating table is being used with a non-free outfall tailwater setting. For user defined rating tables it is suggested to use only free outfall tailwater as tailwater effects are not handled.
Source	Precalculation

Scenario Calculation Summary

Scenario Summary			
ID	7988		
Label	2 Yr-12hr		
Notes			
Active Topology	<I> Base Active Topology		
Hydrology	<I> Base Hydrology		
Rainfall Runoff	2Yr - 12 Hr		
Physical	<I> Base Physical		
Initial Condition	<I> Base Initial Condition		
Boundary Condition	<I> Base Boundary Condition		
Infiltration and Inflow	<I> Base Infiltration and Inflow		
Output	<I> Base Output		
User Data Extensions	<I> Base User Data Extensions		
PondPack Engine Calculation Options	<I> 12Hr		
Output Summary			
Output Increment	0.100 hours	Duration	48.000 hours
Rainfall Summary			
Return Event Tag	12 Hr	Rainfall Type	Time-Depth Curve
Total Depth	2.9 in	Storm Event	2YR-12HR
ICPM Output Summary			
Target Convergence	0.00 ft ³ /s	ICPM Time Step	0.100 hours
Maximum Iterations	35		

Executive Summary (Nodes)

Label	Scenario	Return Event (years)	Truncation	Hydrograph Volume (ac-ft)	Time to Peak (hours)	Peak Flow (ft ³ /s)	Maximum Water Surface Elevation (ft)	Maximum Pond Storage (ac-ft)
001	2 Yr-12hr	2	None	1.084	6.100	3.02	(N/A)	(N/A)
002	2 Yr-12hr	2	None	0.147	6.000	0.39	(N/A)	(N/A)
003	2 Yr-12hr	2	None	0.013	6.000	0.04	(N/A)	(N/A)
004	2 Yr-12hr	2	None	0.071	5.600	0.19	(N/A)	(N/A)
005	2 Yr-12hr	2	None	0.026	6.000	0.08	(N/A)	(N/A)
101	2 Yr-12hr	2	None	0.136	6.000	0.39	(N/A)	(N/A)
102	2 Yr-12hr	2	None	0.005	6.000	0.02	(N/A)	(N/A)
APN2	2 Yr-12hr	2	None	0.704	6.000	1.96	(N/A)	(N/A)
APN3	2 Yr-12hr	2	None	6.118	5.200	15.67	(N/A)	(N/A)
APN3 (IN)	2 Yr-12hr	2	None	6.118	5.200	15.67	(N/A)	(N/A)
APN3 (OUT)	2 Yr-12hr	2	None	6.064	8.000	7.77	681.46	2.706
APN4 (IN)	2 Yr-12hr	2	None	1.836	5.700	4.75	(N/A)	(N/A)
APN4 (OUT)	2 Yr-12hr	2	None	1.804	7.400	3.00	681.39	0.724
APN4	2 Yr-12hr	2	None	1.836	5.700	4.75	(N/A)	(N/A)

Scenario Calculation Summary

Executive Summary (Nodes)

Label	Scenario	Return Event (years)	Truncation	Hydrograph Volume (ac-ft)	Time to Peak (hours)	Peak Flow (ft ³ /s)	Maximum Water Surface Elevation (ft)	Maximum Pond Storage (ac-ft)
APN5 (IN)	2 Yr-12hr	2	None	6.029	6.100	13.17	(N/A)	(N/A)
APN5 (OUT)	2 Yr-12hr	2	None	5.963	10.500	4.35	678.75	3.058
APN5	2 Yr-12hr	2	None	4.225	5.800	10.90	(N/A)	(N/A)
APN6 (IN)	2 Yr-12hr	2	None	10.786	6.200	16.40	(N/A)	(N/A)
APN6 (OUT)	2 Yr-12hr	2	None	9.798	13.200	4.31	668.70	5.528
APN6	2 Yr-12hr	2	None	4.824	6.100	12.88	(N/A)	(N/A)
ASH4	2 Yr-12hr	2	None	0.481	5.100	1.27	(N/A)	(N/A)
CLOW CREEK OUTFALL OFF-SITE	2 Yr-12hr	2	None	300.053	9.400	251.34	(N/A)	(N/A)
CREEK OUTFALL 1	2 Yr-12hr	2	None	96.028	12.200	82.38	(N/A)	(N/A)
CREEK OUTFALL 2	2 Yr-12hr	2	None	152.418	0.100	168.35	(N/A)	(N/A)
J-5	2 Yr-12hr	2	None	253.981	7.700	227.16	(N/A)	(N/A)
J-6	2 Yr-12hr	2	None	4.439	5.100	11.69	(N/A)	(N/A)
Offsite Flow (East)	2 Yr-12hr	2	None	0.026	6.000	0.08	(N/A)	(N/A)
Offsite Flow (South)	2 Yr-12hr	2	None	0.071	5.600	0.19	(N/A)	(N/A)
Offsite Flow (West)	2 Yr-12hr	2	None	0.013	6.000	0.04	(N/A)	(N/A)
On-Site Depressional Storage (IN)	2 Yr-12hr	2	None	0.147	6.000	0.39	(N/A)	(N/A)
On-Site Depressional Storage (OUT)	2 Yr-12hr	2	None	0.000	0.000	0.00	651.07	0.147
PR1	2 Yr-12hr	2	None	2.213	5.100	5.83	(N/A)	(N/A)
PR2	2 Yr-12hr	2	None	1.091	5.100	2.87	(N/A)	(N/A)
PR3	2 Yr-12hr	2	None	0.655	5.100	1.73	(N/A)	(N/A)
TAM1 (IN)	2 Yr-12hr	2	None	274.166	7.700	257.68	(N/A)	(N/A)
TAM1 (OUT)	2 Yr-12hr	2	None	273.757	8.500	239.82	663.52	19.663
TAM1	2 Yr-12hr	2	None	14.121	5.700	36.71	(N/A)	(N/A)
TAM2 (IN)	2 Yr-12hr	2	None	10.610	12.000	4.58	(N/A)	(N/A)
TAM2 (OUT)	2 Yr-12hr	2	None	10.254	12.200	4.38	663.33	0.693
TAM2	2 Yr-12hr	2	None	0.812	5.000	2.15	(N/A)	(N/A)
TAM3 (IN)	2 Yr-12hr	2	None	11.426	7.600	4.91	(N/A)	(N/A)

Scenario Calculation Summary

Executive Summary (Nodes)

Label	Scenario	Return Event (years)	Truncation	Hydrograph Volume (ac-ft)	Time to Peak (hours)	Peak Flow (ft ³ /s)	Maximum Water Surface Elevation (ft)	Maximum Pond Storage (ac-ft)
TAM3 (OUT)	2 Yr-12hr	2	None	11.326	12.300	4.59	662.45	0.716
TAM3	2 Yr-12hr	2	None	1.172	5.100	3.07	(N/A)	(N/A)
TAM4 (IN)	2 Yr-12hr	2	None	18.155	6.100	19.82	(N/A)	(N/A)
TAM4 (OUT)	2 Yr-12hr	2	None	16.566	8.800	10.67	661.75	4.233
TAM4	2 Yr-12hr	2	None	6.829	5.800	17.43	(N/A)	(N/A)
TAM5 (IN)	2 Yr-12hr	2	None	17.772	8.200	11.73	(N/A)	(N/A)
TAM5 (OUT)	2 Yr-12hr	2	None	17.383	12.300	9.23	658.65	2.355
TAM5	2 Yr-12hr	2	None	1.207	5.100	3.14	(N/A)	(N/A)
TAM6 (IN)	2 Yr-12hr	2	None	275.565	8.500	241.95	(N/A)	(N/A)
TAM6 (OUT)	2 Yr-12hr	2	None	275.367	8.800	239.55	657.78	4.260
TAM6	2 Yr-12hr	2	None	1.808	6.000	4.96	(N/A)	(N/A)
TAM7 (IN)	2 Yr-12hr	2	None	299.925	8.800	254.09	(N/A)	(N/A)
TAM7 (OUT)	2 Yr-12hr	2	None	298.839	9.300	250.21	654.25	12.046
TAM7	2 Yr-12hr	2	None	7.175	6.000	18.67	(N/A)	(N/A)
West Tributary - Clow Creek (IN)	2 Yr-12hr	2	None	300.065	9.300	251.38	(N/A)	(N/A)
West Tributary - Clow Creek (OUT)	2 Yr-12hr	2	None	300.053	9.400	251.34	649.63	0.119

Executive Summary (Links)

Label	Type	Location	Hydrograph Volume (ac-ft)	Peak Time (hours)	Peak Flow (ft ³ /s)	End Point	Node Flow Direction
APN3 Outlet	Pond Outlet	Upstream	6.118	5.200	15.67	APN3	Pond Inflow
APN3 Outlet	Pond Outlet	Outflow	6.064	8.000	7.77	APN3	Pond Outflow
APN3 Outlet	Pond Outlet	Link	6.064	8.000	7.77		
APN3 Outlet	Pond Outlet	Downstream	274.166	7.700	257.68	TAM1	
APN4 Outlet	Pond Outlet	Upstream	1.836	5.700	4.75	APN4	Pond Inflow
APN4 Outlet	Pond Outlet	Outflow	1.804	7.400	3.00	APN4	Pond Outflow
APN4 Outlet	Pond Outlet	Link	1.804	7.400	3.00		
APN4 Outlet	Pond Outlet	Downstream	6.029	6.100	13.17	APN5	
APN5 Outlet	Pond Outlet	Upstream	6.029	6.100	13.17	APN5	Pond Inflow
APN5 Outlet	Pond Outlet	Outflow	5.963	10.500	4.35	APN5	Pond Outflow

Scenario Calculation Summary

Executive Summary (Links)

Label	Type	Location	Hydrograph Volume (ac-ft)	Peak Time (hours)	Peak Flow (ft ³ /s)	End Point	Node Flow Direction
APN5 Outlet	Pond Outlet	Link	5.962	10.500	4.35		
APN5 Outlet	Pond Outlet	Downstream	10.786	6.200	16.40	APN6	
APN6 Outlet	Pond Outlet	Upstream	10.786	6.200	16.40	APN6	Pond Inflow
APN6 Outlet	Pond Outlet	Outflow	9.798	13.200	4.31	APN6	Pond Outflow
APN6 Outlet	Pond Outlet	Link	9.798	13.200	4.31		
APN6 Outlet	Pond Outlet	Downstream	10.610	12.000	4.58	TAM2	
CO-3	Channel	Upstream	253.981	7.700	227.16	J-5	
CO-3	Channel	Link	253.981	7.800	227.16		
CO-3	Channel	Downstream	274.166	7.700	257.68	TAM1	
CO-4	Channel	Upstream	4.439	5.100	11.69	J-6	
CO-4	Channel	Link	4.439	5.200	11.69		
CO-4	Channel	Downstream	253.981	7.700	227.16	J-5	
OFFSITE FLOW	Pond Outlet	Upstream	300.065	9.300	251.38	West Tributary - Clow Creek	Pond Inflow
OFFSITE FLOW	Pond Outlet	Outflow	300.053	9.400	251.34	West Tributary - Clow Creek	Pond Outflow
OFFSITE FLOW	Pond Outlet	Link	300.053	9.400	251.34		
OFFSITE FLOW	Pond Outlet	Downstream	300.053	9.400	251.34	CLOW CREEK OUTFALL OFF-SITE	
OVERFLOW TO CREEK	Pond Outlet	Upstream	0.147	6.000	0.39	On-Site Depressional Storage	Pond Inflow
OVERFLOW TO CREEK	Pond Outlet	Outflow	0.000	0.000	0.00	On-Site Depressional Storage	Pond Outflow
OVERFLOW TO CREEK	Pond Outlet	Link	0.000	0.000	0.00		
OVERFLOW TO CREEK	Pond Outlet	Downstream	300.065	9.300	251.38	West Tributary - Clow Creek	
TAM1 OUTLET	Pond Outlet	Upstream	274.166	7.700	257.68	TAM1	Pond Inflow
TAM1 OUTLET	Pond Outlet	Outflow	273.757	8.500	239.82	TAM1	Pond Outflow
TAM1 OUTLET	Pond Outlet	Link	273.755	8.500	239.82		
TAM1 OUTLET	Pond Outlet	Downstream	275.565	8.500	241.95	TAM6	
TAM2 Outlet	Pond Outlet	Upstream	10.610	12.000	4.58	TAM2	Pond Inflow
TAM2 Outlet	Pond Outlet	Outflow	10.254	12.200	4.38	TAM2	Pond Outflow
TAM2 Outlet	Pond Outlet	Link	10.244	12.200	4.38		
TAM2 Outlet	Pond Outlet	Downstream	11.426	7.600	4.91	TAM3	

Scenario Calculation Summary

Executive Summary (Links)

Label	Type	Location	Hydrograph Volume (ac-ft)	Peak Time (hours)	Peak Flow (ft ³ /s)	End Point	Node Flow Direction
TAM3 Outlet	Pond Outlet	Upstream	11.426	7.600	4.91	TAM3	Pond Inflow
TAM3 Outlet	Pond Outlet	Outflow	11.326	12.300	4.59	TAM3	Pond Outflow
TAM3 Outlet	Pond Outlet	Link	11.326	12.300	4.59		
TAM3 Outlet	Pond Outlet	Downstream	18.155	6.100	19.82	TAM4	
TAM4 Outlet	Pond Outlet	Upstream	18.155	6.100	19.82	TAM4	Pond Inflow
TAM4 Outlet	Pond Outlet	Outflow	16.566	8.800	10.67	TAM4	Pond Outflow
TAM4 Outlet	Pond Outlet	Link	16.566	8.800	10.67		
TAM4 Outlet	Pond Outlet	Downstream	17.772	8.200	11.73	TAM5	
TAM5 Outlet	Pond Outlet	Upstream	17.772	8.200	11.73	TAM5	Pond Inflow
TAM5 Outlet	Pond Outlet	Outflow	17.383	12.300	9.23	TAM5	Pond Outflow
TAM5 Outlet	Pond Outlet	Link	17.383	12.300	9.23		
TAM5 Outlet	Pond Outlet	Downstream	299.925	8.800	254.09	TAM7	
TAM6	Pond Outlet	Upstream	275.565	8.500	241.95	TAM6	Pond Inflow
TAM6	Pond Outlet	Outflow	275.367	8.800	239.55	TAM6	Pond Outflow
TAM6	Pond Outlet	Link	275.365	8.800	239.55		
TAM6	Pond Outlet	Downstream	299.925	8.800	254.09	TAM7	
TAM7 Outlet	Pond Outlet	Upstream	299.925	8.800	254.09	TAM7	Pond Inflow
TAM7 Outlet	Pond Outlet	Outflow	298.839	9.300	250.21	TAM7	Pond Outflow
TAM7 Outlet	Pond Outlet	Link	298.816	9.300	250.21		
TAM7 Outlet	Pond Outlet	Downstream	300.065	9.300	251.38	West Tributary - Clow Creek	

Messages

Message Id	29
Scenario	2 Yr-24hr
Element Type	Catchment
Element Id	7688
Label	001
Time	(N/A)
Message	Tm > .25Tp. Computation increment, Tm, is greater than 1/4 Time to Peak on Unit Hydrograph. Using a larger Tc can solve this problem.
Source	Warning

Scenario Calculation Summary

Messages

Message Id	67
Scenario	2 Yr-24hr
Element Type	Composite Outlet Structure
Element Id	7699
Label	West Tributary Offsite Flow
Time	(N/A)
Message	Flow direction set to reverse for one ore more structures in composite outlet structure West Tributary Offsite Flow. To eliminate this warning, edit outlet data and select forward only. If reverse flow analysis is required, then the tailwater conditions must be set to interconnected pond.
Source	Warning
Message Id	67
Scenario	2 Yr-18hr
Element Type	Composite Outlet Structure
Element Id	7699
Label	West Tributary Offsite Flow
Time	(N/A)
Message	Flow direction set to reverse for one ore more structures in composite outlet structure West Tributary Offsite Flow. To eliminate this warning, edit outlet data and select forward only. If reverse flow analysis is required, then the tailwater conditions must be set to interconnected pond.
Source	Warning
Message Id	67
Scenario	2 Yr-12hr
Element Type	Composite Outlet Structure
Element Id	7699
Label	West Tributary Offsite Flow
Time	(N/A)
Message	Flow direction set to reverse for one ore more structures in composite outlet structure West Tributary Offsite Flow. To eliminate this warning, edit outlet data and select forward only. If reverse flow analysis is required, then the tailwater conditions must be set to interconnected pond.
Source	Warning
Message Id	67
Scenario	2 Yr-6hr
Element Type	Composite Outlet Structure
Element Id	7699
Label	West Tributary Offsite Flow
Time	(N/A)
Message	Flow direction set to reverse for one ore more structures in composite outlet structure West Tributary Offsite Flow. To eliminate this warning, edit outlet data and select forward only. If reverse flow analysis is required, then the tailwater conditions must be set to interconnected pond.
Source	Warning

Scenario Calculation Summary

Messages

Message Id	67
Scenario	2 Yr-3hr
Element Type	Composite Outlet Structure
Element Id	7699
Label	West Tributary Offsite Flow
Time	(N/A)
Message	Flow direction set to reverse for one ore more structures in composite outlet structure West Tributary Offsite Flow. To eliminate this warning, edit outlet data and select forward only. If reverse flow analysis is required, then the tailwater conditions must be set to interconnected pond.
Source	Warning
Message Id	67
Scenario	2 Yr-2hr
Element Type	Composite Outlet Structure
Element Id	7699
Label	West Tributary Offsite Flow
Time	(N/A)
Message	Flow direction set to reverse for one ore more structures in composite outlet structure West Tributary Offsite Flow. To eliminate this warning, edit outlet data and select forward only. If reverse flow analysis is required, then the tailwater conditions must be set to interconnected pond.
Source	Warning
Message Id	67
Scenario	2 Yr-1hr
Element Type	Composite Outlet Structure
Element Id	7699
Label	West Tributary Offsite Flow
Time	(N/A)
Message	Flow direction set to reverse for one ore more structures in composite outlet structure West Tributary Offsite Flow. To eliminate this warning, edit outlet data and select forward only. If reverse flow analysis is required, then the tailwater conditions must be set to interconnected pond.
Source	Warning
Message Id	39
Scenario	2 Yr-24hr
Element Type	Composite Outlet Structure
Element Id	7697
Label	Depressional Storage Overflow
Time	(N/A)
Message	Reverse flow conditions encountered for one or more headwater elevations. Calculated reverse flows may be approximate.
Source	Warning

Scenario Calculation Summary

Messages

Message Id	39
Scenario	2 Yr-18hr
Element Type	Composite Outlet Structure
Element Id	7697
Label	Depressional Storage Overflow
Time	(N/A)
Message	Reverse flow conditions encountered for one or more headwater elevations. Calculated reverse flows may be approximate.
Source	Warning

Message Id	39
Scenario	2 Yr-12hr
Element Type	Composite Outlet Structure
Element Id	7697
Label	Depressional Storage Overflow
Time	(N/A)
Message	Reverse flow conditions encountered for one or more headwater elevations. Calculated reverse flows may be approximate.
Source	Warning

Message Id	39
Scenario	2 Yr-6hr
Element Type	Composite Outlet Structure
Element Id	7697
Label	Depressional Storage Overflow
Time	(N/A)
Message	Reverse flow conditions encountered for one or more headwater elevations. Calculated reverse flows may be approximate.
Source	Warning

Message Id	39
Scenario	2 Yr-3hr
Element Type	Composite Outlet Structure
Element Id	7697
Label	Depressional Storage Overflow
Time	(N/A)
Message	Reverse flow conditions encountered for one or more headwater elevations. Calculated reverse flows may be approximate.
Source	Warning

Message Id	39
Scenario	2 Yr-2hr
Element Type	Composite Outlet Structure
Element Id	7697
Label	Depressional Storage Overflow
Time	(N/A)
Message	Reverse flow conditions encountered for one or more headwater elevations. Calculated reverse flows may be approximate.
Source	Warning

Scenario Calculation Summary

Messages

Message Id	39
Scenario	2 Yr-1hr
Element Type	Composite Outlet Structure
Element Id	7697
Label	Depressional Storage Overflow
Time	(N/A)
Message	Reverse flow conditions encountered for one or more headwater elevations. Calculated reverse flows may be approximate.
Source	Warning

Message Id	-1
Scenario	2 Yr-24hr
Element Type	Composite Outlet Structure
Element Id	5390
Label	TAM7
Time	(N/A)
Message	A user defined rating table is being used with a non-free outfall tailwater setting. For user defined rating tables it is suggested to use only free outfall tailwater as tailwater effects are not handled.
Source	Precalculation

Scenario Calculation Summary

Scenario Summary			
ID	7989		
Label	2 Yr-6hr		
Notes			
Active Topology	<I> Base Active Topology		
Hydrology	<I> Base Hydrology		
Rainfall Runoff	2Yr - 6Hr		
Physical	<I> Base Physical		
Initial Condition	<I> Base Initial Condition		
Boundary Condition	<I> Base Boundary Condition		
Infiltration and Inflow	<I> Base Infiltration and Inflow		
Output	<I> Base Output		
User Data Extensions	<I> Base User Data Extensions		
PondPack Engine Calculation Options	<I> 12Hr		
Output Summary			
Output Increment	0.100 hours	Duration	48.000 hours
Rainfall Summary			
Return Event Tag	12 Hr	Rainfall Type	Time-Depth Curve
Total Depth	2.5 in	Storm Event	2YR- 6HR
ICPM Output Summary			
Target Convergence	0.00 ft ³ /s	ICPM Time Step	0.100 hours
Maximum Iterations	35		

Executive Summary (Nodes)

Label	Scenario	Return Event (years)	Truncation	Hydrograph Volume (ac-ft)	Time to Peak (hours)	Peak Flow (ft ³ /s)	Maximum Water Surface Elevation (ft)	Maximum Pond Storage (ac-ft)
001	2 Yr-6hr	2	None	0.757	1.900	3.01	(N/A)	(N/A)
002	2 Yr-6hr	2	None	0.111	1.600	0.50	(N/A)	(N/A)
003	2 Yr-6hr	2	None	0.009	1.800	0.04	(N/A)	(N/A)
004	2 Yr-6hr	2	None	0.054	1.700	0.24	(N/A)	(N/A)
005	2 Yr-6hr	2	None	0.017	1.800	0.06	(N/A)	(N/A)
101	2 Yr-6hr	2	None	0.091	1.900	0.35	(N/A)	(N/A)
102	2 Yr-6hr	2	None	0.004	1.800	0.01	(N/A)	(N/A)
APN2	2 Yr-6hr	2	None	0.506	1.800	2.16	(N/A)	(N/A)
APN3	2 Yr-6hr	2	None	4.782	1.700	21.34	(N/A)	(N/A)
APN3 (IN)	2 Yr-6hr	2	None	4.782	1.700	21.34	(N/A)	(N/A)
APN3 (OUT)	2 Yr-6hr	2	None	4.738	4.400	7.01	681.38	2.377
APN4 (IN)	2 Yr-6hr	2	None	1.404	1.800	6.10	(N/A)	(N/A)
APN4 (OUT)	2 Yr-6hr	2	None	1.377	4.200	2.57	681.26	0.644
APN4	2 Yr-6hr	2	None	1.404	1.800	6.10	(N/A)	(N/A)

Scenario Calculation Summary

Executive Summary (Nodes)

Label	Scenario	Return Event (years)	Truncation	Hydrograph Volume (ac-ft)	Time to Peak (hours)	Peak Flow (ft ³ /s)	Maximum Water Surface Elevation (ft)	Maximum Pond Storage (ac-ft)
APN5 (IN)	2 Yr-6hr	2	None	4.603	1.900	14.69	(N/A)	(N/A)
APN5 (OUT)	2 Yr-6hr	2	None	4.544	6.400	4.07	678.59	2.515
APN5	2 Yr-6hr	2	None	3.226	1.900	13.81	(N/A)	(N/A)
APN6 (IN)	2 Yr-6hr	2	None	8.034	2.100	16.66	(N/A)	(N/A)
APN6 (OUT)	2 Yr-6hr	2	None	7.691	11.800	3.32	668.53	4.337
APN6	2 Yr-6hr	2	None	3.490	2.100	13.58	(N/A)	(N/A)
ASH4	2 Yr-6hr	2	None	0.369	1.600	1.70	(N/A)	(N/A)
CLOW CREEK OUTFALL OFF-SITE	2 Yr-6hr	2	None	287.916	9.800	212.40	(N/A)	(N/A)
CREEK OUTFALL 1	2 Yr-6hr	2	None	96.028	12.200	82.38	(N/A)	(N/A)
CREEK OUTFALL 2	2 Yr-6hr	2	None	152.418	0.100	168.35	(N/A)	(N/A)
J-5	2 Yr-6hr	2	None	252.765	7.800	219.21	(N/A)	(N/A)
J-6	2 Yr-6hr	2	None	3.422	1.600	15.84	(N/A)	(N/A)
Offsite Flow (East)	2 Yr-6hr	2	None	0.017	1.800	0.06	(N/A)	(N/A)
Offsite Flow (South)	2 Yr-6hr	2	None	0.054	1.700	0.24	(N/A)	(N/A)
Offsite Flow (West)	2 Yr-6hr	2	None	0.009	1.800	0.04	(N/A)	(N/A)
On-Site Depressional Storage (IN)	2 Yr-6hr	2	None	0.111	1.600	0.50	(N/A)	(N/A)
On-Site Depressional Storage (OUT)	2 Yr-6hr	2	None	0.000	0.000	0.00	651.04	0.111
PR1	2 Yr-6hr	2	None	1.707	1.600	7.91	(N/A)	(N/A)
PR2	2 Yr-6hr	2	None	0.841	1.600	3.90	(N/A)	(N/A)
PR3	2 Yr-6hr	2	None	0.505	1.600	2.34	(N/A)	(N/A)
TAM1 (IN)	2 Yr-6hr	2	None	268.229	7.900	224.22	(N/A)	(N/A)
TAM1 (OUT)	2 Yr-6hr	2	None	267.825	8.800	209.50	663.18	17.845
TAM1	2 Yr-6hr	2	None	10.726	1.800	46.94	(N/A)	(N/A)
TAM2 (IN)	2 Yr-6hr	2	None	8.324	6.000	3.58	(N/A)	(N/A)
TAM2 (OUT)	2 Yr-6hr	2	None	8.045	13.000	3.31	663.20	0.601
TAM2	2 Yr-6hr	2	None	0.633	1.500	2.97	(N/A)	(N/A)
TAM3 (IN)	2 Yr-6hr	2	None	8.953	1.700	4.49	(N/A)	(N/A)

Scenario Calculation Summary

Executive Summary (Nodes)

Label	Scenario	Return Event (years)	Truncation	Hydrograph Volume (ac-ft)	Time to Peak (hours)	Peak Flow (ft ³ /s)	Maximum Water Surface Elevation (ft)	Maximum Pond Storage (ac-ft)
TAM3 (OUT)	2 Yr-6hr	2	None	8.888	6.300	3.52	662.33	0.542
TAM3	2 Yr-6hr	2	None	0.908	1.600	4.19	(N/A)	(N/A)
TAM4 (IN)	2 Yr-6hr	2	None	14.160	1.900	24.13	(N/A)	(N/A)
TAM4 (OUT)	2 Yr-6hr	2	None	12.884	6.000	8.75	661.56	3.769
TAM4	2 Yr-6hr	2	None	5.272	1.900	22.27	(N/A)	(N/A)
TAM5 (IN)	2 Yr-6hr	2	None	13.841	5.200	9.61	(N/A)	(N/A)
TAM5 (OUT)	2 Yr-6hr	2	None	13.514	7.700	7.14	658.45	1.787
TAM5	2 Yr-6hr	2	None	0.957	1.600	4.45	(N/A)	(N/A)
TAM6 (IN)	2 Yr-6hr	2	None	269.128	8.800	209.50	(N/A)	(N/A)
TAM6 (OUT)	2 Yr-6hr	2	None	268.930	9.200	207.77	657.41	3.611
TAM6	2 Yr-6hr	2	None	1.302	1.800	5.49	(N/A)	(N/A)
TAM7 (IN)	2 Yr-6hr	2	None	287.861	9.200	214.66	(N/A)	(N/A)
TAM7 (OUT)	2 Yr-6hr	2	None	287.074	9.700	212.42	653.92	10.892
TAM7	2 Yr-6hr	2	None	5.417	1.900	22.61	(N/A)	(N/A)
West Tributary - Clow Creek (IN)	2 Yr-6hr	2	None	287.925	9.700	212.42	(N/A)	(N/A)
West Tributary - Clow Creek (OUT)	2 Yr-6hr	2	None	287.916	9.800	212.40	649.38	0.086

Executive Summary (Links)

Label	Type	Location	Hydrograph Volume (ac-ft)	Peak Time (hours)	Peak Flow (ft ³ /s)	End Point	Node Flow Direction
APN3 Outlet	Pond Outlet	Upstream	4.782	1.700	21.34	APN3	Pond Inflow
APN3 Outlet	Pond Outlet	Outflow	4.738	4.400	7.01	APN3	Pond Outflow
APN3 Outlet	Pond Outlet	Link	4.738	4.400	7.01		
APN3 Outlet	Pond Outlet	Downstream	268.229	7.900	224.22	TAM1	
APN4 Outlet	Pond Outlet	Upstream	1.404	1.800	6.10	APN4	Pond Inflow
APN4 Outlet	Pond Outlet	Outflow	1.377	4.200	2.57	APN4	Pond Outflow
APN4 Outlet	Pond Outlet	Link	1.377	4.200	2.57		
APN4 Outlet	Pond Outlet	Downstream	4.603	1.900	14.69	APN5	
APN5 Outlet	Pond Outlet	Upstream	4.603	1.900	14.69	APN5	Pond Inflow
APN5 Outlet	Pond Outlet	Outflow	4.544	6.400	4.07	APN5	Pond Outflow

Scenario Calculation Summary

Executive Summary (Links)

Label	Type	Location	Hydrograph Volume (ac-ft)	Peak Time (hours)	Peak Flow (ft ³ /s)	End Point	Node Flow Direction
APN5 Outlet	Pond Outlet	Link	4.544	6.400	4.07		
APN5 Outlet	Pond Outlet	Downstream	8.034	2.100	16.66	APN6	
APN6 Outlet	Pond Outlet	Upstream	8.034	2.100	16.66	APN6	Pond Inflow
APN6 Outlet	Pond Outlet	Outflow	7.691	11.800	3.32	APN6	Pond Outflow
APN6 Outlet	Pond Outlet	Link	7.687	11.800	3.32		
APN6 Outlet	Pond Outlet	Downstream	8.324	6.000	3.58	TAM2	
CO-3	Channel	Upstream	252.765	7.800	219.21	J-5	
CO-3	Channel	Link	252.765	7.900	219.21		
CO-3	Channel	Downstream	268.229	7.900	224.22	TAM1	
CO-4	Channel	Upstream	3.422	1.600	15.84	J-6	
CO-4	Channel	Link	3.422	1.700	15.84		
CO-4	Channel	Downstream	252.765	7.800	219.21	J-5	
OFFSITE FLOW	Pond Outlet	Upstream	287.925	9.700	212.42	West Tributary - Clow Creek	Pond Inflow
OFFSITE FLOW	Pond Outlet	Outflow	287.916	9.800	212.40	West Tributary - Clow Creek	Pond Outflow
OFFSITE FLOW	Pond Outlet	Link	287.916	9.800	212.40		
OFFSITE FLOW	Pond Outlet	Downstream	287.916	9.800	212.40	CLOW CREEK OUTFALL OFF-SITE	
OVERFLOW TO CREEK	Pond Outlet	Upstream	0.111	1.600	0.50	On-Site Depressional Storage	Pond Inflow
OVERFLOW TO CREEK	Pond Outlet	Outflow	0.000	0.000	0.00	On-Site Depressional Storage	Pond Outflow
OVERFLOW TO CREEK	Pond Outlet	Link	0.000	0.000	0.00		
OVERFLOW TO CREEK	Pond Outlet	Downstream	287.925	9.700	212.42	West Tributary - Clow Creek	
TAM1 OUTLET	Pond Outlet	Upstream	268.229	7.900	224.22	TAM1	Pond Inflow
TAM1 OUTLET	Pond Outlet	Outflow	267.825	8.800	209.50	TAM1	Pond Outflow
TAM1 OUTLET	Pond Outlet	Link	267.823	8.800	209.50		
TAM1 OUTLET	Pond Outlet	Downstream	269.128	8.800	209.50	TAM6	
TAM2 Outlet	Pond Outlet	Upstream	8.324	6.000	3.58	TAM2	Pond Inflow
TAM2 Outlet	Pond Outlet	Outflow	8.045	13.000	3.31	TAM2	Pond Outflow
TAM2 Outlet	Pond Outlet	Link	8.039	13.000	3.31		
TAM2 Outlet	Pond Outlet	Downstream	8.953	1.700	4.49	TAM3	

Scenario Calculation Summary

Executive Summary (Links)

Label	Type	Location	Hydrograph Volume (ac-ft)	Peak Time (hours)	Peak Flow (ft ³ /s)	End Point	Node Flow Direction
TAM3 Outlet	Pond Outlet	Upstream	8.953	1.700	4.49	TAM3	Pond Inflow
TAM3 Outlet	Pond Outlet	Outflow	8.888	6.300	3.52	TAM3	Pond Outflow
TAM3 Outlet	Pond Outlet	Link	8.888	6.300	3.52		
TAM3 Outlet	Pond Outlet	Downstream	14.160	1.900	24.13	TAM4	
TAM4 Outlet	Pond Outlet	Upstream	14.160	1.900	24.13	TAM4	Pond Inflow
TAM4 Outlet	Pond Outlet	Outflow	12.884	6.000	8.75	TAM4	Pond Outflow
TAM4 Outlet	Pond Outlet	Link	12.874	6.000	8.75		
TAM4 Outlet	Pond Outlet	Downstream	13.841	5.200	9.61	TAM5	
TAM5 Outlet	Pond Outlet	Upstream	13.841	5.200	9.61	TAM5	Pond Inflow
TAM5 Outlet	Pond Outlet	Outflow	13.514	7.700	7.14	TAM5	Pond Outflow
TAM5 Outlet	Pond Outlet	Link	13.514	7.700	7.14		
TAM5 Outlet	Pond Outlet	Downstream	287.861	9.200	214.66	TAM7	
TAM6	Pond Outlet	Upstream	269.128	8.800	209.50	TAM6	Pond Inflow
TAM6	Pond Outlet	Outflow	268.930	9.200	207.77	TAM6	Pond Outflow
TAM6	Pond Outlet	Link	268.928	9.200	207.77		
TAM6	Pond Outlet	Downstream	287.861	9.200	214.66	TAM7	
TAM7 Outlet	Pond Outlet	Upstream	287.861	9.200	214.66	TAM7	Pond Inflow
TAM7 Outlet	Pond Outlet	Outflow	287.074	9.700	212.42	TAM7	Pond Outflow
TAM7 Outlet	Pond Outlet	Link	287.056	9.700	212.42		
TAM7 Outlet	Pond Outlet	Downstream	287.925	9.700	212.42	West Tributary - Clow Creek	

Messages

Message Id	29
Scenario	2 Yr-24hr
Element Type	Catchment
Element Id	7688
Label	001
Time	(N/A)
Message	Tm > .25Tp. Computation increment, Tm, is greater than 1/4 Time to Peak on Unit Hydrograph. Using a larger Tc can solve this problem.
Source	Warning

Scenario Calculation Summary

Messages

Message Id	67
Scenario	2 Yr-24hr
Element Type	Composite Outlet Structure
Element Id	7699
Label	West Tributary Offsite Flow
Time	(N/A)
Message	Flow direction set to reverse for one ore more structures in composite outlet structure West Tributary Offsite Flow. To eliminate this warning, edit outlet data and select forward only. If reverse flow analysis is required, then the tailwater conditions must be set to interconnected pond.
Source	Warning
Message Id	67
Scenario	2 Yr-18hr
Element Type	Composite Outlet Structure
Element Id	7699
Label	West Tributary Offsite Flow
Time	(N/A)
Message	Flow direction set to reverse for one ore more structures in composite outlet structure West Tributary Offsite Flow. To eliminate this warning, edit outlet data and select forward only. If reverse flow analysis is required, then the tailwater conditions must be set to interconnected pond.
Source	Warning
Message Id	67
Scenario	2 Yr-12hr
Element Type	Composite Outlet Structure
Element Id	7699
Label	West Tributary Offsite Flow
Time	(N/A)
Message	Flow direction set to reverse for one ore more structures in composite outlet structure West Tributary Offsite Flow. To eliminate this warning, edit outlet data and select forward only. If reverse flow analysis is required, then the tailwater conditions must be set to interconnected pond.
Source	Warning
Message Id	67
Scenario	2 Yr-6hr
Element Type	Composite Outlet Structure
Element Id	7699
Label	West Tributary Offsite Flow
Time	(N/A)
Message	Flow direction set to reverse for one ore more structures in composite outlet structure West Tributary Offsite Flow. To eliminate this warning, edit outlet data and select forward only. If reverse flow analysis is required, then the tailwater conditions must be set to interconnected pond.
Source	Warning

Scenario Calculation Summary

Messages

Message Id	67
Scenario	2 Yr-3hr
Element Type	Composite Outlet Structure
Element Id	7699
Label	West Tributary Offsite Flow
Time	(N/A)
Message	Flow direction set to reverse for one ore more structures in composite outlet structure West Tributary Offsite Flow. To eliminate this warning, edit outlet data and select forward only. If reverse flow analysis is required, then the tailwater conditions must be set to interconnected pond.
Source	Warning
Message Id	67
Scenario	2 Yr-2hr
Element Type	Composite Outlet Structure
Element Id	7699
Label	West Tributary Offsite Flow
Time	(N/A)
Message	Flow direction set to reverse for one ore more structures in composite outlet structure West Tributary Offsite Flow. To eliminate this warning, edit outlet data and select forward only. If reverse flow analysis is required, then the tailwater conditions must be set to interconnected pond.
Source	Warning
Message Id	67
Scenario	2 Yr-1hr
Element Type	Composite Outlet Structure
Element Id	7699
Label	West Tributary Offsite Flow
Time	(N/A)
Message	Flow direction set to reverse for one ore more structures in composite outlet structure West Tributary Offsite Flow. To eliminate this warning, edit outlet data and select forward only. If reverse flow analysis is required, then the tailwater conditions must be set to interconnected pond.
Source	Warning
Message Id	39
Scenario	2 Yr-24hr
Element Type	Composite Outlet Structure
Element Id	7697
Label	Depressional Storage Overflow
Time	(N/A)
Message	Reverse flow conditions encountered for one or more headwater elevations. Calculated reverse flows may be approximate.
Source	Warning

Scenario Calculation Summary

Messages

Message Id	39
Scenario	2 Yr-18hr
Element Type	Composite Outlet Structure
Element Id	7697
Label	Depressional Storage Overflow
Time	(N/A)
Message	Reverse flow conditions encountered for one or more headwater elevations. Calculated reverse flows may be approximate.
Source	Warning

Message Id	39
Scenario	2 Yr-12hr
Element Type	Composite Outlet Structure
Element Id	7697
Label	Depressional Storage Overflow
Time	(N/A)
Message	Reverse flow conditions encountered for one or more headwater elevations. Calculated reverse flows may be approximate.
Source	Warning

Message Id	39
Scenario	2 Yr-6hr
Element Type	Composite Outlet Structure
Element Id	7697
Label	Depressional Storage Overflow
Time	(N/A)
Message	Reverse flow conditions encountered for one or more headwater elevations. Calculated reverse flows may be approximate.
Source	Warning

Message Id	39
Scenario	2 Yr-3hr
Element Type	Composite Outlet Structure
Element Id	7697
Label	Depressional Storage Overflow
Time	(N/A)
Message	Reverse flow conditions encountered for one or more headwater elevations. Calculated reverse flows may be approximate.
Source	Warning

Message Id	39
Scenario	2 Yr-2hr
Element Type	Composite Outlet Structure
Element Id	7697
Label	Depressional Storage Overflow
Time	(N/A)
Message	Reverse flow conditions encountered for one or more headwater elevations. Calculated reverse flows may be approximate.
Source	Warning

Scenario Calculation Summary

Messages

Message Id	39
Scenario	2 Yr-1hr
Element Type	Composite Outlet Structure
Element Id	7697
Label	Depressional Storage Overflow
Time	(N/A)
Message	Reverse flow conditions encountered for one or more headwater elevations. Calculated reverse flows may be approximate.
Source	Warning

Message Id	-1
Scenario	2 Yr-24hr
Element Type	Composite Outlet Structure
Element Id	5390
Label	TAM7
Time	(N/A)
Message	A user defined rating table is being used with a non-free outfall tailwater setting. For user defined rating tables it is suggested to use only free outfall tailwater as tailwater effects are not handled.
Source	Precalculation

Scenario Calculation Summary

Scenario Summary			
ID	7990		
Label	2 Yr-3hr		
Notes			
Active Topology	<I> Base Active Topology		
Hydrology	<I> Base Hydrology		
Rainfall Runoff	2Yr - 3 Hr		
Physical	<I> Base Physical		
Initial Condition	<I> Base Initial Condition		
Boundary Condition	<I> Base Boundary Condition		
Infiltration and Inflow	<I> Base Infiltration and Inflow		
Output	<I> Base Output		
User Data Extensions	<I> Base User Data Extensions		
PondPack Engine Calculation Options	<I> 12Hr		
Output Summary			
Output Increment	0.100 hours	Duration	48.000 hours
Rainfall Summary			
Return Event Tag	12 Hr	Rainfall Type	Time-Depth Curve
Total Depth	2.1 in	Storm Event	2YR- 3HR
ICPM Output Summary			
Target Convergence	0.00 ft ³ /s	ICPM Time Step	0.100 hours
Maximum Iterations	35		

Executive Summary (Nodes)

Label	Scenario	Return Event (years)	Truncation	Hydrograph Volume (ac-ft)	Time to Peak (hours)	Peak Flow (ft ³ /s)	Maximum Water Surface Elevation (ft)	Maximum Pond Storage (ac-ft)
001	2 Yr-3hr	2	None	0.492	1.200	3.19	(N/A)	(N/A)
002	2 Yr-3hr	2	None	0.080	1.000	0.65	(N/A)	(N/A)
003	2 Yr-3hr	2	None	0.006	1.000	0.04	(N/A)	(N/A)
004	2 Yr-3hr	2	None	0.039	1.000	0.31	(N/A)	(N/A)
005	2 Yr-3hr	2	None	0.010	1.700	0.07	(N/A)	(N/A)
101	2 Yr-3hr	2	None	0.056	1.800	0.35	(N/A)	(N/A)
102	2 Yr-3hr	2	None	0.002	1.700	0.01	(N/A)	(N/A)
APN2	2 Yr-3hr	2	None	0.342	1.000	2.58	(N/A)	(N/A)
APN3	2 Yr-3hr	2	None	3.609	1.100	27.32	(N/A)	(N/A)
APN3 (IN)	2 Yr-3hr	2	None	3.609	1.100	27.32	(N/A)	(N/A)
APN3 (OUT)	2 Yr-3hr	2	None	3.570	3.200	6.89	681.36	2.323
APN4 (IN)	2 Yr-3hr	2	None	1.031	1.100	7.43	(N/A)	(N/A)
APN4 (OUT)	2 Yr-3hr	2	None	1.007	3.000	2.51	681.24	0.635
APN4	2 Yr-3hr	2	None	1.031	1.100	7.43	(N/A)	(N/A)

Scenario Calculation Summary

Executive Summary (Nodes)

Label	Scenario	Return Event (years)	Truncation	Hydrograph Volume (ac-ft)	Time to Peak (hours)	Peak Flow (ft ³ /s)	Maximum Water Surface Elevation (ft)	Maximum Pond Storage (ac-ft)
APN5 (IN)	2 Yr-3hr	2	None	3.370	1.200	17.15	(N/A)	(N/A)
APN5 (OUT)	2 Yr-3hr	2	None	3.313	3.600	3.78	678.43	1.999
APN5	2 Yr-3hr	2	None	2.363	1.200	16.63	(N/A)	(N/A)
APN6 (IN)	2 Yr-3hr	2	None	5.697	1.400	17.53	(N/A)	(N/A)
APN6 (OUT)	2 Yr-3hr	2	None	5.507	10.600	2.54	668.40	3.323
APN6	2 Yr-3hr	2	None	2.384	1.400	14.56	(N/A)	(N/A)
ASH4	2 Yr-3hr	2	None	0.271	0.900	2.28	(N/A)	(N/A)
CLOW CREEK OUTFALL OFF-SITE	2 Yr-3hr	2	None	277.061	9.900	206.01	(N/A)	(N/A)
CREEK OUTFALL 1	2 Yr-3hr	2	None	96.028	12.200	82.38	(N/A)	(N/A)
CREEK OUTFALL 2	2 Yr-3hr	2	None	152.418	0.100	168.35	(N/A)	(N/A)
J-5	2 Yr-3hr	2	None	251.718	7.800	219.21	(N/A)	(N/A)
J-6	2 Yr-3hr	2	None	2.539	0.900	21.60	(N/A)	(N/A)
Offsite Flow (East)	2 Yr-3hr	2	None	0.010	1.700	0.07	(N/A)	(N/A)
Offsite Flow (South)	2 Yr-3hr	2	None	0.039	1.000	0.31	(N/A)	(N/A)
Offsite Flow (West)	2 Yr-3hr	2	None	0.006	1.000	0.04	(N/A)	(N/A)
On-Site Depressional Storage (IN)	2 Yr-3hr	2	None	0.080	1.000	0.65	(N/A)	(N/A)
On-Site Depressional Storage (OUT)	2 Yr-3hr	2	None	0.000	0.000	0.00	651.02	0.080
PR1	2 Yr-3hr	2	None	1.268	0.900	10.80	(N/A)	(N/A)
PR2	2 Yr-3hr	2	None	0.625	0.900	5.32	(N/A)	(N/A)
PR3	2 Yr-3hr	2	None	0.375	0.900	3.20	(N/A)	(N/A)
TAM1 (IN)	2 Yr-3hr	2	None	263.096	7.900	221.39	(N/A)	(N/A)
TAM1 (OUT)	2 Yr-3hr	2	None	262.694	8.900	205.47	663.13	17.599
TAM1	2 Yr-3hr	2	None	7.808	1.100	58.03	(N/A)	(N/A)
TAM2 (IN)	2 Yr-3hr	2	None	5.983	0.900	4.16	(N/A)	(N/A)
TAM2 (OUT)	2 Yr-3hr	2	None	5.818	11.500	2.51	663.10	0.520
TAM2	2 Yr-3hr	2	None	0.476	0.900	4.14	(N/A)	(N/A)
TAM3 (IN)	2 Yr-3hr	2	None	6.496	1.000	5.82	(N/A)	(N/A)

Scenario Calculation Summary

Executive Summary (Nodes)

Label	Scenario	Return Event (years)	Truncation	Hydrograph Volume (ac-ft)	Time to Peak (hours)	Peak Flow (ft ³ /s)	Maximum Water Surface Elevation (ft)	Maximum Pond Storage (ac-ft)
TAM3 (OUT)	2 Yr-3hr	2	None	6.458	3.200	2.81	662.24	0.413
TAM3	2 Yr-3hr	2	None	0.678	1.000	5.60	(N/A)	(N/A)
TAM4 (IN)	2 Yr-3hr	2	None	10.377	1.300	28.26	(N/A)	(N/A)
TAM4 (OUT)	2 Yr-3hr	2	None	9.378	3.500	7.25	661.40	3.388
TAM4	2 Yr-3hr	2	None	3.919	1.300	26.37	(N/A)	(N/A)
TAM5 (IN)	2 Yr-3hr	2	None	10.114	3.100	8.23	(N/A)	(N/A)
TAM5 (OUT)	2 Yr-3hr	2	None	9.838	5.800	5.19	658.25	1.198
TAM5	2 Yr-3hr	2	None	0.735	1.000	6.05	(N/A)	(N/A)
TAM6 (IN)	2 Yr-3hr	2	None	263.578	8.900	205.47	(N/A)	(N/A)
TAM6 (OUT)	2 Yr-3hr	2	None	263.381	9.300	203.74	657.36	3.526
TAM6	2 Yr-3hr	2	None	0.884	1.100	6.38	(N/A)	(N/A)
TAM7 (IN)	2 Yr-3hr	2	None	277.132	9.300	208.32	(N/A)	(N/A)
TAM7 (OUT)	2 Yr-3hr	2	None	276.518	9.800	206.02	653.86	10.723
TAM7	2 Yr-3hr	2	None	3.914	1.200	26.15	(N/A)	(N/A)
West Tributary - Clow Creek (IN)	2 Yr-3hr	2	None	277.068	9.800	206.02	(N/A)	(N/A)
West Tributary - Clow Creek (OUT)	2 Yr-3hr	2	None	277.061	9.900	206.01	649.34	0.081

Executive Summary (Links)

Label	Type	Location	Hydrograph Volume (ac-ft)	Peak Time (hours)	Peak Flow (ft ³ /s)	End Point	Node Flow Direction
APN3 Outlet	Pond Outlet	Upstream	3.609	1.100	27.32	APN3	Pond Inflow
APN3 Outlet	Pond Outlet	Outflow	3.570	3.200	6.89	APN3	Pond Outflow
APN3 Outlet	Pond Outlet	Link	3.570	3.200	6.89		
APN3 Outlet	Pond Outlet	Downstream	263.096	7.900	221.39	TAM1	
APN4 Outlet	Pond Outlet	Upstream	1.031	1.100	7.43	APN4	Pond Inflow
APN4 Outlet	Pond Outlet	Outflow	1.007	3.000	2.51	APN4	Pond Outflow
APN4 Outlet	Pond Outlet	Link	1.007	3.000	2.51		
APN4 Outlet	Pond Outlet	Downstream	3.370	1.200	17.15	APN5	
APN5 Outlet	Pond Outlet	Upstream	3.370	1.200	17.15	APN5	Pond Inflow
APN5 Outlet	Pond Outlet	Outflow	3.313	3.600	3.78	APN5	Pond Outflow

Scenario Calculation Summary

Executive Summary (Links)

Label	Type	Location	Hydrograph Volume (ac-ft)	Peak Time (hours)	Peak Flow (ft ³ /s)	End Point	Node Flow Direction
APN5 Outlet	Pond Outlet	Link	3.313	3.600	3.78		
APN5 Outlet	Pond Outlet	Downstream	5.697	1.400	17.53	APN6	
APN6 Outlet	Pond Outlet	Upstream	5.697	1.400	17.53	APN6	Pond Inflow
APN6 Outlet	Pond Outlet	Outflow	5.507	10.600	2.54	APN6	Pond Outflow
APN6 Outlet	Pond Outlet	Link	5.506	10.600	2.54		
APN6 Outlet	Pond Outlet	Downstream	5.983	0.900	4.16	TAM2	
CO-3	Channel	Upstream	251.718	7.800	219.21	J-5	
CO-3	Channel	Link	251.718	7.900	219.21		
CO-3	Channel	Downstream	263.096	7.900	221.39	TAM1	
CO-4	Channel	Upstream	2.539	0.900	21.60	J-6	
CO-4	Channel	Link	2.539	1.000	21.60		
CO-4	Channel	Downstream	251.718	7.800	219.21	J-5	
OFFSITE FLOW	Pond Outlet	Upstream	277.068	9.800	206.02	West Tributary - Clow Creek	Pond Inflow
OFFSITE FLOW	Pond Outlet	Outflow	277.061	9.900	206.01	West Tributary - Clow Creek	Pond Outflow
OFFSITE FLOW	Pond Outlet	Link	277.061	9.900	206.01		
OFFSITE FLOW	Pond Outlet	Downstream	277.061	9.900	206.01	CLOW CREEK OUTFALL OFF-SITE	
OVERFLOW TO CREEK	Pond Outlet	Upstream	0.080	1.000	0.65	On-Site Depressional Storage	Pond Inflow
OVERFLOW TO CREEK	Pond Outlet	Outflow	0.000	0.000	0.00	On-Site Depressional Storage	Pond Outflow
OVERFLOW TO CREEK	Pond Outlet	Link	0.000	0.000	0.00		
OVERFLOW TO CREEK	Pond Outlet	Downstream	277.068	9.800	206.02	West Tributary - Clow Creek	
TAM1 OUTLET	Pond Outlet	Upstream	263.096	7.900	221.39	TAM1	Pond Inflow
TAM1 OUTLET	Pond Outlet	Outflow	262.694	8.900	205.47	TAM1	Pond Outflow
TAM1 OUTLET	Pond Outlet	Link	262.692	8.900	205.47		
TAM1 OUTLET	Pond Outlet	Downstream	263.578	8.900	205.47	TAM6	
TAM2 Outlet	Pond Outlet	Upstream	5.983	0.900	4.16	TAM2	Pond Inflow
TAM2 Outlet	Pond Outlet	Outflow	5.818	11.500	2.51	TAM2	Pond Outflow
TAM2 Outlet	Pond Outlet	Link	5.818	11.500	2.51		
TAM2 Outlet	Pond Outlet	Downstream	6.496	1.000	5.82	TAM3	

Scenario Calculation Summary

Executive Summary (Links)

Label	Type	Location	Hydrograph Volume (ac-ft)	Peak Time (hours)	Peak Flow (ft ³ /s)	End Point	Node Flow Direction
TAM3 Outlet	Pond Outlet	Upstream	6.496	1.000	5.82	TAM3	Pond Inflow
TAM3 Outlet	Pond Outlet	Outflow	6.458	3.200	2.81	TAM3	Pond Outflow
TAM3 Outlet	Pond Outlet	Link	6.458	3.200	2.81		
TAM3 Outlet	Pond Outlet	Downstream	10.377	1.300	28.26	TAM4	
TAM4 Outlet	Pond Outlet	Upstream	10.377	1.300	28.26	TAM4	Pond Inflow
TAM4 Outlet	Pond Outlet	Outflow	9.378	3.500	7.25	TAM4	Pond Outflow
TAM4 Outlet	Pond Outlet	Link	9.378	3.500	7.25		
TAM4 Outlet	Pond Outlet	Downstream	10.114	3.100	8.23	TAM5	
TAM5 Outlet	Pond Outlet	Upstream	10.114	3.100	8.23	TAM5	Pond Inflow
TAM5 Outlet	Pond Outlet	Outflow	9.838	5.800	5.19	TAM5	Pond Outflow
TAM5 Outlet	Pond Outlet	Link	9.831	5.800	5.19		
TAM5 Outlet	Pond Outlet	Downstream	277.132	9.300	208.32	TAM7	
TAM6	Pond Outlet	Upstream	263.578	8.900	205.47	TAM6	Pond Inflow
TAM6	Pond Outlet	Outflow	263.381	9.300	203.74	TAM6	Pond Outflow
TAM6	Pond Outlet	Link	263.379	9.300	203.74		
TAM6	Pond Outlet	Downstream	277.132	9.300	208.32	TAM7	
TAM7 Outlet	Pond Outlet	Upstream	277.132	9.300	208.32	TAM7	Pond Inflow
TAM7 Outlet	Pond Outlet	Outflow	276.518	9.800	206.02	TAM7	Pond Outflow
TAM7 Outlet	Pond Outlet	Link	276.518	9.800	206.02		
TAM7 Outlet	Pond Outlet	Downstream	277.068	9.800	206.02	West Tributary - Clow Creek	

Messages

Message Id	29
Scenario	2 Yr-24hr
Element Type	Catchment
Element Id	7688
Label	001
Time	(N/A)
Message	Tm > .25Tp. Computation increment, Tm, is greater than 1/4 Time to Peak on Unit Hydrograph. Using a larger Tc can solve this problem.
Source	Warning

Scenario Calculation Summary

Messages

Message Id	67
Scenario	2 Yr-24hr
Element Type	Composite Outlet Structure
Element Id	7699
Label	West Tributary Offsite Flow
Time	(N/A)
Message	Flow direction set to reverse for one ore more structures in composite outlet structure West Tributary Offsite Flow. To eliminate this warning, edit outlet data and select forward only. If reverse flow analysis is required, then the tailwater conditions must be set to interconnected pond.
Source	Warning
Message Id	67
Scenario	2 Yr-18hr
Element Type	Composite Outlet Structure
Element Id	7699
Label	West Tributary Offsite Flow
Time	(N/A)
Message	Flow direction set to reverse for one ore more structures in composite outlet structure West Tributary Offsite Flow. To eliminate this warning, edit outlet data and select forward only. If reverse flow analysis is required, then the tailwater conditions must be set to interconnected pond.
Source	Warning
Message Id	67
Scenario	2 Yr-12hr
Element Type	Composite Outlet Structure
Element Id	7699
Label	West Tributary Offsite Flow
Time	(N/A)
Message	Flow direction set to reverse for one ore more structures in composite outlet structure West Tributary Offsite Flow. To eliminate this warning, edit outlet data and select forward only. If reverse flow analysis is required, then the tailwater conditions must be set to interconnected pond.
Source	Warning
Message Id	67
Scenario	2 Yr-6hr
Element Type	Composite Outlet Structure
Element Id	7699
Label	West Tributary Offsite Flow
Time	(N/A)
Message	Flow direction set to reverse for one ore more structures in composite outlet structure West Tributary Offsite Flow. To eliminate this warning, edit outlet data and select forward only. If reverse flow analysis is required, then the tailwater conditions must be set to interconnected pond.
Source	Warning

Scenario Calculation Summary

Messages

Message Id	67
Scenario	2 Yr-3hr
Element Type	Composite Outlet Structure
Element Id	7699
Label	West Tributary Offsite Flow
Time	(N/A)
Message	Flow direction set to reverse for one ore more structures in composite outlet structure West Tributary Offsite Flow. To eliminate this warning, edit outlet data and select forward only. If reverse flow analysis is required, then the tailwater conditions must be set to interconnected pond.
Source	Warning
Message Id	67
Scenario	2 Yr-2hr
Element Type	Composite Outlet Structure
Element Id	7699
Label	West Tributary Offsite Flow
Time	(N/A)
Message	Flow direction set to reverse for one ore more structures in composite outlet structure West Tributary Offsite Flow. To eliminate this warning, edit outlet data and select forward only. If reverse flow analysis is required, then the tailwater conditions must be set to interconnected pond.
Source	Warning
Message Id	67
Scenario	2 Yr-1hr
Element Type	Composite Outlet Structure
Element Id	7699
Label	West Tributary Offsite Flow
Time	(N/A)
Message	Flow direction set to reverse for one ore more structures in composite outlet structure West Tributary Offsite Flow. To eliminate this warning, edit outlet data and select forward only. If reverse flow analysis is required, then the tailwater conditions must be set to interconnected pond.
Source	Warning
Message Id	39
Scenario	2 Yr-24hr
Element Type	Composite Outlet Structure
Element Id	7697
Label	Depressional Storage Overflow
Time	(N/A)
Message	Reverse flow conditions encountered for one or more headwater elevations. Calculated reverse flows may be approximate.
Source	Warning

Scenario Calculation Summary

Messages

Message Id	39
Scenario	2 Yr-18hr
Element Type	Composite Outlet Structure
Element Id	7697
Label	Depressional Storage Overflow
Time	(N/A)
Message	Reverse flow conditions encountered for one or more headwater elevations. Calculated reverse flows may be approximate.
Source	Warning

Message Id	39
Scenario	2 Yr-12hr
Element Type	Composite Outlet Structure
Element Id	7697
Label	Depressional Storage Overflow
Time	(N/A)
Message	Reverse flow conditions encountered for one or more headwater elevations. Calculated reverse flows may be approximate.
Source	Warning

Message Id	39
Scenario	2 Yr-6hr
Element Type	Composite Outlet Structure
Element Id	7697
Label	Depressional Storage Overflow
Time	(N/A)
Message	Reverse flow conditions encountered for one or more headwater elevations. Calculated reverse flows may be approximate.
Source	Warning

Message Id	39
Scenario	2 Yr-3hr
Element Type	Composite Outlet Structure
Element Id	7697
Label	Depressional Storage Overflow
Time	(N/A)
Message	Reverse flow conditions encountered for one or more headwater elevations. Calculated reverse flows may be approximate.
Source	Warning

Message Id	39
Scenario	2 Yr-2hr
Element Type	Composite Outlet Structure
Element Id	7697
Label	Depressional Storage Overflow
Time	(N/A)
Message	Reverse flow conditions encountered for one or more headwater elevations. Calculated reverse flows may be approximate.
Source	Warning

Scenario Calculation Summary

Messages

Message Id	39
Scenario	2 Yr-1hr
Element Type	Composite Outlet Structure
Element Id	7697
Label	Depressional Storage Overflow
Time	(N/A)
Message	Reverse flow conditions encountered for one or more headwater elevations. Calculated reverse flows may be approximate.
Source	Warning

Message Id	-1
Scenario	2 Yr-24hr
Element Type	Composite Outlet Structure
Element Id	5390
Label	TAM7
Time	(N/A)
Message	A user defined rating table is being used with a non-free outfall tailwater setting. For user defined rating tables it is suggested to use only free outfall tailwater as tailwater effects are not handled.
Source	Precalculation

Scenario Calculation Summary

Scenario Summary	
ID	7991
Label	2 Yr-2hr
Notes	
Active Topology	<I> Base Active Topology
Hydrology	<I> Base Hydrology
Rainfall Runoff	2Yr - 2 Hr
Physical	<I> Base Physical
Initial Condition	<I> Base Initial Condition
Boundary Condition	<I> Base Boundary Condition
Infiltration and Inflow	<I> Base Infiltration and Inflow
Output	<I> Base Output
User Data Extensions	<I> Base User Data Extensions
PondPack Engine Calculation Options	<I> 12Hr

Output Summary			
Output Increment	0.100 hours	Duration	48.000 hours

Rainfall Summary			
Return Event Tag	12 Hr	Rainfall Type	Time-Depth Curve
Total Depth	1.9 in	Storm Event	2YR- 2HR

ICPM Output Summary			
Target Convergence	0.00 ft ³ /s	ICPM Time Step	0.100 hours
Maximum Iterations	35		

Executive Summary (Nodes)

Label	Scenario	Return Event (years)	Truncation	Hydrograph Volume (ac-ft)	Time to Peak (hours)	Peak Flow (ft ³ /s)	Maximum Water Surface Elevation (ft)	Maximum Pond Storage (ac-ft)
001	2 Yr-2hr	2	None	0.367	1.300	3.27	(N/A)	(N/A)
002	2 Yr-2hr	2	None	0.065	0.800	0.67	(N/A)	(N/A)
003	2 Yr-2hr	2	None	0.004	1.200	0.04	(N/A)	(N/A)
004	2 Yr-2hr	2	None	0.032	0.800	0.32	(N/A)	(N/A)
005	2 Yr-2hr	2	None	0.007	1.200	0.07	(N/A)	(N/A)
101	2 Yr-2hr	2	None	0.040	1.300	0.39	(N/A)	(N/A)
102	2 Yr-2hr	2	None	0.001	1.200	0.01	(N/A)	(N/A)
APN2	2 Yr-2hr	2	None	0.263	0.800	2.56	(N/A)	(N/A)
APN3	2 Yr-2hr	2	None	3.007	0.900	28.86	(N/A)	(N/A)
APN3 (IN)	2 Yr-2hr	2	None	3.007	0.900	28.86	(N/A)	(N/A)
APN3 (OUT)	2 Yr-2hr	2	None	2.970	2.300	6.51	681.32	2.149
APN4 (IN)	2 Yr-2hr	2	None	0.842	0.900	7.70	(N/A)	(N/A)
APN4 (OUT)	2 Yr-2hr	2	None	0.819	2.300	2.28	681.18	0.598
APN4	2 Yr-2hr	2	None	0.842	0.900	7.70	(N/A)	(N/A)

Scenario Calculation Summary

Executive Summary (Nodes)

Label	Scenario	Return Event (years)	Truncation	Hydrograph Volume (ac-ft)	Time to Peak (hours)	Peak Flow (ft ³ /s)	Maximum Water Surface Elevation (ft)	Maximum Pond Storage (ac-ft)
APN5 (IN)	2 Yr-2hr	2	None	2.748	1.000	17.58	(N/A)	(N/A)
APN5 (OUT)	2 Yr-2hr	2	None	2.692	2.700	3.57	678.32	1.641
APN5	2 Yr-2hr	2	None	1.929	1.000	17.12	(N/A)	(N/A)
APN6 (IN)	2 Yr-2hr	2	None	4.540	1.400	18.09	(N/A)	(N/A)
APN6 (OUT)	2 Yr-2hr	2	None	4.385	8.700	2.13	668.31	2.733
APN6	2 Yr-2hr	2	None	1.848	1.300	15.03	(N/A)	(N/A)
ASH4	2 Yr-2hr	2	None	0.222	0.700	2.52	(N/A)	(N/A)
CLOW CREEK OUTFALL OFF-SITE	2 Yr-2hr	2	None	271.570	9.900	204.14	(N/A)	(N/A)
CREEK OUTFALL 1	2 Yr-2hr	2	None	96.028	12.200	82.38	(N/A)	(N/A)
CREEK OUTFALL 2	2 Yr-2hr	2	None	152.418	0.100	168.35	(N/A)	(N/A)
J-5	2 Yr-2hr	2	None	251.191	7.800	219.21	(N/A)	(N/A)
J-6	2 Yr-2hr	2	None	2.090	0.700	23.98	(N/A)	(N/A)
Offsite Flow (East)	2 Yr-2hr	2	None	0.007	1.200	0.07	(N/A)	(N/A)
Offsite Flow (South)	2 Yr-2hr	2	None	0.032	0.800	0.32	(N/A)	(N/A)
Offsite Flow (West)	2 Yr-2hr	2	None	0.004	1.200	0.04	(N/A)	(N/A)
On-Site Depressional Storage (IN)	2 Yr-2hr	2	None	0.065	0.800	0.67	(N/A)	(N/A)
On-Site Depressional Storage (OUT)	2 Yr-2hr	2	None	0.000	0.000	0.00	651.00	0.065
PR1	2 Yr-2hr	2	None	1.044	0.700	12.00	(N/A)	(N/A)
PR2	2 Yr-2hr	2	None	0.515	0.700	5.91	(N/A)	(N/A)
PR3	2 Yr-2hr	2	None	0.309	0.700	3.55	(N/A)	(N/A)
TAM1 (IN)	2 Yr-2hr	2	None	260.503	7.900	220.47	(N/A)	(N/A)
TAM1 (OUT)	2 Yr-2hr	2	None	260.102	8.900	204.51	663.12	17.541
TAM1	2 Yr-2hr	2	None	6.342	0.900	59.92	(N/A)	(N/A)
TAM2 (IN)	2 Yr-2hr	2	None	4.781	0.700	4.64	(N/A)	(N/A)
TAM2 (OUT)	2 Yr-2hr	2	None	4.651	10.000	2.10	663.03	0.473
TAM2	2 Yr-2hr	2	None	0.396	0.700	4.63	(N/A)	(N/A)
TAM3 (IN)	2 Yr-2hr	2	None	5.211	0.700	6.24	(N/A)	(N/A)

Scenario Calculation Summary

Executive Summary (Nodes)

Label	Scenario	Return Event (years)	Truncation	Hydrograph Volume (ac-ft)	Time to Peak (hours)	Peak Flow (ft ³ /s)	Maximum Water Surface Elevation (ft)	Maximum Pond Storage (ac-ft)
TAM3 (OUT)	2 Yr-2hr	2	None	5.181	2.200	2.51	662.20	0.356
TAM3	2 Yr-2hr	2	None	0.560	0.700	6.12	(N/A)	(N/A)
TAM4 (IN)	2 Yr-2hr	2	None	8.412	1.100	29.21	(N/A)	(N/A)
TAM4 (OUT)	2 Yr-2hr	2	None	7.565	2.700	5.73	661.23	2.967
TAM4	2 Yr-2hr	2	None	3.230	1.100	27.33	(N/A)	(N/A)
TAM5 (IN)	2 Yr-2hr	2	None	8.185	0.800	6.73	(N/A)	(N/A)
TAM5 (OUT)	2 Yr-2hr	2	None	7.940	5.000	4.22	658.14	0.869
TAM5	2 Yr-2hr	2	None	0.620	0.800	6.62	(N/A)	(N/A)
TAM6 (IN)	2 Yr-2hr	2	None	260.784	8.900	204.51	(N/A)	(N/A)
TAM6 (OUT)	2 Yr-2hr	2	None	260.587	9.300	202.79	657.35	3.506
TAM6	2 Yr-2hr	2	None	0.682	0.900	6.27	(N/A)	(N/A)
TAM7 (IN)	2 Yr-2hr	2	None	271.688	9.300	206.43	(N/A)	(N/A)
TAM7 (OUT)	2 Yr-2hr	2	None	271.168	9.900	204.18	653.85	10.674
TAM7	2 Yr-2hr	2	None	3.162	1.100	26.82	(N/A)	(N/A)
West Tributary - Clow Creek (IN)	2 Yr-2hr	2	None	271.576	9.900	204.18	(N/A)	(N/A)
West Tributary - Clow Creek (OUT)	2 Yr-2hr	2	None	271.570	9.900	204.14	649.33	0.079

Executive Summary (Links)

Label	Type	Location	Hydrograph Volume (ac-ft)	Peak Time (hours)	Peak Flow (ft ³ /s)	End Point	Node Flow Direction
APN3 Outlet	Pond Outlet	Upstream	3.007	0.900	28.86	APN3	Pond Inflow
APN3 Outlet	Pond Outlet	Outflow	2.970	2.300	6.51	APN3	Pond Outflow
APN3 Outlet	Pond Outlet	Link	2.970	2.300	6.51		
APN3 Outlet	Pond Outlet	Downstream	260.503	7.900	220.47	TAM1	
APN4 Outlet	Pond Outlet	Upstream	0.842	0.900	7.70	APN4	Pond Inflow
APN4 Outlet	Pond Outlet	Outflow	0.819	2.300	2.28	APN4	Pond Outflow
APN4 Outlet	Pond Outlet	Link	0.819	2.300	2.28		
APN4 Outlet	Pond Outlet	Downstream	2.748	1.000	17.58	APN5	
APN5 Outlet	Pond Outlet	Upstream	2.748	1.000	17.58	APN5	Pond Inflow
APN5 Outlet	Pond Outlet	Outflow	2.692	2.700	3.57	APN5	Pond Outflow

Scenario Calculation Summary

Executive Summary (Links)

Label	Type	Location	Hydrograph Volume (ac-ft)	Peak Time (hours)	Peak Flow (ft ³ /s)	End Point	Node Flow Direction
APN5 Outlet	Pond Outlet	Link	2.692	2.700	3.57		
APN5 Outlet	Pond Outlet	Downstream	4.540	1.400	18.09	APN6	
APN6 Outlet	Pond Outlet	Upstream	4.540	1.400	18.09	APN6	Pond Inflow
APN6 Outlet	Pond Outlet	Outflow	4.385	8.700	2.13	APN6	Pond Outflow
APN6 Outlet	Pond Outlet	Link	4.385	8.700	2.13		
APN6 Outlet	Pond Outlet	Downstream	4.781	0.700	4.64	TAM2	
CO-3	Channel	Upstream	251.191	7.800	219.21	J-5	
CO-3	Channel	Link	251.191	7.900	219.21		
CO-3	Channel	Downstream	260.503	7.900	220.47	TAM1	
CO-4	Channel	Upstream	2.090	0.700	23.98	J-6	
CO-4	Channel	Link	2.090	0.800	23.98		
CO-4	Channel	Downstream	251.191	7.800	219.21	J-5	
OFFSITE FLOW	Pond Outlet	Upstream	271.576	9.900	204.18	West Tributary - Clow Creek	Pond Inflow
OFFSITE FLOW	Pond Outlet	Outflow	271.570	9.900	204.14	West Tributary - Clow Creek	Pond Outflow
OFFSITE FLOW	Pond Outlet	Link	271.570	9.900	204.14		
OFFSITE FLOW	Pond Outlet	Downstream	271.570	9.900	204.14	CLOW CREEK OUTFALL OFF-SITE	
OVERFLOW TO CREEK	Pond Outlet	Upstream	0.065	0.800	0.67	On-Site Depressional Storage	Pond Inflow
OVERFLOW TO CREEK	Pond Outlet	Outflow	0.000	0.000	0.00	On-Site Depressional Storage	Pond Outflow
OVERFLOW TO CREEK	Pond Outlet	Link	0.000	0.000	0.00		
OVERFLOW TO CREEK	Pond Outlet	Downstream	271.576	9.900	204.18	West Tributary - Clow Creek	
TAM1 OUTLET	Pond Outlet	Upstream	260.503	7.900	220.47	TAM1	Pond Inflow
TAM1 OUTLET	Pond Outlet	Outflow	260.102	8.900	204.51	TAM1	Pond Outflow
TAM1 OUTLET	Pond Outlet	Link	260.100	8.900	204.51		
TAM1 OUTLET	Pond Outlet	Downstream	260.784	8.900	204.51	TAM6	
TAM2 Outlet	Pond Outlet	Upstream	4.781	0.700	4.64	TAM2	Pond Inflow
TAM2 Outlet	Pond Outlet	Outflow	4.651	10.000	2.10	TAM2	Pond Outflow
TAM2 Outlet	Pond Outlet	Link	4.650	10.000	2.10		
TAM2 Outlet	Pond Outlet	Downstream	5.211	0.700	6.24	TAM3	

Scenario Calculation Summary

Executive Summary (Links)

Label	Type	Location	Hydrograph Volume (ac-ft)	Peak Time (hours)	Peak Flow (ft ³ /s)	End Point	Node Flow Direction
TAM3 Outlet	Pond Outlet	Upstream	5.211	0.700	6.24	TAM3	Pond Inflow
TAM3 Outlet	Pond Outlet	Outflow	5.181	2.200	2.51	TAM3	Pond Outflow
TAM3 Outlet	Pond Outlet	Link	5.180	2.200	2.51		
TAM3 Outlet	Pond Outlet	Downstream	8.412	1.100	29.21	TAM4	
TAM4 Outlet	Pond Outlet	Upstream	8.412	1.100	29.21	TAM4	Pond Inflow
TAM4 Outlet	Pond Outlet	Outflow	7.565	2.700	5.73	TAM4	Pond Outflow
TAM4 Outlet	Pond Outlet	Link	7.565	2.700	5.73		
TAM4 Outlet	Pond Outlet	Downstream	8.185	0.800	6.73	TAM5	
TAM5 Outlet	Pond Outlet	Upstream	8.185	0.800	6.73	TAM5	Pond Inflow
TAM5 Outlet	Pond Outlet	Outflow	7.940	5.000	4.22	TAM5	Pond Outflow
TAM5 Outlet	Pond Outlet	Link	7.940	5.000	4.22		
TAM5 Outlet	Pond Outlet	Downstream	271.688	9.300	206.43	TAM7	
TAM6	Pond Outlet	Upstream	260.784	8.900	204.51	TAM6	Pond Inflow
TAM6	Pond Outlet	Outflow	260.587	9.300	202.79	TAM6	Pond Outflow
TAM6	Pond Outlet	Link	260.585	9.300	202.79		
TAM6	Pond Outlet	Downstream	271.688	9.300	206.43	TAM7	
TAM7 Outlet	Pond Outlet	Upstream	271.688	9.300	206.43	TAM7	Pond Inflow
TAM7 Outlet	Pond Outlet	Outflow	271.168	9.900	204.18	TAM7	Pond Outflow
TAM7 Outlet	Pond Outlet	Link	271.156	9.900	204.18		
TAM7 Outlet	Pond Outlet	Downstream	271.576	9.900	204.18	West Tributary - Clow Creek	

Messages

Message Id	29
Scenario	2 Yr-24hr
Element Type	Catchment
Element Id	7688
Label	001
Time	(N/A)
Message	Tm > .25Tp. Computation increment, Tm, is greater than 1/4 Time to Peak on Unit Hydrograph. Using a larger Tc can solve this problem.
Source	Warning

Scenario Calculation Summary

Messages

Message Id	67
Scenario	2 Yr-24hr
Element Type	Composite Outlet Structure
Element Id	7699
Label	West Tributary Offsite Flow
Time	(N/A)
Message	Flow direction set to reverse for one ore more structures in composite outlet structure West Tributary Offsite Flow. To eliminate this warning, edit outlet data and select forward only. If reverse flow analysis is required, then the tailwater conditions must be set to interconnected pond.
Source	Warning
Message Id	67
Scenario	2 Yr-18hr
Element Type	Composite Outlet Structure
Element Id	7699
Label	West Tributary Offsite Flow
Time	(N/A)
Message	Flow direction set to reverse for one ore more structures in composite outlet structure West Tributary Offsite Flow. To eliminate this warning, edit outlet data and select forward only. If reverse flow analysis is required, then the tailwater conditions must be set to interconnected pond.
Source	Warning
Message Id	67
Scenario	2 Yr-12hr
Element Type	Composite Outlet Structure
Element Id	7699
Label	West Tributary Offsite Flow
Time	(N/A)
Message	Flow direction set to reverse for one ore more structures in composite outlet structure West Tributary Offsite Flow. To eliminate this warning, edit outlet data and select forward only. If reverse flow analysis is required, then the tailwater conditions must be set to interconnected pond.
Source	Warning
Message Id	67
Scenario	2 Yr-6hr
Element Type	Composite Outlet Structure
Element Id	7699
Label	West Tributary Offsite Flow
Time	(N/A)
Message	Flow direction set to reverse for one ore more structures in composite outlet structure West Tributary Offsite Flow. To eliminate this warning, edit outlet data and select forward only. If reverse flow analysis is required, then the tailwater conditions must be set to interconnected pond.
Source	Warning

Scenario Calculation Summary

Messages

Message Id	67
Scenario	2 Yr-3hr
Element Type	Composite Outlet Structure
Element Id	7699
Label	West Tributary Offsite Flow
Time	(N/A)
Message	Flow direction set to reverse for one ore more structures in composite outlet structure West Tributary Offsite Flow. To eliminate this warning, edit outlet data and select forward only. If reverse flow analysis is required, then the tailwater conditions must be set to interconnected pond.
Source	Warning
Message Id	67
Scenario	2 Yr-2hr
Element Type	Composite Outlet Structure
Element Id	7699
Label	West Tributary Offsite Flow
Time	(N/A)
Message	Flow direction set to reverse for one ore more structures in composite outlet structure West Tributary Offsite Flow. To eliminate this warning, edit outlet data and select forward only. If reverse flow analysis is required, then the tailwater conditions must be set to interconnected pond.
Source	Warning
Message Id	67
Scenario	2 Yr-1hr
Element Type	Composite Outlet Structure
Element Id	7699
Label	West Tributary Offsite Flow
Time	(N/A)
Message	Flow direction set to reverse for one ore more structures in composite outlet structure West Tributary Offsite Flow. To eliminate this warning, edit outlet data and select forward only. If reverse flow analysis is required, then the tailwater conditions must be set to interconnected pond.
Source	Warning
Message Id	39
Scenario	2 Yr-24hr
Element Type	Composite Outlet Structure
Element Id	7697
Label	Depressional Storage Overflow
Time	(N/A)
Message	Reverse flow conditions encountered for one or more headwater elevations. Calculated reverse flows may be approximate.
Source	Warning

Scenario Calculation Summary

Messages

Message Id	39
Scenario	2 Yr-18hr
Element Type	Composite Outlet Structure
Element Id	7697
Label	Depressional Storage Overflow
Time	(N/A)
Message	Reverse flow conditions encountered for one or more headwater elevations. Calculated reverse flows may be approximate.
Source	Warning

Message Id	39
Scenario	2 Yr-12hr
Element Type	Composite Outlet Structure
Element Id	7697
Label	Depressional Storage Overflow
Time	(N/A)
Message	Reverse flow conditions encountered for one or more headwater elevations. Calculated reverse flows may be approximate.
Source	Warning

Message Id	39
Scenario	2 Yr-6hr
Element Type	Composite Outlet Structure
Element Id	7697
Label	Depressional Storage Overflow
Time	(N/A)
Message	Reverse flow conditions encountered for one or more headwater elevations. Calculated reverse flows may be approximate.
Source	Warning

Message Id	39
Scenario	2 Yr-3hr
Element Type	Composite Outlet Structure
Element Id	7697
Label	Depressional Storage Overflow
Time	(N/A)
Message	Reverse flow conditions encountered for one or more headwater elevations. Calculated reverse flows may be approximate.
Source	Warning

Message Id	39
Scenario	2 Yr-2hr
Element Type	Composite Outlet Structure
Element Id	7697
Label	Depressional Storage Overflow
Time	(N/A)
Message	Reverse flow conditions encountered for one or more headwater elevations. Calculated reverse flows may be approximate.
Source	Warning

Scenario Calculation Summary

Messages

Message Id	39
Scenario	2 Yr-1hr
Element Type	Composite Outlet Structure
Element Id	7697
Label	Depressional Storage Overflow
Time	(N/A)
Message	Reverse flow conditions encountered for one or more headwater elevations. Calculated reverse flows may be approximate.
Source	Warning

Message Id	-1
Scenario	2 Yr-24hr
Element Type	Composite Outlet Structure
Element Id	5390
Label	TAM7
Time	(N/A)
Message	A user defined rating table is being used with a non-free outfall tailwater setting. For user defined rating tables it is suggested to use only free outfall tailwater as tailwater effects are not handled.
Source	Precalculation

Scenario Calculation Summary

Scenario Summary	
ID	7992
Label	2 Yr-1hr
Notes	
Active Topology	<I> Base Active Topology
Hydrology	<I> Base Hydrology
Rainfall Runoff	2Yr - 1 Hr
Physical	<I> Base Physical
Initial Condition	<I> Base Initial Condition
Boundary Condition	<I> Base Boundary Condition
Infiltration and Inflow	<I> Base Infiltration and Inflow
Output	<I> Base Output
User Data Extensions	<I> Base User Data Extensions
PondPack Engine Calculation Options	<I> 12Hr

Output Summary			
Output Increment	0.100 hours	Duration	48.000 hours

Rainfall Summary			
Return Event Tag	12 Hr	Rainfall Type	Time-Depth Curve
Total Depth	1.6 in	Storm Event	2YR- 1HR

ICPM Output Summary			
Target Convergence	0.00 ft ³ /s	ICPM Time Step	0.100 hours
Maximum Iterations	35		

Executive Summary (Nodes)

Label	Scenario	Return Event (years)	Truncation	Hydrograph Volume (ac-ft)	Time to Peak (hours)	Peak Flow (ft ³ /s)	Maximum Water Surface Elevation (ft)	Maximum Pond Storage (ac-ft)
001	2 Yr-1hr	2	None	0.177	0.800	2.88	(N/A)	(N/A)
002	2 Yr-1hr	2	None	0.039	0.600	0.64	(N/A)	(N/A)
003	2 Yr-1hr	2	None	0.002	0.700	0.04	(N/A)	(N/A)
004	2 Yr-1hr	2	None	0.019	0.600	0.31	(N/A)	(N/A)
005	2 Yr-1hr	2	None	0.002	0.700	0.05	(N/A)	(N/A)
101	2 Yr-1hr	2	None	0.016	0.800	0.31	(N/A)	(N/A)
102	2 Yr-1hr	2	None	0.001	0.800	0.01	(N/A)	(N/A)
APN2	2 Yr-1hr	2	None	0.139	0.700	2.39	(N/A)	(N/A)
APN3	2 Yr-1hr	2	None	1.973	0.700	28.13	(N/A)	(N/A)
APN3 (IN)	2 Yr-1hr	2	None	1.973	0.700	28.13	(N/A)	(N/A)
APN3 (OUT)	2 Yr-1hr	2	None	1.939	1.500	5.17	681.16	1.521
APN4 (IN)	2 Yr-1hr	2	None	0.525	0.800	7.40	(N/A)	(N/A)
APN4 (OUT)	2 Yr-1hr	2	None	0.504	1.600	1.29	680.90	0.427
APN4	2 Yr-1hr	2	None	0.525	0.800	7.40	(N/A)	(N/A)

Scenario Calculation Summary

Executive Summary (Nodes)

Label	Scenario	Return Event (years)	Truncation	Hydrograph Volume (ac-ft)	Time to Peak (hours)	Peak Flow (ft ³ /s)	Maximum Water Surface Elevation (ft)	Maximum Pond Storage (ac-ft)
APN5 (IN)	2 Yr-1hr	2	None	1.703	0.800	16.75	(N/A)	(N/A)
APN5 (OUT)	2 Yr-1hr	2	None	1.648	1.700	3.14	678.12	0.980
APN5	2 Yr-1hr	2	None	1.198	0.800	16.42	(N/A)	(N/A)
APN6 (IN)	2 Yr-1hr	2	None	2.644	1.000	16.23	(N/A)	(N/A)
APN6 (OUT)	2 Yr-1hr	2	None	2.528	5.700	1.41	668.16	1.580
APN6	2 Yr-1hr	2	None	0.995	1.000	13.35	(N/A)	(N/A)
ASH4	2 Yr-1hr	2	None	0.139	0.500	2.40	(N/A)	(N/A)
CLOW CREEK OUTFALL OFF-SITE	2 Yr-1hr	2	None	262.318	10.000	201.59	(N/A)	(N/A)
CREEK OUTFALL 1	2 Yr-1hr	2	None	96.028	12.200	82.38	(N/A)	(N/A)
CREEK OUTFALL 2	2 Yr-1hr	2	None	152.418	0.100	168.35	(N/A)	(N/A)
J-5	2 Yr-1hr	2	None	250.306	7.800	219.21	(N/A)	(N/A)
J-6	2 Yr-1hr	2	None	1.330	0.500	23.14	(N/A)	(N/A)
Offsite Flow (East)	2 Yr-1hr	2	None	0.002	0.700	0.05	(N/A)	(N/A)
Offsite Flow (South)	2 Yr-1hr	2	None	0.019	0.600	0.31	(N/A)	(N/A)
Offsite Flow (West)	2 Yr-1hr	2	None	0.002	0.700	0.04	(N/A)	(N/A)
On-Site Depressional Storage (IN)	2 Yr-1hr	2	None	0.039	0.600	0.64	(N/A)	(N/A)
On-Site Depressional Storage (OUT)	2 Yr-1hr	2	None	0.000	0.000	0.00	650.68	0.039
PR1	2 Yr-1hr	2	None	0.665	0.500	11.60	(N/A)	(N/A)
PR2	2 Yr-1hr	2	None	0.328	0.500	5.72	(N/A)	(N/A)
PR3	2 Yr-1hr	2	None	0.197	0.500	3.43	(N/A)	(N/A)
TAM1 (IN)	2 Yr-1hr	2	None	256.138	7.900	219.82	(N/A)	(N/A)
TAM1 (OUT)	2 Yr-1hr	2	None	255.738	8.900	203.72	663.11	17.493
TAM1	2 Yr-1hr	2	None	3.893	0.700	57.07	(N/A)	(N/A)
TAM2 (IN)	2 Yr-1hr	2	None	2.786	0.500	4.56	(N/A)	(N/A)
TAM2 (OUT)	2 Yr-1hr	2	None	2.696	8.300	1.36	662.91	0.379
TAM2	2 Yr-1hr	2	None	0.258	0.500	4.56	(N/A)	(N/A)
TAM3 (IN)	2 Yr-1hr	2	None	3.056	0.600	5.98	(N/A)	(N/A)

Scenario Calculation Summary

Executive Summary (Nodes)

Label	Scenario	Return Event (years)	Truncation	Hydrograph Volume (ac-ft)	Time to Peak (hours)	Peak Flow (ft ³ /s)	Maximum Water Surface Elevation (ft)	Maximum Pond Storage (ac-ft)
TAM3 (OUT)	2 Yr-1hr	2	None	3.036	1.300	1.96	662.11	0.238
TAM3	2 Yr-1hr	2	None	0.360	0.600	5.83	(N/A)	(N/A)
TAM4 (IN)	2 Yr-1hr	2	None	5.098	0.900	28.07	(N/A)	(N/A)
TAM4 (OUT)	2 Yr-1hr	2	None	4.474	2.200	2.85	660.84	2.032
TAM4	2 Yr-1hr	2	None	2.061	0.900	26.29	(N/A)	(N/A)
TAM5 (IN)	2 Yr-1hr	2	None	4.894	0.600	6.68	(N/A)	(N/A)
TAM5 (OUT)	2 Yr-1hr	2	None	4.696	3.300	2.64	657.92	0.436
TAM5	2 Yr-1hr	2	None	0.420	0.600	6.63	(N/A)	(N/A)
TAM6 (IN)	2 Yr-1hr	2	None	256.100	8.900	203.72	(N/A)	(N/A)
TAM6 (OUT)	2 Yr-1hr	2	None	255.903	9.400	202.02	657.34	3.490
TAM6	2 Yr-1hr	2	None	0.362	0.700	5.87	(N/A)	(N/A)
TAM7 (IN)	2 Yr-1hr	2	None	262.511	9.400	203.86	(N/A)	(N/A)
TAM7 (OUT)	2 Yr-1hr	2	None	262.129	9.900	201.62	653.82	10.606
TAM7	2 Yr-1hr	2	None	1.912	0.900	25.44	(N/A)	(N/A)
West Tributary - Clow Creek (IN)	2 Yr-1hr	2	None	262.322	9.900	201.62	(N/A)	(N/A)
West Tributary - Clow Creek (OUT)	2 Yr-1hr	2	None	262.318	10.000	201.59	649.31	0.077

Executive Summary (Links)

Label	Type	Location	Hydrograph Volume (ac-ft)	Peak Time (hours)	Peak Flow (ft ³ /s)	End Point	Node Flow Direction
APN3 Outlet	Pond Outlet	Upstream	1.973	0.700	28.13	APN3	Pond Inflow
APN3 Outlet	Pond Outlet	Outflow	1.939	1.500	5.17	APN3	Pond Outflow
APN3 Outlet	Pond Outlet	Link	1.939	1.500	5.17		
APN3 Outlet	Pond Outlet	Downstream	256.138	7.900	219.82	TAM1	
APN4 Outlet	Pond Outlet	Upstream	0.525	0.800	7.40	APN4	Pond Inflow
APN4 Outlet	Pond Outlet	Outflow	0.504	1.600	1.29	APN4	Pond Outflow
APN4 Outlet	Pond Outlet	Link	0.504	1.600	1.29		
APN4 Outlet	Pond Outlet	Downstream	1.703	0.800	16.75	APN5	
APN5 Outlet	Pond Outlet	Upstream	1.703	0.800	16.75	APN5	Pond Inflow
APN5 Outlet	Pond Outlet	Outflow	1.648	1.700	3.14	APN5	Pond Outflow

Scenario Calculation Summary

Executive Summary (Links)

Label	Type	Location	Hydrograph Volume (ac-ft)	Peak Time (hours)	Peak Flow (ft ³ /s)	End Point	Node Flow Direction
APN5 Outlet	Pond Outlet	Link	1.648	1.700	3.14		
APN5 Outlet	Pond Outlet	Downstream	2.644	1.000	16.23	APN6	
APN6 Outlet	Pond Outlet	Upstream	2.644	1.000	16.23	APN6	Pond Inflow
APN6 Outlet	Pond Outlet	Outflow	2.528	5.700	1.41	APN6	Pond Outflow
APN6 Outlet	Pond Outlet	Link	2.528	5.700	1.41		
APN6 Outlet	Pond Outlet	Downstream	2.786	0.500	4.56	TAM2	
CO-3	Channel	Upstream	250.306	7.800	219.21	J-5	
CO-3	Channel	Link	250.306	7.900	219.21		
CO-3	Channel	Downstream	256.138	7.900	219.82	TAM1	
CO-4	Channel	Upstream	1.330	0.500	23.14	J-6	
CO-4	Channel	Link	1.330	0.600	23.14		
CO-4	Channel	Downstream	250.306	7.800	219.21	J-5	
OFFSITE FLOW	Pond Outlet	Upstream	262.322	9.900	201.62	West Tributary - Clow Creek	Pond Inflow
OFFSITE FLOW	Pond Outlet	Outflow	262.318	10.000	201.59	West Tributary - Clow Creek	Pond Outflow
OFFSITE FLOW	Pond Outlet	Link	262.318	10.000	201.59		
OFFSITE FLOW	Pond Outlet	Downstream	262.318	10.000	201.59	CLOW CREEK OUTFALL OFF-SITE	
OVERFLOW TO CREEK	Pond Outlet	Upstream	0.039	0.600	0.64	On-Site Depressional Storage	Pond Inflow
OVERFLOW TO CREEK	Pond Outlet	Outflow	0.000	0.000	0.00	On-Site Depressional Storage	Pond Outflow
OVERFLOW TO CREEK	Pond Outlet	Link	0.000	0.000	0.00		
OVERFLOW TO CREEK	Pond Outlet	Downstream	262.322	9.900	201.62	West Tributary - Clow Creek	
TAM1 OUTLET	Pond Outlet	Upstream	256.138	7.900	219.82	TAM1	Pond Inflow
TAM1 OUTLET	Pond Outlet	Outflow	255.738	8.900	203.72	TAM1	Pond Outflow
TAM1 OUTLET	Pond Outlet	Link	255.736	8.900	203.72		
TAM1 OUTLET	Pond Outlet	Downstream	256.100	8.900	203.72	TAM6	
TAM2 Outlet	Pond Outlet	Upstream	2.786	0.500	4.56	TAM2	Pond Inflow
TAM2 Outlet	Pond Outlet	Outflow	2.696	8.300	1.36	TAM2	Pond Outflow
TAM2 Outlet	Pond Outlet	Link	2.695	8.300	1.36		
TAM2 Outlet	Pond Outlet	Downstream	3.056	0.600	5.98	TAM3	

Scenario Calculation Summary

Executive Summary (Links)

Label	Type	Location	Hydrograph Volume (ac-ft)	Peak Time (hours)	Peak Flow (ft ³ /s)	End Point	Node Flow Direction
TAM3 Outlet	Pond Outlet	Upstream	3.056	0.600	5.98	TAM3	Pond Inflow
TAM3 Outlet	Pond Outlet	Outflow	3.036	1.300	1.96	TAM3	Pond Outflow
TAM3 Outlet	Pond Outlet	Link	3.035	1.300	1.96		
TAM3 Outlet	Pond Outlet	Downstream	5.098	0.900	28.07	TAM4	
TAM4 Outlet	Pond Outlet	Upstream	5.098	0.900	28.07	TAM4	Pond Inflow
TAM4 Outlet	Pond Outlet	Outflow	4.474	2.200	2.85	TAM4	Pond Outflow
TAM4 Outlet	Pond Outlet	Link	4.472	2.200	2.85		
TAM4 Outlet	Pond Outlet	Downstream	4.894	0.600	6.68	TAM5	
TAM5 Outlet	Pond Outlet	Upstream	4.894	0.600	6.68	TAM5	Pond Inflow
TAM5 Outlet	Pond Outlet	Outflow	4.696	3.300	2.64	TAM5	Pond Outflow
TAM5 Outlet	Pond Outlet	Link	4.696	3.300	2.64		
TAM5 Outlet	Pond Outlet	Downstream	262.511	9.400	203.86	TAM7	
TAM6	Pond Outlet	Upstream	256.100	8.900	203.72	TAM6	Pond Inflow
TAM6	Pond Outlet	Outflow	255.903	9.400	202.02	TAM6	Pond Outflow
TAM6	Pond Outlet	Link	255.903	9.400	202.02		
TAM6	Pond Outlet	Downstream	262.511	9.400	203.86	TAM7	
TAM7 Outlet	Pond Outlet	Upstream	262.511	9.400	203.86	TAM7	Pond Inflow
TAM7 Outlet	Pond Outlet	Outflow	262.129	9.900	201.62	TAM7	Pond Outflow
TAM7 Outlet	Pond Outlet	Link	262.120	9.900	201.62		
TAM7 Outlet	Pond Outlet	Downstream	262.322	9.900	201.62	West Tributary - Clow Creek	

Messages

Message Id	29
Scenario	2 Yr-24hr
Element Type	Catchment
Element Id	7688
Label	001
Time	(N/A)
Message	Tm > .25Tp. Computation increment, Tm, is greater than 1/4 Time to Peak on Unit Hydrograph. Using a larger Tc can solve this problem.
Source	Warning

Scenario Calculation Summary

Messages

Message Id	67
Scenario	2 Yr-24hr
Element Type	Composite Outlet Structure
Element Id	7699
Label	West Tributary Offsite Flow
Time	(N/A)
Message	Flow direction set to reverse for one ore more structures in composite outlet structure West Tributary Offsite Flow. To eliminate this warning, edit outlet data and select forward only. If reverse flow analysis is required, then the tailwater conditions must be set to interconnected pond.
Source	Warning

Message Id	67
Scenario	2 Yr-18hr
Element Type	Composite Outlet Structure
Element Id	7699
Label	West Tributary Offsite Flow
Time	(N/A)
Message	Flow direction set to reverse for one ore more structures in composite outlet structure West Tributary Offsite Flow. To eliminate this warning, edit outlet data and select forward only. If reverse flow analysis is required, then the tailwater conditions must be set to interconnected pond.
Source	Warning

Message Id	67
Scenario	2 Yr-12hr
Element Type	Composite Outlet Structure
Element Id	7699
Label	West Tributary Offsite Flow
Time	(N/A)
Message	Flow direction set to reverse for one ore more structures in composite outlet structure West Tributary Offsite Flow. To eliminate this warning, edit outlet data and select forward only. If reverse flow analysis is required, then the tailwater conditions must be set to interconnected pond.
Source	Warning

Message Id	67
Scenario	2 Yr-6hr
Element Type	Composite Outlet Structure
Element Id	7699
Label	West Tributary Offsite Flow
Time	(N/A)
Message	Flow direction set to reverse for one ore more structures in composite outlet structure West Tributary Offsite Flow. To eliminate this warning, edit outlet data and select forward only. If reverse flow analysis is required, then the tailwater conditions must be set to interconnected pond.
Source	Warning

Scenario Calculation Summary

Messages

Message Id	67
Scenario	2 Yr-3hr
Element Type	Composite Outlet Structure
Element Id	7699
Label	West Tributary Offsite Flow
Time	(N/A)
Message	Flow direction set to reverse for one ore more structures in composite outlet structure West Tributary Offsite Flow. To eliminate this warning, edit outlet data and select forward only. If reverse flow analysis is required, then the tailwater conditions must be set to interconnected pond.
Source	Warning

Message Id	67
Scenario	2 Yr-2hr
Element Type	Composite Outlet Structure
Element Id	7699
Label	West Tributary Offsite Flow
Time	(N/A)
Message	Flow direction set to reverse for one ore more structures in composite outlet structure West Tributary Offsite Flow. To eliminate this warning, edit outlet data and select forward only. If reverse flow analysis is required, then the tailwater conditions must be set to interconnected pond.
Source	Warning

Message Id	67
Scenario	2 Yr-1hr
Element Type	Composite Outlet Structure
Element Id	7699
Label	West Tributary Offsite Flow
Time	(N/A)
Message	Flow direction set to reverse for one ore more structures in composite outlet structure West Tributary Offsite Flow. To eliminate this warning, edit outlet data and select forward only. If reverse flow analysis is required, then the tailwater conditions must be set to interconnected pond.
Source	Warning

Message Id	39
Scenario	2 Yr-24hr
Element Type	Composite Outlet Structure
Element Id	7697
Label	Depressional Storage Overflow
Time	(N/A)
Message	Reverse flow conditions encountered for one or more headwater elevations. Calculated reverse flows may be approximate.
Source	Warning

Scenario Calculation Summary

Messages

Message Id	39
Scenario	2 Yr-18hr
Element Type	Composite Outlet Structure
Element Id	7697
Label	Depressional Storage Overflow
Time	(N/A)
Message	Reverse flow conditions encountered for one or more headwater elevations. Calculated reverse flows may be approximate.
Source	Warning

Message Id	39
Scenario	2 Yr-12hr
Element Type	Composite Outlet Structure
Element Id	7697
Label	Depressional Storage Overflow
Time	(N/A)
Message	Reverse flow conditions encountered for one or more headwater elevations. Calculated reverse flows may be approximate.
Source	Warning

Message Id	39
Scenario	2 Yr-6hr
Element Type	Composite Outlet Structure
Element Id	7697
Label	Depressional Storage Overflow
Time	(N/A)
Message	Reverse flow conditions encountered for one or more headwater elevations. Calculated reverse flows may be approximate.
Source	Warning

Message Id	39
Scenario	2 Yr-3hr
Element Type	Composite Outlet Structure
Element Id	7697
Label	Depressional Storage Overflow
Time	(N/A)
Message	Reverse flow conditions encountered for one or more headwater elevations. Calculated reverse flows may be approximate.
Source	Warning

Message Id	39
Scenario	2 Yr-2hr
Element Type	Composite Outlet Structure
Element Id	7697
Label	Depressional Storage Overflow
Time	(N/A)
Message	Reverse flow conditions encountered for one or more headwater elevations. Calculated reverse flows may be approximate.
Source	Warning

Scenario Calculation Summary

Messages

Message Id	39
Scenario	2 Yr-1hr
Element Type	Composite Outlet Structure
Element Id	7697
Label	Depressional Storage Overflow
Time	(N/A)
Message	Reverse flow conditions encountered for one or more headwater elevations. Calculated reverse flows may be approximate.
Source	Warning

Message Id	-1
Scenario	2 Yr-24hr
Element Type	Composite Outlet Structure
Element Id	5390
Label	TAM7
Time	(N/A)
Message	A user defined rating table is being used with a non-free outfall tailwater setting. For user defined rating tables it is suggested to use only free outfall tailwater as tailwater effects are not handled.
Source	Precalculation

Scenario Calculation Summary

Scenario Summary	
ID	744
Label	100Yr-24Hr
Notes	
Active Topology	Base Active Topology
Hydrology	Base Hydrology
Rainfall Runoff	100Yr-24Hr
Physical	Base Physical
Initial Condition	Base Initial Condition
Boundary Condition	Base Boundary Condition
Infiltration and Inflow	Base Infiltration and Inflow
Output	Base Output
User Data Extensions	Base User Data Extensions
PondPack Engine Calculation Options	24Hr

Output Summary			
Output Increment	0.100 hours	Duration	120.000 hours

Rainfall Summary			
Return Event Tag	24 Hr	Rainfall Type	Time-Depth Curve
Total Depth	8.6 in	Storm Event	100YR-24HR

ICPM Output Summary			
Target Convergence	0.00 ft ³ /s	ICPM Time Step	0.100 hours
Maximum Iterations	35		

Executive Summary (Nodes)

Label	Scenario	Return Event (years)	Truncation	Hydrograph Volume (ac-ft)	Time to Peak (hours)	Peak Flow (ft ³ /s)	Maximum Water Surface Elevation (ft)	Maximum Pond Storage (ac-ft)
001	100Yr-24Hr	100	None	7.825	16.000	11.29	(N/A)	(N/A)
002	100Yr-24Hr	100	None	0.774	16.000	1.04	(N/A)	(N/A)
003	100Yr-24Hr	100	None	0.095	16.000	0.14	(N/A)	(N/A)
004	100Yr-24Hr	100	None	0.370	16.000	0.50	(N/A)	(N/A)
005	100Yr-24Hr	100	None	0.236	16.000	0.36	(N/A)	(N/A)
101	100Yr-24Hr	100	None	1.138	16.000	1.69	(N/A)	(N/A)
102	100Yr-24Hr	100	None	0.049	16.000	0.07	(N/A)	(N/A)
APN2	100Yr-24Hr	100	None	4.564	16.000	6.47	(N/A)	(N/A)
APN3	100Yr-24Hr	100	None	27.760	16.000	35.60	(N/A)	(N/A)
APN3 (IN)	100Yr-24Hr	100	None	27.760	16.000	35.60	(N/A)	(N/A)
APN3 (OUT)	100Yr-24Hr	100	None	27.753	20.300	12.42	683.24	14.262
APN4 (IN)	100Yr-24Hr	100	None	9.182	16.000	12.12	(N/A)	(N/A)
APN4 (OUT)	100Yr-24Hr	100	None	9.177	20.400	4.00	686.22	4.934
APN4	100Yr-24Hr	100	None	9.182	16.000	12.12	(N/A)	(N/A)

Scenario Calculation Summary

Executive Summary (Nodes)

Label	Scenario	Return Event (years)	Truncation	Hydrograph Volume (ac-ft)	Time to Peak (hours)	Peak Flow (ft ³ /s)	Maximum Water Surface Elevation (ft)	Maximum Pond Storage (ac-ft)
APN5 (IN)	100Yr-24Hr	100	None	30.434	16.100	31.77	(N/A)	(N/A)
APN5 (OUT)	100Yr-24Hr	100	None	30.397	20.200	14.82	681.10	15.490
APN5	100Yr-24Hr	100	None	21.258	16.100	28.10	(N/A)	(N/A)
APN6 (IN)	100Yr-24Hr	100	None	60.756	16.200	48.92	(N/A)	(N/A)
APN6 (OUT)	100Yr-24Hr	100	None	60.619	24.400	14.55	670.69	27.711
APN6	100Yr-24Hr	100	None	30.359	16.100	42.34	(N/A)	(N/A)
ASH4	100Yr-24Hr	100	None	2.383	16.000	3.15	(N/A)	(N/A)
CLOW CREEK OUTFALL OFF-SITE	100Yr-24Hr	100	None	965.214	19.100	390.67	(N/A)	(N/A)
CREEK OUTFALL 1	100Yr-24Hr	100	None	219.206	21.400	102.72	(N/A)	(N/A)
CREEK OUTFALL 2	100Yr-24Hr	100	None	469.501	0.100	168.35	(N/A)	(N/A)
J-5	100Yr-24Hr	100	None	714.668	18.000	251.81	(N/A)	(N/A)
J-6	100Yr-24Hr	100	None	21.397	16.000	28.07	(N/A)	(N/A)
Offsite Flow (East)	100Yr-24Hr	100	None	0.236	16.000	0.36	(N/A)	(N/A)
Offsite Flow (South)	100Yr-24Hr	100	None	0.370	16.000	0.50	(N/A)	(N/A)
Offsite Flow (West)	100Yr-24Hr	100	None	0.095	16.000	0.14	(N/A)	(N/A)
On-Site Depressional Storage (IN)	100Yr-24Hr	100	None	0.774	16.000	1.04	(N/A)	(N/A)
On-Site Depressional Storage (OUT)	100Yr-24Hr	100	None	0.000	0.000	0.00	651.57	0.774
PR1	100Yr-24Hr	100	None	10.630	16.000	13.93	(N/A)	(N/A)
PR2	100Yr-24Hr	100	None	5.239	16.000	6.87	(N/A)	(N/A)
PR3	100Yr-24Hr	100	None	3.146	16.000	4.12	(N/A)	(N/A)
TAM1 (IN)	100Yr-24Hr	100	None	814.675	17.100	345.51	(N/A)	(N/A)
TAM1 (OUT)	100Yr-24Hr	100	None	807.587	18.400	322.32	664.39	25.101
TAM1	100Yr-24Hr	100	None	72.626	16.000	96.74	(N/A)	(N/A)
TAM2 (IN)	100Yr-24Hr	100	None	64.346	17.000	17.32	(N/A)	(N/A)
TAM2 (OUT)	100Yr-24Hr	100	None	64.229	17.200	16.73	664.33	1.515
TAM2	100Yr-24Hr	100	None	3.727	16.000	4.82	(N/A)	(N/A)
TAM3 (IN)	100Yr-24Hr	100	None	69.756	17.000	23.44	(N/A)	(N/A)

Scenario Calculation Summary

Executive Summary (Nodes)

Label	Scenario	Return Event (years)	Truncation	Hydrograph Volume (ac-ft)	Time to Peak (hours)	Peak Flow (ft ³ /s)	Maximum Water Surface Elevation (ft)	Maximum Pond Storage (ac-ft)
TAM3 (OUT)	100Yr-24Hr	100	None	69.730	17.100	21.60	663.98	2.879
TAM3	100Yr-24Hr	100	None	5.527	16.000	7.19	(N/A)	(N/A)
TAM4 (IN)	100Yr-24Hr	100	None	102.435	16.300	62.38	(N/A)	(N/A)
TAM4 (OUT)	100Yr-24Hr	100	None	101.631	21.400	27.38	663.75	24.156
TAM4	100Yr-24Hr	100	None	32.705	16.100	42.56	(N/A)	(N/A)
TAM5 (IN)	100Yr-24Hr	100	None	106.765	18.100	30.70	(N/A)	(N/A)
TAM5 (OUT)	100Yr-24Hr	100	None	106.528	24.200	27.95	660.09	6.833
TAM5	100Yr-24Hr	100	None	5.134	16.000	6.45	(N/A)	(N/A)
TAM6 (IN)	100Yr-24Hr	100	None	819.177	18.200	333.02	(N/A)	(N/A)
TAM6 (OUT)	100Yr-24Hr	100	None	818.058	18.800	327.64	658.72	7.085
TAM6	100Yr-24Hr	100	None	11.590	16.000	16.35	(N/A)	(N/A)
TAM7 (IN)	100Yr-24Hr	100	None	962.436	18.300	386.54	(N/A)	(N/A)
TAM7 (OUT)	100Yr-24Hr	100	None	956.418	19.100	383.12	655.30	15.871
TAM7	100Yr-24Hr	100	None	37.850	16.100	50.65	(N/A)	(N/A)
West Tributary - Clow Creek (IN)	100Yr-24Hr	100	None	965.430	19.000	390.75	(N/A)	(N/A)
West Tributary - Clow Creek (OUT)	100Yr-24Hr	100	None	965.214	19.100	390.67	650.38	0.270

Executive Summary (Links)

Label	Type	Location	Hydrograph Volume (ac-ft)	Peak Time (hours)	Peak Flow (ft ³ /s)	End Point	Node Flow Direction
APN3 Outlet	Pond Outlet	Upstream	27.760	16.000	35.60	APN3	Pond Inflow
APN3 Outlet	Pond Outlet	Outflow	27.753	20.300	12.42	APN3	Pond Outflow
APN3 Outlet	Pond Outlet	Link	27.753	20.300	12.42		
APN3 Outlet	Pond Outlet	Downstream	814.675	17.100	345.51	TAM1	
APN4 Outlet	Pond Outlet	Upstream	9.182	16.000	12.12	APN4	Pond Inflow
APN4 Outlet	Pond Outlet	Outflow	9.177	20.400	4.00	APN4	Pond Outflow
APN4 Outlet	Pond Outlet	Link	9.177	20.400	4.00		
APN4 Outlet	Pond Outlet	Downstream	30.434	16.100	31.77	APN5	
APN5 Outlet	Pond Outlet	Upstream	30.434	16.100	31.77	APN5	Pond Inflow
APN5 Outlet	Pond Outlet	Outflow	30.397	20.200	14.82	APN5	Pond Outflow

Scenario Calculation Summary

Executive Summary (Links)

Label	Type	Location	Hydrograph Volume (ac-ft)	Peak Time (hours)	Peak Flow (ft ³ /s)	End Point	Node Flow Direction
APN5 Outlet	Pond Outlet	Link	30.397	20.200	14.82		
APN5 Outlet	Pond Outlet	Downstream	60.756	16.200	48.92	APN6	
APN6 Outlet	Pond Outlet	Upstream	60.756	16.200	48.92	APN6	Pond Inflow
APN6 Outlet	Pond Outlet	Outflow	60.619	24.400	14.55	APN6	Pond Outflow
APN6 Outlet	Pond Outlet	Link	60.619	24.400	14.55		
APN6 Outlet	Pond Outlet	Downstream	64.346	17.000	17.32	TAM2	
CO-3	Channel	Upstream	714.668	18.000	251.81	J-5	
CO-3	Channel	Link	714.668	18.100	251.81		
CO-3	Channel	Downstream	814.675	17.100	345.51	TAM1	
CO-4	Channel	Upstream	21.397	16.000	28.07	J-6	
CO-4	Channel	Link	21.397	16.100	28.07		
CO-4	Channel	Downstream	714.668	18.000	251.81	J-5	
OFFSITE FLOW	Pond Outlet	Upstream	965.430	19.000	390.75	West Tributary - Clow Creek	Pond Inflow
OFFSITE FLOW	Pond Outlet	Outflow	965.214	19.100	390.67	West Tributary - Clow Creek	Pond Outflow
OFFSITE FLOW	Pond Outlet	Link	965.214	19.100	390.67		
OFFSITE FLOW	Pond Outlet	Downstream	965.214	19.100	390.67	CLOW CREEK OFFFALL OFF-SITE	
OVERFLOW TO CREEK	Pond Outlet	Upstream	0.774	16.000	1.04	On-Site Depressional Storage	Pond Inflow
OVERFLOW TO CREEK	Pond Outlet	Outflow	0.000	0.000	0.00	On-Site Depressional Storage	Pond Outflow
OVERFLOW TO CREEK	Pond Outlet	Link	0.000	0.000	0.00		
OVERFLOW TO CREEK	Pond Outlet	Downstream	965.430	19.000	390.75	West Tributary - Clow Creek	
TAM1 OUTLET	Pond Outlet	Upstream	814.675	17.100	345.51	TAM1	Pond Inflow
TAM1 OUTLET	Pond Outlet	Outflow	807.587	18.400	322.32	TAM1	Pond Outflow
TAM1 OUTLET	Pond Outlet	Link	807.587	18.400	322.32		
TAM1 OUTLET	Pond Outlet	Downstream	819.177	18.200	333.02	TAM6	
TAM2 Outlet	Pond Outlet	Upstream	64.346	17.000	17.32	TAM2	Pond Inflow
TAM2 Outlet	Pond Outlet	Outflow	64.229	17.200	16.73	TAM2	Pond Outflow
TAM2 Outlet	Pond Outlet	Link	64.229	17.200	16.73		
TAM2 Outlet	Pond Outlet	Downstream	69.756	17.000	23.44	TAM3	

Scenario Calculation Summary

Executive Summary (Links)

Label	Type	Location	Hydrograph Volume (ac-ft)	Peak Time (hours)	Peak Flow (ft ³ /s)	End Point	Node Flow Direction
TAM3 Outlet	Pond Outlet	Upstream	69.756	17.000	23.44	TAM3	Pond Inflow
TAM3 Outlet	Pond Outlet	Outflow	69.730	17.100	21.60	TAM3	Pond Outflow
TAM3 Outlet	Pond Outlet	Link	69.728	17.100	21.60		
TAM3 Outlet	Pond Outlet	Downstream	102.435	16.300	62.38	TAM4	
TAM4 Outlet	Pond Outlet	Upstream	102.435	16.300	62.38	TAM4	Pond Inflow
TAM4 Outlet	Pond Outlet	Outflow	101.631	21.400	27.38	TAM4	Pond Outflow
TAM4 Outlet	Pond Outlet	Link	101.631	21.400	27.38		
TAM4 Outlet	Pond Outlet	Downstream	106.765	18.100	30.70	TAM5	
TAM5 Outlet	Pond Outlet	Upstream	106.765	18.100	30.70	TAM5	Pond Inflow
TAM5 Outlet	Pond Outlet	Outflow	106.528	24.200	27.95	TAM5	Pond Outflow
TAM5 Outlet	Pond Outlet	Link	106.524	24.200	27.95		
TAM5 Outlet	Pond Outlet	Downstream	962.436	18.300	386.54	TAM7	
TAM6	Pond Outlet	Upstream	819.177	18.200	333.02	TAM6	Pond Inflow
TAM6	Pond Outlet	Outflow	818.058	18.800	327.64	TAM6	Pond Outflow
TAM6	Pond Outlet	Link	818.058	18.800	327.64		
TAM6	Pond Outlet	Downstream	962.436	18.300	386.54	TAM7	
TAM7 Outlet	Pond Outlet	Upstream	962.436	18.300	386.54	TAM7	Pond Inflow
TAM7 Outlet	Pond Outlet	Outflow	956.418	19.100	383.12	TAM7	Pond Outflow
TAM7 Outlet	Pond Outlet	Link	956.418	19.100	383.12		
TAM7 Outlet	Pond Outlet	Downstream	965.430	19.000	390.75	West Tributary - Clow Creek	

Messages

Message Id	29
Scenario	2 Yr-24hr
Element Type	Catchment
Element Id	7688
Label	001
Time	(N/A)
Message	Tm > .25Tp. Computation increment, Tm, is greater than 1/4 Time to Peak on Unit Hydrograph. Using a larger Tc can solve this problem.
Source	Warning

Scenario Calculation Summary

Messages

Message Id	67
Scenario	2 Yr-24hr
Element Type	Composite Outlet Structure
Element Id	7699
Label	West Tributary Offsite Flow
Time	(N/A)
Message	Flow direction set to reverse for one ore more structures in composite outlet structure West Tributary Offsite Flow. To eliminate this warning, edit outlet data and select forward only. If reverse flow analysis is required, then the tailwater conditions must be set to interconnected pond.
Source	Warning
Message Id	67
Scenario	2 Yr-18hr
Element Type	Composite Outlet Structure
Element Id	7699
Label	West Tributary Offsite Flow
Time	(N/A)
Message	Flow direction set to reverse for one ore more structures in composite outlet structure West Tributary Offsite Flow. To eliminate this warning, edit outlet data and select forward only. If reverse flow analysis is required, then the tailwater conditions must be set to interconnected pond.
Source	Warning
Message Id	67
Scenario	2 Yr-12hr
Element Type	Composite Outlet Structure
Element Id	7699
Label	West Tributary Offsite Flow
Time	(N/A)
Message	Flow direction set to reverse for one ore more structures in composite outlet structure West Tributary Offsite Flow. To eliminate this warning, edit outlet data and select forward only. If reverse flow analysis is required, then the tailwater conditions must be set to interconnected pond.
Source	Warning
Message Id	67
Scenario	2 Yr-6hr
Element Type	Composite Outlet Structure
Element Id	7699
Label	West Tributary Offsite Flow
Time	(N/A)
Message	Flow direction set to reverse for one ore more structures in composite outlet structure West Tributary Offsite Flow. To eliminate this warning, edit outlet data and select forward only. If reverse flow analysis is required, then the tailwater conditions must be set to interconnected pond.
Source	Warning

Scenario Calculation Summary

Messages

Message Id	67
Scenario	2 Yr-3hr
Element Type	Composite Outlet Structure
Element Id	7699
Label	West Tributary Offsite Flow
Time	(N/A)
Message	Flow direction set to reverse for one ore more structures in composite outlet structure West Tributary Offsite Flow. To eliminate this warning, edit outlet data and select forward only. If reverse flow analysis is required, then the tailwater conditions must be set to interconnected pond.
Source	Warning
Message Id	67
Scenario	2 Yr-2hr
Element Type	Composite Outlet Structure
Element Id	7699
Label	West Tributary Offsite Flow
Time	(N/A)
Message	Flow direction set to reverse for one ore more structures in composite outlet structure West Tributary Offsite Flow. To eliminate this warning, edit outlet data and select forward only. If reverse flow analysis is required, then the tailwater conditions must be set to interconnected pond.
Source	Warning
Message Id	67
Scenario	2 Yr-1hr
Element Type	Composite Outlet Structure
Element Id	7699
Label	West Tributary Offsite Flow
Time	(N/A)
Message	Flow direction set to reverse for one ore more structures in composite outlet structure West Tributary Offsite Flow. To eliminate this warning, edit outlet data and select forward only. If reverse flow analysis is required, then the tailwater conditions must be set to interconnected pond.
Source	Warning
Message Id	39
Scenario	2 Yr-24hr
Element Type	Composite Outlet Structure
Element Id	7697
Label	Depressional Storage Overflow
Time	(N/A)
Message	Reverse flow conditions encountered for one or more headwater elevations. Calculated reverse flows may be approximate.
Source	Warning

Scenario Calculation Summary

Messages

Message Id	39
Scenario	2 Yr-18hr
Element Type	Composite Outlet Structure
Element Id	7697
Label	Depressional Storage Overflow
Time	(N/A)
Message	Reverse flow conditions encountered for one or more headwater elevations. Calculated reverse flows may be approximate.
Source	Warning

Message Id	39
Scenario	2 Yr-12hr
Element Type	Composite Outlet Structure
Element Id	7697
Label	Depressional Storage Overflow
Time	(N/A)
Message	Reverse flow conditions encountered for one or more headwater elevations. Calculated reverse flows may be approximate.
Source	Warning

Message Id	39
Scenario	2 Yr-6hr
Element Type	Composite Outlet Structure
Element Id	7697
Label	Depressional Storage Overflow
Time	(N/A)
Message	Reverse flow conditions encountered for one or more headwater elevations. Calculated reverse flows may be approximate.
Source	Warning

Message Id	39
Scenario	2 Yr-3hr
Element Type	Composite Outlet Structure
Element Id	7697
Label	Depressional Storage Overflow
Time	(N/A)
Message	Reverse flow conditions encountered for one or more headwater elevations. Calculated reverse flows may be approximate.
Source	Warning

Message Id	39
Scenario	2 Yr-2hr
Element Type	Composite Outlet Structure
Element Id	7697
Label	Depressional Storage Overflow
Time	(N/A)
Message	Reverse flow conditions encountered for one or more headwater elevations. Calculated reverse flows may be approximate.
Source	Warning

Scenario Calculation Summary

Messages

Message Id	39
Scenario	2 Yr-1hr
Element Type	Composite Outlet Structure
Element Id	7697
Label	Depressional Storage Overflow
Time	(N/A)
Message	Reverse flow conditions encountered for one or more headwater elevations. Calculated reverse flows may be approximate.
Source	Warning

Message Id	-1
Scenario	2 Yr-24hr
Element Type	Composite Outlet Structure
Element Id	5390
Label	TAM7
Time	(N/A)
Message	A user defined rating table is being used with a non-free outfall tailwater setting. For user defined rating tables it is suggested to use only free outfall tailwater as tailwater effects are not handled.
Source	Precalculation

Scenario Calculation Summary

Scenario Summary	
ID	741
Label	100Yr-18Hr
Notes	
Active Topology	Base Active Topology
Hydrology	Base Hydrology
Rainfall Runoff	100Yr-18Hr
Physical	Base Physical
Initial Condition	Base Initial Condition
Boundary Condition	Base Boundary Condition
Infiltration and Inflow	Base Infiltration and Inflow
Output	Base Output
User Data Extensions	Base User Data Extensions
PondPack Engine Calculation Options	18Hr

Output Summary			
Output Increment	0.100 hours	Duration	48.000 hours

Rainfall Summary			
Return Event Tag	18 Hr	Rainfall Type	Time-Depth Curve
Total Depth	8.1 in	Storm Event	100YR-18HR

ICPM Output Summary			
Target Convergence	0.00 ft ³ /s	ICPM Time Step	0.100 hours
Maximum Iterations	35		

Executive Summary (Nodes)

Label	Scenario	Return Event (years)	Truncation	Hydrograph Volume (ac-ft)	Time to Peak (hours)	Peak Flow (ft ³ /s)	Maximum Water Surface Elevation (ft)	Maximum Pond Storage (ac-ft)
001	100Yr-18Hr	100	None	7.135	12.100	13.81	(N/A)	(N/A)
002	100Yr-18Hr	100	None	0.714	12.000	1.29	(N/A)	(N/A)
003	100Yr-18Hr	100	None	0.087	12.000	0.17	(N/A)	(N/A)
004	100Yr-18Hr	100	None	0.341	12.000	0.61	(N/A)	(N/A)
005	100Yr-18Hr	100	None	0.213	12.000	0.43	(N/A)	(N/A)
101	100Yr-18Hr	100	None	1.033	12.000	2.06	(N/A)	(N/A)
102	100Yr-18Hr	100	None	0.044	12.000	0.09	(N/A)	(N/A)
APN2	100Yr-18Hr	100	None	4.176	12.000	7.94	(N/A)	(N/A)
APN3	100Yr-18Hr	100	None	25.723	12.100	44.18	(N/A)	(N/A)
APN3 (IN)	100Yr-18Hr	100	None	25.723	12.100	44.18	(N/A)	(N/A)
APN3 (OUT)	100Yr-18Hr	100	None	25.582	15.600	12.51	683.32	15.084
APN4 (IN)	100Yr-18Hr	100	None	8.479	12.100	15.00	(N/A)	(N/A)
APN4 (OUT)	100Yr-18Hr	100	None	8.368	15.800	4.05	686.34	5.116
APN4	100Yr-18Hr	100	None	8.479	12.100	15.00	(N/A)	(N/A)

Scenario Calculation Summary

Executive Summary (Nodes)

Label	Scenario	Return Event (years)	Truncation	Hydrograph Volume (ac-ft)	Time to Peak (hours)	Peak Flow (ft ³ /s)	Maximum Water Surface Elevation (ft)	Maximum Pond Storage (ac-ft)
APN5 (IN)	100Yr-18Hr	100	None	27.994	12.100	38.44	(N/A)	(N/A)
APN5 (OUT)	100Yr-18Hr	100	None	23.782	15.800	13.73	681.09	15.398
APN5	100Yr-18Hr	100	None	19.626	12.100	34.74	(N/A)	(N/A)
APN6 (IN)	100Yr-18Hr	100	None	51.592	12.200	58.36	(N/A)	(N/A)
APN6 (OUT)	100Yr-18Hr	100	None	40.065	18.500	14.24	670.60	26.037
APN6	100Yr-18Hr	100	None	27.810	12.200	51.86	(N/A)	(N/A)
ASH4	100Yr-18Hr	100	None	2.201	12.000	3.91	(N/A)	(N/A)
CLOW CREEK OUTFALL OFF-SITE	100Yr-18Hr	100	None	461.518	14.700	408.61	(N/A)	(N/A)
CREEK OUTFALL 1	100Yr-18Hr	100	None	82.579	17.900	100.11	(N/A)	(N/A)
CREEK OUTFALL 2	100Yr-18Hr	100	None	142.514	0.100	168.35	(N/A)	(N/A)
J-5	100Yr-18Hr	100	None	249.608	13.700	262.57	(N/A)	(N/A)
J-6	100Yr-18Hr	100	None	19.784	12.000	34.81	(N/A)	(N/A)
Offsite Flow (East)	100Yr-18Hr	100	None	0.213	12.000	0.43	(N/A)	(N/A)
Offsite Flow (South)	100Yr-18Hr	100	None	0.341	12.000	0.61	(N/A)	(N/A)
Offsite Flow (West)	100Yr-18Hr	100	None	0.087	12.000	0.17	(N/A)	(N/A)
On-Site Depressional Storage (IN)	100Yr-18Hr	100	None	0.714	12.000	1.29	(N/A)	(N/A)
On-Site Depressional Storage (OUT)	100Yr-18Hr	100	None	0.000	0.000	0.00	651.52	0.714
PR1	100Yr-18Hr	100	None	9.829	12.000	17.28	(N/A)	(N/A)
PR2	100Yr-18Hr	100	None	4.845	12.000	8.52	(N/A)	(N/A)
PR3	100Yr-18Hr	100	None	2.909	12.000	5.11	(N/A)	(N/A)
TAM1 (IN)	100Yr-18Hr	100	None	342.188	13.600	368.45	(N/A)	(N/A)
TAM1 (OUT)	100Yr-18Hr	100	None	341.499	14.100	338.20	664.56	26.288
TAM1	100Yr-18Hr	100	None	66.997	12.100	119.58	(N/A)	(N/A)
TAM2 (IN)	100Yr-18Hr	100	None	43.517	12.700	18.00	(N/A)	(N/A)
TAM2 (OUT)	100Yr-18Hr	100	None	42.402	13.600	17.11	664.34	1.516
TAM2	100Yr-18Hr	100	None	3.452	12.000	5.98	(N/A)	(N/A)
TAM3 (IN)	100Yr-18Hr	100	None	47.517	12.800	25.12	(N/A)	(N/A)

Scenario Calculation Summary

Executive Summary (Nodes)

Label	Scenario	Return Event (years)	Truncation	Hydrograph Volume (ac-ft)	Time to Peak (hours)	Peak Flow (ft ³ /s)	Maximum Water Surface Elevation (ft)	Maximum Pond Storage (ac-ft)
TAM3 (OUT)	100Yr-18Hr	100	None	45.990	13.400	22.54	663.96	2.842
TAM3	100Yr-18Hr	100	None	5.114	12.000	8.93	(N/A)	(N/A)
TAM4 (IN)	100Yr-18Hr	100	None	76.237	12.800	72.27	(N/A)	(N/A)
TAM4 (OUT)	100Yr-18Hr	100	None	70.034	16.900	27.25	663.73	23.905
TAM4	100Yr-18Hr	100	None	30.246	12.100	52.64	(N/A)	(N/A)
TAM5 (IN)	100Yr-18Hr	100	None	74.802	13.600	31.29	(N/A)	(N/A)
TAM5 (OUT)	100Yr-18Hr	100	None	70.843	18.400	27.59	660.06	6.649
TAM5	100Yr-18Hr	100	None	4.768	12.000	8.03	(N/A)	(N/A)
TAM6 (IN)	100Yr-18Hr	100	None	352.110	14.000	350.15	(N/A)	(N/A)
TAM6 (OUT)	100Yr-18Hr	100	None	351.897	14.600	344.01	658.88	7.641
TAM6	100Yr-18Hr	100	None	10.610	12.000	20.06	(N/A)	(N/A)
TAM7 (IN)	100Yr-18Hr	100	None	457.626	14.400	405.40	(N/A)	(N/A)
TAM7 (OUT)	100Yr-18Hr	100	None	453.378	14.700	401.32	655.44	16.369
TAM7	100Yr-18Hr	100	None	34.885	12.100	62.46	(N/A)	(N/A)
West Tributary - Clow Creek (IN)	100Yr-18Hr	100	None	461.590	14.600	408.73	(N/A)	(N/A)
West Tributary - Clow Creek (OUT)	100Yr-18Hr	100	None	461.518	14.700	408.61	650.46	0.293

Executive Summary (Links)

Label	Type	Location	Hydrograph Volume (ac-ft)	Peak Time (hours)	Peak Flow (ft ³ /s)	End Point	Node Flow Direction
APN3 Outlet	Pond Outlet	Upstream	25.723	12.100	44.18	APN3	Pond Inflow
APN3 Outlet	Pond Outlet	Outflow	25.582	15.600	12.51	APN3	Pond Outflow
APN3 Outlet	Pond Outlet	Link	25.582	15.600	12.51		
APN3 Outlet	Pond Outlet	Downstream	342.188	13.600	368.45	TAM1	
APN4 Outlet	Pond Outlet	Upstream	8.479	12.100	15.00	APN4	Pond Inflow
APN4 Outlet	Pond Outlet	Outflow	8.368	15.800	4.05	APN4	Pond Outflow
APN4 Outlet	Pond Outlet	Link	8.368	15.800	4.05		
APN4 Outlet	Pond Outlet	Downstream	27.994	12.100	38.44	APN5	
APN5 Outlet	Pond Outlet	Upstream	27.994	12.100	38.44	APN5	Pond Inflow
APN5 Outlet	Pond Outlet	Outflow	23.782	15.800	13.73	APN5	Pond Outflow

Scenario Calculation Summary

Executive Summary (Links)

Label	Type	Location	Hydrograph Volume (ac-ft)	Peak Time (hours)	Peak Flow (ft ³ /s)	End Point	Node Flow Direction
APN5 Outlet	Pond Outlet	Link	23.782	15.800	13.73		
APN5 Outlet	Pond Outlet	Downstream	51.592	12.200	58.36	APN6	
APN6 Outlet	Pond Outlet	Upstream	51.592	12.200	58.36	APN6	Pond Inflow
APN6 Outlet	Pond Outlet	Outflow	40.065	18.500	14.24	APN6	Pond Outflow
APN6 Outlet	Pond Outlet	Link	39.984	18.500	14.24		
APN6 Outlet	Pond Outlet	Downstream	43.517	12.700	18.00	TAM2	
CO-3	Channel	Upstream	249.608	13.700	262.57	J-5	
CO-3	Channel	Link	249.608	13.800	262.57		
CO-3	Channel	Downstream	342.188	13.600	368.45	TAM1	
CO-4	Channel	Upstream	19.784	12.000	34.81	J-6	
CO-4	Channel	Link	19.784	12.100	34.81		
CO-4	Channel	Downstream	249.608	13.700	262.57	J-5	
OFFSITE FLOW	Pond Outlet	Upstream	461.590	14.600	408.73	West Tributary - Clow Creek	Pond Inflow
OFFSITE FLOW	Pond Outlet	Outflow	461.518	14.700	408.61	West Tributary - Clow Creek	Pond Outflow
OFFSITE FLOW	Pond Outlet	Link	461.518	14.700	408.61		
OFFSITE FLOW	Pond Outlet	Downstream	461.518	14.700	408.61	CLOW CREEK OUTFALL OFF-SITE	
OVERFLOW TO CREEK	Pond Outlet	Upstream	0.714	12.000	1.29	On-Site Depressional Storage	Pond Inflow
OVERFLOW TO CREEK	Pond Outlet	Outflow	0.000	0.000	0.00	On-Site Depressional Storage	Pond Outflow
OVERFLOW TO CREEK	Pond Outlet	Link	0.000	0.000	0.00		
OVERFLOW TO CREEK	Pond Outlet	Downstream	461.590	14.600	408.73	West Tributary - Clow Creek	
TAM1 OUTLET	Pond Outlet	Upstream	342.188	13.600	368.45	TAM1	Pond Inflow
TAM1 OUTLET	Pond Outlet	Outflow	341.499	14.100	338.20	TAM1	Pond Outflow
TAM1 OUTLET	Pond Outlet	Link	341.494	14.100	338.20		
TAM1 OUTLET	Pond Outlet	Downstream	352.110	14.000	350.15	TAM6	
TAM2 Outlet	Pond Outlet	Upstream	43.517	12.700	18.00	TAM2	Pond Inflow
TAM2 Outlet	Pond Outlet	Outflow	42.402	13.600	17.11	TAM2	Pond Outflow
TAM2 Outlet	Pond Outlet	Link	42.402	13.600	17.11		
TAM2 Outlet	Pond Outlet	Downstream	47.517	12.800	25.12	TAM3	

Scenario Calculation Summary

Executive Summary (Links)

Label	Type	Location	Hydrograph Volume (ac-ft)	Peak Time (hours)	Peak Flow (ft ³ /s)	End Point	Node Flow Direction
TAM3 Outlet	Pond Outlet	Upstream	47.517	12.800	25.12	TAM3	Pond Inflow
TAM3 Outlet	Pond Outlet	Outflow	45.990	13.400	22.54	TAM3	Pond Outflow
TAM3 Outlet	Pond Outlet	Link	45.990	13.400	22.54		
TAM3 Outlet	Pond Outlet	Downstream	76.237	12.800	72.27	TAM4	
TAM4 Outlet	Pond Outlet	Upstream	76.237	12.800	72.27	TAM4	Pond Inflow
TAM4 Outlet	Pond Outlet	Outflow	70.034	16.900	27.25	TAM4	Pond Outflow
TAM4 Outlet	Pond Outlet	Link	70.034	16.900	27.25		
TAM4 Outlet	Pond Outlet	Downstream	74.802	13.600	31.29	TAM5	
TAM5 Outlet	Pond Outlet	Upstream	74.802	13.600	31.29	TAM5	Pond Inflow
TAM5 Outlet	Pond Outlet	Outflow	70.843	18.400	27.59	TAM5	Pond Outflow
TAM5 Outlet	Pond Outlet	Link	70.843	18.400	27.59		
TAM5 Outlet	Pond Outlet	Downstream	457.626	14.400	405.40	TAM7	
TAM6	Pond Outlet	Upstream	352.110	14.000	350.15	TAM6	Pond Inflow
TAM6	Pond Outlet	Outflow	351.897	14.600	344.01	TAM6	Pond Outflow
TAM6	Pond Outlet	Link	351.892	14.600	344.01		
TAM6	Pond Outlet	Downstream	457.626	14.400	405.40	TAM7	
TAM7 Outlet	Pond Outlet	Upstream	457.626	14.400	405.40	TAM7	Pond Inflow
TAM7 Outlet	Pond Outlet	Outflow	453.378	14.700	401.32	TAM7	Pond Outflow
TAM7 Outlet	Pond Outlet	Link	453.242	14.700	401.32		
TAM7 Outlet	Pond Outlet	Downstream	461.590	14.600	408.73	West Tributary - Clow Creek	

Messages

Message Id	29
Scenario	2 Yr-24hr
Element Type	Catchment
Element Id	7688
Label	001
Time	(N/A)
Message	Tm > .25Tp. Computation increment, Tm, is greater than 1/4 Time to Peak on Unit Hydrograph. Using a larger Tc can solve this problem.
Source	Warning

Scenario Calculation Summary

Messages

Message Id	67
Scenario	2 Yr-24hr
Element Type	Composite Outlet Structure
Element Id	7699
Label	West Tributary Offsite Flow
Time	(N/A)
Message	Flow direction set to reverse for one ore more structures in composite outlet structure West Tributary Offsite Flow. To eliminate this warning, edit outlet data and select forward only. If reverse flow analysis is required, then the tailwater conditions must be set to interconnected pond.
Source	Warning

Message Id	67
Scenario	2 Yr-18hr
Element Type	Composite Outlet Structure
Element Id	7699
Label	West Tributary Offsite Flow
Time	(N/A)
Message	Flow direction set to reverse for one ore more structures in composite outlet structure West Tributary Offsite Flow. To eliminate this warning, edit outlet data and select forward only. If reverse flow analysis is required, then the tailwater conditions must be set to interconnected pond.
Source	Warning

Message Id	67
Scenario	2 Yr-12hr
Element Type	Composite Outlet Structure
Element Id	7699
Label	West Tributary Offsite Flow
Time	(N/A)
Message	Flow direction set to reverse for one ore more structures in composite outlet structure West Tributary Offsite Flow. To eliminate this warning, edit outlet data and select forward only. If reverse flow analysis is required, then the tailwater conditions must be set to interconnected pond.
Source	Warning

Message Id	67
Scenario	2 Yr-6hr
Element Type	Composite Outlet Structure
Element Id	7699
Label	West Tributary Offsite Flow
Time	(N/A)
Message	Flow direction set to reverse for one ore more structures in composite outlet structure West Tributary Offsite Flow. To eliminate this warning, edit outlet data and select forward only. If reverse flow analysis is required, then the tailwater conditions must be set to interconnected pond.
Source	Warning

Scenario Calculation Summary

Messages

Message Id	67
Scenario	2 Yr-3hr
Element Type	Composite Outlet Structure
Element Id	7699
Label	West Tributary Offsite Flow
Time	(N/A)
Message	Flow direction set to reverse for one ore more structures in composite outlet structure West Tributary Offsite Flow. To eliminate this warning, edit outlet data and select forward only. If reverse flow analysis is required, then the tailwater conditions must be set to interconnected pond.
Source	Warning

Message Id	67
Scenario	2 Yr-2hr
Element Type	Composite Outlet Structure
Element Id	7699
Label	West Tributary Offsite Flow
Time	(N/A)
Message	Flow direction set to reverse for one ore more structures in composite outlet structure West Tributary Offsite Flow. To eliminate this warning, edit outlet data and select forward only. If reverse flow analysis is required, then the tailwater conditions must be set to interconnected pond.
Source	Warning

Message Id	67
Scenario	2 Yr-1hr
Element Type	Composite Outlet Structure
Element Id	7699
Label	West Tributary Offsite Flow
Time	(N/A)
Message	Flow direction set to reverse for one ore more structures in composite outlet structure West Tributary Offsite Flow. To eliminate this warning, edit outlet data and select forward only. If reverse flow analysis is required, then the tailwater conditions must be set to interconnected pond.
Source	Warning

Message Id	39
Scenario	2 Yr-24hr
Element Type	Composite Outlet Structure
Element Id	7697
Label	Depressional Storage Overflow
Time	(N/A)
Message	Reverse flow conditions encountered for one or more headwater elevations. Calculated reverse flows may be approximate.
Source	Warning

Scenario Calculation Summary

Messages

Message Id	39
Scenario	2 Yr-18hr
Element Type	Composite Outlet Structure
Element Id	7697
Label	Depressional Storage Overflow
Time	(N/A)
Message	Reverse flow conditions encountered for one or more headwater elevations. Calculated reverse flows may be approximate.
Source	Warning

Message Id	39
Scenario	2 Yr-12hr
Element Type	Composite Outlet Structure
Element Id	7697
Label	Depressional Storage Overflow
Time	(N/A)
Message	Reverse flow conditions encountered for one or more headwater elevations. Calculated reverse flows may be approximate.
Source	Warning

Message Id	39
Scenario	2 Yr-6hr
Element Type	Composite Outlet Structure
Element Id	7697
Label	Depressional Storage Overflow
Time	(N/A)
Message	Reverse flow conditions encountered for one or more headwater elevations. Calculated reverse flows may be approximate.
Source	Warning

Message Id	39
Scenario	2 Yr-3hr
Element Type	Composite Outlet Structure
Element Id	7697
Label	Depressional Storage Overflow
Time	(N/A)
Message	Reverse flow conditions encountered for one or more headwater elevations. Calculated reverse flows may be approximate.
Source	Warning

Message Id	39
Scenario	2 Yr-2hr
Element Type	Composite Outlet Structure
Element Id	7697
Label	Depressional Storage Overflow
Time	(N/A)
Message	Reverse flow conditions encountered for one or more headwater elevations. Calculated reverse flows may be approximate.
Source	Warning

Scenario Calculation Summary

Messages

Message Id	39
Scenario	2 Yr-1hr
Element Type	Composite Outlet Structure
Element Id	7697
Label	Depressional Storage Overflow
Time	(N/A)
Message	Reverse flow conditions encountered for one or more headwater elevations. Calculated reverse flows may be approximate.
Source	Warning

Message Id	-1
Scenario	2 Yr-24hr
Element Type	Composite Outlet Structure
Element Id	5390
Label	TAM7
Time	(N/A)
Message	A user defined rating table is being used with a non-free outfall tailwater setting. For user defined rating tables it is suggested to use only free outfall tailwater as tailwater effects are not handled.
Source	Precalculation

Scenario Calculation Summary

Scenario Summary			
ID	738		
Label	100 Yr-12Hr		
Notes			
Active Topology	Base Active Topology		
Hydrology	Base Hydrology		
Rainfall Runoff	100Yr-12Hr		
Physical	Base Physical		
Initial Condition	Base Initial Condition		
Boundary Condition	Base Boundary Condition		
Infiltration and Inflow	Base Infiltration and Inflow		
Output	Base Output		
User Data Extensions	Base User Data Extensions		
PondPack Engine Calculation Options	12Hr		
Output Summary			
Output Increment	0.100 hours	Duration	48.000 hours
Rainfall Summary			
Return Event Tag	12 Hr	Rainfall Type	Time-Depth Curve
Total Depth	7.5 in	Storm Event	100YR-12HR
ICPM Output Summary			
Target Convergence	0.00 ft ³ /s	ICPM Time Step	0.100 hours
Maximum Iterations	35		

Executive Summary (Nodes)

Label	Scenario	Return Event (years)	Truncation	Hydrograph Volume (ac-ft)	Time to Peak (hours)	Peak Flow (ft ³ /s)	Maximum Water Surface Elevation (ft)	Maximum Pond Storage (ac-ft)
001	100 Yr-12Hr	100	None	6.335	5.100	16.49	(N/A)	(N/A)
002	100 Yr-12Hr	100	None	0.643	5.000	1.66	(N/A)	(N/A)
003	100 Yr-12Hr	100	None	0.077	5.000	0.20	(N/A)	(N/A)
004	100 Yr-12Hr	100	None	0.307	5.100	0.79	(N/A)	(N/A)
005	100 Yr-12Hr	100	None	0.188	5.000	0.50	(N/A)	(N/A)
101	100 Yr-12Hr	100	None	0.912	5.100	2.40	(N/A)	(N/A)
102	100 Yr-12Hr	100	None	0.039	5.000	0.10	(N/A)	(N/A)
APN2	100 Yr-12Hr	100	None	3.726	5.000	9.79	(N/A)	(N/A)

Scenario Calculation Summary

Executive Summary (Nodes)

Label	Scenario	Return Event (years)	Truncation	Hydrograph Volume (ac-ft)	Time to Peak (hours)	Peak Flow (ft ³ /s)	Maximum Water Surface Elevation (ft)	Maximum Pond Storage (ac-ft)
APN3	100 Yr-12Hr	100	None	23.337	5.100	58.21	(N/A)	(N/A)
APN3 (IN)	100 Yr-12Hr	100	None	23.337	5.100	58.21	(N/A)	(N/A)
APN3 (OUT)	100 Yr-12Hr	100	None	23.239	9.500	12.49	683.30	14.911
APN4 (IN)	100 Yr-12Hr	100	None	7.657	5.200	19.29	(N/A)	(N/A)
APN4 (OUT)	100 Yr-12Hr	100	None	7.584	8.400	4.06	686.22	4.938
APN4	100 Yr-12Hr	100	None	7.657	5.200	19.29	(N/A)	(N/A)
APN5 (IN)	100 Yr-12Hr	100	None	25.302	5.200	48.07	(N/A)	(N/A)
APN5 (OUT)	100 Yr-12Hr	100	None	23.303	12.100	10.25	681.04	15.033
APN5	100 Yr-12Hr	100	None	17.718	5.200	44.53	(N/A)	(N/A)
APN6 (IN)	100 Yr-12Hr	100	None	48.149	5.400	68.50	(N/A)	(N/A)
APN6 (OUT)	100 Yr-12Hr	100	None	39.824	12.600	13.50	670.39	22.227
APN6	100 Yr-12Hr	100	None	24.846	5.300	62.71	(N/A)	(N/A)
ASH4	100 Yr-12Hr	100	None	1.989	5.000	5.12	(N/A)	(N/A)
CLOW CREEK OUTFALL OFF-SITE	100 Yr-12Hr	100	None	411.901	7.600	349.15	(N/A)	(N/A)
CREEK OUTFALL 1	100 Yr-12Hr	100	None	96.028	12.200	82.38	(N/A)	(N/A)
CREEK OUTFALL 2	100 Yr-12Hr	100	None	96.028	12.200	82.38	(N/A)	(N/A)
J-5	100 Yr-12Hr	100	None	214.036	8.000	180.07	(N/A)	(N/A)
J-6	100 Yr-12Hr	100	None	17.898	5.000	45.95	(N/A)	(N/A)
Offsite Flow (East)	100 Yr-12Hr	100	None	0.188	5.000	0.50	(N/A)	(N/A)
Offsite Flow (South)	100 Yr-12Hr	100	None	0.307	5.100	0.79	(N/A)	(N/A)
Offsite Flow (West)	100 Yr-12Hr	100	None	0.077	5.000	0.20	(N/A)	(N/A)

Scenario Calculation Summary

Executive Summary (Nodes)

Label	Scenario	Return Event (years)	Truncation	Hydrograph Volume (ac-ft)	Time to Peak (hours)	Peak Flow (ft ³ /s)	Maximum Water Surface Elevation (ft)	Maximum Pond Storage (ac-ft)
On-Site Depressional Storage (IN)	100 Yr-12Hr	100	None	0.643	5.000	1.66	(N/A)	(N/A)
On-Site Depressional Storage (OUT)	100 Yr-12Hr	100	None	0.000	0.000	0.00	651.46	0.643
PR1	100 Yr-12Hr	100	None	8.894	5.000	22.82	(N/A)	(N/A)
PR2	100 Yr-12Hr	100	None	4.384	5.000	11.25	(N/A)	(N/A)
PR3	100 Yr-12Hr	100	None	2.632	5.000	6.75	(N/A)	(N/A)
TAM1 (IN)	100 Yr-12Hr	100	None	297.698	6.200	280.33	(N/A)	(N/A)
TAM1 (OUT)	100 Yr-12Hr	100	None	297.190	7.900	261.91	663.76	20.951
TAM1	100 Yr-12Hr	100	None	60.423	5.100	153.66	(N/A)	(N/A)
TAM2 (IN)	100 Yr-12Hr	100	None	42.954	7.000	16.75	(N/A)	(N/A)
TAM2 (OUT)	100 Yr-12Hr	100	None	42.032	7.600	16.13	664.26	1.447
TAM2	100 Yr-12Hr	100	None	3.130	5.000	7.99	(N/A)	(N/A)
TAM3 (IN)	100 Yr-12Hr	100	None	46.664	6.100	23.82	(N/A)	(N/A)
TAM3 (OUT)	100 Yr-12Hr	100	None	45.496	7.400	21.00	663.79	2.605
TAM3	100 Yr-12Hr	100	None	4.631	5.000	11.78	(N/A)	(N/A)
TAM4 (IN)	100 Yr-12Hr	100	None	72.867	5.600	80.10	(N/A)	(N/A)
TAM4 (OUT)	100 Yr-12Hr	100	None	69.051	11.300	26.34	663.57	22.170
TAM4	100 Yr-12Hr	100	None	27.370	5.200	67.69	(N/A)	(N/A)
TAM5 (IN)	100 Yr-12Hr	100	None	73.390	6.100	30.13	(N/A)	(N/A)
TAM5 (OUT)	100 Yr-12Hr	100	None	70.665	12.400	26.85	660.00	6.277
TAM5	100 Yr-12Hr	100	None	4.339	5.100	10.79	(N/A)	(N/A)
TAM6 (IN)	100 Yr-12Hr	100	None	306.661	7.000	274.02	(N/A)	(N/A)

Scenario Calculation Summary

Executive Summary (Nodes)

Label	Scenario	Return Event (years)	Truncation	Hydrograph Volume (ac-ft)	Time to Peak (hours)	Peak Flow (ft ³ /s)	Maximum Water Surface Elevation (ft)	Maximum Pond Storage (ac-ft)
TAM6 (OUT)	100 Yr-12Hr	100	None	306.458	8.000	272.37	658.14	5.126
TAM6	100 Yr-12Hr	100	None	9.472	5.100	24.72	(N/A)	(N/A)
TAM7 (IN)	100 Yr-12Hr	100	None	408.547	6.800	340.53	(N/A)	(N/A)
TAM7 (OUT)	100 Yr-12Hr	100	None	404.666	7.600	337.90	654.96	14.620
TAM7	100 Yr-12Hr	100	None	31.424	5.200	78.90	(N/A)	(N/A)
West Tributary - Clow Creek (IN)	100 Yr-12Hr	100	None	411.952	7.500	349.24	(N/A)	(N/A)
West Tributary - Clow Creek (OUT)	100 Yr-12Hr	100	None	411.901	7.600	349.15	650.17	0.215

Executive Summary (Links)

Label	Type	Location	Hydrograph Volume (ac-ft)	Peak Time (hours)	Peak Flow (ft ³ /s)	End Point	Node Flow Direction
APN3 Outlet	Pond Outlet	Upstream	23.337	5.100	58.21	APN3	Pond Inflow
APN3 Outlet	Pond Outlet	Outflow	23.239	9.500	12.49	APN3	Pond Outflow
APN3 Outlet	Pond Outlet	Link	23.239	9.500	12.49		
APN3 Outlet	Pond Outlet	Downstream	297.698	6.200	280.33	TAM1	
APN4 Outlet	Pond Outlet	Upstream	7.657	5.200	19.29	APN4	Pond Inflow
APN4 Outlet	Pond Outlet	Outflow	7.584	8.400	4.06	APN4	Pond Outflow
APN4 Outlet	Pond Outlet	Link	7.584	8.400	4.06		
APN4 Outlet	Pond Outlet	Downstream	25.302	5.200	48.07	APN5	
APN5 Outlet	Pond Outlet	Upstream	25.302	5.200	48.07	APN5	Pond Inflow
APN5 Outlet	Pond Outlet	Outflow	23.303	12.100	10.25	APN5	Pond Outflow
APN5 Outlet	Pond Outlet	Link	23.303	12.100	10.25		
APN5 Outlet	Pond Outlet	Downstream	48.149	5.400	68.50	APN6	
APN6 Outlet	Pond Outlet	Upstream	48.149	5.400	68.50	APN6	Pond Inflow
APN6 Outlet	Pond Outlet	Outflow	39.824	12.600	13.50	APN6	Pond Outflow
APN6 Outlet	Pond Outlet	Link	39.767	12.600	13.50		
APN6 Outlet	Pond Outlet	Downstream	42.954	7.000	16.75	TAM2	
CO-3	Channel	Upstream	214.036	8.000	180.07	J-5	
CO-3	Channel	Link	214.036	8.100	180.07		

Scenario Calculation Summary

Executive Summary (Links)

Label	Type	Location	Hydrograph Volume (ac-ft)	Peak Time (hours)	Peak Flow (ft ³ /s)	End Point	Node Flow Direction
CO-3	Channel	Downstream	297.698	6.200	280.33	TAM1	
CO-4	Channel	Upstream	17.898	5.000	45.95	J-6	
CO-4	Channel	Link	17.898	5.100	45.95		
CO-4	Channel	Downstream	214.036	8.000	180.07	J-5	
OFFSITE FLOW	Pond Outlet	Upstream	411.952	7.500	349.24	West Tributary - Clow Creek	Pond Inflow
OFFSITE FLOW	Pond Outlet	Outflow	411.901	7.600	349.15	West Tributary - Clow Creek	Pond Outflow
OFFSITE FLOW	Pond Outlet	Link	411.901	7.600	349.15		
OFFSITE FLOW	Pond Outlet	Downstream	411.901	7.600	349.15	CLOW CREEK OUTFALL OFF-SITE	
OVERFLOW TO CREEK	Pond Outlet	Upstream	0.643	5.000	1.66	On-Site Depressional Storage	Pond Inflow
OVERFLOW TO CREEK	Pond Outlet	Outflow	0.000	0.000	0.00	On-Site Depressional Storage	Pond Outflow
OVERFLOW TO CREEK	Pond Outlet	Link	0.000	0.000	0.00		
OVERFLOW TO CREEK	Pond Outlet	Downstream	411.952	7.500	349.24	West Tributary - Clow Creek	
TAM1 OUTLET	Pond Outlet	Upstream	297.698	6.200	280.33	TAM1	Pond Inflow
TAM1 OUTLET	Pond Outlet	Outflow	297.190	7.900	261.91	TAM1	Pond Outflow
TAM1 OUTLET	Pond Outlet	Link	297.190	7.900	261.91		
TAM1 OUTLET	Pond Outlet	Downstream	306.661	7.000	274.02	TAM6	
TAM2 Outlet	Pond Outlet	Upstream	42.954	7.000	16.75	TAM2	Pond Inflow
TAM2 Outlet	Pond Outlet	Outflow	42.032	7.600	16.13	TAM2	Pond Outflow
TAM2 Outlet	Pond Outlet	Link	42.032	7.600	16.13		
TAM2 Outlet	Pond Outlet	Downstream	46.664	6.100	23.82	TAM3	
TAM3 Outlet	Pond Outlet	Upstream	46.664	6.100	23.82	TAM3	Pond Inflow
TAM3 Outlet	Pond Outlet	Outflow	45.496	7.400	21.00	TAM3	Pond Outflow
TAM3 Outlet	Pond Outlet	Link	45.435	7.400	21.00		
TAM3 Outlet	Pond Outlet	Downstream	72.867	5.600	80.10	TAM4	
TAM4 Outlet	Pond Outlet	Upstream	72.867	5.600	80.10	TAM4	Pond Inflow
TAM4 Outlet	Pond Outlet	Outflow	69.051	11.300	26.34	TAM4	Pond Outflow
TAM4 Outlet	Pond Outlet	Link	69.051	11.300	26.34		

Scenario Calculation Summary

Executive Summary (Links)

Label	Type	Location	Hydrograph Volume (ac-ft)	Peak Time (hours)	Peak Flow (ft ³ /s)	End Point	Node Flow Direction
TAM4 Outlet	Pond Outlet	Downstream	73.390	6.100	30.13	TAM5	
TAM5 Outlet	Pond Outlet	Upstream	73.390	6.100	30.13	TAM5	Pond Inflow
TAM5 Outlet	Pond Outlet	Outflow	70.665	12.400	26.85	TAM5	Pond Outflow
TAM5 Outlet	Pond Outlet	Link	70.665	12.400	26.85		
TAM5 Outlet	Pond Outlet	Downstream	408.547	6.800	340.53	TAM7	
TAM6	Pond Outlet	Upstream	306.661	7.000	274.02	TAM6	Pond Inflow
TAM6	Pond Outlet	Outflow	306.458	8.000	272.37	TAM6	Pond Outflow
TAM6	Pond Outlet	Link	306.455	8.000	272.37		
TAM6	Pond Outlet	Downstream	408.547	6.800	340.53	TAM7	
TAM7 Outlet	Pond Outlet	Upstream	408.547	6.800	340.53	TAM7	Pond Inflow
TAM7 Outlet	Pond Outlet	Outflow	404.666	7.600	337.90	TAM7	Pond Outflow
TAM7 Outlet	Pond Outlet	Link	404.666	7.600	337.90		
TAM7 Outlet	Pond Outlet	Downstream	411.952	7.500	349.24	West Tributary - Clow Creek	

Messages

Message Id	29
Scenario	2 Yr-24hr
Element Type	Catchment
Element Id	7688
Label	001
Time	(N/A)
Message	Tm > .25Tp. Computation increment, Tm, is greater than 1/4 Time to Peak on Unit Hydrograph. Using a larger Tc can solve this problem.
Source	Warning
Message Id	67
Scenario	2 Yr-24hr
Element Type	Composite Outlet Structure
Element Id	7699
Label	West Tributary Offsite Flow
Time	(N/A)
Message	Flow direction set to reverse for one ore more structures in composite outlet structure West Tributary Offsite Flow. To eliminate this warning, edit outlet data and select forward only. If reverse flow analysis is required, then the tailwater conditions must be set to interconnected pond.
Source	Warning

Scenario Calculation Summary

Messages

Message Id	67
Scenario	2 Yr-18hr
Element Type	Composite Outlet Structure
Element Id	7699
Label	West Tributary Offsite Flow
Time	(N/A)
Message	Flow direction set to reverse for one ore more structures in composite outlet structure West Tributary Offsite Flow. To eliminate this warning, edit outlet data and select forward only. If reverse flow analysis is required, then the tailwater conditions must be set to interconnected pond.
Source	Warning

Message Id	67
Scenario	2 Yr-12hr
Element Type	Composite Outlet Structure
Element Id	7699
Label	West Tributary Offsite Flow
Time	(N/A)
Message	Flow direction set to reverse for one ore more structures in composite outlet structure West Tributary Offsite Flow. To eliminate this warning, edit outlet data and select forward only. If reverse flow analysis is required, then the tailwater conditions must be set to interconnected pond.
Source	Warning

Message Id	67
Scenario	2 Yr-6hr
Element Type	Composite Outlet Structure
Element Id	7699
Label	West Tributary Offsite Flow
Time	(N/A)
Message	Flow direction set to reverse for one ore more structures in composite outlet structure West Tributary Offsite Flow. To eliminate this warning, edit outlet data and select forward only. If reverse flow analysis is required, then the tailwater conditions must be set to interconnected pond.
Source	Warning

Message Id	67
Scenario	2 Yr-3hr
Element Type	Composite Outlet Structure
Element Id	7699
Label	West Tributary Offsite Flow
Time	(N/A)
Message	Flow direction set to reverse for one ore more structures in composite outlet structure West Tributary Offsite Flow. To eliminate this warning, edit outlet data and select forward only. If reverse flow analysis is required, then the tailwater conditions must be set to interconnected pond.
Source	Warning

Scenario Calculation Summary

Messages

Message Id	67
Scenario	2 Yr-2hr
Element Type	Composite Outlet Structure
Element Id	7699
Label	West Tributary Offsite Flow
Time	(N/A)
Message	Flow direction set to reverse for one ore more structures in composite outlet structure West Tributary Offsite Flow. To eliminate this warning, edit outlet data and select forward only. If reverse flow analysis is required, then the tailwater conditions must be set to interconnected pond.
Source	Warning
Message Id	67
Scenario	2 Yr-1hr
Element Type	Composite Outlet Structure
Element Id	7699
Label	West Tributary Offsite Flow
Time	(N/A)
Message	Flow direction set to reverse for one ore more structures in composite outlet structure West Tributary Offsite Flow. To eliminate this warning, edit outlet data and select forward only. If reverse flow analysis is required, then the tailwater conditions must be set to interconnected pond.
Source	Warning
Message Id	39
Scenario	2 Yr-24hr
Element Type	Composite Outlet Structure
Element Id	7697
Label	Depressional Storage Overflow
Time	(N/A)
Message	Reverse flow conditions encountered for one or more headwater elevations. Calculated reverse flows may be approximate.
Source	Warning
Message Id	39
Scenario	2 Yr-18hr
Element Type	Composite Outlet Structure
Element Id	7697
Label	Depressional Storage Overflow
Time	(N/A)
Message	Reverse flow conditions encountered for one or more headwater elevations. Calculated reverse flows may be approximate.
Source	Warning
Message Id	39
Scenario	2 Yr-12hr
Element Type	Composite Outlet Structure
Element Id	7697
Label	Depressional Storage Overflow
Time	(N/A)
Message	Reverse flow conditions encountered for one or more headwater elevations. Calculated reverse flows may be approximate.
Source	Warning

Scenario Calculation Summary

Messages

Message Id	39
Scenario	2 Yr-6hr
Element Type	Composite Outlet Structure
Element Id	7697
Label	Depressional Storage Overflow
Time	(N/A)
Message	Reverse flow conditions encountered for one or more headwater elevations. Calculated reverse flows may be approximate.
Source	Warning
Message Id	39
Scenario	2 Yr-3hr
Element Type	Composite Outlet Structure
Element Id	7697
Label	Depressional Storage Overflow
Time	(N/A)
Message	Reverse flow conditions encountered for one or more headwater elevations. Calculated reverse flows may be approximate.
Source	Warning
Message Id	39
Scenario	2 Yr-2hr
Element Type	Composite Outlet Structure
Element Id	7697
Label	Depressional Storage Overflow
Time	(N/A)
Message	Reverse flow conditions encountered for one or more headwater elevations. Calculated reverse flows may be approximate.
Source	Warning
Message Id	39
Scenario	2 Yr-1hr
Element Type	Composite Outlet Structure
Element Id	7697
Label	Depressional Storage Overflow
Time	(N/A)
Message	Reverse flow conditions encountered for one or more headwater elevations. Calculated reverse flows may be approximate.
Source	Warning
Message Id	-1
Scenario	2 Yr-24hr
Element Type	Composite Outlet Structure
Element Id	5390
Label	TAM7
Time	(N/A)
Message	A user defined rating table is being used with a non-free outfall tailwater setting. For user defined rating tables it is suggested to use only free outfall tailwater as tailwater effects are not handled.
Source	Precalculation

Scenario Calculation Summary

Scenario Summary			
ID	1718		
Label	100Yr-6Hr		
Notes			
Active Topology	<I> Base Active Topology		
Hydrology	<I> Base Hydrology		
Rainfall Runoff	100Yr-6Hr		
Physical	<I> Base Physical		
Initial Condition	<I> Base Initial Condition		
Boundary Condition	<I> Base Boundary Condition		
Infiltration and Inflow	<I> Base Infiltration and Inflow		
Output	<I> Base Output		
User Data Extensions	<I> Base User Data Extensions		
PondPack Engine Calculation Options	<I> 12Hr		
Output Summary			
Output Increment	0.100 hours	Duration	48.000 hours
Rainfall Summary			
Return Event Tag	12 Hr	Rainfall Type	Time-Depth Curve
Total Depth	6.4 in	Storm Event	100YR- 6HR
ICPM Output Summary			
Target Convergence	0.00 ft ³ /s	ICPM Time Step	0.100 hours
Maximum Iterations	35		

Executive Summary (Nodes)

Label	Scenario	Return Event (years)	Truncation	Hydrograph Volume (ac-ft)	Time to Peak (hours)	Peak Flow (ft ³ /s)	Maximum Water Surface Elevation (ft)	Maximum Pond Storage (ac-ft)
001	100Yr-6Hr	100	None	5.000	1.600	23.23	(N/A)	(N/A)
002	100Yr-6Hr	100	None	0.523	1.400	2.52	(N/A)	(N/A)
003	100Yr-6Hr	100	None	0.060	1.500	0.29	(N/A)	(N/A)
004	100Yr-6Hr	100	None	0.250	1.400	1.20	(N/A)	(N/A)
005	100Yr-6Hr	100	None	0.145	1.500	0.69	(N/A)	(N/A)
101	100Yr-6Hr	100	None	0.710	1.500	3.32	(N/A)	(N/A)
102	100Yr-6Hr	100	None	0.030	1.500	0.14	(N/A)	(N/A)
APN2	100Yr-6Hr	100	None	2.971	1.500	14.13	(N/A)	(N/A)
APN3	100Yr-6Hr	100	None	19.275	1.500	91.35	(N/A)	(N/A)
APN3 (IN)	100Yr-6Hr	100	None	19.275	1.500	91.35	(N/A)	(N/A)
APN3 (OUT)	100Yr-6Hr	100	None	19.201	6.200	12.37	683.19	13.762
APN4 (IN)	100Yr-6Hr	100	None	6.263	1.600	29.29	(N/A)	(N/A)
APN4 (OUT)	100Yr-6Hr	100	None	6.211	5.400	4.00	685.89	4.497
APN4	100Yr-6Hr	100	None	6.263	1.600	29.29	(N/A)	(N/A)

Scenario Calculation Summary

Executive Summary (Nodes)

Label	Scenario	Return Event (years)	Truncation	Hydrograph Volume (ac-ft)	Time to Peak (hours)	Peak Flow (ft ³ /s)	Maximum Water Surface Elevation (ft)	Maximum Pond Storage (ac-ft)
APN5 (IN)	100Yr-6Hr	100	None	20.694	1.600	70.61	(N/A)	(N/A)
APN5 (OUT)	100Yr-6Hr	100	None	20.465	6.600	6.94	680.80	13.223
APN5	100Yr-6Hr	100	None	14.484	1.600	67.14	(N/A)	(N/A)
APN6 (IN)	100Yr-6Hr	100	None	40.331	1.800	93.47	(N/A)	(N/A)
APN6 (OUT)	100Yr-6Hr	100	None	34.770	6.600	12.65	670.16	18.053
APN6	100Yr-6Hr	100	None	19.866	1.800	88.31	(N/A)	(N/A)
ASH4	100Yr-6Hr	100	None	1.628	1.300	7.96	(N/A)	(N/A)
CLOW CREEK OUTFALL OFF-SITE	100Yr-6Hr	100	None	415.473	3.800	419.29	(N/A)	(N/A)
CREEK OUTFALL 1	100Yr-6Hr	100	None	81.117	6.200	65.58	(N/A)	(N/A)
CREEK OUTFALL 2	100Yr-6Hr	100	None	151.767	0.100	168.35	(N/A)	(N/A)
J-5	100Yr-6Hr	100	None	250.835	1.900	237.19	(N/A)	(N/A)
J-6	100Yr-6Hr	100	None	14.693	1.300	71.99	(N/A)	(N/A)
Offsite Flow (East)	100Yr-6Hr	100	None	0.145	1.500	0.69	(N/A)	(N/A)
Offsite Flow (South)	100Yr-6Hr	100	None	0.250	1.400	1.20	(N/A)	(N/A)
Offsite Flow (West)	100Yr-6Hr	100	None	0.060	1.500	0.29	(N/A)	(N/A)
On-Site Depressional Storage (IN)	100Yr-6Hr	100	None	0.523	1.400	2.52	(N/A)	(N/A)
On-Site Depressional Storage (OUT)	100Yr-6Hr	100	None	0.000	0.000	0.00	651.37	0.523
PR1	100Yr-6Hr	100	None	7.304	1.300	35.79	(N/A)	(N/A)
PR2	100Yr-6Hr	100	None	3.600	1.300	17.64	(N/A)	(N/A)
PR3	100Yr-6Hr	100	None	2.161	1.300	10.59	(N/A)	(N/A)
TAM1 (IN)	100Yr-6Hr	100	None	319.320	1.800	456.87	(N/A)	(N/A)
TAM1 (OUT)	100Yr-6Hr	100	None	318.891	2.700	344.16	664.62	26.732
TAM1	100Yr-6Hr	100	None	49.284	1.500	232.69	(N/A)	(N/A)
TAM2 (IN)	100Yr-6Hr	100	None	37.352	3.600	15.33	(N/A)	(N/A)
TAM2 (OUT)	100Yr-6Hr	100	None	36.622	4.500	14.72	664.17	1.356
TAM2	100Yr-6Hr	100	None	2.582	1.100	12.79	(N/A)	(N/A)
TAM3 (IN)	100Yr-6Hr	100	None	40.432	1.700	24.55	(N/A)	(N/A)

Scenario Calculation Summary

Executive Summary (Nodes)

Label	Scenario	Return Event (years)	Truncation	Hydrograph Volume (ac-ft)	Time to Peak (hours)	Peak Flow (ft ³ /s)	Maximum Water Surface Elevation (ft)	Maximum Pond Storage (ac-ft)
TAM3 (OUT)	100Yr-6Hr	100	None	39.607	4.200	18.81	663.58	2.313
TAM3	100Yr-6Hr	100	None	3.810	1.300	18.59	(N/A)	(N/A)
TAM4 (IN)	100Yr-6Hr	100	None	62.091	1.700	111.58	(N/A)	(N/A)
TAM4 (OUT)	100Yr-6Hr	100	None	59.062	6.500	24.98	663.35	19.708
TAM4	100Yr-6Hr	100	None	22.485	1.700	102.25	(N/A)	(N/A)
TAM5 (IN)	100Yr-6Hr	100	None	62.670	1.700	30.63	(N/A)	(N/A)
TAM5 (OUT)	100Yr-6Hr	100	None	60.995	8.500	24.14	659.80	5.687
TAM5	100Yr-6Hr	100	None	3.607	1.300	17.62	(N/A)	(N/A)
TAM6 (IN)	100Yr-6Hr	100	None	326.451	2.600	361.27	(N/A)	(N/A)
TAM6 (OUT)	100Yr-6Hr	100	None	326.253	3.500	349.22	658.94	7.816
TAM6	100Yr-6Hr	100	None	7.560	1.500	35.67	(N/A)	(N/A)
TAM7 (IN)	100Yr-6Hr	100	None	412.813	3.300	413.15	(N/A)	(N/A)
TAM7 (OUT)	100Yr-6Hr	100	None	409.769	3.800	408.85	655.49	16.569
TAM7	100Yr-6Hr	100	None	25.566	1.700	116.72	(N/A)	(N/A)
West Tributary - Clow Creek (IN)	100Yr-6Hr	100	None	415.508	3.700	419.41	(N/A)	(N/A)
West Tributary - Clow Creek (OUT)	100Yr-6Hr	100	None	415.473	3.800	419.29	650.51	0.307

Executive Summary (Links)

Label	Type	Location	Hydrograph Volume (ac-ft)	Peak Time (hours)	Peak Flow (ft ³ /s)	End Point	Node Flow Direction
APN3 Outlet	Pond Outlet	Upstream	19.275	1.500	91.35	APN3	Pond Inflow
APN3 Outlet	Pond Outlet	Outflow	19.201	6.200	12.37	APN3	Pond Outflow
APN3 Outlet	Pond Outlet	Link	19.200	6.200	12.37		
APN3 Outlet	Pond Outlet	Downstream	319.320	1.800	456.87	TAM1	
APN4 Outlet	Pond Outlet	Upstream	6.263	1.600	29.29	APN4	Pond Inflow
APN4 Outlet	Pond Outlet	Outflow	6.211	5.400	4.00	APN4	Pond Outflow
APN4 Outlet	Pond Outlet	Link	6.211	5.400	4.00		
APN4 Outlet	Pond Outlet	Downstream	20.694	1.600	70.61	APN5	
APN5 Outlet	Pond Outlet	Upstream	20.694	1.600	70.61	APN5	Pond Inflow
APN5 Outlet	Pond Outlet	Outflow	20.465	6.600	6.94	APN5	Pond Outflow

Scenario Calculation Summary

Executive Summary (Links)

Label	Type	Location	Hydrograph Volume (ac-ft)	Peak Time (hours)	Peak Flow (ft ³ /s)	End Point	Node Flow Direction
APN5 Outlet	Pond Outlet	Link	20.465	6.600	6.94		
APN5 Outlet	Pond Outlet	Downstream	40.331	1.800	93.47	APN6	
APN6 Outlet	Pond Outlet	Upstream	40.331	1.800	93.47	APN6	Pond Inflow
APN6 Outlet	Pond Outlet	Outflow	34.770	6.600	12.65	APN6	Pond Outflow
APN6 Outlet	Pond Outlet	Link	34.770	6.600	12.65		
APN6 Outlet	Pond Outlet	Downstream	37.352	3.600	15.33	TAM2	
CO-3	Channel	Upstream	250.835	1.900	237.19	J-5	
CO-3	Channel	Link	250.835	2.000	237.19		
CO-3	Channel	Downstream	319.320	1.800	456.87	TAM1	
CO-4	Channel	Upstream	14.693	1.300	71.99	J-6	
CO-4	Channel	Link	14.693	1.400	71.99		
CO-4	Channel	Downstream	250.835	1.900	237.19	J-5	
OFFSITE FLOW	Pond Outlet	Upstream	415.508	3.700	419.41	West Tributary - Clow Creek	Pond Inflow
OFFSITE FLOW	Pond Outlet	Outflow	415.473	3.800	419.29	West Tributary - Clow Creek	Pond Outflow
OFFSITE FLOW	Pond Outlet	Link	415.473	3.800	419.29		
OFFSITE FLOW	Pond Outlet	Downstream	415.473	3.800	419.29	CLOW CREEK OUTFALL OFF-SITE	
OVERFLOW TO CREEK	Pond Outlet	Upstream	0.523	1.400	2.52	On-Site Depressional Storage	Pond Inflow
OVERFLOW TO CREEK	Pond Outlet	Outflow	0.000	0.000	0.00	On-Site Depressional Storage	Pond Outflow
OVERFLOW TO CREEK	Pond Outlet	Link	0.000	0.000	0.00		
OVERFLOW TO CREEK	Pond Outlet	Downstream	415.508	3.700	419.41	West Tributary - Clow Creek	
TAM1 OUTLET	Pond Outlet	Upstream	319.320	1.800	456.87	TAM1	Pond Inflow
TAM1 OUTLET	Pond Outlet	Outflow	318.891	2.700	344.16	TAM1	Pond Outflow
TAM1 OUTLET	Pond Outlet	Link	318.889	2.700	344.16		
TAM1 OUTLET	Pond Outlet	Downstream	326.451	2.600	361.27	TAM6	
TAM2 Outlet	Pond Outlet	Upstream	37.352	3.600	15.33	TAM2	Pond Inflow
TAM2 Outlet	Pond Outlet	Outflow	36.622	4.500	14.72	TAM2	Pond Outflow
TAM2 Outlet	Pond Outlet	Link	36.584	4.500	14.72		
TAM2 Outlet	Pond Outlet	Downstream	40.432	1.700	24.55	TAM3	

Scenario Calculation Summary

Executive Summary (Links)

Label	Type	Location	Hydrograph Volume (ac-ft)	Peak Time (hours)	Peak Flow (ft ³ /s)	End Point	Node Flow Direction
TAM3 Outlet	Pond Outlet	Upstream	40.432	1.700	24.55	TAM3	Pond Inflow
TAM3 Outlet	Pond Outlet	Outflow	39.607	4.200	18.81	TAM3	Pond Outflow
TAM3 Outlet	Pond Outlet	Link	39.565	4.200	18.81		
TAM3 Outlet	Pond Outlet	Downstream	62.091	1.700	111.58	TAM4	
TAM4 Outlet	Pond Outlet	Upstream	62.091	1.700	111.58	TAM4	Pond Inflow
TAM4 Outlet	Pond Outlet	Outflow	59.062	6.500	24.98	TAM4	Pond Outflow
TAM4 Outlet	Pond Outlet	Link	59.062	6.500	24.98		
TAM4 Outlet	Pond Outlet	Downstream	62.670	1.700	30.63	TAM5	
TAM5 Outlet	Pond Outlet	Upstream	62.670	1.700	30.63	TAM5	Pond Inflow
TAM5 Outlet	Pond Outlet	Outflow	60.995	8.500	24.14	TAM5	Pond Outflow
TAM5 Outlet	Pond Outlet	Link	60.995	8.500	24.14		
TAM5 Outlet	Pond Outlet	Downstream	412.813	3.300	413.15	TAM7	
TAM6	Pond Outlet	Upstream	326.451	2.600	361.27	TAM6	Pond Inflow
TAM6	Pond Outlet	Outflow	326.253	3.500	349.22	TAM6	Pond Outflow
TAM6	Pond Outlet	Link	326.253	3.500	349.22		
TAM6	Pond Outlet	Downstream	412.813	3.300	413.15	TAM7	
TAM7 Outlet	Pond Outlet	Upstream	412.813	3.300	413.15	TAM7	Pond Inflow
TAM7 Outlet	Pond Outlet	Outflow	409.769	3.800	408.85	TAM7	Pond Outflow
TAM7 Outlet	Pond Outlet	Link	409.702	3.800	408.85		
TAM7 Outlet	Pond Outlet	Downstream	415.508	3.700	419.41	West Tributary - Clow Creek	

Messages

Message Id	29
Scenario	2 Yr-24hr
Element Type	Catchment
Element Id	7688
Label	001
Time	(N/A)
Message	Tm > .25Tp. Computation increment, Tm, is greater than 1/4 Time to Peak on Unit Hydrograph. Using a larger Tc can solve this problem.
Source	Warning

Scenario Calculation Summary

Messages

Message Id	67
Scenario	2 Yr-24hr
Element Type	Composite Outlet Structure
Element Id	7699
Label	West Tributary Offsite Flow
Time	(N/A)
Message	Flow direction set to reverse for one ore more structures in composite outlet structure West Tributary Offsite Flow. To eliminate this warning, edit outlet data and select forward only. If reverse flow analysis is required, then the tailwater conditions must be set to interconnected pond.
Source	Warning

Message Id	67
Scenario	2 Yr-18hr
Element Type	Composite Outlet Structure
Element Id	7699
Label	West Tributary Offsite Flow
Time	(N/A)
Message	Flow direction set to reverse for one ore more structures in composite outlet structure West Tributary Offsite Flow. To eliminate this warning, edit outlet data and select forward only. If reverse flow analysis is required, then the tailwater conditions must be set to interconnected pond.
Source	Warning

Message Id	67
Scenario	2 Yr-12hr
Element Type	Composite Outlet Structure
Element Id	7699
Label	West Tributary Offsite Flow
Time	(N/A)
Message	Flow direction set to reverse for one ore more structures in composite outlet structure West Tributary Offsite Flow. To eliminate this warning, edit outlet data and select forward only. If reverse flow analysis is required, then the tailwater conditions must be set to interconnected pond.
Source	Warning

Message Id	67
Scenario	2 Yr-6hr
Element Type	Composite Outlet Structure
Element Id	7699
Label	West Tributary Offsite Flow
Time	(N/A)
Message	Flow direction set to reverse for one ore more structures in composite outlet structure West Tributary Offsite Flow. To eliminate this warning, edit outlet data and select forward only. If reverse flow analysis is required, then the tailwater conditions must be set to interconnected pond.
Source	Warning

Scenario Calculation Summary

Messages

Message Id	67
Scenario	2 Yr-3hr
Element Type	Composite Outlet Structure
Element Id	7699
Label	West Tributary Offsite Flow
Time	(N/A)
Message	Flow direction set to reverse for one ore more structures in composite outlet structure West Tributary Offsite Flow. To eliminate this warning, edit outlet data and select forward only. If reverse flow analysis is required, then the tailwater conditions must be set to interconnected pond.
Source	Warning

Message Id	67
Scenario	2 Yr-2hr
Element Type	Composite Outlet Structure
Element Id	7699
Label	West Tributary Offsite Flow
Time	(N/A)
Message	Flow direction set to reverse for one ore more structures in composite outlet structure West Tributary Offsite Flow. To eliminate this warning, edit outlet data and select forward only. If reverse flow analysis is required, then the tailwater conditions must be set to interconnected pond.
Source	Warning

Message Id	67
Scenario	2 Yr-1hr
Element Type	Composite Outlet Structure
Element Id	7699
Label	West Tributary Offsite Flow
Time	(N/A)
Message	Flow direction set to reverse for one ore more structures in composite outlet structure West Tributary Offsite Flow. To eliminate this warning, edit outlet data and select forward only. If reverse flow analysis is required, then the tailwater conditions must be set to interconnected pond.
Source	Warning

Message Id	39
Scenario	2 Yr-24hr
Element Type	Composite Outlet Structure
Element Id	7697
Label	Depressional Storage Overflow
Time	(N/A)
Message	Reverse flow conditions encountered for one or more headwater elevations. Calculated reverse flows may be approximate.
Source	Warning

Scenario Calculation Summary

Messages

Message Id	39
Scenario	2 Yr-18hr
Element Type	Composite Outlet Structure
Element Id	7697
Label	Depressional Storage Overflow
Time	(N/A)
Message	Reverse flow conditions encountered for one or more headwater elevations. Calculated reverse flows may be approximate.
Source	Warning

Message Id	39
Scenario	2 Yr-12hr
Element Type	Composite Outlet Structure
Element Id	7697
Label	Depressional Storage Overflow
Time	(N/A)
Message	Reverse flow conditions encountered for one or more headwater elevations. Calculated reverse flows may be approximate.
Source	Warning

Message Id	39
Scenario	2 Yr-6hr
Element Type	Composite Outlet Structure
Element Id	7697
Label	Depressional Storage Overflow
Time	(N/A)
Message	Reverse flow conditions encountered for one or more headwater elevations. Calculated reverse flows may be approximate.
Source	Warning

Message Id	39
Scenario	2 Yr-3hr
Element Type	Composite Outlet Structure
Element Id	7697
Label	Depressional Storage Overflow
Time	(N/A)
Message	Reverse flow conditions encountered for one or more headwater elevations. Calculated reverse flows may be approximate.
Source	Warning

Message Id	39
Scenario	2 Yr-2hr
Element Type	Composite Outlet Structure
Element Id	7697
Label	Depressional Storage Overflow
Time	(N/A)
Message	Reverse flow conditions encountered for one or more headwater elevations. Calculated reverse flows may be approximate.
Source	Warning

Scenario Calculation Summary

Messages

Message Id	39
Scenario	2 Yr-1hr
Element Type	Composite Outlet Structure
Element Id	7697
Label	Depressional Storage Overflow
Time	(N/A)
Message	Reverse flow conditions encountered for one or more headwater elevations. Calculated reverse flows may be approximate.
Source	Warning

Message Id	-1
Scenario	2 Yr-24hr
Element Type	Composite Outlet Structure
Element Id	5390
Label	TAM7
Time	(N/A)
Message	A user defined rating table is being used with a non-free outfall tailwater setting. For user defined rating tables it is suggested to use only free outfall tailwater as tailwater effects are not handled.
Source	Precalculation

Scenario Calculation Summary

Scenario Summary	
ID	1720
Label	100Yr-3Hr
Notes	
Active Topology	<I> Base Active Topology
Hydrology	<I> Base Hydrology
Rainfall Runoff	100Yr-3Hr
Physical	<I> Base Physical
Initial Condition	<I> Base Initial Condition
Boundary Condition	<I> Base Boundary Condition
Infiltration and Inflow	<I> Base Infiltration and Inflow
Output	<I> Base Output
User Data Extensions	<I> Base User Data Extensions
PondPack Engine Calculation Options	<I> 12Hr

Output Summary			
Output Increment	0.100 hours	Duration	48.000 hours

Rainfall Summary			
Return Event Tag	12 Hr	Rainfall Type	Time-Depth Curve
Total Depth	5.5 in	Storm Event	100YR- 3HR

ICPM Output Summary			
Target Convergence	0.00 ft ³ /s	ICPM Time Step	0.100 hours
Maximum Iterations	35		

Executive Summary (Nodes)

Label	Scenario	Return Event (years)	Truncation	Hydrograph Volume (ac-ft)	Time to Peak (hours)	Peak Flow (ft ³ /s)	Maximum Water Surface Elevation (ft)	Maximum Pond Storage (ac-ft)
001	100Yr-3Hr	100	None	3.834	1.000	31.64	(N/A)	(N/A)
002	100Yr-3Hr	100	None	0.416	0.800	3.69	(N/A)	(N/A)
003	100Yr-3Hr	100	None	0.046	0.800	0.41	(N/A)	(N/A)
004	100Yr-3Hr	100	None	0.199	0.900	1.75	(N/A)	(N/A)
005	100Yr-3Hr	100	None	0.108	0.800	0.96	(N/A)	(N/A)
101	100Yr-3Hr	100	None	0.535	0.900	4.63	(N/A)	(N/A)
102	100Yr-3Hr	100	None	0.022	0.900	0.20	(N/A)	(N/A)
APN2	100Yr-3Hr	100	None	2.307	0.900	20.39	(N/A)	(N/A)
APN3	100Yr-3Hr	100	None	15.621	1.000	128.57	(N/A)	(N/A)
APN3 (IN)	100Yr-3Hr	100	None	15.621	1.000	128.57	(N/A)	(N/A)
APN3 (OUT)	100Yr-3Hr	100	None	15.558	3.400	12.26	683.08	12.686
APN4 (IN)	100Yr-3Hr	100	None	5.016	1.000	40.57	(N/A)	(N/A)
APN4 (OUT)	100Yr-3Hr	100	None	4.973	3.300	3.95	685.47	4.076
APN4	100Yr-3Hr	100	None	5.016	1.000	40.57	(N/A)	(N/A)

Scenario Calculation Summary

Executive Summary (Nodes)

Label	Scenario	Return Event (years)	Truncation	Hydrograph Volume (ac-ft)	Time to Peak (hours)	Peak Flow (ft ³ /s)	Maximum Water Surface Elevation (ft)	Maximum Pond Storage (ac-ft)
APN5 (IN)	100Yr-3Hr	100	None	16.565	1.000	94.29	(N/A)	(N/A)
APN5 (OUT)	100Yr-3Hr	100	None	16.455	3.700	6.62	680.50	10.921
APN5	100Yr-3Hr	100	None	11.591	1.000	90.85	(N/A)	(N/A)
APN6 (IN)	100Yr-3Hr	100	None	31.934	1.200	117.32	(N/A)	(N/A)
APN6 (OUT)	100Yr-3Hr	100	None	28.421	3.800	11.80	669.95	14.691
APN6	100Yr-3Hr	100	None	15.479	1.200	112.44	(N/A)	(N/A)
ASH4	100Yr-3Hr	100	None	1.305	0.800	11.97	(N/A)	(N/A)
CLOW CREEK OUTFALL OFF-SITE	100Yr-3Hr	100	None	341.283	2.900	427.34	(N/A)	(N/A)
CREEK OUTFALL 1	100Yr-3Hr	100	None	60.329	3.300	51.75	(N/A)	(N/A)
CREEK OUTFALL 2	100Yr-3Hr	100	None	134.188	0.100	168.35	(N/A)	(N/A)
J-5	100Yr-3Hr	100	None	208.884	1.100	265.25	(N/A)	(N/A)
J-6	100Yr-3Hr	100	None	11.820	0.800	108.68	(N/A)	(N/A)
Offsite Flow (East)	100Yr-3Hr	100	None	0.108	0.800	0.96	(N/A)	(N/A)
Offsite Flow (South)	100Yr-3Hr	100	None	0.199	0.900	1.75	(N/A)	(N/A)
Offsite Flow (West)	100Yr-3Hr	100	None	0.046	0.800	0.41	(N/A)	(N/A)
On-Site Depressional Storage (IN)	100Yr-3Hr	100	None	0.416	0.800	3.69	(N/A)	(N/A)
On-Site Depressional Storage (OUT)	100Yr-3Hr	100	None	0.000	0.000	0.00	651.28	0.416
PR1	100Yr-3Hr	100	None	5.878	0.800	54.06	(N/A)	(N/A)
PR2	100Yr-3Hr	100	None	2.897	0.800	26.65	(N/A)	(N/A)
PR3	100Yr-3Hr	100	None	1.740	0.800	16.00	(N/A)	(N/A)
TAM1 (IN)	100Yr-3Hr	100	None	263.779	1.100	575.51	(N/A)	(N/A)
TAM1 (OUT)	100Yr-3Hr	100	None	263.369	2.300	362.08	664.80	28.059
TAM1	100Yr-3Hr	100	None	39.338	1.000	326.22	(N/A)	(N/A)
TAM2 (IN)	100Yr-3Hr	100	None	30.511	0.800	20.48	(N/A)	(N/A)
TAM2 (OUT)	100Yr-3Hr	100	None	29.942	3.100	13.80	664.11	1.299
TAM2	100Yr-3Hr	100	None	2.090	0.700	19.40	(N/A)	(N/A)
TAM3 (IN)	100Yr-3Hr	100	None	33.015	0.900	32.04	(N/A)	(N/A)

Scenario Calculation Summary

Executive Summary (Nodes)

Label	Scenario	Return Event (years)	Truncation	Hydrograph Volume (ac-ft)	Time to Peak (hours)	Peak Flow (ft ³ /s)	Maximum Water Surface Elevation (ft)	Maximum Pond Storage (ac-ft)
TAM3 (OUT)	100Yr-3Hr	100	None	32.487	3.100	18.13	663.49	2.185
TAM3	100Yr-3Hr	100	None	3.073	0.800	27.55	(N/A)	(N/A)
TAM4 (IN)	100Yr-3Hr	100	None	50.590	1.100	144.34	(N/A)	(N/A)
TAM4 (OUT)	100Yr-3Hr	100	None	48.090	3.700	23.29	663.09	16.820
TAM4	100Yr-3Hr	100	None	18.103	1.100	135.56	(N/A)	(N/A)
TAM5 (IN)	100Yr-3Hr	100	None	51.036	1.100	35.13	(N/A)	(N/A)
TAM5 (OUT)	100Yr-3Hr	100	None	49.899	7.900	21.36	659.60	5.097
TAM5	100Yr-3Hr	100	None	2.946	0.900	25.79	(N/A)	(N/A)
TAM6 (IN)	100Yr-3Hr	100	None	269.247	2.100	380.84	(N/A)	(N/A)
TAM6 (OUT)	100Yr-3Hr	100	None	269.049	2.700	363.38	659.08	8.289
TAM6	100Yr-3Hr	100	None	5.878	0.900	50.41	(N/A)	(N/A)
TAM7 (IN)	100Yr-3Hr	100	None	339.291	2.300	432.75	(N/A)	(N/A)
TAM7 (OUT)	100Yr-3Hr	100	None	336.919	2.900	418.48	655.56	16.822
TAM7	100Yr-3Hr	100	None	20.344	1.100	155.31	(N/A)	(N/A)
West Tributary - Clow Creek (IN)	100Yr-3Hr	100	None	341.311	2.900	427.45	(N/A)	(N/A)
West Tributary - Clow Creek (OUT)	100Yr-3Hr	100	None	341.283	2.900	427.34	650.55	0.317

Executive Summary (Links)

Label	Type	Location	Hydrograph Volume (ac-ft)	Peak Time (hours)	Peak Flow (ft ³ /s)	End Point	Node Flow Direction
APN3 Outlet	Pond Outlet	Upstream	15.621	1.000	128.57	APN3	Pond Inflow
APN3 Outlet	Pond Outlet	Outflow	15.558	3.400	12.26	APN3	Pond Outflow
APN3 Outlet	Pond Outlet	Link	15.557	3.400	12.26		
APN3 Outlet	Pond Outlet	Downstream	263.779	1.100	575.51	TAM1	
APN4 Outlet	Pond Outlet	Upstream	5.016	1.000	40.57	APN4	Pond Inflow
APN4 Outlet	Pond Outlet	Outflow	4.973	3.300	3.95	APN4	Pond Outflow
APN4 Outlet	Pond Outlet	Link	4.973	3.300	3.95		
APN4 Outlet	Pond Outlet	Downstream	16.565	1.000	94.29	APN5	
APN5 Outlet	Pond Outlet	Upstream	16.565	1.000	94.29	APN5	Pond Inflow
APN5 Outlet	Pond Outlet	Outflow	16.455	3.700	6.62	APN5	Pond Outflow

Scenario Calculation Summary

Executive Summary (Links)

Label	Type	Location	Hydrograph Volume (ac-ft)	Peak Time (hours)	Peak Flow (ft ³ /s)	End Point	Node Flow Direction
APN5 Outlet	Pond Outlet	Link	16.455	3.700	6.62		
APN5 Outlet	Pond Outlet	Downstream	31.934	1.200	117.32	APN6	
APN6 Outlet	Pond Outlet	Upstream	31.934	1.200	117.32	APN6	Pond Inflow
APN6 Outlet	Pond Outlet	Outflow	28.421	3.800	11.80	APN6	Pond Outflow
APN6 Outlet	Pond Outlet	Link	28.421	3.800	11.80		
APN6 Outlet	Pond Outlet	Downstream	30.511	0.800	20.48	TAM2	
CO-3	Channel	Upstream	208.884	1.100	265.25	J-5	
CO-3	Channel	Link	208.884	1.200	265.25		
CO-3	Channel	Downstream	263.779	1.100	575.51	TAM1	
CO-4	Channel	Upstream	11.820	0.800	108.68	J-6	
CO-4	Channel	Link	11.820	0.900	108.68		
CO-4	Channel	Downstream	208.884	1.100	265.25	J-5	
OFFSITE FLOW	Pond Outlet	Upstream	341.311	2.900	427.45	West Tributary - Clow Creek	Pond Inflow
OFFSITE FLOW	Pond Outlet	Outflow	341.283	2.900	427.34	West Tributary - Clow Creek	Pond Outflow
OFFSITE FLOW	Pond Outlet	Link	341.283	2.900	427.34		
OFFSITE FLOW	Pond Outlet	Downstream	341.283	2.900	427.34	CLOW CREEK OUTFALL OFF-SITE	
OVERFLOW TO CREEK	Pond Outlet	Upstream	0.416	0.800	3.69	On-Site Depressional Storage	Pond Inflow
OVERFLOW TO CREEK	Pond Outlet	Outflow	0.000	0.000	0.00	On-Site Depressional Storage	Pond Outflow
OVERFLOW TO CREEK	Pond Outlet	Link	0.000	0.000	0.00		
OVERFLOW TO CREEK	Pond Outlet	Downstream	341.311	2.900	427.45	West Tributary - Clow Creek	
TAM1 OUTLET	Pond Outlet	Upstream	263.779	1.100	575.51	TAM1	Pond Inflow
TAM1 OUTLET	Pond Outlet	Outflow	263.369	2.300	362.08	TAM1	Pond Outflow
TAM1 OUTLET	Pond Outlet	Link	263.367	2.300	362.08		
TAM1 OUTLET	Pond Outlet	Downstream	269.247	2.100	380.84	TAM6	
TAM2 Outlet	Pond Outlet	Upstream	30.511	0.800	20.48	TAM2	Pond Inflow
TAM2 Outlet	Pond Outlet	Outflow	29.942	3.100	13.80	TAM2	Pond Outflow
TAM2 Outlet	Pond Outlet	Link	29.918	3.100	13.80		
TAM2 Outlet	Pond Outlet	Downstream	33.015	0.900	32.04	TAM3	

Scenario Calculation Summary

Executive Summary (Links)

Label	Type	Location	Hydrograph Volume (ac-ft)	Peak Time (hours)	Peak Flow (ft ³ /s)	End Point	Node Flow Direction
TAM3 Outlet	Pond Outlet	Upstream	33.015	0.900	32.04	TAM3	Pond Inflow
TAM3 Outlet	Pond Outlet	Outflow	32.487	3.100	18.13	TAM3	Pond Outflow
TAM3 Outlet	Pond Outlet	Link	32.460	3.100	18.13		
TAM3 Outlet	Pond Outlet	Downstream	50.590	1.100	144.34	TAM4	
TAM4 Outlet	Pond Outlet	Upstream	50.590	1.100	144.34	TAM4	Pond Inflow
TAM4 Outlet	Pond Outlet	Outflow	48.090	3.700	23.29	TAM4	Pond Outflow
TAM4 Outlet	Pond Outlet	Link	48.056	3.700	23.29		
TAM4 Outlet	Pond Outlet	Downstream	51.036	1.100	35.13	TAM5	
TAM5 Outlet	Pond Outlet	Upstream	51.036	1.100	35.13	TAM5	Pond Inflow
TAM5 Outlet	Pond Outlet	Outflow	49.899	7.900	21.36	TAM5	Pond Outflow
TAM5 Outlet	Pond Outlet	Link	49.899	7.900	21.36		
TAM5 Outlet	Pond Outlet	Downstream	339.291	2.300	432.75	TAM7	
TAM6	Pond Outlet	Upstream	269.247	2.100	380.84	TAM6	Pond Inflow
TAM6	Pond Outlet	Outflow	269.049	2.700	363.38	TAM6	Pond Outflow
TAM6	Pond Outlet	Link	269.049	2.700	363.38		
TAM6	Pond Outlet	Downstream	339.291	2.300	432.75	TAM7	
TAM7 Outlet	Pond Outlet	Upstream	339.291	2.300	432.75	TAM7	Pond Inflow
TAM7 Outlet	Pond Outlet	Outflow	336.919	2.900	418.48	TAM7	Pond Outflow
TAM7 Outlet	Pond Outlet	Link	336.868	2.900	418.48		
TAM7 Outlet	Pond Outlet	Downstream	341.311	2.900	427.45	West Tributary - Clow Creek	

Messages

Message Id	29
Scenario	2 Yr-24hr
Element Type	Catchment
Element Id	7688
Label	001
Time	(N/A)
Message	Tm > .25Tp. Computation increment, Tm, is greater than 1/4 Time to Peak on Unit Hydrograph. Using a larger Tc can solve this problem.
Source	Warning

Scenario Calculation Summary

Messages

Message Id	67
Scenario	2 Yr-24hr
Element Type	Composite Outlet Structure
Element Id	7699
Label	West Tributary Offsite Flow
Time	(N/A)
Message	Flow direction set to reverse for one ore more structures in composite outlet structure West Tributary Offsite Flow. To eliminate this warning, edit outlet data and select forward only. If reverse flow analysis is required, then the tailwater conditions must be set to interconnected pond.
Source	Warning

Message Id	67
Scenario	2 Yr-18hr
Element Type	Composite Outlet Structure
Element Id	7699
Label	West Tributary Offsite Flow
Time	(N/A)
Message	Flow direction set to reverse for one ore more structures in composite outlet structure West Tributary Offsite Flow. To eliminate this warning, edit outlet data and select forward only. If reverse flow analysis is required, then the tailwater conditions must be set to interconnected pond.
Source	Warning

Message Id	67
Scenario	2 Yr-12hr
Element Type	Composite Outlet Structure
Element Id	7699
Label	West Tributary Offsite Flow
Time	(N/A)
Message	Flow direction set to reverse for one ore more structures in composite outlet structure West Tributary Offsite Flow. To eliminate this warning, edit outlet data and select forward only. If reverse flow analysis is required, then the tailwater conditions must be set to interconnected pond.
Source	Warning

Message Id	67
Scenario	2 Yr-6hr
Element Type	Composite Outlet Structure
Element Id	7699
Label	West Tributary Offsite Flow
Time	(N/A)
Message	Flow direction set to reverse for one ore more structures in composite outlet structure West Tributary Offsite Flow. To eliminate this warning, edit outlet data and select forward only. If reverse flow analysis is required, then the tailwater conditions must be set to interconnected pond.
Source	Warning

Scenario Calculation Summary

Messages

Message Id	67
Scenario	2 Yr-3hr
Element Type	Composite Outlet Structure
Element Id	7699
Label	West Tributary Offsite Flow
Time	(N/A)
Message	Flow direction set to reverse for one ore more structures in composite outlet structure West Tributary Offsite Flow. To eliminate this warning, edit outlet data and select forward only. If reverse flow analysis is required, then the tailwater conditions must be set to interconnected pond.
Source	Warning

Message Id	67
Scenario	2 Yr-2hr
Element Type	Composite Outlet Structure
Element Id	7699
Label	West Tributary Offsite Flow
Time	(N/A)
Message	Flow direction set to reverse for one ore more structures in composite outlet structure West Tributary Offsite Flow. To eliminate this warning, edit outlet data and select forward only. If reverse flow analysis is required, then the tailwater conditions must be set to interconnected pond.
Source	Warning

Message Id	67
Scenario	2 Yr-1hr
Element Type	Composite Outlet Structure
Element Id	7699
Label	West Tributary Offsite Flow
Time	(N/A)
Message	Flow direction set to reverse for one ore more structures in composite outlet structure West Tributary Offsite Flow. To eliminate this warning, edit outlet data and select forward only. If reverse flow analysis is required, then the tailwater conditions must be set to interconnected pond.
Source	Warning

Message Id	39
Scenario	2 Yr-24hr
Element Type	Composite Outlet Structure
Element Id	7697
Label	Depressional Storage Overflow
Time	(N/A)
Message	Reverse flow conditions encountered for one or more headwater elevations. Calculated reverse flows may be approximate.
Source	Warning

Scenario Calculation Summary

Messages

Message Id	39
Scenario	2 Yr-18hr
Element Type	Composite Outlet Structure
Element Id	7697
Label	Depressional Storage Overflow
Time	(N/A)
Message	Reverse flow conditions encountered for one or more headwater elevations. Calculated reverse flows may be approximate.
Source	Warning

Message Id	39
Scenario	2 Yr-12hr
Element Type	Composite Outlet Structure
Element Id	7697
Label	Depressional Storage Overflow
Time	(N/A)
Message	Reverse flow conditions encountered for one or more headwater elevations. Calculated reverse flows may be approximate.
Source	Warning

Message Id	39
Scenario	2 Yr-6hr
Element Type	Composite Outlet Structure
Element Id	7697
Label	Depressional Storage Overflow
Time	(N/A)
Message	Reverse flow conditions encountered for one or more headwater elevations. Calculated reverse flows may be approximate.
Source	Warning

Message Id	39
Scenario	2 Yr-3hr
Element Type	Composite Outlet Structure
Element Id	7697
Label	Depressional Storage Overflow
Time	(N/A)
Message	Reverse flow conditions encountered for one or more headwater elevations. Calculated reverse flows may be approximate.
Source	Warning

Message Id	39
Scenario	2 Yr-2hr
Element Type	Composite Outlet Structure
Element Id	7697
Label	Depressional Storage Overflow
Time	(N/A)
Message	Reverse flow conditions encountered for one or more headwater elevations. Calculated reverse flows may be approximate.
Source	Warning

Scenario Calculation Summary

Messages

Message Id	39
Scenario	2 Yr-1hr
Element Type	Composite Outlet Structure
Element Id	7697
Label	Depressional Storage Overflow
Time	(N/A)
Message	Reverse flow conditions encountered for one or more headwater elevations. Calculated reverse flows may be approximate.
Source	Warning

Message Id	-1
Scenario	2 Yr-24hr
Element Type	Composite Outlet Structure
Element Id	5390
Label	TAM7
Time	(N/A)
Message	A user defined rating table is being used with a non-free outfall tailwater setting. For user defined rating tables it is suggested to use only free outfall tailwater as tailwater effects are not handled.
Source	Precalculation

Scenario Calculation Summary

Scenario Summary	
ID	1721
Label	100Yr-2Hr
Notes	
Active Topology	<I> Base Active Topology
Hydrology	<I> Base Hydrology
Rainfall Runoff	100Yr-2Hr
Physical	<I> Base Physical
Initial Condition	<I> Base Initial Condition
Boundary Condition	<I> Base Boundary Condition
Infiltration and Inflow	<I> Base Infiltration and Inflow
Output	<I> Base Output
User Data Extensions	<I> Base User Data Extensions
PondPack Engine Calculation Options	<I> 12Hr

Output Summary			
Output Increment	0.100 hours	Duration	48.000 hours

Rainfall Summary			
Return Event Tag	12 Hr	Rainfall Type	Time-Depth Curve
Total Depth	5.0 in	Storm Event	100YR- 2HR

ICPM Output Summary			
Target Convergence	0.00 ft ³ /s	ICPM Time Step	0.100 hours
Maximum Iterations	35		

Executive Summary (Nodes)

Label	Scenario	Return Event (years)	Truncation	Hydrograph Volume (ac-ft)	Time to Peak (hours)	Peak Flow (ft ³ /s)	Maximum Water Surface Elevation (ft)	Maximum Pond Storage (ac-ft)
001	100Yr-2Hr	100	None	3.217	0.800	34.44	(N/A)	(N/A)
002	100Yr-2Hr	100	None	0.358	0.600	4.32	(N/A)	(N/A)
003	100Yr-2Hr	100	None	0.039	0.600	0.48	(N/A)	(N/A)
004	100Yr-2Hr	100	None	0.172	0.700	2.04	(N/A)	(N/A)
005	100Yr-2Hr	100	None	0.089	0.600	1.12	(N/A)	(N/A)
101	100Yr-2Hr	100	None	0.444	0.700	5.18	(N/A)	(N/A)
102	100Yr-2Hr	100	None	0.019	0.600	0.22	(N/A)	(N/A)
APN2	100Yr-2Hr	100	None	1.953	0.600	23.67	(N/A)	(N/A)
APN3	100Yr-2Hr	100	None	13.630	0.800	144.89	(N/A)	(N/A)
APN3 (IN)	100Yr-2Hr	100	None	13.630	0.800	144.89	(N/A)	(N/A)
APN3 (OUT)	100Yr-2Hr	100	None	13.571	2.500	12.12	682.95	11.506
APN4 (IN)	100Yr-2Hr	100	None	4.341	0.800	45.07	(N/A)	(N/A)
APN4 (OUT)	100Yr-2Hr	100	None	4.302	2.400	3.86	685.07	3.660
APN4	100Yr-2Hr	100	None	4.341	0.800	45.07	(N/A)	(N/A)

Scenario Calculation Summary

Executive Summary (Nodes)

Label	Scenario	Return Event (years)	Truncation	Hydrograph Volume (ac-ft)	Time to Peak (hours)	Peak Flow (ft ³ /s)	Maximum Water Surface Elevation (ft)	Maximum Pond Storage (ac-ft)
APN5 (IN)	100Yr-2Hr	100	None	14.327	0.900	102.92	(N/A)	(N/A)
APN5 (OUT)	100Yr-2Hr	100	None	14.238	2.800	6.42	680.32	9.530
APN5	100Yr-2Hr	100	None	10.025	0.800	99.43	(N/A)	(N/A)
APN6 (IN)	100Yr-2Hr	100	None	27.374	1.000	124.08	(N/A)	(N/A)
APN6 (OUT)	100Yr-2Hr	100	None	24.673	2.900	10.58	669.68	12.671
APN6	100Yr-2Hr	100	None	13.136	1.000	119.33	(N/A)	(N/A)
ASH4	100Yr-2Hr	100	None	1.131	0.600	14.50	(N/A)	(N/A)
CLOW CREEK OUTFALL OFF-SITE	100Yr-2Hr	100	None	301.318	2.300	404.24	(N/A)	(N/A)
CREEK OUTFALL 1	100Yr-2Hr	100	None	49.518	2.400	42.79	(N/A)	(N/A)
CREEK OUTFALL 2	100Yr-2Hr	100	None	124.818	0.100	168.35	(N/A)	(N/A)
J-5	100Yr-2Hr	100	None	186.771	0.900	273.66	(N/A)	(N/A)
J-6	100Yr-2Hr	100	None	10.260	0.600	132.18	(N/A)	(N/A)
Offsite Flow (East)	100Yr-2Hr	100	None	0.089	0.600	1.12	(N/A)	(N/A)
Offsite Flow (South)	100Yr-2Hr	100	None	0.172	0.700	2.04	(N/A)	(N/A)
Offsite Flow (West)	100Yr-2Hr	100	None	0.039	0.600	0.48	(N/A)	(N/A)
On-Site Depressional Storage (IN)	100Yr-2Hr	100	None	0.358	0.600	4.32	(N/A)	(N/A)
On-Site Depressional Storage (OUT)	100Yr-2Hr	100	None	0.000	0.000	0.00	651.24	0.358
PR1	100Yr-2Hr	100	None	5.104	0.600	65.79	(N/A)	(N/A)
PR2	100Yr-2Hr	100	None	2.516	0.600	32.43	(N/A)	(N/A)
PR3	100Yr-2Hr	100	None	1.510	0.600	19.47	(N/A)	(N/A)
TAM1 (IN)	100Yr-2Hr	100	None	234.300	0.900	620.87	(N/A)	(N/A)
TAM1 (OUT)	100Yr-2Hr	100	None	233.896	1.800	360.94	664.79	27.974
TAM1	100Yr-2Hr	100	None	33.958	0.800	365.52	(N/A)	(N/A)
TAM2 (IN)	100Yr-2Hr	100	None	26.494	0.600	24.75	(N/A)	(N/A)
TAM2 (OUT)	100Yr-2Hr	100	None	25.992	2.100	12.56	664.02	1.218
TAM2	100Yr-2Hr	100	None	1.821	0.600	23.80	(N/A)	(N/A)
TAM3 (IN)	100Yr-2Hr	100	None	28.665	0.700	36.38	(N/A)	(N/A)

Scenario Calculation Summary

Executive Summary (Nodes)

Label	Scenario	Return Event (years)	Truncation	Hydrograph Volume (ac-ft)	Time to Peak (hours)	Peak Flow (ft ³ /s)	Maximum Water Surface Elevation (ft)	Maximum Pond Storage (ac-ft)
TAM3 (OUT)	100Yr-2Hr	100	None	28.270	2.200	16.90	663.41	2.076
TAM3	100Yr-2Hr	100	None	2.673	0.600	32.45	(N/A)	(N/A)
TAM4 (IN)	100Yr-2Hr	100	None	43.992	0.900	154.92	(N/A)	(N/A)
TAM4 (OUT)	100Yr-2Hr	100	None	41.763	2.900	21.99	662.90	14.739
TAM4	100Yr-2Hr	100	None	15.722	0.900	146.53	(N/A)	(N/A)
TAM5 (IN)	100Yr-2Hr	100	None	44.347	0.900	34.68	(N/A)	(N/A)
TAM5 (OUT)	100Yr-2Hr	100	None	43.499	7.500	19.65	659.47	4.737
TAM5	100Yr-2Hr	100	None	2.585	0.700	30.32	(N/A)	(N/A)
TAM6 (IN)	100Yr-2Hr	100	None	238.876	1.700	379.42	(N/A)	(N/A)
TAM6 (OUT)	100Yr-2Hr	100	None	238.679	2.300	354.41	658.99	7.991
TAM6	100Yr-2Hr	100	None	4.981	0.700	57.32	(N/A)	(N/A)
TAM7 (IN)	100Yr-2Hr	100	None	299.701	1.900	422.38	(N/A)	(N/A)
TAM7 (OUT)	100Yr-2Hr	100	None	297.661	2.400	400.68	655.43	16.352
TAM7	100Yr-2Hr	100	None	17.524	0.900	168.36	(N/A)	(N/A)
West Tributary - Clow Creek (IN)	100Yr-2Hr	100	None	301.341	2.300	404.78	(N/A)	(N/A)
West Tributary - Clow Creek (OUT)	100Yr-2Hr	100	None	301.318	2.300	404.24	650.44	0.287

Executive Summary (Links)

Label	Type	Location	Hydrograph Volume (ac-ft)	Peak Time (hours)	Peak Flow (ft ³ /s)	End Point	Node Flow Direction
APN3 Outlet	Pond Outlet	Upstream	13.630	0.800	144.89	APN3	Pond Inflow
APN3 Outlet	Pond Outlet	Outflow	13.571	2.500	12.12	APN3	Pond Outflow
APN3 Outlet	Pond Outlet	Link	13.571	2.500	12.12		
APN3 Outlet	Pond Outlet	Downstream	234.300	0.900	620.87	TAM1	
APN4 Outlet	Pond Outlet	Upstream	4.341	0.800	45.07	APN4	Pond Inflow
APN4 Outlet	Pond Outlet	Outflow	4.302	2.400	3.86	APN4	Pond Outflow
APN4 Outlet	Pond Outlet	Link	4.302	2.400	3.86		
APN4 Outlet	Pond Outlet	Downstream	14.327	0.900	102.92	APN5	
APN5 Outlet	Pond Outlet	Upstream	14.327	0.900	102.92	APN5	Pond Inflow
APN5 Outlet	Pond Outlet	Outflow	14.238	2.800	6.42	APN5	Pond Outflow

Scenario Calculation Summary

Executive Summary (Links)

Label	Type	Location	Hydrograph Volume (ac-ft)	Peak Time (hours)	Peak Flow (ft ³ /s)	End Point	Node Flow Direction
APN5 Outlet	Pond Outlet	Link	14.237	2.800	6.42		
APN5 Outlet	Pond Outlet	Downstream	27.374	1.000	124.08	APN6	
APN6 Outlet	Pond Outlet	Upstream	27.374	1.000	124.08	APN6	Pond Inflow
APN6 Outlet	Pond Outlet	Outflow	24.673	2.900	10.58	APN6	Pond Outflow
APN6 Outlet	Pond Outlet	Link	24.655	2.900	10.58		
APN6 Outlet	Pond Outlet	Downstream	26.494	0.600	24.75	TAM2	
CO-3	Channel	Upstream	186.771	0.900	273.66	J-5	
CO-3	Channel	Link	186.771	1.000	273.66		
CO-3	Channel	Downstream	234.300	0.900	620.87	TAM1	
CO-4	Channel	Upstream	10.260	0.600	132.18	J-6	
CO-4	Channel	Link	10.260	0.700	132.18		
CO-4	Channel	Downstream	186.771	0.900	273.66	J-5	
OFFSITE FLOW	Pond Outlet	Upstream	301.341	2.300	404.78	West Tributary - Clow Creek	Pond Inflow
OFFSITE FLOW	Pond Outlet	Outflow	301.318	2.300	404.24	West Tributary - Clow Creek	Pond Outflow
OFFSITE FLOW	Pond Outlet	Link	301.318	2.300	404.24		
OFFSITE FLOW	Pond Outlet	Downstream	301.318	2.300	404.24	CLOW CREEK OUTFALL OFF-SITE	
OVERFLOW TO CREEK	Pond Outlet	Upstream	0.358	0.600	4.32	On-Site Depressional Storage	Pond Inflow
OVERFLOW TO CREEK	Pond Outlet	Outflow	0.000	0.000	0.00	On-Site Depressional Storage	Pond Outflow
OVERFLOW TO CREEK	Pond Outlet	Link	0.000	0.000	0.00		
OVERFLOW TO CREEK	Pond Outlet	Downstream	301.341	2.300	404.78	West Tributary - Clow Creek	
TAM1 OUTLET	Pond Outlet	Upstream	234.300	0.900	620.87	TAM1	Pond Inflow
TAM1 OUTLET	Pond Outlet	Outflow	233.896	1.800	360.94	TAM1	Pond Outflow
TAM1 OUTLET	Pond Outlet	Link	233.894	1.800	360.94		
TAM1 OUTLET	Pond Outlet	Downstream	238.876	1.700	379.42	TAM6	
TAM2 Outlet	Pond Outlet	Upstream	26.494	0.600	24.75	TAM2	Pond Inflow
TAM2 Outlet	Pond Outlet	Outflow	25.992	2.100	12.56	TAM2	Pond Outflow
TAM2 Outlet	Pond Outlet	Link	25.973	2.100	12.56		
TAM2 Outlet	Pond Outlet	Downstream	28.665	0.700	36.38	TAM3	

Scenario Calculation Summary

Executive Summary (Links)

Label	Type	Location	Hydrograph Volume (ac-ft)	Peak Time (hours)	Peak Flow (ft ³ /s)	End Point	Node Flow Direction
TAM3 Outlet	Pond Outlet	Upstream	28.665	0.700	36.38	TAM3	Pond Inflow
TAM3 Outlet	Pond Outlet	Outflow	28.270	2.200	16.90	TAM3	Pond Outflow
TAM3 Outlet	Pond Outlet	Link	28.248	2.200	16.90		
TAM3 Outlet	Pond Outlet	Downstream	43.992	0.900	154.92	TAM4	
TAM4 Outlet	Pond Outlet	Upstream	43.992	0.900	154.92	TAM4	Pond Inflow
TAM4 Outlet	Pond Outlet	Outflow	41.763	2.900	21.99	TAM4	Pond Outflow
TAM4 Outlet	Pond Outlet	Link	41.735	2.900	21.99		
TAM4 Outlet	Pond Outlet	Downstream	44.347	0.900	34.68	TAM5	
TAM5 Outlet	Pond Outlet	Upstream	44.347	0.900	34.68	TAM5	Pond Inflow
TAM5 Outlet	Pond Outlet	Outflow	43.499	7.500	19.65	TAM5	Pond Outflow
TAM5 Outlet	Pond Outlet	Link	43.499	7.500	19.65		
TAM5 Outlet	Pond Outlet	Downstream	299.701	1.900	422.38	TAM7	
TAM6	Pond Outlet	Upstream	238.876	1.700	379.42	TAM6	Pond Inflow
TAM6	Pond Outlet	Outflow	238.679	2.300	354.41	TAM6	Pond Outflow
TAM6	Pond Outlet	Link	238.679	2.300	354.41		
TAM6	Pond Outlet	Downstream	299.701	1.900	422.38	TAM7	
TAM7 Outlet	Pond Outlet	Upstream	299.701	1.900	422.38	TAM7	Pond Inflow
TAM7 Outlet	Pond Outlet	Outflow	297.661	2.400	400.68	TAM7	Pond Outflow
TAM7 Outlet	Pond Outlet	Link	297.617	2.400	400.68		
TAM7 Outlet	Pond Outlet	Downstream	301.341	2.300	404.78	West Tributary - Clow Creek	

Messages

Message Id	29
Scenario	2 Yr-24hr
Element Type	Catchment
Element Id	7688
Label	001
Time	(N/A)
Message	Tm > .25Tp. Computation increment, Tm, is greater than 1/4 Time to Peak on Unit Hydrograph. Using a larger Tc can solve this problem.
Source	Warning

Scenario Calculation Summary

Messages

Message Id	67
Scenario	2 Yr-24hr
Element Type	Composite Outlet Structure
Element Id	7699
Label	West Tributary Offsite Flow
Time	(N/A)
Message	Flow direction set to reverse for one ore more structures in composite outlet structure West Tributary Offsite Flow. To eliminate this warning, edit outlet data and select forward only. If reverse flow analysis is required, then the tailwater conditions must be set to interconnected pond.
Source	Warning

Message Id	67
Scenario	2 Yr-18hr
Element Type	Composite Outlet Structure
Element Id	7699
Label	West Tributary Offsite Flow
Time	(N/A)
Message	Flow direction set to reverse for one ore more structures in composite outlet structure West Tributary Offsite Flow. To eliminate this warning, edit outlet data and select forward only. If reverse flow analysis is required, then the tailwater conditions must be set to interconnected pond.
Source	Warning

Message Id	67
Scenario	2 Yr-12hr
Element Type	Composite Outlet Structure
Element Id	7699
Label	West Tributary Offsite Flow
Time	(N/A)
Message	Flow direction set to reverse for one ore more structures in composite outlet structure West Tributary Offsite Flow. To eliminate this warning, edit outlet data and select forward only. If reverse flow analysis is required, then the tailwater conditions must be set to interconnected pond.
Source	Warning

Message Id	67
Scenario	2 Yr-6hr
Element Type	Composite Outlet Structure
Element Id	7699
Label	West Tributary Offsite Flow
Time	(N/A)
Message	Flow direction set to reverse for one ore more structures in composite outlet structure West Tributary Offsite Flow. To eliminate this warning, edit outlet data and select forward only. If reverse flow analysis is required, then the tailwater conditions must be set to interconnected pond.
Source	Warning

Scenario Calculation Summary

Messages

Message Id	67
Scenario	2 Yr-3hr
Element Type	Composite Outlet Structure
Element Id	7699
Label	West Tributary Offsite Flow
Time	(N/A)
Message	Flow direction set to reverse for one ore more structures in composite outlet structure West Tributary Offsite Flow. To eliminate this warning, edit outlet data and select forward only. If reverse flow analysis is required, then the tailwater conditions must be set to interconnected pond.
Source	Warning

Message Id	67
Scenario	2 Yr-2hr
Element Type	Composite Outlet Structure
Element Id	7699
Label	West Tributary Offsite Flow
Time	(N/A)
Message	Flow direction set to reverse for one ore more structures in composite outlet structure West Tributary Offsite Flow. To eliminate this warning, edit outlet data and select forward only. If reverse flow analysis is required, then the tailwater conditions must be set to interconnected pond.
Source	Warning

Message Id	67
Scenario	2 Yr-1hr
Element Type	Composite Outlet Structure
Element Id	7699
Label	West Tributary Offsite Flow
Time	(N/A)
Message	Flow direction set to reverse for one ore more structures in composite outlet structure West Tributary Offsite Flow. To eliminate this warning, edit outlet data and select forward only. If reverse flow analysis is required, then the tailwater conditions must be set to interconnected pond.
Source	Warning

Message Id	39
Scenario	2 Yr-24hr
Element Type	Composite Outlet Structure
Element Id	7697
Label	Depressional Storage Overflow
Time	(N/A)
Message	Reverse flow conditions encountered for one or more headwater elevations. Calculated reverse flows may be approximate.
Source	Warning

Scenario Calculation Summary

Messages

Message Id	39
Scenario	2 Yr-18hr
Element Type	Composite Outlet Structure
Element Id	7697
Label	Depressional Storage Overflow
Time	(N/A)
Message	Reverse flow conditions encountered for one or more headwater elevations. Calculated reverse flows may be approximate.
Source	Warning

Message Id	39
Scenario	2 Yr-12hr
Element Type	Composite Outlet Structure
Element Id	7697
Label	Depressional Storage Overflow
Time	(N/A)
Message	Reverse flow conditions encountered for one or more headwater elevations. Calculated reverse flows may be approximate.
Source	Warning

Message Id	39
Scenario	2 Yr-6hr
Element Type	Composite Outlet Structure
Element Id	7697
Label	Depressional Storage Overflow
Time	(N/A)
Message	Reverse flow conditions encountered for one or more headwater elevations. Calculated reverse flows may be approximate.
Source	Warning

Message Id	39
Scenario	2 Yr-3hr
Element Type	Composite Outlet Structure
Element Id	7697
Label	Depressional Storage Overflow
Time	(N/A)
Message	Reverse flow conditions encountered for one or more headwater elevations. Calculated reverse flows may be approximate.
Source	Warning

Message Id	39
Scenario	2 Yr-2hr
Element Type	Composite Outlet Structure
Element Id	7697
Label	Depressional Storage Overflow
Time	(N/A)
Message	Reverse flow conditions encountered for one or more headwater elevations. Calculated reverse flows may be approximate.
Source	Warning

Scenario Calculation Summary

Messages

Message Id	39
Scenario	2 Yr-1hr
Element Type	Composite Outlet Structure
Element Id	7697
Label	Depressional Storage Overflow
Time	(N/A)
Message	Reverse flow conditions encountered for one or more headwater elevations. Calculated reverse flows may be approximate.
Source	Warning

Message Id	-1
Scenario	2 Yr-24hr
Element Type	Composite Outlet Structure
Element Id	5390
Label	TAM7
Time	(N/A)
Message	A user defined rating table is being used with a non-free outfall tailwater setting. For user defined rating tables it is suggested to use only free outfall tailwater as tailwater effects are not handled.
Source	Precalculation

Scenario Calculation Summary

Scenario Summary			
ID	1722		
Label	100Yr-1Hr		
Notes			
Active Topology	<I> Base Active Topology		
Hydrology	<I> Base Hydrology		
Rainfall Runoff	100Yr-1Hr		
Physical	<I> Base Physical		
Initial Condition	<I> Base Initial Condition		
Boundary Condition	<I> Base Boundary Condition		
Infiltration and Inflow	<I> Base Infiltration and Inflow		
Output	<I> Base Output		
User Data Extensions	<I> Base User Data Extensions		
PondPack Engine Calculation Options	<I> 12Hr		
Output Summary			
Output Increment	0.100 hours	Duration	48.000 hours
Rainfall Summary			
Return Event Tag	12 Hr	Rainfall Type	Time-Depth Curve
Total Depth	4.0 in	Storm Event	100YR- 1HR
ICPM Output Summary			
Target Convergence	0.00 ft ³ /s	ICPM Time Step	0.100 hours
Maximum Iterations	35		

Executive Summary (Nodes)

Label	Scenario	Return Event (years)	Truncation	Hydrograph Volume (ac-ft)	Time to Peak (hours)	Peak Flow (ft ³ /s)	Maximum Water Surface Elevation (ft)	Maximum Pond Storage (ac-ft)
001	100Yr-1Hr	100	None	2.170	0.600	34.52	(N/A)	(N/A)
002	100Yr-1Hr	100	None	0.258	0.500	4.60	(N/A)	(N/A)
003	100Yr-1Hr	100	None	0.026	0.400	0.50	(N/A)	(N/A)
004	100Yr-1Hr	100	None	0.124	0.500	2.17	(N/A)	(N/A)
005	100Yr-1Hr	100	None	0.057	0.400	1.12	(N/A)	(N/A)
101	100Yr-1Hr	100	None	0.291	0.500	5.13	(N/A)	(N/A)
102	100Yr-1Hr	100	None	0.012	0.400	0.22	(N/A)	(N/A)
APN2	100Yr-1Hr	100	None	1.347	0.400	24.65	(N/A)	(N/A)
APN3	100Yr-1Hr	100	None	10.107	0.600	150.97	(N/A)	(N/A)
APN3 (IN)	100Yr-1Hr	100	None	10.107	0.600	150.97	(N/A)	(N/A)
APN3 (OUT)	100Yr-1Hr	100	None	10.057	1.600	11.69	682.55	8.718
APN4 (IN)	100Yr-1Hr	100	None	3.155	0.600	45.78	(N/A)	(N/A)
APN4 (OUT)	100Yr-1Hr	100	None	3.124	1.300	3.70	684.13	2.710
APN4	100Yr-1Hr	100	None	3.155	0.600	45.78	(N/A)	(N/A)

Scenario Calculation Summary

Executive Summary (Nodes)

Label	Scenario	Return Event (years)	Truncation	Hydrograph Volume (ac-ft)	Time to Peak (hours)	Peak Flow (ft ³ /s)	Maximum Water Surface Elevation (ft)	Maximum Pond Storage (ac-ft)
APN5 (IN)	100Yr-1Hr	100	None	10.402	0.700	106.18	(N/A)	(N/A)
APN5 (OUT)	100Yr-1Hr	100	None	10.332	2.000	5.99	679.94	6.947
APN5	100Yr-1Hr	100	None	7.278	0.700	102.75	(N/A)	(N/A)
APN6 (IN)	100Yr-1Hr	100	None	19.443	0.800	123.87	(N/A)	(N/A)
APN6 (OUT)	100Yr-1Hr	100	None	17.845	2.400	7.55	669.18	9.014
APN6	100Yr-1Hr	100	None	9.111	0.800	119.37	(N/A)	(N/A)
ASH4	100Yr-1Hr	100	None	0.823	0.400	16.27	(N/A)	(N/A)
CLOW CREEK OUTFALL OFF-SITE	100Yr-1Hr	100	None	233.204	1.900	312.46	(N/A)	(N/A)
CREEK OUTFALL 1	100Yr-1Hr	100	None	31.328	5.700	23.24	(N/A)	(N/A)
CREEK OUTFALL 2	100Yr-1Hr	100	None	110.035	0.100	168.35	(N/A)	(N/A)
J-5	100Yr-1Hr	100	None	150.418	0.800	270.21	(N/A)	(N/A)
J-6	100Yr-1Hr	100	None	7.515	0.400	149.46	(N/A)	(N/A)
Offsite Flow (East)	100Yr-1Hr	100	None	0.057	0.400	1.12	(N/A)	(N/A)
Offsite Flow (South)	100Yr-1Hr	100	None	0.124	0.500	2.17	(N/A)	(N/A)
Offsite Flow (West)	100Yr-1Hr	100	None	0.026	0.400	0.50	(N/A)	(N/A)
On-Site Depressional Storage (IN)	100Yr-1Hr	100	None	0.258	0.500	4.60	(N/A)	(N/A)
On-Site Depressional Storage (OUT)	100Yr-1Hr	100	None	0.000	0.000	0.00	651.16	0.258
PR1	100Yr-1Hr	100	None	3.741	0.400	74.45	(N/A)	(N/A)
PR2	100Yr-1Hr	100	None	1.844	0.400	36.70	(N/A)	(N/A)
PR3	100Yr-1Hr	100	None	1.107	0.400	22.03	(N/A)	(N/A)
TAM1 (IN)	100Yr-1Hr	100	None	185.018	0.600	646.72	(N/A)	(N/A)
TAM1 (OUT)	100Yr-1Hr	100	None	184.621	1.300	322.28	664.39	25.097
TAM1	100Yr-1Hr	100	None	24.542	0.600	379.97	(N/A)	(N/A)
TAM2 (IN)	100Yr-1Hr	100	None	19.193	0.400	28.02	(N/A)	(N/A)
TAM2 (OUT)	100Yr-1Hr	100	None	18.785	1.200	9.10	663.77	1.021
TAM2	100Yr-1Hr	100	None	1.347	0.400	27.53	(N/A)	(N/A)
TAM3 (IN)	100Yr-1Hr	100	None	20.751	0.500	38.28	(N/A)	(N/A)

Scenario Calculation Summary

Executive Summary (Nodes)

Label	Scenario	Return Event (years)	Truncation	Hydrograph Volume (ac-ft)	Time to Peak (hours)	Peak Flow (ft ³ /s)	Maximum Water Surface Elevation (ft)	Maximum Pond Storage (ac-ft)
TAM3 (OUT)	100Yr-1Hr	100	None	20.544	1.300	12.46	663.12	1.660
TAM3	100Yr-1Hr	100	None	1.966	0.500	35.11	(N/A)	(N/A)
TAM4 (IN)	100Yr-1Hr	100	None	32.074	0.800	158.19	(N/A)	(N/A)
TAM4 (OUT)	100Yr-1Hr	100	None	30.249	2.000	19.00	662.53	10.693
TAM4	100Yr-1Hr	100	None	11.530	0.800	149.34	(N/A)	(N/A)
TAM5 (IN)	100Yr-1Hr	100	None	32.191	0.800	34.18	(N/A)	(N/A)
TAM5 (OUT)	100Yr-1Hr	100	None	31.750	6.700	15.82	659.19	3.911
TAM5	100Yr-1Hr	100	None	1.942	0.500	32.97	(N/A)	(N/A)
TAM6 (IN)	100Yr-1Hr	100	None	188.063	1.200	335.10	(N/A)	(N/A)
TAM6 (OUT)	100Yr-1Hr	100	None	187.866	1.700	294.33	658.37	5.918
TAM6	100Yr-1Hr	100	None	3.442	0.500	58.45	(N/A)	(N/A)
TAM7 (IN)	100Yr-1Hr	100	None	232.215	1.200	373.52	(N/A)	(N/A)
TAM7 (OUT)	100Yr-1Hr	100	None	230.748	1.900	312.35	654.76	13.895
TAM7	100Yr-1Hr	100	None	12.599	0.700	169.27	(N/A)	(N/A)
West Tributary - Clow Creek (IN)	100Yr-1Hr	100	None	233.221	1.900	312.56	(N/A)	(N/A)
West Tributary - Clow Creek (OUT)	100Yr-1Hr	100	None	233.204	1.900	312.46	649.97	0.166

Executive Summary (Links)

Label	Type	Location	Hydrograph Volume (ac-ft)	Peak Time (hours)	Peak Flow (ft ³ /s)	End Point	Node Flow Direction
APN3 Outlet	Pond Outlet	Upstream	10.107	0.600	150.97	APN3	Pond Inflow
APN3 Outlet	Pond Outlet	Outflow	10.057	1.600	11.69	APN3	Pond Outflow
APN3 Outlet	Pond Outlet	Link	10.057	1.600	11.69		
APN3 Outlet	Pond Outlet	Downstream	185.018	0.600	646.72	TAM1	
APN4 Outlet	Pond Outlet	Upstream	3.155	0.600	45.78	APN4	Pond Inflow
APN4 Outlet	Pond Outlet	Outflow	3.124	1.300	3.70	APN4	Pond Outflow
APN4 Outlet	Pond Outlet	Link	3.124	1.300	3.70		
APN4 Outlet	Pond Outlet	Downstream	10.402	0.700	106.18	APN5	
APN5 Outlet	Pond Outlet	Upstream	10.402	0.700	106.18	APN5	Pond Inflow
APN5 Outlet	Pond Outlet	Outflow	10.332	2.000	5.99	APN5	Pond Outflow

Scenario Calculation Summary

Executive Summary (Links)

Label	Type	Location	Hydrograph Volume (ac-ft)	Peak Time (hours)	Peak Flow (ft ³ /s)	End Point	Node Flow Direction
APN5 Outlet	Pond Outlet	Link	10.332	2.000	5.99		
APN5 Outlet	Pond Outlet	Downstream	19.443	0.800	123.87	APN6	
APN6 Outlet	Pond Outlet	Upstream	19.443	0.800	123.87	APN6	Pond Inflow
APN6 Outlet	Pond Outlet	Outflow	17.845	2.400	7.55	APN6	Pond Outflow
APN6 Outlet	Pond Outlet	Link	17.834	2.400	7.55		
APN6 Outlet	Pond Outlet	Downstream	19.193	0.400	28.02	TAM2	
CO-3	Channel	Upstream	150.418	0.800	270.21	J-5	
CO-3	Channel	Link	150.418	0.900	270.21		
CO-3	Channel	Downstream	185.018	0.600	646.72	TAM1	
CO-4	Channel	Upstream	7.515	0.400	149.46	J-6	
CO-4	Channel	Link	7.515	0.500	149.46		
CO-4	Channel	Downstream	150.418	0.800	270.21	J-5	
OFFSITE FLOW	Pond Outlet	Upstream	233.221	1.900	312.56	West Tributary - Clow Creek	Pond Inflow
OFFSITE FLOW	Pond Outlet	Outflow	233.204	1.900	312.46	West Tributary - Clow Creek	Pond Outflow
OFFSITE FLOW	Pond Outlet	Link	233.204	1.900	312.46		
OFFSITE FLOW	Pond Outlet	Downstream	233.204	1.900	312.46	CLOW CREEK OUTFALL OFF-SITE	
OVERFLOW TO CREEK	Pond Outlet	Upstream	0.258	0.500	4.60	On-Site Depressional Storage	Pond Inflow
OVERFLOW TO CREEK	Pond Outlet	Outflow	0.000	0.000	0.00	On-Site Depressional Storage	Pond Outflow
OVERFLOW TO CREEK	Pond Outlet	Link	0.000	0.000	0.00		
OVERFLOW TO CREEK	Pond Outlet	Downstream	233.221	1.900	312.56	West Tributary - Clow Creek	
TAM1 OUTLET	Pond Outlet	Upstream	185.018	0.600	646.72	TAM1	Pond Inflow
TAM1 OUTLET	Pond Outlet	Outflow	184.621	1.300	322.28	TAM1	Pond Outflow
TAM1 OUTLET	Pond Outlet	Link	184.621	1.300	322.28		
TAM1 OUTLET	Pond Outlet	Downstream	188.063	1.200	335.10	TAM6	
TAM2 Outlet	Pond Outlet	Upstream	19.193	0.400	28.02	TAM2	Pond Inflow
TAM2 Outlet	Pond Outlet	Outflow	18.785	1.200	9.10	TAM2	Pond Outflow
TAM2 Outlet	Pond Outlet	Link	18.785	1.200	9.10		
TAM2 Outlet	Pond Outlet	Downstream	20.751	0.500	38.28	TAM3	

Scenario Calculation Summary

Executive Summary (Links)

Label	Type	Location	Hydrograph Volume (ac-ft)	Peak Time (hours)	Peak Flow (ft ³ /s)	End Point	Node Flow Direction
TAM3 Outlet	Pond Outlet	Upstream	20.751	0.500	38.28	TAM3	Pond Inflow
TAM3 Outlet	Pond Outlet	Outflow	20.544	1.300	12.46	TAM3	Pond Outflow
TAM3 Outlet	Pond Outlet	Link	20.544	1.300	12.46		
TAM3 Outlet	Pond Outlet	Downstream	32.074	0.800	158.19	TAM4	
TAM4 Outlet	Pond Outlet	Upstream	32.074	0.800	158.19	TAM4	Pond Inflow
TAM4 Outlet	Pond Outlet	Outflow	30.249	2.000	19.00	TAM4	Pond Outflow
TAM4 Outlet	Pond Outlet	Link	30.230	2.000	19.00		
TAM4 Outlet	Pond Outlet	Downstream	32.191	0.800	34.18	TAM5	
TAM5 Outlet	Pond Outlet	Upstream	32.191	0.800	34.18	TAM5	Pond Inflow
TAM5 Outlet	Pond Outlet	Outflow	31.750	6.700	15.82	TAM5	Pond Outflow
TAM5 Outlet	Pond Outlet	Link	31.730	6.700	15.82		
TAM5 Outlet	Pond Outlet	Downstream	232.215	1.200	373.52	TAM7	
TAM6	Pond Outlet	Upstream	188.063	1.200	335.10	TAM6	Pond Inflow
TAM6	Pond Outlet	Outflow	187.866	1.700	294.33	TAM6	Pond Outflow
TAM6	Pond Outlet	Link	187.864	1.700	294.33		
TAM6	Pond Outlet	Downstream	232.215	1.200	373.52	TAM7	
TAM7 Outlet	Pond Outlet	Upstream	232.215	1.200	373.52	TAM7	Pond Inflow
TAM7 Outlet	Pond Outlet	Outflow	230.748	1.900	312.35	TAM7	Pond Outflow
TAM7 Outlet	Pond Outlet	Link	230.748	1.900	312.35		
TAM7 Outlet	Pond Outlet	Downstream	233.221	1.900	312.56	West Tributary - Clow Creek	

Messages

Message Id	29
Scenario	2 Yr-24hr
Element Type	Catchment
Element Id	7688
Label	001
Time	(N/A)
Message	Tm > .25Tp. Computation increment, Tm, is greater than 1/4 Time to Peak on Unit Hydrograph. Using a larger Tc can solve this problem.
Source	Warning

Scenario Calculation Summary

Messages

Message Id	67
Scenario	2 Yr-24hr
Element Type	Composite Outlet Structure
Element Id	7699
Label	West Tributary Offsite Flow
Time	(N/A)
Message	Flow direction set to reverse for one ore more structures in composite outlet structure West Tributary Offsite Flow. To eliminate this warning, edit outlet data and select forward only. If reverse flow analysis is required, then the tailwater conditions must be set to interconnected pond.
Source	Warning

Message Id	67
Scenario	2 Yr-18hr
Element Type	Composite Outlet Structure
Element Id	7699
Label	West Tributary Offsite Flow
Time	(N/A)
Message	Flow direction set to reverse for one ore more structures in composite outlet structure West Tributary Offsite Flow. To eliminate this warning, edit outlet data and select forward only. If reverse flow analysis is required, then the tailwater conditions must be set to interconnected pond.
Source	Warning

Message Id	67
Scenario	2 Yr-12hr
Element Type	Composite Outlet Structure
Element Id	7699
Label	West Tributary Offsite Flow
Time	(N/A)
Message	Flow direction set to reverse for one ore more structures in composite outlet structure West Tributary Offsite Flow. To eliminate this warning, edit outlet data and select forward only. If reverse flow analysis is required, then the tailwater conditions must be set to interconnected pond.
Source	Warning

Message Id	67
Scenario	2 Yr-6hr
Element Type	Composite Outlet Structure
Element Id	7699
Label	West Tributary Offsite Flow
Time	(N/A)
Message	Flow direction set to reverse for one ore more structures in composite outlet structure West Tributary Offsite Flow. To eliminate this warning, edit outlet data and select forward only. If reverse flow analysis is required, then the tailwater conditions must be set to interconnected pond.
Source	Warning

Scenario Calculation Summary

Messages

Message Id	67
Scenario	2 Yr-3hr
Element Type	Composite Outlet Structure
Element Id	7699
Label	West Tributary Offsite Flow
Time	(N/A)
Message	Flow direction set to reverse for one ore more structures in composite outlet structure West Tributary Offsite Flow. To eliminate this warning, edit outlet data and select forward only. If reverse flow analysis is required, then the tailwater conditions must be set to interconnected pond.
Source	Warning

Message Id	67
Scenario	2 Yr-2hr
Element Type	Composite Outlet Structure
Element Id	7699
Label	West Tributary Offsite Flow
Time	(N/A)
Message	Flow direction set to reverse for one ore more structures in composite outlet structure West Tributary Offsite Flow. To eliminate this warning, edit outlet data and select forward only. If reverse flow analysis is required, then the tailwater conditions must be set to interconnected pond.
Source	Warning

Message Id	67
Scenario	2 Yr-1hr
Element Type	Composite Outlet Structure
Element Id	7699
Label	West Tributary Offsite Flow
Time	(N/A)
Message	Flow direction set to reverse for one ore more structures in composite outlet structure West Tributary Offsite Flow. To eliminate this warning, edit outlet data and select forward only. If reverse flow analysis is required, then the tailwater conditions must be set to interconnected pond.
Source	Warning

Message Id	39
Scenario	2 Yr-24hr
Element Type	Composite Outlet Structure
Element Id	7697
Label	Depressional Storage Overflow
Time	(N/A)
Message	Reverse flow conditions encountered for one or more headwater elevations. Calculated reverse flows may be approximate.
Source	Warning

Scenario Calculation Summary

Messages

Message Id	39
Scenario	2 Yr-18hr
Element Type	Composite Outlet Structure
Element Id	7697
Label	Depressional Storage Overflow
Time	(N/A)
Message	Reverse flow conditions encountered for one or more headwater elevations. Calculated reverse flows may be approximate.
Source	Warning

Message Id	39
Scenario	2 Yr-12hr
Element Type	Composite Outlet Structure
Element Id	7697
Label	Depressional Storage Overflow
Time	(N/A)
Message	Reverse flow conditions encountered for one or more headwater elevations. Calculated reverse flows may be approximate.
Source	Warning

Message Id	39
Scenario	2 Yr-6hr
Element Type	Composite Outlet Structure
Element Id	7697
Label	Depressional Storage Overflow
Time	(N/A)
Message	Reverse flow conditions encountered for one or more headwater elevations. Calculated reverse flows may be approximate.
Source	Warning

Message Id	39
Scenario	2 Yr-3hr
Element Type	Composite Outlet Structure
Element Id	7697
Label	Depressional Storage Overflow
Time	(N/A)
Message	Reverse flow conditions encountered for one or more headwater elevations. Calculated reverse flows may be approximate.
Source	Warning

Message Id	39
Scenario	2 Yr-2hr
Element Type	Composite Outlet Structure
Element Id	7697
Label	Depressional Storage Overflow
Time	(N/A)
Message	Reverse flow conditions encountered for one or more headwater elevations. Calculated reverse flows may be approximate.
Source	Warning

Scenario Calculation Summary

Messages

Message Id	39
Scenario	2 Yr-1hr
Element Type	Composite Outlet Structure
Element Id	7697
Label	Depressional Storage Overflow
Time	(N/A)
Message	Reverse flow conditions encountered for one or more headwater elevations. Calculated reverse flows may be approximate.
Source	Warning

Message Id	-1
Scenario	2 Yr-24hr
Element Type	Composite Outlet Structure
Element Id	5390
Label	TAM7
Time	(N/A)
Message	A user defined rating table is being used with a non-free outfall tailwater setting. For user defined rating tables it is suggested to use only free outfall tailwater as tailwater effects are not handled.
Source	Precalculation

EXHIBIT L

PROPOSED CONDITIONS

WATERSHED EXHIBIT

PROPOSED WATERSHED FOR **THE BELVEDERE** NAPERVILLE, ILLINOIS

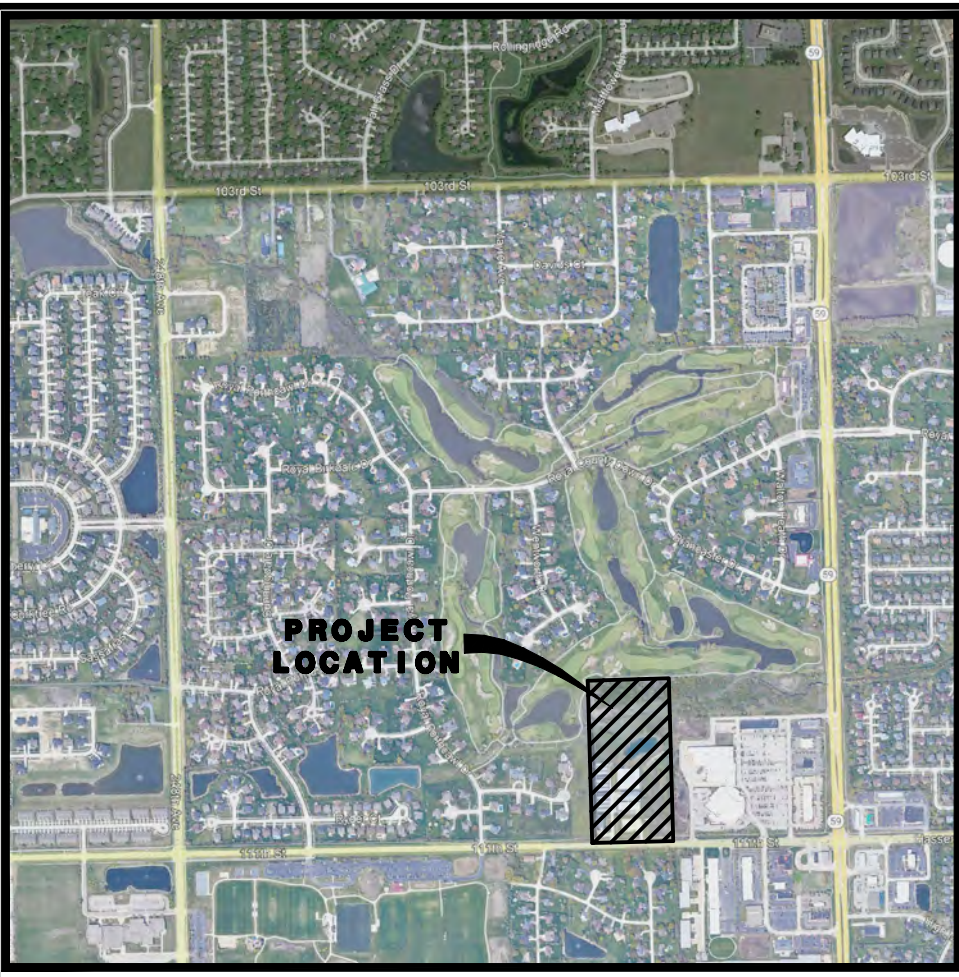

LOCATION MAP

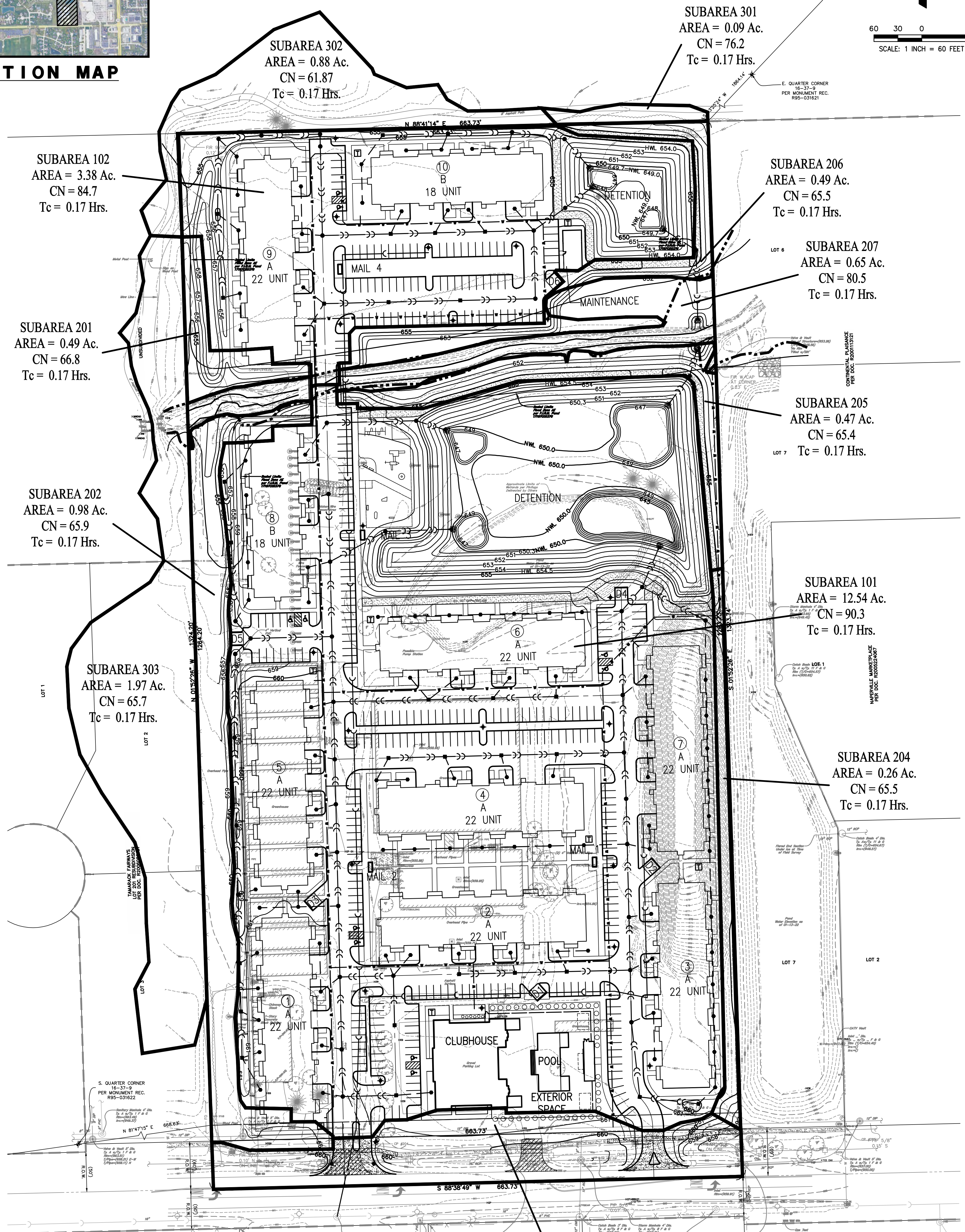
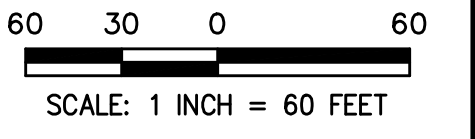

SUBAREA 102
AREA = 3.38 Ac.
CN = 84.7
Tc = 0.17 Hrs.

SUBAREA 201
AREA = 0.49 Ac.
CN = 66.8
Tc = 0.17 Hrs.

SUBAREA 202
AREA = 0.98 Ac.
CN = 65.9
Tc = 0.17 Hrs.

SUBAREA 303
AREA = 1.97 Ac.
CN = 65.7
Tc = 0.17 Hrs.

SUBAREA 302
AREA = 0.88 Ac.
CN = 61.87
Tc = 0.17 Hrs.

SUBAREA 301
AREA = 0.09 Ac.
CN = 76.2
Tc = 0.17 Hrs.

SUBAREA 206
AREA = 0.49 Ac.
CN = 65.5
Tc = 0.17 Hrs.

SUBAREA 207
AREA = 0.65 Ac.
CN = 80.5
Tc = 0.17 Hrs.

SUBAREA 205
AREA = 0.47 Ac.
CN = 65.4
Tc = 0.17 Hrs.

SUBAREA 101
AREA = 12.54 Ac.
CN = 90.3
Tc = 0.17 Hrs.

SUBAREA 204
AREA = 0.26 Ac.
CN = 65.5
Tc = 0.17 Hrs.

SUBAREA 203
AREA = 1.09 Ac.
CN = 77.1
Tc = 0.17 Hrs.

PREPARED FOR:
BRIDGE CAPITAL PARTNERS
899 PINE STREET #2000
SAN FRANCISCO, CA. 94108

PREPARED BY:
CEMCON, Ltd.
Consulting Engineers, Land Surveyors & Planners
2280 White Oak Circle, Suite 100
Aurora, Illinois 60502-9675
PH: 630.862.2100 FAX: 630.862.2199
E-Mail: info@cemcon.com Website: www.cemcon.com

DISC NO.: 904411 FILE NAME: WTRSHD PROP
DRAWN BY: KMS FLD. BK. / PG. NO.: ----
COMPLETION DATE: 03-29-22 JOB NO.: 904.411
XREF: TOPO PROJECT MANAGER: KMM

PROPOSED WATERSHED FOR THE BELVEDERE
CITY OF NAPERVILLE PROJECT NO. 22-1-023

Copyright © 2022 Cemcon, Ltd. All rights reserved.

DRAWING PATH: P:\004411\004411\004411\004411\WTRSHD\WTRSHD.DWG

EXHIBIT M

PROPOSED CONDITIONS
SUPPORTING DOCUMENTATION

Worksheet 2: Runoff Curve Number and Runoff

Project Location Naperville, Illinois

By KPB Date 3/23/2022
 Checked _____ Date _____

Circle one: Present Developed

RUNOFF AREA : 101

1. Runoff curve number (CN)

Soil Name and Hydrologic Group	Cover Description (cover type, treatment, and hydrologic condition; percent impervious; unconnected/connected impervious area ratio)	CN ^{1/}			Area <u>X</u> acres mi ² %	Product of CN x Area
		Table 2-2	Fig. 2-3	Fig. 2-4		
B	Grass (Open Space, Good)	61			1.81	110.41
C	Grass (Open Space, Good)	74			0.96	71.04
	Buildings	98			3.22	315.56
	Pavement	98			3.2	313.6
	Sidewalk	98			2.25	220.5
	Concrete Patio	98			0.32	31.36
B	Park - Wood Chips	61			0.18	10.98
	Open Water (Det Basin 1 @ NWL)	98			0.6	58.8
Totals =					12.54	1132.250

1/ Use only one CN source per line.

$$\text{CN (weighted)} = \frac{\text{Total Product}}{\text{Total Area}} = \frac{1132.250}{12.540} = 90.291$$

Use CN = 90.3

2. Runoff

Frequency yr
 Rainfall in
 Runoff, Q in

Storm #1	Storm #2	Storm #3

Worksheet 2: Runoff Curve Number and Runoff

Project _____
 Location Naperville, Illinois

By KPB Date 3/23/2022
 Checked _____ Date _____

Circle one: Present Developed

RUNOFF AREA : 201

1. Runoff curve number (CN)

Soil Name and Hydrologic Group	Cover Description (cover type, treatment, and hydrologic condition; percent impervious; unconnected/connected impervious area ratio)	CN ^{1/}			Area	Product of CN x Area
		Table 2-2	Fig. 2-3	Fig. 2-4	<u>X</u> acres mi ² %	
B	Grass (Open Space, Good)	61			0.31	18.91
C	Grass (Open Space, Good)	74				
	Buildings	98			0.01	0.98
	Sidewalk	98			0.01	0.98
Totals =					0.33	20.870

1/ Use only one CN source per line.

$$\text{CN (weighted)} = \frac{\text{Total Product}}{\text{Total Area}} = \frac{20.870}{0.330} = \underline{63.242}$$

Use CN = 63.2

2. Runoff

Frequency yr
 Rainfall in
 Runoff, Q in

Storm #1	Storm #2	Storm #3

Worksheet 2: Runoff Curve Number and Runoff

Project _____
 Location Naperville, Illinois

By KPB Date 3/23/2022
 Checked _____ Date _____

Circle one: Present Developed

RUNOFF AREA : 202

1. Runoff curve number (CN)

Soil Name and Hydrologic Group	Cover Description (cover type, treatment, and hydrologic condition; percent impervious; unconnected/connected impervious area ratio)	CN ^{1/}			Area	Product of CN x Area
		Table 2-2	Fig. 2-3	Fig. 2-4	<u>X</u> acres mi ² %	
B	Grass (Open Space, Good)	61			0.63	38.43
C	Grass (Open Space, Good)	74			0.34	25.16
	Sidewalk	98			0.01	0.98
Totals =					0.98	64.570

1/ Use only one CN source per line.

$$\text{CN (weighted)} = \frac{\text{Total Product}}{\text{Total Area}} = \frac{64.570}{0.980} = \underline{65.888}$$

Use CN = 65.9

2. Runoff

Frequency	yr	<table border="1" style="width: 100%;"><tr><td>Storm #1</td><td>Storm #2</td><td>Storm #3</td></tr><tr><td> </td><td> </td><td> </td></tr><tr><td> </td><td> </td><td> </td></tr><tr><td> </td><td> </td><td> </td></tr></table>	Storm #1	Storm #2	Storm #3									
Storm #1	Storm #2	Storm #3												
Rainfall	in													
Runoff, Q	in													

Worksheet 2: Runoff Curve Number and Runoff

Project _____
 Location Naperville, Illinois

By KPB Date 3/23/2022
 Checked _____ Date _____

Circle one: Present Developed

RUNOFF AREA : 203

1. Runoff curve number (CN)

Soil Name and Hydrologic Group	Cover Description (cover type, treatment, and hydrologic condition; percent impervious; unconnected/connected impervious area ratio)	CN ^{1/}			Area	Product of CN x Area
		Table 2-2	Fig. 2-3	Fig. 2-4	<u>X</u> acres mi ² %	
B	Grass (Open Space, Good)	61			0.46	28.06
C	Grass (Open Space, Good)	74			0.24	17.76
	Sidewalk	98			0.09	8.82
	Pavement	98			0.3	29.4
Totals =					1.09	84.040

1/ Use only one CN source per line.

$$\text{CN (weighted)} = \frac{\text{Total Product}}{\text{Total Area}} = \frac{84.040}{1.090} = \underline{77.101}$$

Use CN = 77.1

2. Runoff

Frequency yr
 Rainfall in
 Runoff, Q in

Storm #1	Storm #2	Storm #3

Worksheet 2: Runoff Curve Number and Runoff

Project _____
 Location Naperville, Illinois

By KPB Date 3/23/2022
 Checked _____ Date _____

Circle one: Present Developed

RUNOFF AREA : 204

1. Runoff curve number (CN)

Soil Name and Hydrologic Group	Cover Description (cover type, treatment, and hydrologic condition; percent impervious; unconnected/connected impervious area ratio)	CN ^{1/}			Area <u>X</u> acres mi ² %	Product of CN x Area
		Table 2-2	Fig. 2-3	Fig. 2-4		
B	Grass (Open Space, Good)	61			0.17	10.37
C	Grass (Open Space, Good)	74			0.09	6.66
Totals =					0.26	17.030

1/ Use only one CN source per line.

$$\text{CN (weighted)} = \frac{\text{Total Product}}{\text{Total Area}} = \frac{17.030}{0.260} = \underline{65.500}$$

Use CN = 65.5

2. Runoff

Frequency	yr	<table border="1" style="display: inline-table;"><tr><td>Storm #1</td><td>Storm #2</td><td>Storm #3</td></tr><tr><td> </td><td> </td><td> </td></tr><tr><td> </td><td> </td><td> </td></tr><tr><td> </td><td> </td><td> </td></tr></table>	Storm #1	Storm #2	Storm #3									
Storm #1	Storm #2	Storm #3												
Rainfall	in													
Runoff, Q	in													

Worksheet 2: Runoff Curve Number and Runoff

Project _____
 Location Naperville, Illinois

By KPB Date 3/23/2022
 Checked _____ Date _____

Circle one: Present Developed

RUNOFF AREA : 205

1. Runoff curve number (CN)

Soil Name and Hydrologic Group	Cover Description (cover type, treatment, and hydrologic condition; percent impervious; unconnected/connected impervious area ratio)	CN ^{1/}			Area <u>X</u> acres mi ² %	Product of CN x Area
		Table 2-2	Fig. 2-3	Fig. 2-4		
B	Grass (Open Space, Good)	61			0.31	18.91
C	Grass (Open Space, Good)	74			0.16	11.84
Totals =					0.47	30.750

1/ Use only one CN source per line.

$$\text{CN (weighted)} = \frac{\text{Total Product}}{\text{Total Area}} = \frac{30.750}{0.470} = 65.426$$

Use CN = 65.4

2. Runoff

Frequency	yr	<table border="1" style="display: inline-table;"><tr><td>Storm #1</td><td>Storm #2</td><td>Storm #3</td></tr><tr><td> </td><td> </td><td> </td></tr><tr><td> </td><td> </td><td> </td></tr><tr><td> </td><td> </td><td> </td></tr></table>	Storm #1	Storm #2	Storm #3									
Storm #1	Storm #2	Storm #3												
Rainfall	in													
Runoff, Q	in													

Worksheet 2: Runoff Curve Number and Runoff

Project _____
 Location Naperville, Illinois

By KPB Date 3/23/2022
 Checked _____ Date _____

Circle one: Present Developed

RUNOFF AREA : 206

1. Runoff curve number (CN)

Soil Name and Hydrologic Group	Cover Description (cover type, treatment, and hydrologic condition; percent impervious; unconnected/connected impervious area ratio)	CN ^{1/}			Area <u>X</u> acres mi ² %	Product of CN x Area
		Table 2-2	Fig. 2-3	Fig. 2-4		
B	Grass (Open Space, Good)	61			0.32	19.52
C	Grass (Open Space, Good)	74			0.17	12.58
Totals =					0.49	32.100

1/ Use only one CN source per line.

$$\text{CN (weighted)} = \frac{\text{Total Product}}{\text{Total Area}} = \frac{32.100}{0.490} = \underline{65.510}$$

Use CN = 65.5

2. Runoff

Frequency yr
 Rainfall in
 Runoff, Q in

Storm #1	Storm #2	Storm #3

Worksheet 2: Runoff Curve Number and Runoff

Project _____
 Location Naperville, Illinois

By KPB Date 3/23/2022
 Checked _____ Date _____

Circle one: Present Developed

RUNOFF AREA : 207

1. Runoff curve number (CN)

Soil Name and Hydrologic Group	Cover Description (cover type, treatment, and hydrologic condition; percent impervious; unconnected/connected impervious area ratio)	CN ^{1/}			Area <u>X</u> acres mi ² %	Product of CN x Area
		Table 2-2	Fig. 2-3	Fig. 2-4		
B	Grass (Open Space, Good)	61			0.23	14.03
C	Grass (Open Space, Good)	74			0.12	8.88
	Open Water (Creek @ NWL)	98			0.3	29.4
Totals =					0.65	52.310

1/ Use only one CN source per line.

$$\text{CN (weighted)} = \frac{\text{Total Product}}{\text{Total Area}} = \frac{52.310}{0.650} = \underline{80.477}$$

Use CN = 80.5

2. Runoff

Frequency yr
 Rainfall in
 Runoff, Q in

Storm #1	Storm #2	Storm #3

Worksheet 2: Runoff Curve Number and Runoff

Project _____
 Location Naperville, Illinois

By KPB Date 3/23/2022
 Checked _____ Date _____

Circle one: Present Developed

RUNOFF AREA : 301

1. Runoff curve number (CN)

Soil Name and Hydrologic Group	Cover Description (cover type, treatment, and hydrologic condition; percent impervious; unconnected/connected impervious area ratio)	CN ^{1/}			Area <u>X</u> acres mi ² %	Product of CN x Area
		Table 2-2	Fig. 2-3	Fig. 2-4		
B	Grass (Open Space, Good)	61			0.04	2.44
C	Grass (Open Space, Good)	74			0.02	1.48
	Ashpalt Bike Path	98			0.03	2.94
Totals =					0.09	6.860

1/ Use only one CN source per line.

$$\text{CN (weighted)} = \frac{\text{Total Product}}{\text{Total Area}} = \frac{6.860}{0.090} = \underline{76.222}$$

Use CN = 76.2

2. Runoff

Frequency yr
 Rainfall in
 Runoff, Q in

Storm #1	Storm #2	Storm #3

Worksheet 2: Runoff Curve Number and Runoff

Project _____
 Location Naperville, Illinois

By KPB Date 3/23/2022
 Checked _____ Date _____

Circle one: Present Developed

RUNOFF AREA : 302

1. Runoff curve number (CN)

Soil Name and Hydrologic Group	Cover Description (cover type, treatment, and hydrologic condition; percent impervious; unconnected/connected impervious area ratio)	CN ^{1/}			Area <u>X</u> acres mi ² %	Product of CN x Area
		Table 2-2	Fig. 2-3	Fig. 2-4		
B	Grass (Open Space, Good)	61			0.49	29.89
C	Grass (Open Space, Good)	74			0.26	19.24
	Ashpalt Bike Path	98			0.13	12.74
Totals =					0.88	61.870

1/ Use only one CN source per line.

$$\text{CN (weighted)} = \frac{\text{Total Product}}{\text{Total Area}} = \frac{61.870}{0.880} = \underline{70.307}$$

Use CN = 70.3

2. Runoff

Frequency yr
 Rainfall in
 Runoff, Q in

Storm #1	Storm #2	Storm #3

Worksheet 2: Runoff Curve Number and Runoff

Project _____
 Location Naperville, Illinois

By KPB Date 3/23/2022
 Checked _____ Date _____

Circle one: Present Developed

RUNOFF AREA : 303

1. Runoff curve number (CN)

Soil Name and Hydrologic Group	Cover Description (cover type, treatment, and hydrologic condition; percent impervious; unconnected/connected impervious area ratio)	CN ^{1/}			Area	Product of CN x Area
		Table 2-2	Fig. 2-3	Fig. 2-4	<u>X</u> acres mi ² %	
B	Grass (Open Space, Good)	61			1.28	78.08
C	Grass (Open Space, Good)	74			0.68	50.32
	Open Water	98			0.01	0.98
Totals =					1.97	129.380

1/ Use only one CN source per line.

$$\text{CN (weighted)} = \frac{\text{Total Product}}{\text{Total Area}} = \frac{129.380}{1.970} = 65.675$$

Use CN = 65.7

2. Runoff

Frequency	yr	<table border="1" style="display: inline-table;"><tr><td>Storm #1</td><td>Storm #2</td><td>Storm #3</td></tr><tr><td> </td><td> </td><td> </td></tr><tr><td> </td><td> </td><td> </td></tr><tr><td> </td><td> </td><td> </td></tr></table>	Storm #1	Storm #2	Storm #3									
Storm #1	Storm #2	Storm #3												
Rainfall	in													
Runoff, Q	in													

Project _____
 Location Naperville, IL

By KPB Date 3/16/2022
 Checked _____ Date _____

Check one: Present Developed
 Check one: Tc Tt

Existing Condition
Subarea 001

NOTES: Space for as many as two segments per flow type can be used for each worksheet.
 Include a map, schematic, or description of flow segments.

Sheet Flow (Applicable to Tc only)

1. Surface Description (Table 3-1)
2. Manning's roughness coeff., n (Table 3-1)
3. Flow length, L (total L ≤ 300 ft)
4. Two-yr 24-hr rainfall, P₂
5. Land slope, s
6.
$$T_c = \frac{0.007 (nL)^{0.8}}{P_2^{0.5} s^{0.4}}$$

Segment ID		
	Dense Grass	
	0.24	
ft	100	
in	3.04	
ft/ft	0.04	
hr	0.185	+ = 0.185

Shallow Concentrated Flow

7. Surface description (paved or unpaved)
8. Flow length, L
9. Watercourse slope, s
10. Average velocity, V (figure 3-1)
11.
$$T_t = \frac{L}{3600 V}$$

Segment ID		
	unpaved	paved
	1093	
	0.008	
	1.45	
hr	0.209	+ = 0.209

Channel Flow

12. Cross sectional flow area, a
13. Wetted perimeter, pw
14. Hydraulic radius, r= a/pw compute r
15. Channel Slope, s
16. Manning's roughness coeff., n
17. $V = 1.49 r^{2/3} s^{1/2} / n$
18. Flow length, L
19.
$$T_t = \frac{L}{3600 V}$$

Segment ID		
ft ²		
ft		
ft		
ft/ft		
ft/s	3	
ft		
hr		+ =

20. Watershed or subarea T_c or T_t (add T_t in steps 6, 11, and 19) hr 0.394

Project _____
 Location Naperville, IL

By KPB Date 3/16/2022
 Checked _____ Date _____

Check one: Present Developed
 Check one: Tc Tt

Existing Condition
Subarea 002

NOTES: Space for as many as two segments per flow type can be used for each worksheet.
 Include a map, schematic, or description of flow segments.

Sheet Flow (Applicable to Tc only)

1. Surface Description (Table 3-1)
2. Manning's roughness coeff., n (Table 3-1)
3. Flow length, L (total L ≤ 300 ft)
4. Two-yr 24-hr rainfall, P₂
5. Land slope, s
6.
$$T_c = \frac{0.007 (nL)^{0.8}}{P_2^{0.5} s^{0.4}}$$

Segment ID		
	Dense Grass	
	0.24	
ft	92	
in	3.04	
ft/ft	0.01	
hr	0.301	+ = 0.301

Shallow Concentrated Flow

7. Surface description (paved or unpaved)
8. Flow length, L
9. Watercourse slope, s
10. Average velocity, V (figure 3-1)
11.
$$T_t = \frac{L}{3600 V}$$

Segment ID		
	unpaved	paved
hr		+ =

Channel Flow

12. Cross sectional flow area, a
13. Wetted perimeter, pw
14. Hydraulic radius, r= a/pw compute r
15. Channel Slope, s
16. Manning's roughness coeff., n
17. $V = 1.49 r^{2/3} s^{1/2} / n$
18. Flow length, L
19.
$$T_t = \frac{L}{3600 V}$$

Segment ID		
ft ²		
ft		
ft		
ft/ft		
ft/s	3	
ft		
hr		+ =

20. Watershed or subarea T_c or T_t (add T_t in steps 6, 11, and 19) hr 0.301

Project _____
 Location Naperville, IL

By KPB Date 3/16/2022
 Checked _____ Date _____

Check one: Present Developed
 Check one: Tc Tt

Existing Condition _____
 Subarea 003

NOTES: Space for as many as two segments per flow type can be used for each worksheet.
 Include a map, schematic, or description of flow segments.

Sheet Flow (Applicable to Tc only)

1. Surface Description (Table 3-1)
2. Manning's roughness coeff., n (Table 3-1)
3. Flow length, L (total L ≤ 300 ft)
4. Two-yr 24-hr rainfall, P₂
5. Land slope, s
6.
$$T_c = \frac{0.007 (nL)^{0.8}}{P_2^{0.5} s^{0.4}}$$

Segment ID		
	Dense Grass	
	0.24	
ft	74	
in	3.04	
ft/ft	0.02	
hr	0.192	+ = 0.192

Shallow Concentrated Flow

7. Surface description (paved or unpaved)
8. Flow length, L
9. Watercourse slope, s
10. Average velocity, V (figure 3-1)
11.
$$T_t = \frac{L}{3600 V}$$

Segment ID		
	unpaved	paved
hr		+ =

Channel Flow

12. Cross sectional flow area, a
13. Wetted perimeter, pw
14. Hydraulic radius, r= a/pw compute r
15. Channel Slope, s
16. Manning's roughness coeff., n
17. $V = 1.49 r^{2/3} s^{1/2} / n$
18. Flow length, L
19.
$$T_t = \frac{L}{3600 V}$$

Segment ID		
ft ²		
ft		
ft		
ft/ft		
ft/s	3	
ft		
hr		+ =

20. Watershed or subarea T_c or T_t (add T_t in steps 6, 11, and 19) hr 0.192

Project _____
 Location Naperville, IL

By KPB Date 3/16/2022
 Checked _____ Date _____

Check one: Present Developed
 Check one: Tc Tt

Existing Condition
Subarea 004

NOTES: Space for as many as two segments per flow type can be used for each worksheet.
 Include a map, schematic, or description of flow segments.

Sheet Flow (Applicable to Tc only)

1. Surface Description (Table 3-1)
2. Manning's roughness coeff., n (Table 3-1)
3. Flow length, L (total L ≤ 300 ft)
4. Two-yr 24-hr rainfall, P₂
5. Land slope, s
6.
$$T_c = \frac{0.007 (nL)^{0.8}}{P_2^{0.5} s^{0.4}}$$

Segment ID		
	Dense Grass	
	0.24	
ft	100	
in	3.04	
ft/ft	0.01	
hr	0.322	+ = 0.322

Shallow Concentrated Flow

7. Surface description (paved or unpaved)
8. Flow length, L
9. Watercourse slope, s
10. Average velocity, V (figure 3-1)
11.
$$T_t = \frac{L}{3600 V}$$

Segment ID		
	unpaved	paved
	75	
	0.01	
	1.63	
hr	0.013	+ = 0.013

Channel Flow

12. Cross sectional flow area, a
13. Wetted perimeter, pw
14. Hydraulic radius, r = a/pw compute r
15. Channel Slope, s
16. Manning's roughness coeff., n
17. $V = 1.49 r^{2/3} s^{1/2} / n$
18. Flow length, L
19.
$$T_t = \frac{L}{3600 V}$$

Segment ID		
ft ²		
ft		
ft		
ft/ft		
ft/s	3	
ft		
hr		+ =

20. Watershed or subarea T_c or T_t (add T_t in steps 6, 11, and 19) hr 0.335

Project _____
 Location Naperville, IL

By KPB Date 3/16/2022
 Checked _____ Date _____

Check one: Present Developed
 Check one: Tc Tt

Existing Condition
Subarea 005

NOTES: Space for as many as two segments per flow type can be used for each worksheet.
 Include a map, schematic, or description of flow segments.

Sheet Flow (Applicable to Tc only)

1. Surface Description (Table 3-1)
2. Manning's roughness coeff., n (Table 3-1)
3. Flow length, L (total L ≤ 300 ft)
4. Two-yr 24-hr rainfall, P₂
5. Land slope, s
6.
$$T_c = \frac{0.007 (nL)^{0.8}}{P_2^{0.5} s^{0.4}}$$

Segment ID		
	Dense Grass	
	0.24	
ft	100	
in	3.04	
ft/ft	0.07	
hr	0.148	+ = 0.148

Shallow Concentrated Flow

7. Surface description (paved or unpaved)
8. Flow length, L
9. Watercourse slope, s
10. Average velocity, V (figure 3-1)
11.
$$T_t = \frac{L}{3600 V}$$

Segment ID		
	unpaved	paved
	137	
	0.45	
	11.01	
hr	0.003	+ = 0.003

Channel Flow

12. Cross sectional flow area, a
13. Wetted perimeter, pw
14. Hydraulic radius, r= a/pw compute r
15. Channel Slope, s
16. Manning's roughness coeff., n
17. $V = 1.49 r^{2/3} s^{1/2} / n$
18. Flow length, L
19.
$$T_t = \frac{L}{3600 V}$$

Segment ID		
ft ²		
ft		
ft		
ft/ft		
ft/s	3	
ft		
hr		+ =

20. Watershed or subarea T_c or T_t (add T_t in steps 6, 11, and 19) hr 0.151

Project _____
 Location Naperville, IL

By KPB Date 3/16/2022
 Checked _____ Date _____

Check one: Present Developed
 Check one: Tc Tt

Existing Condition
Subarea 101

NOTES: Space for as many as two segments per flow type can be used for each worksheet.
 Include a map, schematic, or description of flow segments.

Sheet Flow (Applicable to Tc only)

1. Surface Description (Table 3-1)
2. Manning's roughness coeff., n (Table 3-1)
3. Flow length, L (total L ≤ 300 ft)
4. Two-yr 24-hr rainfall, P₂
5. Land slope, s
6.
$$T_c = \frac{0.007 (nL)^{0.8}}{P_2^{0.5} s^{0.4}}$$

Segment ID		
	Dense Grass	
	0.24	
ft	100	
in	3.04	
ft/ft	0.02	
hr	0.244	+ = 0.244

Shallow Concentrated Flow

7. Surface description (paved or unpaved)
8. Flow length, L
9. Watercourse slope, s
10. Average velocity, V (figure 3-1)
11.
$$T_t = \frac{L}{3600 V}$$

Segment ID		
	unpaved	paved
	68	
	0.02	
	2.30	
hr	0.008	+ = 0.008

Channel Flow

12. Cross sectional flow area, a
13. Wetted perimeter, pw
14. Hydraulic radius, r= a/pw compute r
15. Channel Slope, s
16. Manning's roughness coeff., n
17. $V = 1.49 r^{2/3} s^{1/2} / n$
18. Flow length, L
19.
$$T_t = \frac{L}{3600 V}$$

Segment ID		
ft ²		
ft		
ft		
ft/ft		
ft/s	3	
ft		
hr		+ =

20. Watershed or subarea T_c or T_t (add T_t in steps 6, 11, and 19) hr 0.252

Project _____
 Location Naperville, IL

By KPB Date 3/16/2022
 Checked _____ Date _____

Check one: Present Developed
 Check one: Tc Tt

Existing Condition _____
 Subarea 102

NOTES: Space for as many as two segments per flow type can be used for each worksheet.
 Include a map, schematic, or description of flow segments.

Sheet Flow (Applicable to Tc only)

1. Surface Description (Table 3-1)
2. Manning's roughness coeff., n (Table 3-1)
3. Flow length, L (total L ≤ 300 ft)
4. Two-yr 24-hr rainfall, P₂
5. Land slope, s
6.
$$T_c = \frac{0.007 (nL)^{0.8}}{P_2^{0.5} s^{0.4}}$$

Segment ID		
	Dense Grass	
	0.24	
ft	71	
in	3.04	
ft/ft	0.02	
hr	0.186	+ = 0.186

Shallow Concentrated Flow

7. Surface description (paved or unpaved)
8. Flow length, L
9. Watercourse slope, s
10. Average velocity, V (figure 3-1)
11.
$$T_t = \frac{L}{3600 V}$$

Segment ID		
	unpaved	paved
hr		+ =

Channel Flow

12. Cross sectional flow area, a
13. Wetted perimeter, pw
14. Hydraulic radius, r= a/pw compute r
15. Channel Slope, s
16. Manning's roughness coeff., n
17. $V = 1.49 r^{2/3} s^{1/2} / n$
18. Flow length, L
19.
$$T_t = \frac{L}{3600 V}$$

Segment ID		
ft ²		
ft		
ft		
ft/ft		
ft/s	3	
ft		
hr		+ =

20. Watershed or subarea T_c or T_t (add T_t in steps 6, 11, and 19) hr 0.186

PROJECT: THE BELVEDERE

OWNER: BRIDGE CAPITAL PARTNERS

Job No.: 904.411
By: KMM
Date: 6-May-22
Revised:

PREPARED BY: CEMCON, Ltd.

PROPOSED CONDITIONS: NORTH SWMF - OVERFLOW WEIR CALCULATIONS

EQUATIONS:

Overflow (Broad Crested Weir Eq.): $Q=C*L*(H)^{3/2}$

ASSUMPTIONS:

Overflow Elev.:

654	
-----	--

OVERFLOW:

Weir Coeff. C: 3.0

Elev.	Head, (H)	Length, (L)	Discharge, Q
654	0	20	0.00
654.5	0.5	40	42.43
655	1	60	180.00

PROJECT: THE BELVEDERE

OWNER: BRIDGE CAPITAL PARTNERS

Job No.: 904.411
By: KMM
Date: 6-May-22
Revised:

PREPARED BY: CEMCON, Ltd.

PROPOSED CONDITIONS: NORTH SWMF - OVERFLOW WEIR CALCULATIONS

EQUATIONS:

Overflow (Broad Crested Weir Eq.): $Q=C*L*(H)^{3/2}$

ASSUMPTIONS:

Overflow Elev.:

654.5	
-------	--

OVERFLOW:

Weir Coeff. C: 3.0

Elev.	Head, (H)	Length, (L)	Discharge, Q
654.5	0	20	0.00
655	0.5	40	42.43
655.5	1	60	180.00

EXHIBIT N

PROPOSED CONDITIONS

PONDPACK MODEL

Table of Contents

	Master Network Summary	1
UPDATED 100YR 12HR-48HR	Time-Depth Curve, 100 years	3
101		
	Unit Hydrograph Summary, 100 years	4
102		
	Unit Hydrograph Summary, 100 years	6
201		
	Unit Hydrograph Summary, 100 years	8
202		
	Unit Hydrograph Summary, 100 years	10
203		
	Unit Hydrograph Summary, 100 years	12
204		
	Unit Hydrograph Summary, 100 years	14
205		
	Unit Hydrograph Summary, 100 years	16
206		
	Unit Hydrograph Summary, 100 years	18
301		
	Unit Hydrograph Summary, 100 years	20
302		
	Unit Hydrograph Summary, 100 years	22
303		
	Unit Hydrograph Summary, 100 years	24
APN2		
	Unit Hydrograph Summary, 100 years	26
APN3		
	Unit Hydrograph Summary, 100 years	28
APN4		
	Unit Hydrograph Summary, 100 years	30
APN5		
	Unit Hydrograph Summary, 100 years	32
APN6		
	Unit Hydrograph Summary, 100 years	34

Table of Contents

ASH4	Unit Hydrograph Summary, 100 years	36
CREEK OUTFALL 1	Read Hydrograph, 100 years	38
CREEK OUTFALL 2	Read Hydrograph, 100 years	44
PR1	Unit Hydrograph Summary, 100 years	50
PR2	Unit Hydrograph Summary, 100 years	52
PR3	Unit Hydrograph Summary, 100 years	54
TAM1	Unit Hydrograph Summary, 100 years	56
TAM2	Unit Hydrograph Summary, 100 years	58
TAM3	Unit Hydrograph Summary, 100 years	60
TAM4	Unit Hydrograph Summary, 100 years	62
TAM5	Unit Hydrograph Summary, 100 years	64
TAM6	Unit Hydrograph Summary, 100 years	66
TAM7	Unit Hydrograph Summary, 100 years	68
APN3	Elevation vs. Volume Curve, 100 years	70
APN4	Elevation vs. Volume Curve, 100 years	71
APN5	Elevation vs. Volume Curve, 100 years	72
APN6	Elevation vs. Volume Curve, 100 years	73

Table of Contents

North Pond	Elevation vs. Volume Curve, 100 years	74
South Pond	Elevation vs. Volume Curve, 100 years	75
TAM1	Elevation vs. Volume Curve, 100 years	76
TAM2	Elevation vs. Volume Curve, 100 years	77
TAM3	Elevation vs. Volume Curve, 100 years	78
TAM4	Elevation vs. Volume Curve, 100 years	79
TAM5	Elevation vs. Volume Curve, 100 years	80
TAM6	Elevation vs. Volume Curve, 100 years	81
TAM7	Elevation vs. Volume Curve, 100 years	82
West Tributary - Clow Creek	Elevation vs. Volume Curve, 100 years	83
APN3 Outlet	Outlet Input Data, 100 years	84
APN4 Outlet	Outlet Input Data, 100 years	88
APN5	Outlet Input Data, 100 years	91
APN6	Outlet Input Data, 100 years	93
Rev North Pond Outlet	Outlet Input Data, 100 years	96
South Pond Outlet	Outlet Input Data, 100 years	98
TAM1	Outlet Input Data, 100 years	100

Table of Contents

TAM2	Outlet Input Data, 100 years	103
TAM3	Outlet Input Data, 100 years	106
TAM4	Outlet Input Data, 100 years	109
TAM5	Outlet Input Data, 100 years	113
TAM6	Outlet Input Data, 100 years	116
TAM7	Outlet Input Data, 100 years	119
West Tributary Offsite Flow	Outlet Input Data, 100 years	121

Subsection: Master Network Summary

Catchments Summary

Label	Scenario	Return Event (years)	Hydrograph Volume (ac-ft)	Time to Peak (hours)	Peak Flow (ft ³ /s)
101	100Yr-24Hr	100	7.736	16.000	9.38
102	100Yr-24Hr	100	1.895	16.000	2.44
201	100Yr-24Hr	100	0.187	16.000	0.28
202	100Yr-24Hr	100	0.365	16.000	0.55
203	100Yr-24Hr	100	0.528	16.000	0.73
204	100Yr-24Hr	100	0.096	16.000	0.15
205	100Yr-24Hr	100	0.173	16.000	0.26
206	100Yr-24Hr	100	0.180	16.000	0.27
301	100Yr-24Hr	100	0.043	16.000	0.06
302	100Yr-24Hr	100	0.292	16.000	0.46
303	100Yr-24Hr	100	0.729	16.000	1.10
APN2	100Yr-24Hr	100	4.564	16.000	6.47
APN3	100Yr-24Hr	100	27.760	16.000	35.60
APN4	100Yr-24Hr	100	9.182	16.000	12.12
APN5	100Yr-24Hr	100	21.258	16.100	28.10
APN6	100Yr-24Hr	100	30.359	16.100	42.34
ASH4	100Yr-24Hr	100	2.383	16.000	3.15
CREEK OUTFALL 1	100Yr-24Hr	100	219.206	21.400	102.72
CREEK OUTFALL 2	100Yr-24Hr	100	469.501	0.100	168.35
PR1	100Yr-24Hr	100	10.630	16.000	13.93
PR2	100Yr-24Hr	100	5.239	16.000	6.87
PR3	100Yr-24Hr	100	3.146	16.000	4.12
TAM1	100Yr-24Hr	100	72.626	16.000	96.74
TAM2	100Yr-24Hr	100	3.727	16.000	4.82
TAM3	100Yr-24Hr	100	5.527	16.000	7.19
TAM4	100Yr-24Hr	100	32.705	16.100	42.56
TAM5	100Yr-24Hr	100	5.134	16.000	6.45
TAM6	100Yr-24Hr	100	11.590	16.000	16.35
TAM7	100Yr-24Hr	100	37.850	16.100	50.65

Node Summary

Label	Scenario	Return Event (years)	Hydrograph Volume (ac-ft)	Time to Peak (hours)	Peak Flow (ft ³ /s)
CLOW CREEK OUTFALL OFF-SITE	100Yr-24Hr	100	963.869	19.100	397.43
J-5	100Yr-24Hr	100	714.668	18.000	251.81
J-6	100Yr-24Hr	100	21.397	16.000	28.07
Offsite Runoff (East)	100Yr-24Hr	100	0.096	16.000	0.15
Offsite Runoff (South)	100Yr-24Hr	100	0.528	16.000	0.73

Pond Summary

Subsection: Master Network Summary

Pond Summary

Label	Scenario	Return Event (years)	Hydrograph Volume (ac-ft)	Time to Peak (hours)	Peak Flow (ft ³ /s)	Maximum Water Surface Elevation (ft)	Maximum Pond Storage (ac-ft)
APN3 (IN)	100Yr-24Hr	100	27.760	16.000	35.60	(N/A)	(N/A)
APN3 (OUT)	100Yr-24Hr	100	27.560	20.000	14.00	684.84	14.710
APN4 (IN)	100Yr-24Hr	100	9.182	16.000	12.12	(N/A)	(N/A)
APN4 (OUT)	100Yr-24Hr	100	9.177	20.900	4.03	686.31	5.081
APN5 (IN)	100Yr-24Hr	100	30.435	16.100	31.46	(N/A)	(N/A)
APN5 (OUT)	100Yr-24Hr	100	30.283	16.300	31.22	681.22	8.223
APN6 (IN)	100Yr-24Hr	100	60.642	16.200	73.51	(N/A)	(N/A)
APN6 (OUT)	100Yr-24Hr	100	59.212	21.300	23.60	673.02	31.387
North Pond (IN)	100Yr-24Hr	100	2.188	16.000	2.89	(N/A)	(N/A)
North Pond (OUT)	100Yr-24Hr	100	2.188	17.200	1.37	653.30	1.002
South Pond (IN)	100Yr-24Hr	100	7.736	16.000	9.38	(N/A)	(N/A)
South Pond (OUT)	100Yr-24Hr	100	6.578	24.000	1.34	654.40	6.427
TAM1 (IN)	100Yr-24Hr	100	814.483	17.100	346.76	(N/A)	(N/A)
TAM1 (OUT)	100Yr-24Hr	100	807.392	18.400	323.59	664.41	25.196
TAM2 (IN)	100Yr-24Hr	100	62.939	21.100	24.71	(N/A)	(N/A)
TAM2 (OUT)	100Yr-24Hr	100	62.774	21.700	23.86	665.88	2.991
TAM3 (IN)	100Yr-24Hr	100	68.301	21.700	25.30	(N/A)	(N/A)
TAM3 (OUT)	100Yr-24Hr	100	68.084	22.300	25.75	665.36	4.605
TAM4 (IN)	100Yr-24Hr	100	100.789	16.000	57.70	(N/A)	(N/A)
TAM4 (OUT)	100Yr-24Hr	100	99.543	20.200	39.31	664.94	19.586
TAM5 (IN)	100Yr-24Hr	100	104.677	19.100	42.21	(N/A)	(N/A)
TAM5 (OUT)	100Yr-24Hr	100	103.953	20.600	40.89	661.03	6.701
TAM6 (IN)	100Yr-24Hr	100	818.982	18.200	334.24	(N/A)	(N/A)
TAM6 (OUT)	100Yr-24Hr	100	817.862	18.900	328.88	658.73	7.127
TAM7 (IN)	100Yr-24Hr	100	959.665	18.400	396.39	(N/A)	(N/A)
TAM7 (OUT)	100Yr-24Hr	100	953.644	19.100	393.52	655.38	16.159
West Tributary - Clow Creek (IN)	100Yr-24Hr	100	964.086	19.100	397.50	(N/A)	(N/A)
West Tributary - Clow Creek (OUT)	100Yr-24Hr	100	963.869	19.100	397.43	650.39	0.273

Subsection: Time-Depth Curve
 Label: UPDATED 100YR 12HR-48HR

Return Event: 100 years
 Storm Event: 100YR-24HR

Time-Depth Curve: 100YR-24HR

Label	100YR-24HR
Start Time	0.000 hours
Increment	1.000 hours
End Time	24.000 hours
Return Event	100 years

CUMULATIVE RAINFALL (in)
Output Time Increment = 1.000 hours
Time on left represents time for first value in each row.

Time (hours)	Depth (in)	Depth (in)	Depth (in)	Depth (in)	Depth (in)
0.000	0.0	0.2	0.4	0.6	0.8
5.000	1.0	1.2	1.4	1.7	2.0
10.000	2.3	2.7	3.1	3.8	4.5
15.000	5.2	6.0	6.7	7.3	7.7
20.000	8.0	8.2	8.3	8.4	8.6

Subsection: Unit Hydrograph Summary
 Label: 101

Return Event: 100 years
 Storm Event: 100YR-24HR

Storm Event	100YR-24HR
Return Event	100 years
Duration	120.000 hours
Depth	8.6 in
Time of Concentration (Composite)	0.170 hours
Area (User Defined)	12.540 acres

Computational Time Increment	0.100 hours
Time to Peak (Computed)	16.000 hours
Flow (Peak, Computed)	9.38 ft ³ /s
Output Increment	0.100 hours
Time to Flow (Peak Interpolated Output)	16.000 hours
Flow (Peak Interpolated Output)	9.38 ft ³ /s

Drainage Area	
SCS CN (Composite)	90.300
Area (User Defined)	12.540 acres
Maximum Retention (Pervious)	1.1 in
Maximum Retention (Pervious, 20 percent)	0.2 in

Cumulative Runoff	
Cumulative Runoff Depth (Pervious)	7.4 in
Runoff Volume (Pervious)	7.736 ac-ft

Hydrograph Volume (Area under Hydrograph curve)	
Volume	7.736 ac-ft

SCS Unit Hydrograph Parameters	
Time of Concentration (Composite)	0.170 hours
Computational Time Increment	0.100 hours
Unit Hydrograph Shape Factor	483.432
K Factor	0.749
Receding/Rising, Tr/Tp	1.670
Unit peak, qp	62.32 ft ³ /s
Unit peak time, Tp	0.152 hours

Subsection: Unit Hydrograph Summary
Label: 101

Return Event: 100 years
Storm Event: 100YR-24HR

SCS Unit Hydrograph Parameters

Unit receding limb, Tr	0.608 hours
Total unit time, Tb	0.760 hours

Subsection: Unit Hydrograph Summary
 Label: 102

Return Event: 100 years
 Storm Event: 100YR-24HR

Storm Event	100YR-24HR
Return Event	100 years
Duration	120.000 hours
Depth	8.6 in
Time of Concentration (Composite)	0.170 hours
Area (User Defined)	3.380 acres

Computational Time Increment	0.100 hours
Time to Peak (Computed)	16.000 hours
Flow (Peak, Computed)	2.44 ft ³ /s
Output Increment	0.100 hours
Time to Flow (Peak Interpolated Output)	16.000 hours
Flow (Peak Interpolated Output)	2.44 ft ³ /s

Drainage Area	
SCS CN (Composite)	84.700
Area (User Defined)	3.380 acres
Maximum Retention (Pervious)	1.8 in
Maximum Retention (Pervious, 20 percent)	0.4 in

Cumulative Runoff	
Cumulative Runoff Depth (Pervious)	6.7 in
Runoff Volume (Pervious)	1.895 ac-ft

Hydrograph Volume (Area under Hydrograph curve)	
Volume	1.895 ac-ft

SCS Unit Hydrograph Parameters	
Time of Concentration (Composite)	0.170 hours
Computational Time Increment	0.100 hours
Unit Hydrograph Shape Factor	483.432
K Factor	0.749
Receding/Rising, Tr/Tp	1.670
Unit peak, qp	16.80 ft ³ /s
Unit peak time, Tp	0.152 hours

Subsection: Unit Hydrograph Summary
Label: 102

Return Event: 100 years
Storm Event: 100YR-24HR

SCS Unit Hydrograph Parameters

Unit receding limb, Tr	0.608 hours
Total unit time, Tb	0.760 hours

Subsection: Unit Hydrograph Summary
 Label: 201

Return Event: 100 years
 Storm Event: 100YR-24HR

Storm Event	100YR-24HR
Return Event	100 years
Duration	120.000 hours
Depth	8.6 in
Time of Concentration (Composite)	0.170 hours
Area (User Defined)	0.490 acres

Computational Time Increment	0.100 hours
Time to Peak (Computed)	16.000 hours
Flow (Peak, Computed)	0.28 ft ³ /s
Output Increment	0.100 hours
Time to Flow (Peak Interpolated Output)	16.000 hours
Flow (Peak Interpolated Output)	0.28 ft ³ /s

Drainage Area	
SCS CN (Composite)	66.800
Area (User Defined)	0.490 acres
Maximum Retention (Pervious)	5.0 in
Maximum Retention (Pervious, 20 percent)	1.0 in

Cumulative Runoff	
Cumulative Runoff Depth (Pervious)	4.6 in
Runoff Volume (Pervious)	0.187 ac-ft

Hydrograph Volume (Area under Hydrograph curve)	
Volume	0.187 ac-ft

SCS Unit Hydrograph Parameters	
Time of Concentration (Composite)	0.170 hours
Computational Time Increment	0.100 hours
Unit Hydrograph Shape Factor	483.432
K Factor	0.749
Receding/Rising, Tr/Tp	1.670
Unit peak, qp	2.44 ft ³ /s
Unit peak time, Tp	0.152 hours

Subsection: Unit Hydrograph Summary
Label: 201

Return Event: 100 years
Storm Event: 100YR-24HR

SCS Unit Hydrograph Parameters	
Unit receding limb, Tr	0.608 hours
Total unit time, Tb	0.760 hours

Subsection: Unit Hydrograph Summary
 Label: 202

Return Event: 100 years
 Storm Event: 100YR-24HR

Storm Event	100YR-24HR
Return Event	100 years
Duration	120.000 hours
Depth	8.6 in
Time of Concentration (Composite)	0.170 hours
Area (User Defined)	0.980 acres

Computational Time Increment	0.100 hours
Time to Peak (Computed)	16.000 hours
Flow (Peak, Computed)	0.55 ft ³ /s
Output Increment	0.100 hours
Time to Flow (Peak Interpolated Output)	16.000 hours
Flow (Peak Interpolated Output)	0.55 ft ³ /s

Drainage Area	
SCS CN (Composite)	65.900
Area (User Defined)	0.980 acres
Maximum Retention (Pervious)	5.2 in
Maximum Retention (Pervious, 20 percent)	1.0 in

Cumulative Runoff	
Cumulative Runoff Depth (Pervious)	4.5 in
Runoff Volume (Pervious)	0.365 ac-ft

Hydrograph Volume (Area under Hydrograph curve)	
Volume	0.365 ac-ft

SCS Unit Hydrograph Parameters	
Time of Concentration (Composite)	0.170 hours
Computational Time Increment	0.100 hours
Unit Hydrograph Shape Factor	483.432
K Factor	0.749
Receding/Rising, Tr/Tp	1.670
Unit peak, qp	4.87 ft ³ /s
Unit peak time, Tp	0.152 hours

Subsection: Unit Hydrograph Summary
Label: 202

Return Event: 100 years
Storm Event: 100YR-24HR

SCS Unit Hydrograph Parameters

Unit receding limb, Tr	0.608 hours
Total unit time, Tb	0.760 hours

Subsection: Unit Hydrograph Summary
 Label: 203

Return Event: 100 years
 Storm Event: 100YR-24HR

Storm Event	100YR-24HR
Return Event	100 years
Duration	120.000 hours
Depth	8.6 in
Time of Concentration (Composite)	0.170 hours
Area (User Defined)	1.090 acres

Computational Time Increment	0.100 hours
Time to Peak (Computed)	16.000 hours
Flow (Peak, Computed)	0.73 ft ³ /s
Output Increment	0.100 hours
Time to Flow (Peak Interpolated Output)	16.000 hours
Flow (Peak Interpolated Output)	0.73 ft ³ /s

Drainage Area	
SCS CN (Composite)	77.100
Area (User Defined)	1.090 acres
Maximum Retention (Pervious)	3.0 in
Maximum Retention (Pervious, 20 percent)	0.6 in

Cumulative Runoff	
Cumulative Runoff Depth (Pervious)	5.8 in
Runoff Volume (Pervious)	0.528 ac-ft

Hydrograph Volume (Area under Hydrograph curve)	
Volume	0.528 ac-ft

SCS Unit Hydrograph Parameters	
Time of Concentration (Composite)	0.170 hours
Computational Time Increment	0.100 hours
Unit Hydrograph Shape Factor	483.432
K Factor	0.749
Receding/Rising, Tr/Tp	1.670
Unit peak, qp	5.42 ft ³ /s
Unit peak time, Tp	0.152 hours

Subsection: Unit Hydrograph Summary
Label: 203

Return Event: 100 years
Storm Event: 100YR-24HR

SCS Unit Hydrograph Parameters

Unit receding limb, Tr	0.608 hours
Total unit time, Tb	0.760 hours

Subsection: Unit Hydrograph Summary
 Label: 204

Return Event: 100 years
 Storm Event: 100YR-24HR

Storm Event	100YR-24HR
Return Event	100 years
Duration	120.000 hours
Depth	8.6 in
Time of Concentration (Composite)	0.170 hours
Area (User Defined)	0.260 acres

Computational Time Increment	0.100 hours
Time to Peak (Computed)	16.000 hours
Flow (Peak, Computed)	0.15 ft ³ /s
Output Increment	0.100 hours
Time to Flow (Peak Interpolated Output)	16.000 hours
Flow (Peak Interpolated Output)	0.15 ft ³ /s

Drainage Area	
SCS CN (Composite)	65.500
Area (User Defined)	0.260 acres
Maximum Retention (Pervious)	5.3 in
Maximum Retention (Pervious, 20 percent)	1.1 in

Cumulative Runoff	
Cumulative Runoff Depth (Pervious)	4.4 in
Runoff Volume (Pervious)	0.096 ac-ft

Hydrograph Volume (Area under Hydrograph curve)	
Volume	0.096 ac-ft

SCS Unit Hydrograph Parameters	
Time of Concentration (Composite)	0.170 hours
Computational Time Increment	0.100 hours
Unit Hydrograph Shape Factor	483.432
K Factor	0.749
Receding/Rising, Tr/Tp	1.670
Unit peak, qp	1.29 ft ³ /s
Unit peak time, Tp	0.152 hours

Subsection: Unit Hydrograph Summary
Label: 204

Return Event: 100 years
Storm Event: 100YR-24HR

SCS Unit Hydrograph Parameters

Unit receding limb, Tr	0.608 hours
Total unit time, Tb	0.760 hours

Subsection: Unit Hydrograph Summary
 Label: 205

Return Event: 100 years
 Storm Event: 100YR-24HR

Storm Event	100YR-24HR
Return Event	100 years
Duration	120.000 hours
Depth	8.6 in
Time of Concentration (Composite)	0.170 hours
Area (User Defined)	0.470 acres

Computational Time Increment	0.100 hours
Time to Peak (Computed)	16.000 hours
Flow (Peak, Computed)	0.26 ft ³ /s
Output Increment	0.100 hours
Time to Flow (Peak Interpolated Output)	16.000 hours
Flow (Peak Interpolated Output)	0.26 ft ³ /s

Drainage Area	
SCS CN (Composite)	65.400
Area (User Defined)	0.470 acres
Maximum Retention (Pervious)	5.3 in
Maximum Retention (Pervious, 20 percent)	1.1 in

Cumulative Runoff	
Cumulative Runoff Depth (Pervious)	4.4 in
Runoff Volume (Pervious)	0.173 ac-ft

Hydrograph Volume (Area under Hydrograph curve)	
Volume	0.173 ac-ft

SCS Unit Hydrograph Parameters	
Time of Concentration (Composite)	0.170 hours
Computational Time Increment	0.100 hours
Unit Hydrograph Shape Factor	483.432
K Factor	0.749
Receding/Rising, Tr/Tp	1.670
Unit peak, qp	2.34 ft ³ /s
Unit peak time, Tp	0.152 hours

Subsection: Unit Hydrograph Summary
Label: 205

Return Event: 100 years
Storm Event: 100YR-24HR

SCS Unit Hydrograph Parameters

Unit receding limb, Tr	0.608 hours
Total unit time, Tb	0.760 hours

Subsection: Unit Hydrograph Summary
 Label: 206

Return Event: 100 years
 Storm Event: 100YR-24HR

Storm Event	100YR-24HR
Return Event	100 years
Duration	120.000 hours
Depth	8.6 in
Time of Concentration (Composite)	0.170 hours
Area (User Defined)	0.490 acres

Computational Time Increment	0.100 hours
Time to Peak (Computed)	16.000 hours
Flow (Peak, Computed)	0.27 ft ³ /s
Output Increment	0.100 hours
Time to Flow (Peak Interpolated Output)	16.000 hours
Flow (Peak Interpolated Output)	0.27 ft ³ /s

Drainage Area	
SCS CN (Composite)	65.500
Area (User Defined)	0.490 acres
Maximum Retention (Pervious)	5.3 in
Maximum Retention (Pervious, 20 percent)	1.1 in

Cumulative Runoff	
Cumulative Runoff Depth (Pervious)	4.4 in
Runoff Volume (Pervious)	0.180 ac-ft

Hydrograph Volume (Area under Hydrograph curve)	
Volume	0.180 ac-ft

SCS Unit Hydrograph Parameters	
Time of Concentration (Composite)	0.170 hours
Computational Time Increment	0.100 hours
Unit Hydrograph Shape Factor	483.432
K Factor	0.749
Receding/Rising, Tr/Tp	1.670
Unit peak, qp	2.44 ft ³ /s
Unit peak time, Tp	0.152 hours

Subsection: Unit Hydrograph Summary
Label: 206

Return Event: 100 years
Storm Event: 100YR-24HR

SCS Unit Hydrograph Parameters

Unit receding limb, Tr	0.608 hours
Total unit time, Tb	0.760 hours

Subsection: Unit Hydrograph Summary
 Label: 301

Return Event: 100 years
 Storm Event: 100YR-24HR

Storm Event	100YR-24HR
Return Event	100 years
Duration	120.000 hours
Depth	8.6 in
Time of Concentration (Composite)	0.170 hours
Area (User Defined)	0.090 acres

Computational Time Increment	0.100 hours
Time to Peak (Computed)	16.000 hours
Flow (Peak, Computed)	0.06 ft ³ /s
Output Increment	0.100 hours
Time to Flow (Peak Interpolated Output)	16.000 hours
Flow (Peak Interpolated Output)	0.06 ft ³ /s

Drainage Area	
SCS CN (Composite)	76.200
Area (User Defined)	0.090 acres
Maximum Retention (Pervious)	3.1 in
Maximum Retention (Pervious, 20 percent)	0.6 in

Cumulative Runoff	
Cumulative Runoff Depth (Pervious)	5.7 in
Runoff Volume (Pervious)	0.043 ac-ft

Hydrograph Volume (Area under Hydrograph curve)	
Volume	0.043 ac-ft

SCS Unit Hydrograph Parameters	
Time of Concentration (Composite)	0.170 hours
Computational Time Increment	0.100 hours
Unit Hydrograph Shape Factor	483.432
K Factor	0.749
Receding/Rising, Tr/Tp	1.670
Unit peak, qp	0.45 ft ³ /s
Unit peak time, Tp	0.152 hours

Subsection: Unit Hydrograph Summary
Label: 301

Return Event: 100 years
Storm Event: 100YR-24HR

SCS Unit Hydrograph Parameters

Unit receding limb, Tr	0.608 hours
Total unit time, Tb	0.760 hours

Subsection: Unit Hydrograph Summary
 Label: 302

Return Event: 100 years
 Storm Event: 100YR-24HR

Storm Event	100YR-24HR
Return Event	100 years
Duration	120.000 hours
Depth	8.6 in
Time of Concentration (Composite)	0.170 hours
Area (User Defined)	0.880 acres

Computational Time Increment	0.100 hours
Time to Peak (Computed)	16.000 hours
Flow (Peak, Computed)	0.46 ft ³ /s
Output Increment	0.100 hours
Time to Flow (Peak Interpolated Output)	16.000 hours
Flow (Peak Interpolated Output)	0.46 ft ³ /s

Drainage Area	
SCS CN (Composite)	61.870
Area (User Defined)	0.880 acres
Maximum Retention (Pervious)	6.2 in
Maximum Retention (Pervious, 20 percent)	1.2 in

Cumulative Runoff	
Cumulative Runoff Depth (Pervious)	4.0 in
Runoff Volume (Pervious)	0.292 ac-ft

Hydrograph Volume (Area under Hydrograph curve)	
Volume	0.292 ac-ft

SCS Unit Hydrograph Parameters	
Time of Concentration (Composite)	0.170 hours
Computational Time Increment	0.100 hours
Unit Hydrograph Shape Factor	483.432
K Factor	0.749
Receding/Rising, Tr/Tp	1.670
Unit peak, qp	4.37 ft ³ /s
Unit peak time, Tp	0.152 hours

Subsection: Unit Hydrograph Summary
Label: 302

Return Event: 100 years
Storm Event: 100YR-24HR

SCS Unit Hydrograph Parameters

Unit receding limb, Tr	0.608 hours
Total unit time, Tb	0.760 hours

Subsection: Unit Hydrograph Summary
 Label: 303

Return Event: 100 years
 Storm Event: 100YR-24HR

Storm Event	100YR-24HR
Return Event	100 years
Duration	120.000 hours
Depth	8.6 in
Time of Concentration (Composite)	0.170 hours
Area (User Defined)	1.970 acres

Computational Time Increment	0.100 hours
Time to Peak (Computed)	16.000 hours
Flow (Peak, Computed)	1.10 ft ³ /s
Output Increment	0.100 hours
Time to Flow (Peak Interpolated Output)	16.000 hours
Flow (Peak Interpolated Output)	1.10 ft ³ /s

Drainage Area	
SCS CN (Composite)	65.700
Area (User Defined)	1.970 acres
Maximum Retention (Pervious)	5.2 in
Maximum Retention (Pervious, 20 percent)	1.0 in

Cumulative Runoff	
Cumulative Runoff Depth (Pervious)	4.4 in
Runoff Volume (Pervious)	0.729 ac-ft

Hydrograph Volume (Area under Hydrograph curve)	
Volume	0.729 ac-ft

SCS Unit Hydrograph Parameters	
Time of Concentration (Composite)	0.170 hours
Computational Time Increment	0.100 hours
Unit Hydrograph Shape Factor	483.432
K Factor	0.749
Receding/Rising, Tr/Tp	1.670
Unit peak, qp	9.79 ft ³ /s
Unit peak time, Tp	0.152 hours

Subsection: Unit Hydrograph Summary
Label: 303

Return Event: 100 years
Storm Event: 100YR-24HR

SCS Unit Hydrograph Parameters

Unit receding limb, Tr	0.608 hours
Total unit time, Tb	0.760 hours

Subsection: Unit Hydrograph Summary
 Label: APN2

Return Event: 100 years
 Storm Event: 100YR-24HR

Storm Event	100YR-24HR
Return Event	100 years
Duration	120.000 hours
Depth	8.6 in
Time of Concentration (Composite)	0.250 hours
Area (User Defined)	10.160 acres

Computational Time Increment	0.100 hours
Time to Peak (Computed)	16.000 hours
Flow (Peak, Computed)	6.47 ft ³ /s
Output Increment	0.100 hours
Time to Flow (Peak Interpolated Output)	16.000 hours
Flow (Peak Interpolated Output)	6.47 ft ³ /s

Drainage Area	
SCS CN (Composite)	73.600
Area (User Defined)	10.160 acres
Maximum Retention (Pervious)	3.6 in
Maximum Retention (Pervious, 20 percent)	0.7 in

Cumulative Runoff	
Cumulative Runoff Depth (Pervious)	5.4 in
Runoff Volume (Pervious)	4.564 ac-ft

Hydrograph Volume (Area under Hydrograph curve)	
Volume	4.564 ac-ft

SCS Unit Hydrograph Parameters	
Time of Concentration (Composite)	0.250 hours
Computational Time Increment	0.100 hours
Unit Hydrograph Shape Factor	483.432
K Factor	0.749
Receding/Rising, Tr/Tp	1.670
Unit peak, qp	38.37 ft ³ /s
Unit peak time, Tp	0.200 hours

Subsection: Unit Hydrograph Summary
Label: APN2

Return Event: 100 years
Storm Event: 100YR-24HR

SCS Unit Hydrograph Parameters

Unit receding limb, Tr	0.800 hours
Total unit time, Tb	1.000 hours

Subsection: Unit Hydrograph Summary
 Label: APN3

Return Event: 100 years
 Storm Event: 100YR-24HR

Storm Event	100YR-24HR
Return Event	100 years
Duration	120.000 hours
Depth	8.6 in
Time of Concentration (Composite)	0.533 hours
Area (User Defined)	49.690 acres

Computational Time Increment	0.100 hours
Time to Peak (Computed)	16.000 hours
Flow (Peak, Computed)	35.60 ft ³ /s
Output Increment	0.100 hours
Time to Flow (Peak Interpolated Output)	16.000 hours
Flow (Peak Interpolated Output)	35.60 ft ³ /s

Drainage Area	
SCS CN (Composite)	84.500
Area (User Defined)	49.690 acres
Maximum Retention (Pervious)	1.8 in
Maximum Retention (Pervious, 20 percent)	0.4 in

Cumulative Runoff	
Cumulative Runoff Depth (Pervious)	6.7 in
Runoff Volume (Pervious)	27.760 ac-ft

Hydrograph Volume (Area under Hydrograph curve)	
Volume	27.760 ac-ft

SCS Unit Hydrograph Parameters	
Time of Concentration (Composite)	0.533 hours
Computational Time Increment	0.100 hours
Unit Hydrograph Shape Factor	483.432
K Factor	0.749
Receding/Rising, Tr/Tp	1.670
Unit peak, qp	101.50 ft ³ /s
Unit peak time, Tp	0.370 hours

Subsection: Unit Hydrograph Summary
Label: APN3

Return Event: 100 years
Storm Event: 100YR-24HR

SCS Unit Hydrograph Parameters

Unit receding limb, Tr	1.479 hours
Total unit time, Tb	1.849 hours

Subsection: Unit Hydrograph Summary
 Label: APN4

Return Event: 100 years
 Storm Event: 100YR-24HR

Storm Event	100YR-24HR
Return Event	100 years
Duration	120.000 hours
Depth	8.6 in
Time of Concentration (Composite)	0.543 hours
Area (User Defined)	17.440 acres

Computational Time Increment	0.100 hours
Time to Peak (Computed)	16.000 hours
Flow (Peak, Computed)	12.12 ft ³ /s
Output Increment	0.100 hours
Time to Flow (Peak Interpolated Output)	16.000 hours
Flow (Peak Interpolated Output)	12.12 ft ³ /s

Drainage Area	
SCS CN (Composite)	81.300
Area (User Defined)	17.440 acres
Maximum Retention (Pervious)	2.3 in
Maximum Retention (Pervious, 20 percent)	0.5 in

Cumulative Runoff	
Cumulative Runoff Depth (Pervious)	6.3 in
Runoff Volume (Pervious)	9.182 ac-ft

Hydrograph Volume (Area under Hydrograph curve)	
Volume	9.182 ac-ft

SCS Unit Hydrograph Parameters	
Time of Concentration (Composite)	0.543 hours
Computational Time Increment	0.100 hours
Unit Hydrograph Shape Factor	483.432
K Factor	0.749
Receding/Rising, Tr/Tp	1.670
Unit peak, qp	35.05 ft ³ /s
Unit peak time, Tp	0.376 hours

Subsection: Unit Hydrograph Summary
Label: APN4

Return Event: 100 years
Storm Event: 100YR-24HR

SCS Unit Hydrograph Parameters	
Unit receding limb, Tr	1.503 hours
Total unit time, Tb	1.879 hours

Subsection: Unit Hydrograph Summary
 Label: APN5

Return Event: 100 years
 Storm Event: 100YR-24HR

Storm Event	100YR-24HR
Return Event	100 years
Duration	120.000 hours
Depth	8.6 in
Time of Concentration (Composite)	0.595 hours
Area (User Defined)	40.530 acres

Computational Time Increment	0.100 hours
Time to Peak (Computed)	16.100 hours
Flow (Peak, Computed)	28.10 ft ³ /s
Output Increment	0.100 hours
Time to Flow (Peak Interpolated Output)	16.100 hours
Flow (Peak Interpolated Output)	28.10 ft ³ /s

Drainage Area	
SCS CN (Composite)	81.100
Area (User Defined)	40.530 acres
Maximum Retention (Pervious)	2.3 in
Maximum Retention (Pervious, 20 percent)	0.5 in

Cumulative Runoff	
Cumulative Runoff Depth (Pervious)	6.3 in
Runoff Volume (Pervious)	21.258 ac-ft

Hydrograph Volume (Area under Hydrograph curve)	
Volume	21.258 ac-ft

SCS Unit Hydrograph Parameters	
Time of Concentration (Composite)	0.595 hours
Computational Time Increment	0.100 hours
Unit Hydrograph Shape Factor	483.432
K Factor	0.749
Receding/Rising, Tr/Tp	1.670
Unit peak, qp	75.22 ft ³ /s
Unit peak time, Tp	0.407 hours

Subsection: Unit Hydrograph Summary
Label: APN5

Return Event: 100 years
Storm Event: 100YR-24HR

SCS Unit Hydrograph Parameters

Unit receding limb, Tr	1.628 hours
Total unit time, Tb	2.035 hours

Subsection: Unit Hydrograph Summary
 Label: APN6

Return Event: 100 years
 Storm Event: 100YR-24HR

Storm Event	100YR-24HR
Return Event	100 years
Duration	120.000 hours
Depth	8.6 in
Time of Concentration (Composite)	0.687 hours
Area (User Defined)	66.400 acres

Computational Time Increment	0.100 hours
Time to Peak (Computed)	16.100 hours
Flow (Peak, Computed)	42.34 ft ³ /s
Output Increment	0.100 hours
Time to Flow (Peak Interpolated Output)	16.100 hours
Flow (Peak Interpolated Output)	42.34 ft ³ /s

Drainage Area	
SCS CN (Composite)	74.400
Area (User Defined)	66.400 acres
Maximum Retention (Pervious)	3.4 in
Maximum Retention (Pervious, 20 percent)	0.7 in

Cumulative Runoff	
Cumulative Runoff Depth (Pervious)	5.5 in
Runoff Volume (Pervious)	30.359 ac-ft

Hydrograph Volume (Area under Hydrograph curve)	
Volume	30.359 ac-ft

SCS Unit Hydrograph Parameters	
Time of Concentration (Composite)	0.687 hours
Computational Time Increment	0.100 hours
Unit Hydrograph Shape Factor	483.432
K Factor	0.749
Receding/Rising, Tr/Tp	1.670
Unit peak, qp	108.52 ft ³ /s
Unit peak time, Tp	0.462 hours

Subsection: Unit Hydrograph Summary
Label: APN6

Return Event: 100 years
Storm Event: 100YR-24HR

SCS Unit Hydrograph Parameters

Unit receding limb, Tr	1.849 hours
Total unit time, Tb	2.311 hours

Subsection: Unit Hydrograph Summary
 Label: ASH4

Return Event: 100 years
 Storm Event: 100YR-24HR

Storm Event	100YR-24HR
Return Event	100 years
Duration	120.000 hours
Depth	8.6 in
Time of Concentration (Composite)	0.250 hours
Area (User Defined)	4.500 acres

Computational Time Increment	0.100 hours
Time to Peak (Computed)	16.000 hours
Flow (Peak, Computed)	3.15 ft ³ /s
Output Increment	0.100 hours
Time to Flow (Peak Interpolated Output)	16.000 hours
Flow (Peak Interpolated Output)	3.15 ft ³ /s

Drainage Area	
SCS CN (Composite)	81.600
Area (User Defined)	4.500 acres
Maximum Retention (Pervious)	2.3 in
Maximum Retention (Pervious, 20 percent)	0.5 in

Cumulative Runoff	
Cumulative Runoff Depth (Pervious)	6.4 in
Runoff Volume (Pervious)	2.383 ac-ft

Hydrograph Volume (Area under Hydrograph curve)	
Volume	2.383 ac-ft

SCS Unit Hydrograph Parameters	
Time of Concentration (Composite)	0.250 hours
Computational Time Increment	0.100 hours
Unit Hydrograph Shape Factor	483.432
K Factor	0.749
Receding/Rising, Tr/Tp	1.670
Unit peak, qp	17.00 ft ³ /s
Unit peak time, Tp	0.200 hours

Subsection: Unit Hydrograph Summary
Label: ASH4

Return Event: 100 years
Storm Event: 100YR-24HR

SCS Unit Hydrograph Parameters

Unit receding limb, Tr	0.800 hours
Total unit time, Tb	1.000 hours

Subsection: Read Hydrograph
 Label: CREEK OUTFALL 1

Return Event: 100 years
 Storm Event: 100YR-24HR

Peak Discharge	102.72 ft ³ /s
Time to Peak	21.400 hours
Hydrograph Volume	219.206 ac-ft

HYDROGRAPH ORDINATES (ft³/s)
Output Time Increment = 0.100 hours

Time on left represents time for first value in each row.

Time (hours)	Flow (ft ³ /s)	Flow (ft ³ /s)	Flow (ft ³ /s)	Flow (ft ³ /s)	Flow (ft ³ /s)
0.000	0.00	0.00	0.00	0.01	0.02
0.500	0.02	0.03	0.03	0.04	0.05
1.000	0.07	0.08	0.10	0.11	0.13
1.500	0.14	0.15	0.16	0.18	0.20
2.000	0.22	0.23	0.25	0.27	0.28
2.500	0.30	0.31	0.33	0.35	0.37
3.000	0.39	0.42	0.45	0.48	0.50
3.500	0.53	0.56	0.59	0.62	0.66
4.000	0.69	0.73	0.77	0.81	0.85
4.500	0.89	0.93	0.96	1.01	1.05
5.000	1.09	1.12	1.16	1.20	1.24
5.500	1.28	1.31	1.35	1.39	1.43
6.000	1.47	1.50	1.54	1.58	1.62
6.500	1.65	1.69	1.72	1.76	1.79
7.000	1.83	1.87	1.88	1.90	1.91
7.500	1.95	1.94	2.01	1.97	2.08
8.000	1.93	2.23	1.60	2.42	1.07
8.500	2.56	0.89	2.71	1.02	2.88
9.000	1.20	3.09	1.39	3.36	1.61
9.500	3.68	1.87	4.05	2.13	4.40
10.000	2.45	4.44	3.13	4.58	3.85
10.500	4.88	4.57	5.28	5.36	5.78
11.000	5.83	6.05	6.20	6.39	6.57
11.500	6.76	6.96	7.15	7.34	7.53
12.000	7.72	7.91	8.11	8.33	8.57
12.500	8.81	9.11	9.51	9.78	10.32
13.000	10.92	11.65	12.47	13.39	14.38
13.500	15.46	16.59	17.84	19.08	20.43
14.000	21.77	23.25	24.74	26.31	27.94
14.500	29.60	31.36	33.13	34.83	36.52
15.000	38.24	39.89	41.54	43.17	44.82
15.500	46.43	48.09	49.70	51.38	52.97
16.000	54.63	56.20	57.80	59.30	60.80
16.500	62.25	65.27	71.11	74.65	77.97
17.000	80.34	78.76	81.70	79.50	82.96
17.500	80.07	84.23	80.60	85.57	81.11
18.000	86.97	81.56	88.38	81.73	89.56
18.500	81.62	90.65	81.40	91.78	81.13
19.000	92.94	80.75	94.12	80.13	95.18

Subsection: Read Hydrograph
 Label: CREEK OUTFALL 1

Return Event: 100 years
 Storm Event: 100YR-24HR

HYDROGRAPH ORDINATES (ft³/s)
Output Time Increment = 0.100 hours
Time on left represents time for first value in each row.

Time (hours)	Flow (ft ³ /s)	Flow (ft ³ /s)	Flow (ft ³ /s)	Flow (ft ³ /s)	Flow (ft ³ /s)
19.500	79.27	96.19	78.29	97.27	77.19
20.000	98.36	76.12	99.41	74.93	100.30
20.500	73.55	101.04	72.25	101.67	71.09
21.000	102.25	70.06	102.59	69.28	102.72
21.500	68.67	102.72	68.20	102.65	67.86
22.000	102.55	67.59	102.44	67.37	102.29
22.500	67.17	102.10	67.04	101.91	66.94
23.000	101.71	66.86	101.52	66.77	101.33
23.500	66.66	101.14	66.56	100.95	66.46
24.000	100.77	66.36	100.53	66.06	100.06
24.500	65.63	99.44	65.29	98.75	64.96
25.000	98.08	64.64	97.40	64.39	96.72
25.500	64.21	96.03	64.02	95.36	63.77
26.000	94.72	63.53	94.07	63.35	93.41
26.500	63.20	92.74	63.05	92.09	62.93
27.000	88.97	66.43	84.01	70.79	78.46
27.500	72.35	74.68	72.24	72.39	71.29
28.000	70.85	70.09	69.50	68.87	68.31
28.500	67.76	67.24	66.73	66.24	65.76
29.000	65.28	64.81	64.33	63.86	63.38
29.500	62.91	62.67	62.59	62.43	62.30
30.000	62.14	61.98	61.82	61.64	61.47
30.500	61.29	61.12	60.95	60.76	60.58
31.000	60.39	60.20	60.01	59.82	59.63
31.500	59.43	59.23	59.03	58.84	58.66
32.000	58.48	58.29	58.10	57.90	57.71
32.500	57.51	57.30	57.09	56.88	56.68
33.000	56.49	56.30	56.11	55.92	55.72
33.500	55.52	55.31	55.09	54.85	54.60
34.000	54.35	54.11	53.88	53.66	53.45
34.500	53.23	53.01	52.76	52.50	52.22
35.000	51.94	51.67	51.40	51.14	50.88
35.500	50.64	50.41	50.16	49.91	49.64
36.000	49.38	49.09	48.81	48.54	48.27
36.500	48.02	47.79	47.56	47.32	47.05
37.000	46.76	46.47	46.20	45.93	45.67
37.500	45.42	45.19	44.96	44.72	44.46
38.000	44.18	43.89	43.61	43.34	43.09
38.500	42.86	42.64	42.43	42.21	41.98
39.000	41.72	41.46	41.19	40.92	40.65
39.500	40.40	40.15	39.93	39.74	39.56
40.000	39.36	39.13	38.86	38.57	38.28
40.500	38.00	37.74	37.49	37.26	37.05
41.000	36.84	36.61	36.36	36.09	35.79

Subsection: Read Hydrograph
 Label: CREEK OUTFALL 1

Return Event: 100 years
 Storm Event: 100YR-24HR

HYDROGRAPH ORDINATES (ft³/s)
Output Time Increment = 0.100 hours
Time on left represents time for first value in each row.

Time (hours)	Flow (ft ³ /s)	Flow (ft ³ /s)	Flow (ft ³ /s)	Flow (ft ³ /s)	Flow (ft ³ /s)
41.500	35.50	35.21	34.93	34.65	34.39
42.000	34.14	33.89	33.62	33.34	33.05
42.500	32.77	32.47	32.18	31.89	31.63
43.000	31.39	31.16	30.92	30.67	30.41
43.500	30.15	29.90	29.66	29.41	29.18
44.000	28.96	28.77	28.60	28.42	28.20
44.500	27.96	27.69	27.42	27.17	26.97
45.000	26.78	26.60	26.44	26.28	26.12
45.500	25.94	25.73	25.50	25.25	24.99
46.000	24.76	24.55	24.36	24.22	24.08
46.500	23.95	23.81	23.66	23.50	23.32
47.000	23.12	22.91	22.70	22.49	22.30
47.500	22.13	21.96	21.80	21.65	21.52
48.000	21.41	21.30	21.18	21.04	20.89
48.500	20.72	20.56	20.39	20.21	20.04
49.000	19.86	19.69	19.52	19.36	19.22
49.500	19.11	19.02	18.95	18.87	18.78
50.000	18.67	18.55	18.41	18.26	18.10
50.500	17.93	17.76	17.59	17.43	17.28
51.000	17.15	17.03	16.94	16.86	16.80
51.500	16.75	16.69	16.62	16.53	16.42
52.000	16.28	16.13	15.97	15.82	15.67
52.500	15.52	15.39	15.26	15.15	15.06
53.000	14.98	14.91	14.86	14.81	14.75
53.500	14.70	14.63	14.55	14.47	14.36
54.000	14.25	14.12	14.00	13.88	13.77
54.500	13.66	13.56	13.47	13.39	13.32
55.000	13.25	13.19	13.14	13.09	13.04
55.500	12.98	12.92	12.86	12.80	12.72
56.000	12.64	12.56	12.47	12.38	12.29
56.500	12.21	12.12	12.04	11.97	11.90
57.000	11.83	11.77	11.71	11.65	11.59
57.500	11.54	11.49	11.44	11.39	11.34
58.000	11.29	11.23	11.17	11.10	11.04
58.500	10.98	10.92	10.85	10.79	10.72
59.000	10.66	10.60	10.54	10.48	10.42
59.500	10.37	10.31	10.26	10.21	10.16
60.000	10.12	10.08	10.04	10.00	9.95
60.500	9.91	9.86	9.81	9.76	9.74
61.000	9.72	9.70	9.68	9.66	9.64
61.500	9.63	9.61	9.60	9.58	9.57
62.000	9.55	9.54	9.53	9.52	9.51
62.500	9.50	9.50	9.49	9.48	9.48
63.000	9.47	9.47	9.46	9.46	9.45

Subsection: Read Hydrograph
 Label: CREEK OUTFALL 1

Return Event: 100 years
 Storm Event: 100YR-24HR

HYDROGRAPH ORDINATES (ft³/s)
Output Time Increment = 0.100 hours
Time on left represents time for first value in each row.

Time (hours)	Flow (ft ³ /s)	Flow (ft ³ /s)	Flow (ft ³ /s)	Flow (ft ³ /s)	Flow (ft ³ /s)
63.500	9.45	9.44	9.44	9.43	9.42
64.000	9.42	9.41	9.40	9.40	9.39
64.500	9.38	9.37	9.36	9.35	9.34
65.000	9.34	9.33	9.32	9.31	9.30
65.500	9.30	9.29	9.28	9.28	9.27
66.000	9.26	9.26	9.25	9.24	9.24
66.500	9.23	9.23	9.22	9.22	9.21
67.000	9.21	9.21	9.20	9.20	9.19
67.500	9.19	9.19	9.18	9.18	9.18
68.000	9.17	9.17	9.17	9.16	9.16
68.500	9.16	9.15	9.15	9.15	9.14
69.000	9.14	9.14	9.14	9.13	9.13
69.500	9.13	9.12	9.12	9.12	9.12
70.000	9.11	9.11	9.11	9.11	9.10
70.500	9.10	9.10	9.10	9.09	9.09
71.000	9.09	9.09	9.08	9.08	9.08
71.500	9.08	9.07	9.07	9.07	9.06
72.000	9.06	9.06	9.06	9.05	9.05
72.500	9.05	9.05	9.05	9.04	9.04
73.000	9.04	9.04	9.03	9.03	9.03
73.500	9.03	9.03	9.40	9.47	9.53
74.000	9.58	9.62	9.65	9.69	9.73
74.500	9.77	9.83	9.89	9.94	9.99
75.000	10.03	10.08	10.12	10.04	9.91
75.500	9.75	9.65	9.58	9.52	9.46
76.000	9.42	9.38	9.35	9.32	9.29
76.500	9.27	9.25	9.23	9.22	9.21
77.000	9.20	9.19	9.18	9.17	9.16
77.500	9.16	9.15	9.14	9.13	9.13
78.000	9.12	9.11	9.11	9.10	9.10
78.500	9.09	9.09	9.08	9.08	9.07
79.000	9.07	9.06	9.06	9.05	9.05
79.500	9.04	9.04	9.03	9.03	9.03
80.000	9.02	9.02	9.01	9.01	9.00
80.500	9.00	8.99	8.99	8.98	8.98
81.000	8.97	8.97	8.96	8.95	8.95
81.500	8.94	8.94	8.93	8.93	8.93
82.000	8.92	8.91	8.91	8.90	8.89
82.500	8.89	8.88	8.87	8.87	8.86
83.000	8.85	8.84	8.84	8.83	8.82
83.500	8.81	8.81	8.80	8.79	8.78
84.000	8.78	8.77	8.76	8.75	8.75
84.500	8.74	8.73	8.73	8.72	8.71
85.000	8.71	8.70	8.69	8.69	8.68

Subsection: Read Hydrograph
 Label: CREEK OUTFALL 1

Return Event: 100 years
 Storm Event: 100YR-24HR

HYDROGRAPH ORDINATES (ft³/s)
Output Time Increment = 0.100 hours
Time on left represents time for first value in each row.

Time (hours)	Flow (ft ³ /s)	Flow (ft ³ /s)	Flow (ft ³ /s)	Flow (ft ³ /s)	Flow (ft ³ /s)
85.500	8.68	8.67	8.67	8.66	8.66
86.000	8.65	8.65	8.64	8.64	8.63
86.500	8.63	8.62	8.61	8.61	8.60
87.000	8.59	8.58	8.57	8.56	8.56
87.500	8.55	8.54	8.53	8.52	8.51
88.000	8.50	8.49	8.48	8.47	8.46
88.500	8.45	8.44	8.43	8.42	8.41
89.000	8.41	8.40	8.39	8.38	8.37
89.500	8.36	8.36	8.35	8.34	8.34
90.000	8.33	8.33	8.32	8.31	8.31
90.500	8.30	8.29	8.29	8.28	8.27
91.000	8.26	8.25	8.24	8.23	8.22
91.500	8.21	8.20	8.19	8.17	8.16
92.000	8.15	8.14	8.13	8.12	8.11
92.500	8.10	8.09	8.08	8.07	8.06
93.000	8.05	8.05	8.04	8.03	8.02
93.500	8.01	8.01	8.00	8.16	8.19
94.000	8.21	8.23	8.25	8.26	8.28
94.500	8.30	8.31	8.33	8.34	8.35
95.000	8.37	8.39	8.41	8.43	8.44
95.500	8.45	8.46	8.46	8.46	8.45
96.000	8.43	8.42	8.41	8.40	8.39
96.500	8.38	8.38	8.37	8.36	8.36
97.000	8.35	8.34	8.34	8.33	8.32
97.500	8.32	8.31	8.30	8.29	8.27
98.000	8.26	8.25	8.24	8.22	8.21
98.500	8.20	8.18	8.17	8.15	8.14
99.000	8.12	8.11	8.09	8.08	8.06
99.500	8.05	8.04	8.03	8.02	8.01
100.000	8.00	7.99	7.98	7.97	7.96
100.500	7.95	7.94	7.92	7.91	7.89
101.000	7.88	7.86	7.84	7.83	7.81
101.500	7.79	7.78	7.76	7.74	7.72
102.000	7.71	7.69	7.68	7.66	7.65
102.500	7.64	7.63	7.62	7.61	7.60
103.000	7.59	7.57	7.56	7.54	7.53
103.500	7.51	7.50	7.48	7.46	7.45
104.000	7.43	7.41	7.40	7.38	7.36
104.500	7.35	7.34	7.32	7.31	7.29
105.000	7.28	7.27	7.26	7.25	7.24
105.500	7.23	7.22	7.21	7.19	7.18
106.000	7.16	7.14	7.13	7.11	7.10
106.500	7.08	7.06	7.05	7.03	7.01
107.000	7.00	6.98	6.97	6.96	6.94

Subsection: Read Hydrograph
 Label: CREEK OUTFALL 1

Return Event: 100 years
 Storm Event: 100YR-24HR

HYDROGRAPH ORDINATES (ft³/s)
Output Time Increment = 0.100 hours
Time on left represents time for first value in each row.

Time (hours)	Flow (ft ³ /s)	Flow (ft ³ /s)	Flow (ft ³ /s)	Flow (ft ³ /s)	Flow (ft ³ /s)
107.500	6.93	6.92	6.91	6.90	6.89
108.000	6.88	6.87	6.86	6.84	6.83
108.500	6.82	6.80	6.79	6.77	6.76
109.000	6.74	6.73	6.71	6.69	6.68
109.500	6.66	6.65	6.63	6.61	6.60
110.000	6.58	6.57	6.56	6.54	6.53
110.500	6.52	6.51	6.50	6.49	6.48
111.000	6.47	6.46	6.44	6.43	6.41
111.500	6.40	6.38	6.36	6.35	6.33
112.000	6.31	6.30	6.28	6.26	6.24
112.500	6.23	6.21	6.19	6.18	6.38
113.000	6.39	6.43	6.46	6.49	6.52
113.500	6.54	6.56	6.59	6.61	6.64
114.000	6.66	6.69	6.70	6.72	6.73
114.500	6.73	6.73	6.73	6.73	6.72
115.000	6.72	6.71	6.71	6.71	6.70
115.500	6.70	6.69	6.69	6.68	6.68
116.000	6.67	6.66	6.65	6.64	6.62
116.500	6.61	6.59	6.58	6.56	6.55
117.000	6.54	6.52	6.51	6.50	6.48
117.500	6.47	6.45	6.43	6.41	6.39
118.000	6.37	6.35	6.32	6.30	6.28
118.500	6.25	6.23	6.21	6.19	6.16
119.000	6.15	6.13	6.11	6.10	6.08
119.500	6.06	6.05	6.03	6.01	5.98
120.000	5.96	(N/A)	(N/A)	(N/A)	(N/A)

Subsection: Read Hydrograph
 Label: CREEK OUTFALL 2

Return Event: 100 years
 Storm Event: 100YR-24HR

Peak Discharge	168.35 ft ³ /s
Time to Peak	0.100 hours
Hydrograph Volume	469.501 ac-ft

HYDROGRAPH ORDINATES (ft³/s)
Output Time Increment = 0.100 hours

Time on left represents time for first value in each row.

Time (hours)	Flow (ft ³ /s)	Flow (ft ³ /s)	Flow (ft ³ /s)	Flow (ft ³ /s)	Flow (ft ³ /s)
0.000	0.00	168.35	38.69	47.63	48.19
0.500	48.37	47.57	47.47	47.36	47.12
1.000	46.91	46.71	46.51	46.31	46.11
1.500	45.91	45.71	45.50	45.31	45.11
2.000	44.91	44.71	44.51	44.31	44.11
2.500	43.90	43.69	43.49	43.29	43.09
3.000	42.89	42.69	42.50	42.31	42.13
3.500	41.95	41.78	41.60	41.43	41.27
4.000	41.11	40.95	40.79	40.64	40.50
4.500	40.36	40.22	40.09	39.96	39.83
5.000	39.71	39.60	39.49	39.38	39.28
5.500	39.18	39.08	38.99	38.91	38.82
6.000	38.74	38.66	38.58	38.51	38.43
6.500	38.36	38.29	38.22	38.16	38.10
7.000	38.03	37.98	37.92	37.87	37.82
7.500	37.78	37.74	37.70	37.67	37.64
8.000	37.61	37.58	37.56	37.54	37.53
8.500	37.53	37.52	37.52	37.53	37.53
9.000	37.54	37.55	37.56	37.58	37.60
9.500	37.63	37.66	37.70	37.74	37.78
10.000	37.83	37.88	37.93	38.00	38.08
10.500	38.17	38.27	38.37	38.47	38.59
11.000	38.70	38.81	38.94	39.07	39.21
11.500	39.36	39.51	39.68	39.84	40.01
12.000	40.19	40.38	40.58	40.80	41.05
12.500	41.31	41.57	41.87	42.19	42.54
13.000	42.89	43.24	43.59	43.96	44.32
13.500	44.68	45.04	45.39	45.75	46.11
14.000	46.48	46.84	47.21	47.58	47.96
14.500	48.34	48.72	49.10	49.47	49.83
15.000	50.18	50.53	50.88	51.22	51.57
15.500	51.91	52.25	52.58	53.27	53.38
16.000	66.28	74.96	82.45	91.92	99.67
16.500	106.37	112.21	117.26	121.61	125.37
17.000	128.64	131.44	133.68	135.25	136.21
17.500	136.78	137.12	137.37	137.56	137.74
18.000	137.91	138.03	137.88	137.27	136.25
18.500	135.00	133.73	132.54	131.46	130.51
19.000	129.67	128.91	128.05	126.93	125.57

Subsection: Read Hydrograph
 Label: CREEK OUTFALL 2

Return Event: 100 years
 Storm Event: 100YR-24HR

HYDROGRAPH ORDINATES (ft³/s)
Output Time Increment = 0.100 hours
Time on left represents time for first value in each row.

Time (hours)	Flow (ft ³ /s)	Flow (ft ³ /s)	Flow (ft ³ /s)	Flow (ft ³ /s)	Flow (ft ³ /s)
19.500	124.11	122.69	121.38	120.19	119.13
20.000	118.20	117.34	116.42	115.32	114.04
20.500	112.70	111.40	110.20	109.11	108.12
21.000	107.25	106.45	105.68	104.85	103.99
21.500	103.12	102.30	101.55	100.86	100.24
22.000	99.69	99.19	98.71	98.22	97.73
22.500	97.26	96.82	96.43	96.07	95.75
23.000	95.49	95.24	95.01	94.78	94.56
23.500	94.35	94.16	93.99	93.83	93.68
24.000	93.55	93.39	93.02	92.30	91.26
24.500	90.07	88.85	87.68	86.59	85.58
25.000	84.69	83.88	83.17	82.53	81.96
25.500	81.55	81.20	80.87	80.57	80.29
26.000	80.02	79.77	79.53	79.29	79.06
26.500	78.83	78.62	78.41	78.20	78.00
27.000	77.79	77.59	77.39	77.19	76.99
27.500	76.80	76.61	76.42	76.25	76.07
28.000	75.90	75.74	75.58	75.42	75.26
28.500	75.11	74.96	74.81	74.66	74.52
29.000	74.38	74.25	74.11	73.98	73.85
29.500	73.72	73.59	73.46	73.32	73.18
30.000	73.03	72.86	72.68	72.50	72.30
30.500	72.09	71.87	71.65	71.42	71.18
31.000	70.94	70.69	70.44	70.18	69.93
31.500	69.67	69.40	69.14	68.87	68.60
32.000	68.33	68.06	67.78	67.51	67.23
32.500	66.96	66.68	66.40	66.12	65.69
33.000	65.02	64.15	63.17	62.09	61.31
33.500	60.60	59.84	59.05	58.24	57.42
34.000	56.59	55.51	54.19	52.97	52.79
34.500	52.74	52.67	52.61	52.54	52.48
35.000	52.41	52.35	52.28	52.22	52.15
35.500	52.09	52.02	51.96	51.89	51.82
36.000	51.76	51.69	51.63	51.56	51.49
36.500	51.43	51.36	51.30	51.23	51.17
37.000	51.10	51.04	50.97	50.91	50.84
37.500	50.78	50.71	50.65	50.58	50.52
38.000	50.45	50.39	50.33	50.26	50.20
38.500	50.14	50.08	50.01	49.95	49.89
39.000	49.83	49.77	49.71	49.65	49.59
39.500	49.53	49.47	49.41	49.35	49.28
40.000	49.22	49.16	49.10	49.04	48.98
40.500	48.92	48.86	48.80	48.74	48.68
41.000	48.62	48.56	48.50	48.44	48.38

Subsection: Read Hydrograph
 Label: CREEK OUTFALL 2

Return Event: 100 years
 Storm Event: 100YR-24HR

HYDROGRAPH ORDINATES (ft³/s)
Output Time Increment = 0.100 hours
Time on left represents time for first value in each row.

Time (hours)	Flow (ft ³ /s)	Flow (ft ³ /s)	Flow (ft ³ /s)	Flow (ft ³ /s)	Flow (ft ³ /s)
41.500	48.32	48.27	48.21	48.15	48.09
42.000	48.03	47.98	47.92	47.86	47.81
42.500	47.75	47.69	47.63	47.58	47.52
43.000	47.46	47.40	47.35	47.29	47.23
43.500	47.17	47.12	47.06	47.00	46.94
44.000	46.88	46.82	46.76	46.70	46.64
44.500	46.58	46.52	46.46	46.40	46.34
45.000	46.27	46.21	46.15	46.09	46.03
45.500	45.97	45.90	45.84	45.78	45.71
46.000	45.65	45.59	45.52	45.46	45.40
46.500	45.33	45.27	45.21	45.14	45.08
47.000	45.01	44.95	44.88	44.82	44.75
47.500	44.69	44.62	44.56	44.49	44.43
48.000	44.36	44.29	44.23	44.16	44.09
48.500	44.02	43.95	43.88	43.80	43.73
49.000	43.66	43.59	43.52	43.45	43.38
49.500	43.31	43.24	43.17	43.09	43.02
50.000	42.95	42.88	42.81	42.74	42.67
50.500	42.60	42.52	42.45	42.38	42.31
51.000	42.23	42.16	42.09	42.02	41.94
51.500	41.87	41.80	41.73	41.65	41.58
52.000	41.51	41.43	41.36	41.29	41.21
52.500	41.14	41.07	40.99	40.92	40.84
53.000	40.77	40.69	40.62	40.54	40.47
53.500	40.40	40.32	40.25	40.17	40.10
54.000	40.02	39.95	39.87	39.80	39.73
54.500	39.66	39.58	39.51	39.43	39.36
55.000	39.29	39.21	39.14	39.07	39.00
55.500	38.92	38.85	38.78	38.70	38.63
56.000	38.55	38.48	38.40	38.32	38.24
56.500	38.17	38.09	38.01	37.93	37.85
57.000	37.78	37.70	37.62	37.54	37.46
57.500	37.39	37.31	37.23	37.15	37.07
58.000	36.99	36.91	36.84	36.76	36.68
58.500	36.60	36.53	36.45	36.37	36.29
59.000	36.21	36.13	36.06	35.98	35.90
59.500	35.82	35.74	35.66	35.59	35.51
60.000	35.43	35.35	35.27	35.20	35.12
60.500	35.04	34.97	34.89	34.81	34.73
61.000	34.65	34.57	34.48	34.40	34.31
61.500	34.22	34.13	34.04	33.94	33.85
62.000	33.75	33.66	33.56	33.47	33.37
62.500	33.27	33.17	33.07	32.97	32.87
63.000	32.77	32.67	32.57	32.46	32.36

Subsection: Read Hydrograph
 Label: CREEK OUTFALL 2

Return Event: 100 years
 Storm Event: 100YR-24HR

HYDROGRAPH ORDINATES (ft³/s)
Output Time Increment = 0.100 hours
Time on left represents time for first value in each row.

Time (hours)	Flow (ft ³ /s)	Flow (ft ³ /s)	Flow (ft ³ /s)	Flow (ft ³ /s)	Flow (ft ³ /s)
63.500	32.26	32.15	32.05	31.94	31.83
64.000	31.72	31.61	31.50	31.39	31.28
64.500	31.16	31.05	30.94	30.83	30.71
65.000	30.59	30.48	30.36	30.25	30.13
65.500	30.01	29.90	29.78	29.66	29.54
66.000	29.42	29.31	29.19	29.07	28.95
66.500	28.82	28.70	28.58	28.45	28.33
67.000	28.21	28.09	27.97	27.84	27.72
67.500	27.60	27.48	27.35	27.23	27.11
68.000	26.99	26.86	26.74	26.62	26.50
68.500	26.38	26.26	26.14	26.01	25.89
69.000	25.77	25.64	25.52	25.40	25.28
69.500	25.16	25.04	24.92	24.80	24.68
70.000	24.56	24.44	24.32	24.20	24.08
70.500	23.95	23.83	23.71	23.59	23.47
71.000	23.35	23.23	23.11	22.99	22.87
71.500	22.75	22.63	22.51	22.39	22.28
72.000	22.16	22.05	21.92	21.80	21.68
72.500	21.55	21.43	21.31	21.19	21.08
73.000	20.96	21.32	21.50	21.78	22.05
73.500	165.84	151.45	40.21	52.85	51.80
74.000	51.32	51.08	51.02	50.83	50.63
74.500	50.46	50.29	50.11	49.93	49.76
75.000	49.59	49.41	49.23	49.05	48.88
75.500	48.72	48.56	48.41	48.26	48.11
76.000	47.96	47.81	47.65	47.50	47.35
76.500	47.20	47.05	46.90	46.74	46.59
77.000	46.44	46.29	46.13	45.98	45.83
77.500	45.67	45.52	45.37	45.22	45.06
78.000	44.91	44.76	44.60	44.45	44.30
78.500	44.14	43.97	43.81	43.64	43.48
79.000	43.32	43.16	42.99	42.83	42.66
79.500	42.50	42.34	42.17	42.01	41.85
80.000	41.68	41.52	41.35	41.19	41.03
80.500	40.86	40.70	40.53	40.37	40.21
81.000	40.04	39.88	39.72	39.56	39.40
81.500	39.24	39.08	38.92	38.75	38.59
82.000	38.43	38.26	38.09	37.92	37.76
82.500	37.59	37.42	37.25	37.09	36.92
83.000	36.75	36.59	36.42	36.25	36.09
83.500	35.92	35.76	35.59	35.43	35.26
84.000	35.10	34.94	34.77	34.61	34.45
84.500	34.29	34.12	33.96	33.80	33.64
85.000	33.48	33.32	33.16	33.00	32.84

Subsection: Read Hydrograph
 Label: CREEK OUTFALL 2

Return Event: 100 years
 Storm Event: 100YR-24HR

HYDROGRAPH ORDINATES (ft³/s)
Output Time Increment = 0.100 hours
Time on left represents time for first value in each row.

Time (hours)	Flow (ft ³ /s)	Flow (ft ³ /s)	Flow (ft ³ /s)	Flow (ft ³ /s)	Flow (ft ³ /s)
85.500	32.68	32.52	32.36	32.20	32.03
86.000	31.87	31.70	31.53	31.37	31.20
86.500	31.03	30.87	30.70	30.54	30.37
87.000	30.21	30.05	29.89	29.72	29.56
87.500	29.40	29.25	29.09	28.93	28.76
88.000	28.60	28.44	28.28	28.13	27.97
88.500	27.81	27.65	27.49	27.34	27.19
89.000	27.03	26.87	26.71	26.56	26.41
89.500	26.26	26.11	25.95	25.80	25.64
90.000	25.49	25.35	25.20	25.05	24.90
90.500	24.75	24.61	24.46	24.31	24.16
91.000	24.02	23.86	23.72	23.57	23.42
91.500	23.28	23.14	22.99	22.85	22.70
92.000	22.56	22.42	22.28	22.15	22.02
92.500	21.86	21.72	21.57	21.43	21.29
93.000	21.15	21.02	21.17	21.48	21.76
93.500	22.09	165.84	151.45	40.20	52.83
94.000	51.77	51.29	51.04	50.97	50.76
94.500	50.55	50.38	50.19	50.01	49.82
95.000	49.64	49.46	49.27	49.08	48.89
95.500	48.70	48.51	48.32	48.14	47.95
96.000	47.77	47.59	47.41	47.23	47.05
96.500	46.87	46.70	46.52	46.35	46.17
97.000	46.00	45.82	45.65	45.48	45.30
97.500	45.13	44.96	44.79	44.62	44.45
98.000	44.28	44.10	43.93	43.75	43.57
98.500	43.39	43.21	43.03	42.86	42.68
99.000	42.51	42.33	42.15	41.98	41.81
99.500	41.63	41.46	41.29	41.12	40.94
100.000	40.77	40.60	40.43	40.26	40.09
100.500	39.92	39.75	39.59	39.43	39.26
101.000	39.10	38.94	38.77	38.61	38.44
101.500	38.27	38.10	37.93	37.76	37.59
102.000	37.42	37.25	37.08	36.91	36.74
102.500	36.57	36.40	36.23	36.07	35.90
103.000	35.73	35.56	35.39	35.23	35.06
103.500	34.90	34.73	34.56	34.40	34.23
104.000	34.07	33.90	33.74	33.57	33.41
104.500	33.25	33.08	32.92	32.76	32.60
105.000	32.43	32.27	32.10	31.93	31.76
105.500	31.59	31.42	31.25	31.08	30.91
106.000	30.74	30.57	30.40	30.24	30.07
106.500	29.91	29.74	29.57	29.41	29.25
107.000	29.09	28.92	28.75	28.59	28.42

Subsection: Read Hydrograph
 Label: CREEK OUTFALL 2

Return Event: 100 years
 Storm Event: 100YR-24HR

HYDROGRAPH ORDINATES (ft³/s)
Output Time Increment = 0.100 hours
Time on left represents time for first value in each row.

Time (hours)	Flow (ft ³ /s)	Flow (ft ³ /s)	Flow (ft ³ /s)	Flow (ft ³ /s)	Flow (ft ³ /s)
107.500	28.26	28.10	27.94	27.77	27.61
108.000	27.45	27.29	27.13	26.97	26.81
108.500	26.65	26.49	26.33	26.18	26.02
109.000	25.86	25.70	25.55	25.39	25.24
109.500	25.09	24.93	24.78	24.63	24.47
110.000	24.32	24.17	24.01	23.86	23.70
110.500	23.55	23.40	23.25	23.11	22.95
111.000	22.80	22.65	22.51	22.36	22.22
111.500	22.08	21.93	21.77	21.63	21.48
112.000	21.33	21.18	21.04	21.11	21.47
112.500	21.74	22.09	165.84	151.45	40.19
113.000	52.83	51.76	51.27	51.02	50.95
113.500	50.74	50.53	50.35	50.16	49.97
114.000	49.78	49.60	49.41	49.22	49.02
114.500	48.82	48.63	48.44	48.24	48.05
115.000	47.85	47.66	47.47	47.28	47.09
115.500	46.89	46.70	46.51	46.32	46.13
116.000	45.95	45.76	45.57	45.39	45.21
116.500	45.03	44.85	44.67	44.49	44.31
117.000	44.13	43.95	43.76	43.58	43.39
117.500	43.21	43.03	42.85	42.66	42.49
118.000	42.30	42.12	41.95	41.77	41.59
118.500	41.41	41.23	41.06	40.88	40.70
119.000	40.53	40.36	40.18	40.01	39.83
119.500	39.67	39.50	39.33	39.16	38.99
120.000	38.83	(N/A)	(N/A)	(N/A)	(N/A)

Subsection: Unit Hydrograph Summary
 Label: PR1

Return Event: 100 years
 Storm Event: 100YR-24HR

Storm Event	100YR-24HR
Return Event	100 years
Duration	120.000 hours
Depth	8.6 in
Time of Concentration (Composite)	0.250 hours
Area (User Defined)	19.700 acres

Computational Time Increment	0.100 hours
Time to Peak (Computed)	16.000 hours
Flow (Peak, Computed)	13.93 ft ³ /s
Output Increment	0.100 hours
Time to Flow (Peak Interpolated Output)	16.000 hours
Flow (Peak Interpolated Output)	13.93 ft ³ /s

Drainage Area	
SCS CN (Composite)	82.600
Area (User Defined)	19.700 acres
Maximum Retention (Pervious)	2.1 in
Maximum Retention (Pervious, 20 percent)	0.4 in

Cumulative Runoff	
Cumulative Runoff Depth (Pervious)	6.5 in
Runoff Volume (Pervious)	10.630 ac-ft

Hydrograph Volume (Area under Hydrograph curve)	
Volume	10.630 ac-ft

SCS Unit Hydrograph Parameters	
Time of Concentration (Composite)	0.250 hours
Computational Time Increment	0.100 hours
Unit Hydrograph Shape Factor	483.432
K Factor	0.749
Receding/Rising, Tr/Tp	1.670
Unit peak, qp	74.40 ft ³ /s
Unit peak time, Tp	0.200 hours

Subsection: Unit Hydrograph Summary
Label: PR1

Return Event: 100 years
Storm Event: 100YR-24HR

SCS Unit Hydrograph Parameters

Unit receding limb, Tr	0.800 hours
Total unit time, Tb	1.000 hours

Subsection: Unit Hydrograph Summary
 Label: PR2

Return Event: 100 years
 Storm Event: 100YR-24HR

Storm Event	100YR-24HR
Return Event	100 years
Duration	120.000 hours
Depth	8.6 in
Time of Concentration (Composite)	0.250 hours
Area (User Defined)	9.710 acres

Computational Time Increment	0.100 hours
Time to Peak (Computed)	16.000 hours
Flow (Peak, Computed)	6.87 ft ³ /s
Output Increment	0.100 hours
Time to Flow (Peak Interpolated Output)	16.000 hours
Flow (Peak Interpolated Output)	6.87 ft ³ /s

Drainage Area	
SCS CN (Composite)	82.600
Area (User Defined)	9.710 acres
Maximum Retention (Pervious)	2.1 in
Maximum Retention (Pervious, 20 percent)	0.4 in

Cumulative Runoff	
Cumulative Runoff Depth (Pervious)	6.5 in
Runoff Volume (Pervious)	5.239 ac-ft

Hydrograph Volume (Area under Hydrograph curve)	
Volume	5.239 ac-ft

SCS Unit Hydrograph Parameters	
Time of Concentration (Composite)	0.250 hours
Computational Time Increment	0.100 hours
Unit Hydrograph Shape Factor	483.432
K Factor	0.749
Receding/Rising, Tr/Tp	1.670
Unit peak, qp	36.67 ft ³ /s
Unit peak time, Tp	0.200 hours

Subsection: Unit Hydrograph Summary
Label: PR2

Return Event: 100 years
Storm Event: 100YR-24HR

SCS Unit Hydrograph Parameters

Unit receding limb, Tr	0.800 hours
Total unit time, Tb	1.000 hours

Subsection: Unit Hydrograph Summary
 Label: PR3

Return Event: 100 years
 Storm Event: 100YR-24HR

Storm Event	100YR-24HR
Return Event	100 years
Duration	120.000 hours
Depth	8.6 in
Time of Concentration (Composite)	0.250 hours
Area (User Defined)	5.830 acres

Computational Time Increment	0.100 hours
Time to Peak (Computed)	16.000 hours
Flow (Peak, Computed)	4.12 ft ³ /s
Output Increment	0.100 hours
Time to Flow (Peak Interpolated Output)	16.000 hours
Flow (Peak Interpolated Output)	4.12 ft ³ /s

Drainage Area	
SCS CN (Composite)	82.600
Area (User Defined)	5.830 acres
Maximum Retention (Pervious)	2.1 in
Maximum Retention (Pervious, 20 percent)	0.4 in

Cumulative Runoff	
Cumulative Runoff Depth (Pervious)	6.5 in
Runoff Volume (Pervious)	3.146 ac-ft

Hydrograph Volume (Area under Hydrograph curve)	
Volume	3.146 ac-ft

SCS Unit Hydrograph Parameters	
Time of Concentration (Composite)	0.250 hours
Computational Time Increment	0.100 hours
Unit Hydrograph Shape Factor	483.432
K Factor	0.749
Receding/Rising, Tr/Tp	1.670
Unit peak, qp	22.02 ft ³ /s
Unit peak time, Tp	0.200 hours

Subsection: Unit Hydrograph Summary
Label: PR3

Return Event: 100 years
Storm Event: 100YR-24HR

SCS Unit Hydrograph Parameters

Unit receding limb, Tr	0.800 hours
Total unit time, Tb	1.000 hours

Subsection: Unit Hydrograph Summary
 Label: TAM1

Return Event: 100 years
 Storm Event: 100YR-24HR

Storm Event	100YR-24HR
Return Event	100 years
Duration	120.000 hours
Depth	8.6 in
Time of Concentration (Composite)	0.476 hours
Area (User Defined)	140.350 acres

Computational Time Increment	0.100 hours
Time to Peak (Computed)	16.000 hours
Flow (Peak, Computed)	96.74 ft ³ /s
Output Increment	0.100 hours
Time to Flow (Peak Interpolated Output)	16.000 hours
Flow (Peak Interpolated Output)	96.74 ft ³ /s

Drainage Area	
SCS CN (Composite)	80.400
Area (User Defined)	140.350 acres
Maximum Retention (Pervious)	2.4 in
Maximum Retention (Pervious, 20 percent)	0.5 in

Cumulative Runoff	
Cumulative Runoff Depth (Pervious)	6.2 in
Runoff Volume (Pervious)	72.626 ac-ft

Hydrograph Volume (Area under Hydrograph curve)	
Volume	72.626 ac-ft

SCS Unit Hydrograph Parameters	
Time of Concentration (Composite)	0.476 hours
Computational Time Increment	0.100 hours
Unit Hydrograph Shape Factor	483.432
K Factor	0.749
Receding/Rising, Tr/Tp	1.670
Unit peak, qp	315.90 ft ³ /s
Unit peak time, Tp	0.336 hours

Subsection: Unit Hydrograph Summary
Label: TAM1

Return Event: 100 years
Storm Event: 100YR-24HR

SCS Unit Hydrograph Parameters

Unit receding limb, Tr	1.342 hours
Total unit time, Tb	1.678 hours

Subsection: Unit Hydrograph Summary
 Label: TAM2

Return Event: 100 years
 Storm Event: 100YR-24HR

Storm Event	100YR-24HR
Return Event	100 years
Duration	120.000 hours
Depth	8.6 in
Time of Concentration (Composite)	0.229 hours
Area (User Defined)	6.720 acres

Computational Time Increment	0.100 hours
Time to Peak (Computed)	16.000 hours
Flow (Peak, Computed)	4.82 ft ³ /s
Output Increment	0.100 hours
Time to Flow (Peak Interpolated Output)	16.000 hours
Flow (Peak Interpolated Output)	4.82 ft ³ /s

Drainage Area	
SCS CN (Composite)	84.100
Area (User Defined)	6.720 acres
Maximum Retention (Pervious)	1.9 in
Maximum Retention (Pervious, 20 percent)	0.4 in

Cumulative Runoff	
Cumulative Runoff Depth (Pervious)	6.7 in
Runoff Volume (Pervious)	3.727 ac-ft

Hydrograph Volume (Area under Hydrograph curve)	
Volume	3.727 ac-ft

SCS Unit Hydrograph Parameters	
Time of Concentration (Composite)	0.229 hours
Computational Time Increment	0.100 hours
Unit Hydrograph Shape Factor	483.432
K Factor	0.749
Receding/Rising, Tr/Tp	1.670
Unit peak, qp	27.09 ft ³ /s
Unit peak time, Tp	0.187 hours

Subsection: Unit Hydrograph Summary
Label: TAM2

Return Event: 100 years
Storm Event: 100YR-24HR

SCS Unit Hydrograph Parameters

Unit receding limb, Tr	0.750 hours
Total unit time, Tb	0.937 hours

Subsection: Unit Hydrograph Summary
 Label: TAM3

Return Event: 100 years
 Storm Event: 100YR-24HR

Storm Event	100YR-24HR
Return Event	100 years
Duration	120.000 hours
Depth	8.6 in
Time of Concentration (Composite)	0.320 hours
Area (User Defined)	10.130 acres

Computational Time Increment	0.100 hours
Time to Peak (Computed)	16.000 hours
Flow (Peak, Computed)	7.19 ft ³ /s
Output Increment	0.100 hours
Time to Flow (Peak Interpolated Output)	16.000 hours
Flow (Peak Interpolated Output)	7.19 ft ³ /s

Drainage Area	
SCS CN (Composite)	83.200
Area (User Defined)	10.130 acres
Maximum Retention (Pervious)	2.0 in
Maximum Retention (Pervious, 20 percent)	0.4 in

Cumulative Runoff	
Cumulative Runoff Depth (Pervious)	6.5 in
Runoff Volume (Pervious)	5.527 ac-ft

Hydrograph Volume (Area under Hydrograph curve)	
Volume	5.527 ac-ft

SCS Unit Hydrograph Parameters	
Time of Concentration (Composite)	0.320 hours
Computational Time Increment	0.100 hours
Unit Hydrograph Shape Factor	483.432
K Factor	0.749
Receding/Rising, Tr/Tp	1.670
Unit peak, qp	31.62 ft ³ /s
Unit peak time, Tp	0.242 hours

Subsection: Unit Hydrograph Summary
Label: TAM3

Return Event: 100 years
Storm Event: 100YR-24HR

SCS Unit Hydrograph Parameters	
Unit receding limb, Tr	0.968 hours
Total unit time, Tb	1.210 hours

Subsection: Unit Hydrograph Summary
 Label: TAM4

Return Event: 100 years
 Storm Event: 100YR-24HR

Storm Event	100YR-24HR
Return Event	100 years
Duration	120.000 hours
Depth	8.6 in
Time of Concentration (Composite)	0.720 hours
Area (User Defined)	60.500 acres

Computational Time Increment	0.100 hours
Time to Peak (Computed)	16.100 hours
Flow (Peak, Computed)	42.56 ft ³ /s
Output Increment	0.100 hours
Time to Flow (Peak Interpolated Output)	16.100 hours
Flow (Peak Interpolated Output)	42.56 ft ³ /s

Drainage Area	
SCS CN (Composite)	82.700
Area (User Defined)	60.500 acres
Maximum Retention (Pervious)	2.1 in
Maximum Retention (Pervious, 20 percent)	0.4 in

Cumulative Runoff	
Cumulative Runoff Depth (Pervious)	6.5 in
Runoff Volume (Pervious)	32.705 ac-ft

Hydrograph Volume (Area under Hydrograph curve)	
Volume	32.705 ac-ft

SCS Unit Hydrograph Parameters	
Time of Concentration (Composite)	0.720 hours
Computational Time Increment	0.100 hours
Unit Hydrograph Shape Factor	483.432
K Factor	0.749
Receding/Rising, Tr/Tp	1.670
Unit peak, qp	94.81 ft ³ /s
Unit peak time, Tp	0.482 hours

Subsection: Unit Hydrograph Summary
Label: TAM4

Return Event: 100 years
Storm Event: 100YR-24HR

SCS Unit Hydrograph Parameters

Unit receding limb, Tr	1.928 hours
Total unit time, Tb	2.410 hours

Subsection: Unit Hydrograph Summary
 Label: TAM5

Return Event: 100 years
 Storm Event: 100YR-24HR

Storm Event	100YR-24HR
Return Event	100 years
Duration	120.000 hours
Depth	8.6 in
Time of Concentration (Composite)	0.407 hours
Area (User Defined)	8.840 acres

Computational Time Increment	0.100 hours
Time to Peak (Computed)	16.000 hours
Flow (Peak, Computed)	6.45 ft ³ /s
Output Increment	0.100 hours
Time to Flow (Peak Interpolated Output)	16.000 hours
Flow (Peak Interpolated Output)	6.45 ft ³ /s

Drainage Area	
SCS CN (Composite)	86.700
Area (User Defined)	8.840 acres
Maximum Retention (Pervious)	1.5 in
Maximum Retention (Pervious, 20 percent)	0.3 in

Cumulative Runoff	
Cumulative Runoff Depth (Pervious)	7.0 in
Runoff Volume (Pervious)	5.134 ac-ft

Hydrograph Volume (Area under Hydrograph curve)	
Volume	5.134 ac-ft

SCS Unit Hydrograph Parameters	
Time of Concentration (Composite)	0.407 hours
Computational Time Increment	0.100 hours
Unit Hydrograph Shape Factor	483.432
K Factor	0.749
Receding/Rising, Tr/Tp	1.670
Unit peak, qp	22.70 ft ³ /s
Unit peak time, Tp	0.294 hours

Subsection: Unit Hydrograph Summary
Label: TAM5

Return Event: 100 years
Storm Event: 100YR-24HR

SCS Unit Hydrograph Parameters

Unit receding limb, Tr	1.177 hours
Total unit time, Tb	1.471 hours

Subsection: Unit Hydrograph Summary
 Label: TAM6

Return Event: 100 years
 Storm Event: 100YR-24HR

Storm Event	100YR-24HR
Return Event	100 years
Duration	120.000 hours
Depth	8.6 in
Time of Concentration (Composite)	0.338 hours
Area (User Defined)	25.630 acres

Computational Time Increment	0.100 hours
Time to Peak (Computed)	16.000 hours
Flow (Peak, Computed)	16.35 ft ³ /s
Output Increment	0.100 hours
Time to Flow (Peak Interpolated Output)	16.000 hours
Flow (Peak Interpolated Output)	16.35 ft ³ /s

Drainage Area	
SCS CN (Composite)	73.900
Area (User Defined)	25.630 acres
Maximum Retention (Pervious)	3.5 in
Maximum Retention (Pervious, 20 percent)	0.7 in

Cumulative Runoff	
Cumulative Runoff Depth (Pervious)	5.4 in
Runoff Volume (Pervious)	11.590 ac-ft

Hydrograph Volume (Area under Hydrograph curve)	
Volume	11.590 ac-ft

SCS Unit Hydrograph Parameters	
Time of Concentration (Composite)	0.338 hours
Computational Time Increment	0.100 hours
Unit Hydrograph Shape Factor	483.432
K Factor	0.749
Receding/Rising, Tr/Tp	1.670
Unit peak, qp	76.58 ft ³ /s
Unit peak time, Tp	0.253 hours

Subsection: Unit Hydrograph Summary
Label: TAM6

Return Event: 100 years
Storm Event: 100YR-24HR

SCS Unit Hydrograph Parameters

Unit receding limb, Tr	1.011 hours
Total unit time, Tb	1.264 hours

Subsection: Unit Hydrograph Summary
 Label: TAM7

Return Event: 100 years
 Storm Event: 100YR-24HR

Storm Event	100YR-24HR
Return Event	100 years
Duration	120.000 hours
Depth	8.6 in
Time of Concentration (Composite)	0.649 hours
Area (User Defined)	74.300 acres

Computational Time Increment	0.100 hours
Time to Peak (Computed)	16.100 hours
Flow (Peak, Computed)	50.65 ft ³ /s
Output Increment	0.100 hours
Time to Flow (Peak Interpolated Output)	16.100 hours
Flow (Peak Interpolated Output)	50.65 ft ³ /s

Drainage Area	
SCS CN (Composite)	79.600
Area (User Defined)	74.300 acres
Maximum Retention (Pervious)	2.6 in
Maximum Retention (Pervious, 20 percent)	0.5 in

Cumulative Runoff	
Cumulative Runoff Depth (Pervious)	6.1 in
Runoff Volume (Pervious)	37.850 ac-ft

Hydrograph Volume (Area under Hydrograph curve)	
Volume	37.850 ac-ft

SCS Unit Hydrograph Parameters	
Time of Concentration (Composite)	0.649 hours
Computational Time Increment	0.100 hours
Unit Hydrograph Shape Factor	483.432
K Factor	0.749
Receding/Rising, Tr/Tp	1.670
Unit peak, qp	127.73 ft ³ /s
Unit peak time, Tp	0.439 hours

Subsection: Unit Hydrograph Summary
Label: TAM7

Return Event: 100 years
Storm Event: 100YR-24HR

SCS Unit Hydrograph Parameters

Unit receding limb, Tr	1.758 hours
Total unit time, Tb	2.197 hours

Subsection: Elevation vs. Volume Curve
Label: APN3

Return Event: 100 years
Storm Event: 100YR-24HR

Elevation-Volume

Pond Elevation (ft)	Pond Volume (ac-ft)
680.00	0.000
681.00	2.633
682.00	5.528
683.00	8.586
684.00	11.815
685.00	15.256
685.80	18.207
686.00	18.979
687.00	23.049

Subsection: Elevation vs. Volume Curve
Label: APN4

Return Event: 100 years
Storm Event: 100YR-24HR

Elevation-Volume

Pond Elevation (ft)	Pond Volume (ac-ft)
680.20	0.000
682.00	1.096
684.00	2.577
686.00	4.611
688.00	7.610

Subsection: Elevation vs. Volume Curve
Label: APN5

Return Event: 100 years
Storm Event: 100YR-24HR

Elevation-Volume

Pond Elevation (ft)	Pond Volume (ac-ft)
676.90	0.000
678.00	1.610
680.00	5.298
682.00	10.085

Subsection: Elevation vs. Volume Curve
Label: APN6

Return Event: 100 years
Storm Event: 100YR-24HR

Elevation-Volume

Pond Elevation (ft)	Pond Volume (ac-ft)
667.50	0.000
668.00	2.622
670.00	13.345
672.00	23.978
674.00	38.438

Subsection: Elevation vs. Volume Curve
Label: North Pond

Return Event: 100 years
Storm Event: 100YR-24HR

Elevation-Volume

Pond Elevation (ft)	Pond Volume (ac-ft)
649.00	0.000
649.70	0.074
650.00	0.120
651.00	0.317
652.00	0.571
653.00	0.887
654.00	1.273
655.00	1.735

Subsection: Elevation vs. Volume Curve
Label: South Pond

Return Event: 100 years
Storm Event: 100YR-24HR

Elevation-Volume

Pond Elevation (ft)	Pond Volume (ac-ft)
650.00	0.000
650.30	0.264
651.00	1.126
652.00	2.483
653.00	4.003
654.00	5.692
654.50	6.601
655.00	7.554

Subsection: Elevation vs. Volume Curve
Label: TAM1

Return Event: 100 years
Storm Event: 100YR-24HR

Elevation-Volume

Pond Elevation (ft)	Pond Volume (ac-ft)
659.00	0.000
660.00	3.402
661.00	7.246
662.00	11.543
664.00	22.246
666.00	36.781
668.00	60.318

Subsection: Elevation vs. Volume Curve
Label: TAM2

Return Event: 100 years
Storm Event: 100YR-24HR

Elevation-Volume

Pond Elevation (ft)	Pond Volume (ac-ft)
662.40	0.000
664.00	1.196
666.00	3.102
668.00	5.660

Subsection: Elevation vs. Volume Curve
Label: TAM3

Return Event: 100 years
Storm Event: 100YR-24HR

Elevation-Volume

Pond Elevation (ft)	Pond Volume (ac-ft)
661.50	0.000
662.00	0.460
664.00	2.672
666.00	5.510
668.00	9.258

Subsection: Elevation vs. Volume Curve
Label: TAM4

Return Event: 100 years
Storm Event: 100YR-24HR

Elevation-Volume

Pond Elevation (ft)	Pond Volume (ac-ft)
660.00	0.000
662.00	7.246
664.00	15.270
666.00	24.411

Subsection: Elevation vs. Volume Curve
Label: TAM5

Return Event: 100 years
Storm Event: 100YR-24HR

Elevation-Volume

Pond Elevation (ft)	Pond Volume (ac-ft)
657.00	0.000
658.00	1.413
660.00	4.701
662.00	8.592

Subsection: Elevation vs. Volume Curve
Label: TAM6

Return Event: 100 years
Storm Event: 100YR-24HR

Elevation-Volume

Pond Elevation (ft)	Pond Volume (ac-ft)
653.00	0.000
654.00	0.257
656.00	1.110
658.00	4.651
660.00	11.414
662.00	20.228

Subsection: Elevation vs. Volume Curve
Label: TAM7

Return Event: 100 years
Storm Event: 100YR-24HR

Elevation-Volume

Pond Elevation (ft)	Pond Volume (ac-ft)
650.00	0.000
652.00	5.146
654.00	11.134
656.00	18.412
658.00	29.988

Subsection: Elevation vs. Volume Curve
Label: West Tributary - Clow Creek

Return Event: 100 years
Storm Event: 100YR-24HR

Elevation-Volume

Pond Elevation (ft)	Pond Volume (ac-ft)
647.00	0.000
648.00	0.012
649.00	0.036
650.00	0.169
651.00	0.438
652.00	0.767
653.00	1.944
654.00	5.617
655.00	12.280

Subsection: Outlet Input Data
 Label: APN3 Outlet

Return Event: 100 years
 Storm Event: 100YR-24HR

Requested Pond Water Surface Elevations	
Minimum (Headwater)	680.00 ft
Increment (Headwater)	0.10 ft
Maximum (Headwater)	687.00 ft

Outlet Connectivity

Structure Type	Outlet ID	Direction	Outfall	E1 (ft)	E2 (ft)
Culvert-Circular	Culvert - 1	Forward + Reverse	TW	681.80	687.00
Culvert-Circular	Culvert - 2	Forward + Reverse	TW	680.00	681.80
Irregular Weir	Weir - 1	Forward + Reverse	TW	686.10	687.00
Tailwater Settings	Tailwater			(N/A)	(N/A)

Subsection: Outlet Input Data
 Label: APN3 Outlet

Return Event: 100 years
 Storm Event: 100YR-24HR

Structure ID: Culvert - 1	
Structure Type: Culvert-Circular	
Number of Barrels	1
Diameter	15.0 in
Length	109.00 ft
Length (Computed Barrel)	109.00 ft
Slope (Computed)	0.008 ft/ft
Outlet Control Data	
Manning's n	0.013
Ke	0.200
Kb	0.023
Kr	0.000
Convergence Tolerance	0.00 ft
Inlet Control Data	
Equation Form	Form 1
K	0.0045
M	2.0000
C	0.0317
Y	0.6900
T1 ratio (HW/D)	1.091
T2 ratio (HW/D)	1.193
Slope Correction Factor	-0.500

Use unsubmerged inlet control 0 equation below T1 elevation.
 Use submerged inlet control 0 equation above T2 elevation

In transition zone between unsubmerged and submerged inlet control, interpolate between flows at T1 & T2...

T1 Elevation	678.32 ft	T1 Flow	4.80 ft ³ /s
T2 Elevation	678.45 ft	T2 Flow	5.49 ft ³ /s

Subsection: Outlet Input Data
 Label: APN3 Outlet

Return Event: 100 years
 Storm Event: 100YR-24HR

Structure ID: Culvert - 2	
Structure Type: Culvert-Circular	
Number of Barrels	1
Diameter	24.0 in
Length	376.00 ft
Length (Computed Barrel)	376.01 ft
Slope (Computed)	0.008 ft/ft
Outlet Control Data	
Manning's n	0.013
Ke	0.200
Kb	0.012
Kr	0.000
Convergence Tolerance	0.00 ft
Inlet Control Data	
Equation Form	Form 1
K	0.0045
M	2.0000
C	0.0317
Y	0.6900
T1 ratio (HW/D)	1.091
T2 ratio (HW/D)	1.193
Slope Correction Factor	-0.500

Use unsubmerged inlet control 0 equation below T1 elevation.

Use submerged inlet control 0 equation above T2 elevation

In transition zone between unsubmerged and submerged inlet control, interpolate between flows at T1 & T2...

T1 Elevation	682.18 ft	T1 Flow	15.55 ft ³ /s
T2 Elevation	682.39 ft	T2 Flow	17.77 ft ³ /s

Subsection: Outlet Input Data
Label: APN3 Outlet

Return Event: 100 years
Storm Event: 100YR-24HR

Structure ID: Weir - 1
Structure Type: Irregular Weir

Station (ft)	Elevation (ft)
0.00	687.00
15.00	686.10
55.00	686.40
120.00	687.00

Lowest Elevation 686.10 ft
Weir Coefficient 3.00 (ft^{0.5})/s

Subsection: Outlet Input Data
 Label: APN4 Outlet

Return Event: 100 years
 Storm Event: 100YR-24HR

Requested Pond Water Surface Elevations	
Minimum (Headwater)	680.20 ft
Increment (Headwater)	0.10 ft
Maximum (Headwater)	688.00 ft

Outlet Connectivity

Structure Type	Outlet ID	Direction	Outfall	E1 (ft)	E2 (ft)
Culvert-Circular	Culvert - 1	Forward + Reverse	TW	680.20	688.00
Rectangular Weir	Weir - 1	Forward + Reverse	TW	686.50	688.00
Tailwater Settings	Tailwater			(N/A)	(N/A)

Subsection: Outlet Input Data
 Label: APN4 Outlet

Return Event: 100 years
 Storm Event: 100YR-24HR

Structure ID: Culvert - 1	
Structure Type: Culvert-Circular	
Number of Barrels	1
Diameter	12.0 in
Length	368.00 ft
Length (Computed Barrel)	368.01 ft
Slope (Computed)	0.007 ft/ft
Outlet Control Data	
Manning's n	0.013
Ke	0.200
Kb	0.031
Kr	0.000
Convergence Tolerance	0.00 ft
Inlet Control Data	
Equation Form	Form 1
K	0.0045
M	2.0000
C	0.0317
Y	0.6900
T1 ratio (HW/D)	1.092
T2 ratio (HW/D)	1.194
Slope Correction Factor	-0.500

Use unsubmerged inlet control 0 equation below T1 elevation.

Use submerged inlet control 0 equation above T2 elevation

In transition zone between unsubmerged and submerged inlet control, interpolate between flows at T1 & T2...

T1 Elevation	681.29 ft	T1 Flow	2.75 ft ³ /s
T2 Elevation	681.39 ft	T2 Flow	3.14 ft ³ /s

Subsection: Outlet Input Data
Label: APN4 Outlet

Return Event: 100 years
Storm Event: 100YR-24HR

Structure ID: Weir - 1	
Structure Type: Rectangular Weir	
<hr/>	
Number of Openings	1
Elevation	686.50 ft
Weir Length	34.00 ft
Weir Coefficient	3.00 (ft ^{0.5})/s

Subsection: Outlet Input Data
 Label: APN5

Return Event: 100 years
 Storm Event: 100YR-24HR

Requested Pond Water Surface Elevations	
Minimum (Headwater)	676.90 ft
Increment (Headwater)	0.10 ft
Maximum (Headwater)	682.00 ft

Outlet Connectivity

Structure Type	Outlet ID	Direction	Outfall	E1 (ft)	E2 (ft)
Orifice-Circular	Orifice - 1	Forward + Reverse	TW	676.93	682.00
Rectangular Weir	Weir - 1	Forward + Reverse	TW	681.00	682.00
Tailwater Settings	Tailwater			(N/A)	(N/A)

Subsection: Outlet Input Data
Label: APN5

Return Event: 100 years
Storm Event: 100YR-24HR

Structure ID: Orifice - 1	
Structure Type: Orifice-Circular	
<hr/>	
Number of Openings	1
Elevation	676.93 ft
Orifice Diameter	12.0 in
Orifice Coefficient	0.600
<hr/>	
Structure ID: Weir - 1	
Structure Type: Rectangular Weir	
<hr/>	
Number of Openings	1
Elevation	681.00 ft
Weir Length	75.00 ft
Weir Coefficient	3.00 (ft ^{0.5})/s
<hr/>	

Subsection: Outlet Input Data
 Label: APN6

Return Event: 100 years
 Storm Event: 100YR-24HR

Requested Pond Water Surface Elevations	
Minimum (Headwater)	667.50 ft
Increment (Headwater)	0.10 ft
Maximum (Headwater)	674.00 ft

Outlet Connectivity

Structure Type	Outlet ID	Direction	Outfall	E1 (ft)	E2 (ft)
Culvert-Circular	Culvert - 1	Forward + Reverse	TW	667.52	674.00
Rectangular Weir	Weir - 1	Forward + Reverse	TW	673.00	674.00
Tailwater Settings	Tailwater			(N/A)	(N/A)

Subsection: Outlet Input Data
 Label: APN6

Return Event: 100 years
 Storm Event: 100YR-24HR

Structure ID: Culvert - 1	
Structure Type: Culvert-Circular	
Number of Barrels	1
Diameter	18.0 in
Length	57.00 ft
Length (Computed Barrel)	57.01 ft
Slope (Computed)	0.019 ft/ft
Outlet Control Data	
Manning's n	0.013
Ke	0.200
Kb	0.018
Kr	0.000
Convergence Tolerance	0.00 ft
Inlet Control Data	
Equation Form	Form 1
K	0.0045
M	2.0000
C	0.0317
Y	0.6900
T1 ratio (HW/D)	1.086
T2 ratio (HW/D)	1.188
Slope Correction Factor	-0.500

Use unsubmerged inlet control 0 equation below T1 elevation.

Use submerged inlet control 0 equation above T2 elevation

In transition zone between unsubmerged and submerged inlet control, interpolate between flows at T1 & T2...

T1 Elevation	669.15 ft	T1 Flow	7.58 ft ³ /s
T2 Elevation	669.30 ft	T2 Flow	8.66 ft ³ /s

Subsection: Outlet Input Data
Label: APN6

Return Event: 100 years
Storm Event: 100YR-24HR

Structure ID: Weir - 1	
Structure Type: Rectangular Weir	
<hr/>	
Number of Openings	1
Elevation	673.00 ft
Weir Length	110.00 ft
Weir Coefficient	3.00 (ft ^{0.5})/s

Subsection: Outlet Input Data
 Label: Rev North Pond Outlet

Return Event: 100 years
 Storm Event: 100YR-24HR

Requested Pond Water Surface Elevations	
Minimum (Headwater)	649.00 ft
Increment (Headwater)	0.10 ft
Maximum (Headwater)	655.00 ft

Outlet Connectivity

Structure Type	Outlet ID	Direction	Outfall	E1 (ft)	E2 (ft)
Orifice-Circular	100 - Yr Restrictor	Forward + Reverse	TW	651.20	655.00
Orifice-Circular	2 - Year Restrictor	Forward + Reverse	TW	649.00	651.20
Vnotch Weir	Weir - 1	Forward + Reverse	TW	654.00	655.00
Tailwater Settings	Tailwater			(N/A)	(N/A)

Subsection: Outlet Input Data
Label: Rev North Pond Outlet

Return Event: 100 years
Storm Event: 100YR-24HR

Structure ID: 2 - Year Restrictor	
Structure Type: Orifice-Circular	
Number of Openings	1
Elevation	649.00 ft
Orifice Diameter	3.0 in
Orifice Coefficient	0.600

Structure ID: Weir - 1	
Structure Type: Vnotch Weir	
Number of Openings	1
Elevation	654.00 ft
V-Notch Angle	45.00 degrees
Weir Coefficient	3.00 (ft ^{0.5})/s

Structure ID: 100 - Yr Restrictor	
Structure Type: Orifice-Circular	
Number of Openings	1
Elevation	649.00 ft
Orifice Diameter	5.5 in
Orifice Coefficient	0.600

Subsection: Outlet Input Data
 Label: South Pond Outlet

Return Event: 100 years
 Storm Event: 100YR-24HR

Requested Pond Water Surface Elevations	
Minimum (Headwater)	650.00 ft
Increment (Headwater)	0.10 ft
Maximum (Headwater)	655.00 ft

Outlet Connectivity

Structure Type	Outlet ID	Direction	Outfall	E1 (ft)	E2 (ft)
Orifice-Circular	100 - Yr Restrictor	Forward + Reverse	TW	651.90	655.00
Orifice-Circular	2 - Year Restrictor	Forward + Reverse	TW	650.00	651.90
Vnotch Weir	Weir - 1	Forward + Reverse	TW	654.50	655.00
Tailwater Settings	Tailwater			(N/A)	(N/A)

Subsection: Outlet Input Data
Label: South Pond Outlet

Return Event: 100 years
Storm Event: 100YR-24HR

Structure ID: 2 - Year Restrictor	
Structure Type: Orifice-Circular	
Number of Openings	1
Elevation	650.00 ft
Orifice Diameter	3.0 in
Orifice Coefficient	0.600

Structure ID: Weir - 1	
Structure Type: Vnotch Weir	
Number of Openings	1
Elevation	654.50 ft
V-Notch Angle	45.00 degrees
Weir Coefficient	3.00 (ft ^{0.5})/s

Structure ID: 100 - Yr Restrictor	
Structure Type: Orifice-Circular	
Number of Openings	1
Elevation	650.00 ft
Orifice Diameter	5.0 in
Orifice Coefficient	0.600

Subsection: Outlet Input Data
 Label: TAM1

Return Event: 100 years
 Storm Event: 100YR-24HR

Requested Pond Water Surface Elevations	
Minimum (Headwater)	657.00 ft
Increment (Headwater)	0.10 ft
Maximum (Headwater)	668.00 ft

Outlet Connectivity

Structure Type	Outlet ID	Direction	Outfall	E1 (ft)	E2 (ft)
Culvert-Circular	Culvert - East	Forward + Reverse	TW	659.00	668.00
Culvert-Circular	Culvert - West	Forward + Reverse	TW	659.00	668.00
Rectangular Weir	Weir - 1	Forward + Reverse	TW	667.00	668.00
Tailwater Settings	Tailwater			(N/A)	(N/A)

Subsection: Outlet Input Data
 Label: TAM1

Return Event: 100 years
 Storm Event: 100YR-24HR

Structure ID: Culvert - West	
Structure Type: Culvert-Circular	
Number of Barrels	1
Diameter	66.0 in
Length	98.00 ft
Length (Computed Barrel)	98.00 ft
Slope (Computed)	0.006 ft/ft
Outlet Control Data	
Manning's n	0.013
Ke	0.200
Kb	0.003
Kr	0.000
Convergence Tolerance	0.00 ft
Inlet Control Data	
Equation Form	Form 1
K	0.0045
M	2.0000
C	0.0317
Y	0.6900
T1 ratio (HW/D)	1.092
T2 ratio (HW/D)	1.194
Slope Correction Factor	-0.500

Use unsubmerged inlet control 0 equation below T1 elevation.

Use submerged inlet control 0 equation above T2 elevation

In transition zone between unsubmerged and submerged inlet control, interpolate between flows at T1 & T2...

T1 Elevation	665.01 ft	T1 Flow	195.01 ft ³ /s
T2 Elevation	665.57 ft	T2 Flow	222.87 ft ³ /s

Subsection: Outlet Input Data
 Label: TAM1

Return Event: 100 years
 Storm Event: 100YR-24HR

Structure ID: Weir - 1	
Structure Type: Rectangular Weir	
Number of Openings	1
Elevation	667.00 ft
Weir Length	200.00 ft
Weir Coefficient	3.00 (ft ^{0.5})/s

Structure ID: Culvert - East	
Structure Type: Culvert-Circular	
Number of Barrels	1
Diameter	66.0 in
Length	97.00 ft
Length (Computed Barrel)	97.00 ft
Slope (Computed)	0.004 ft/ft

Outlet Control Data	
Manning's n	0.013
Ke	0.200
Kb	0.003
Kr	0.000
Convergence Tolerance	0.00 ft

Inlet Control Data	
Equation Form	Form 1
K	0.0045
M	2.0000
C	0.0317
Y	0.6900
T1 ratio (HW/D)	1.093
T2 ratio (HW/D)	1.195
Slope Correction Factor	-0.500

Use unsubmerged inlet control 0 equation below T1 elevation.
 Use submerged inlet control 0 equation above T2 elevation

In transition zone between unsubmerged and submerged inlet control, interpolate between flows at T1 & T2...

T1 Elevation	665.01 ft	T1 Flow	195.01 ft ³ /s
T2 Elevation	665.57 ft	T2 Flow	222.87 ft ³ /s

Subsection: Outlet Input Data
Label: TAM2

Return Event: 100 years
Storm Event: 100YR-24HR

Requested Pond Water Surface Elevations	
Minimum (Headwater)	662.40 ft
Increment (Headwater)	0.10 ft
Maximum (Headwater)	668.00 ft

Outlet Connectivity

Structure Type	Outlet ID	Direction	Outfall	E1 (ft)	E2 (ft)
Culvert-Circular	Culvert - 1	Forward + Reverse	TW	662.40	668.00
Rectangular Weir	Weir - 1	Forward + Reverse	TW	667.00	668.00
Tailwater Settings	Tailwater			(N/A)	(N/A)

Subsection: Outlet Input Data
 Label: TAM2

Return Event: 100 years
 Storm Event: 100YR-24HR

Structure ID: Culvert - 1	
Structure Type: Culvert-Circular	
Number of Barrels	1
Diameter	36.0 in
Length	240.00 ft
Length (Computed Barrel)	240.00 ft
Slope (Computed)	0.004 ft/ft
Outlet Control Data	
Manning's n	0.013
Ke	0.200
Kb	0.007
Kr	0.000
Convergence Tolerance	0.00 ft
Inlet Control Data	
Equation Form	Form 1
K	0.0045
M	2.0000
C	0.0317
Y	0.6900
T1 ratio (HW/D)	1.093
T2 ratio (HW/D)	1.195
Slope Correction Factor	-0.500

Use unsubmerged inlet control 0 equation below T1 elevation.

Use submerged inlet control 0 equation above T2 elevation

In transition zone between unsubmerged and submerged inlet control, interpolate between flows at T1 & T2...

T1 Elevation	665.68 ft	T1 Flow	42.85 ft ³ /s
T2 Elevation	665.99 ft	T2 Flow	48.97 ft ³ /s

Subsection: Outlet Input Data
Label: TAM2

Return Event: 100 years
Storm Event: 100YR-24HR

Structure ID: Weir - 1	
Structure Type: Rectangular Weir	
<hr/>	
Number of Openings	1
Elevation	667.00 ft
Weir Length	26.00 ft
Weir Coefficient	3.00 (ft ^{0.5})/s

Subsection: Outlet Input Data
 Label: TAM3

Return Event: 100 years
 Storm Event: 100YR-24HR

Requested Pond Water Surface Elevations	
Minimum (Headwater)	661.50 ft
Increment (Headwater)	0.10 ft
Maximum (Headwater)	668.00 ft

Outlet Connectivity

Structure Type	Outlet ID	Direction	Outfall	E1 (ft)	E2 (ft)
Culvert-Circular	Culvert - 1	Forward + Reverse	TW	661.50	668.00
Rectangular Weir	Weir - 1	Forward + Reverse	TW	667.00	668.00
Tailwater Settings	Tailwater			(N/A)	(N/A)

Subsection: Outlet Input Data
 Label: TAM3

Return Event: 100 years
 Storm Event: 100YR-24HR

Structure ID: Culvert - 1	
Structure Type: Culvert-Circular	
Number of Barrels	1
Diameter	36.0 in
Length	169.00 ft
Length (Computed Barrel)	169.01 ft
Slope (Computed)	0.009 ft/ft
Outlet Control Data	
Manning's n	0.013
Ke	0.200
Kb	0.007
Kr	0.000
Convergence Tolerance	0.00 ft
Inlet Control Data	
Equation Form	Form 1
K	0.0045
M	2.0000
C	0.0317
Y	0.6900
T1 ratio (HW/D)	1.091
T2 ratio (HW/D)	1.193
Slope Correction Factor	-0.500

Use unsubmerged inlet control 0 equation below T1 elevation.

Use submerged inlet control 0 equation above T2 elevation

In transition zone between unsubmerged and submerged inlet control, interpolate between flows at T1 & T2...

T1 Elevation	664.77 ft	T1 Flow	42.85 ft ³ /s
T2 Elevation	665.08 ft	T2 Flow	48.97 ft ³ /s

Subsection: Outlet Input Data
Label: TAM3

Return Event: 100 years
Storm Event: 100YR-24HR

Structure ID: Weir - 1	
Structure Type: Rectangular Weir	
<hr/>	
Number of Openings	1
Elevation	667.00 ft
Weir Length	188.00 ft
Weir Coefficient	3.00 (ft ^{0.5})/s

Subsection: Outlet Input Data
 Label: TAM4

Return Event: 100 years
 Storm Event: 100YR-24HR

Requested Pond Water Surface Elevations	
Minimum (Headwater)	660.00 ft
Increment (Headwater)	0.10 ft
Maximum (Headwater)	666.00 ft

Outlet Connectivity

Structure Type	Outlet ID	Direction	Outfall	E1 (ft)	E2 (ft)
Culvert-Circular	24in	Forward + Reverse	TW	660.00	666.00
Culvert-Circular	Dual 18in	Forward + Reverse	TW	664.00	666.00
Rectangular Weir	Weir - 1	Forward + Reverse	TW	665.00	666.00
Tailwater Settings	Tailwater			(N/A)	(N/A)

Subsection: Outlet Input Data
 Label: TAM4

Return Event: 100 years
 Storm Event: 100YR-24HR

Structure ID: 24in	
Structure Type: Culvert-Circular	
Number of Barrels	1
Diameter	24.0 in
Length	30.00 ft
Length (Computed Barrel)	30.02 ft
Slope (Computed)	0.033 ft/ft
Outlet Control Data	
Manning's n	0.013
Ke	0.200
Kb	0.012
Kr	0.000
Convergence Tolerance	0.00 ft
Inlet Control Data	
Equation Form	Form 1
K	0.0045
M	2.0000
C	0.0317
Y	0.6900
T1 ratio (HW/D)	1.079
T2 ratio (HW/D)	1.181
Slope Correction Factor	-0.500

Use unsubmerged inlet control 0 equation below T1 elevation.

Use submerged inlet control 0 equation above T2 elevation

In transition zone between unsubmerged and submerged inlet control, interpolate between flows at T1 & T2...

T1 Elevation	662.16 ft	T1 Flow	15.55 ft ³ /s
T2 Elevation	662.36 ft	T2 Flow	17.77 ft ³ /s

Subsection: Outlet Input Data
 Label: TAM4

Return Event: 100 years
 Storm Event: 100YR-24HR

Structure ID: Dual 18in	
Structure Type: Culvert-Circular	
Number of Barrels	2
Diameter	18.0 in
Length	14.00 ft
Length (Computed Barrel)	14.04 ft
Slope (Computed)	0.071 ft/ft
Outlet Control Data	
Manning's n	0.013
Ke	0.200
Kb	0.018
Kr	0.000
Convergence Tolerance	0.00 ft
Inlet Control Data	
Equation Form	Form 1
K	0.0045
M	2.0000
C	0.0317
Y	0.6900
T1 ratio (HW/D)	1.060
T2 ratio (HW/D)	1.161
Slope Correction Factor	-0.500

Use unsubmerged inlet control 0 equation below T1 elevation.

Use submerged inlet control 0 equation above T2 elevation

In transition zone between unsubmerged and submerged inlet control, interpolate between flows at T1 & T2...

T1 Elevation	665.59 ft	T1 Flow	7.58 ft ³ /s
T2 Elevation	665.74 ft	T2 Flow	8.66 ft ³ /s

Subsection: Outlet Input Data
Label: TAM4

Return Event: 100 years
Storm Event: 100YR-24HR

Structure ID: Weir - 1	
Structure Type: Rectangular Weir	
<hr/>	
Number of Openings	1
Elevation	665.00 ft
Weir Length	200.00 ft
Weir Coefficient	3.00 (ft ^{0.5})/s

Subsection: Outlet Input Data
 Label: TAM5

Return Event: 100 years
 Storm Event: 100YR-24HR

Requested Pond Water Surface Elevations	
Minimum (Headwater)	658.00 ft
Increment (Headwater)	0.10 ft
Maximum (Headwater)	662.00 ft

Outlet Connectivity

Structure Type	Outlet ID	Direction	Outfall	E1 (ft)	E2 (ft)
Culvert-Circular	Culvert - 1	Forward + Reverse	TW	657.10	662.00
Rectangular Weir	Weir - 1	Forward + Reverse	TW	661.00	662.00
Tailwater Settings	Tailwater			(N/A)	(N/A)

Subsection: Outlet Input Data
 Label: TAM5

Return Event: 100 years
 Storm Event: 100YR-24HR

Structure ID: Culvert - 1	
Structure Type: Culvert-Circular	
Number of Barrels	1
Diameter	30.0 in
Length	52.40 ft
Length (Computed Barrel)	52.40 ft
Slope (Computed)	0.000 ft/ft
Outlet Control Data	
Manning's n	0.013
Ke	0.200
Kb	0.009
Kr	0.000
Convergence Tolerance	0.00 ft
Inlet Control Data	
Equation Form	Form 1
K	0.0045
M	2.0000
C	0.0317
Y	0.6900
T1 ratio (HW/D)	1.095
T2 ratio (HW/D)	1.197
Slope Correction Factor	-0.500

Use unsubmerged inlet control 0 equation below T1 elevation.
 Use submerged inlet control 0 equation above T2 elevation

In transition zone between unsubmerged and submerged inlet control, interpolate between flows at T1 & T2...

T1 Elevation	659.84 ft	T1 Flow	27.16 ft ³ /s
T2 Elevation	660.09 ft	T2 Flow	31.05 ft ³ /s

Subsection: Outlet Input Data
Label: TAM5

Return Event: 100 years
Storm Event: 100YR-24HR

Structure ID: Weir - 1	
Structure Type: Rectangular Weir	
<hr/>	
Number of Openings	1
Elevation	661.00 ft
Weir Length	90.00 ft
Weir Coefficient	3.00 (ft ^{0.5})/s

Subsection: Outlet Input Data
 Label: TAM6

Return Event: 100 years
 Storm Event: 100YR-24HR

Requested Pond Water Surface Elevations	
Minimum (Headwater)	654.00 ft
Increment (Headwater)	0.10 ft
Maximum (Headwater)	662.00 ft

Outlet Connectivity

Structure Type	Outlet ID	Direction	Outfall	E1 (ft)	E2 (ft)
Culvert-Box	Culvert - 1	Forward + Reverse	TW	653.73	662.00
Rectangular Weir	Weir - 1	Forward + Reverse	TW	661.00	662.00
Tailwater Settings	Tailwater			(N/A)	(N/A)

Subsection: Outlet Input Data
 Label: TAM6

Return Event: 100 years
 Storm Event: 100YR-24HR

Structure ID: Culvert - 1	
Structure Type: Culvert-Box	
Number of Barrels	1
Width	12.00 ft
Height	6.00 ft
Length	22.00 ft
Length (Computed Barrel)	22.01 ft
Slope (Computed)	0.025 ft/ft
Outlet Control Data	
Manning's n	0.013
Ke	0.500
Kb	0.002
Kr	0.000
Convergence Tolerance	0.00 ft
Inlet Control Data	
Equation Form	Form 2
K	0.5100
M	0.6670
C	0.0309
Y	0.8000
T1 ratio (HW/D)	1.176
T2 ratio (HW/D)	1.282
Slope Correction Factor	-0.500

Use unsubmerged inlet control 1 equation below T1 elevation.

Use submerged inlet control 1 equation above T2 elevation

In transition zone between unsubmerged and submerged inlet control, interpolate between flows at T1 & T2...

T1 Elevation	660.79 ft	T1 Flow	617.27 ft ³ /s
T2 Elevation	661.42 ft	T2 Flow	705.45 ft ³ /s

Subsection: Outlet Input Data
Label: TAM6

Return Event: 100 years
Storm Event: 100YR-24HR

Structure ID: Weir - 1	
Structure Type: Rectangular Weir	
<hr/>	
Number of Openings	1
Elevation	661.00 ft
Weir Length	170.00 ft
Weir Coefficient	3.00 (ft ^{0.5})/s

Subsection: Outlet Input Data
 Label: TAM7

Return Event: 100 years
 Storm Event: 100YR-24HR

Requested Pond Water Surface Elevations	
Minimum (Headwater)	650.00 ft
Increment (Headwater)	0.10 ft
Maximum (Headwater)	658.00 ft

Outlet Connectivity

Structure Type	Outlet ID	Direction	Outfall	E1 (ft)	E2 (ft)
User Defined Table	User Defined Rating Table - 1	Forward + Reverse	TW	0.00	658.00
Tailwater Settings	Tailwater			(N/A)	(N/A)

Subsection: Outlet Input Data
 Label: TAM7

Return Event: 100 years
 Storm Event: 100YR-24HR

Structure ID: User Defined Rating Table - 1
 Structure Type: User Defined Table

Elevation (ft)	Flow (ft ³ /s)
650.00	0.00
650.20	0.00
650.50	0.00
650.80	0.00
651.10	0.00
651.45	10.00
651.68	20.00
651.86	30.00
652.02	40.00
652.17	50.00
652.31	60.00
652.44	70.00
652.56	80.00
652.68	90.00
652.80	100.00
653.07	125.00
653.33	150.00
653.57	175.00
653.81	200.00
654.03	225.00
654.25	250.00
654.46	275.00
654.66	300.00
654.86	325.00
655.05	350.00
655.24	375.00
655.43	400.00
655.61	425.00
655.80	450.00
655.99	475.00
656.18	500.00
656.37	525.00
656.55	550.00
656.73	575.00
656.91	600.00
657.41	625.00
657.63	650.00
657.86	675.00
658.00	691.00

Subsection: Outlet Input Data
 Label: West Tributary Offsite Flow

Return Event: 100 years
 Storm Event: 100YR-24HR

Requested Pond Water Surface Elevations	
Minimum (Headwater)	647.00 ft
Increment (Headwater)	0.10 ft
Maximum (Headwater)	655.00 ft

Outlet Connectivity

Structure Type	Outlet ID	Direction	Outfall	E1 (ft)	E2 (ft)
User Defined Table	User Defined Rating Table - 1	Forward	TW	0.00	655.00
Tailwater Settings	Tailwater			(N/A)	(N/A)

Subsection: Outlet Input Data
 Label: West Tributary Offsite Flow

Return Event: 100 years
 Storm Event: 100YR-24HR

Structure ID: User Defined Rating Table - 1
 Structure Type: User Defined Table

Elevation (ft)	Flow (ft ³ /s)
647.00	0.00
647.25	10.00
647.54	20.00
647.74	30.00
647.90	40.00
648.03	50.00
648.14	60.00
648.24	70.00
648.35	80.00
648.43	90.00
648.52	100.00
648.75	125.00
648.94	150.00
649.11	175.00
649.29	200.00
649.44	225.00
649.60	250.00
649.75	275.00
649.89	300.00
650.02	325.00
650.15	350.00
650.28	375.00
650.40	400.00
650.52	425.00
650.64	450.00
650.74	475.00
650.83	500.00
650.97	525.00
651.30	550.00
651.80	575.00
651.82	600.00
651.97	625.00
652.14	650.00
652.32	675.00
652.49	700.00
652.66	725.00
652.83	750.00
653.00	775.00
653.18	800.00
653.35	825.00
653.52	850.00
653.69	875.00
653.87	900.00
654.04	925.00

Subsection: Outlet Input Data
 Label: West Tributary Offsite Flow

Return Event: 100 years
 Storm Event: 100YR-24HR

Elevation (ft)	Flow (ft ³ /s)
654.21	950.00
654.38	975.00
654.55	1,000.00
654.73	1,025.00
654.90	1,050.00
655.00	1,064.00

Structure ID: TW
 Structure Type: TW Setup, DS Channel

Tailwater Type	Free Outfall
----------------	--------------

Convergence Tolerances

Maximum Iterations	30
Tailwater Tolerance (Minimum)	0.01 ft
Tailwater Tolerance (Maximum)	0.50 ft
Headwater Tolerance (Minimum)	0.01 ft
Headwater Tolerance (Maximum)	0.50 ft
Flow Tolerance (Minimum)	0.001 ft ³ /s
Flow Tolerance (Maximum)	10.000 ft ³ /s

Index

1

101 (Unit Hydrograph Summary, 100 years)...4, 5

102 (Unit Hydrograph Summary, 100 years)...6, 7

2

201 (Unit Hydrograph Summary, 100 years)...8, 9

202 (Unit Hydrograph Summary, 100 years)...10, 11

203 (Unit Hydrograph Summary, 100 years)...12, 13

204 (Unit Hydrograph Summary, 100 years)...14, 15

205 (Unit Hydrograph Summary, 100 years)...16, 17

206 (Unit Hydrograph Summary, 100 years)...18, 19

3

301 (Unit Hydrograph Summary, 100 years)...20, 21

302 (Unit Hydrograph Summary, 100 years)...22, 23

303 (Unit Hydrograph Summary, 100 years)...24, 25

A

APN2 (Unit Hydrograph Summary, 100 years)...26, 27

APN3 (Elevation vs. Volume Curve, 100 years)...70

APN3 (Unit Hydrograph Summary, 100 years)...28, 29

APN3 Outlet (Outlet Input Data, 100 years)...84, 85, 86, 87

APN4 (Elevation vs. Volume Curve, 100 years)...71

APN4 (Unit Hydrograph Summary, 100 years)...30, 31

APN4 Outlet (Outlet Input Data, 100 years)...88, 89, 90

APN5 (Elevation vs. Volume Curve, 100 years)...72

APN5 (Outlet Input Data, 100 years)...91, 92

APN5 (Unit Hydrograph Summary, 100 years)...32, 33

APN6 (Elevation vs. Volume Curve, 100 years)...73

APN6 (Outlet Input Data, 100 years)...93, 94, 95

APN6 (Unit Hydrograph Summary, 100 years)...34, 35

ASH4 (Unit Hydrograph Summary, 100 years)...36, 37

C

CREEK OUTFALL 1 (Read Hydrograph, 100 years)...38, 39, 40, 41, 42, 43

CREEK OUTFALL 2 (Read Hydrograph, 100 years)...44, 45, 46, 47, 48, 49

M

Master Network Summary...1, 2

N

North Pond (Elevation vs. Volume Curve, 100 years)...74

P

PR1 (Unit Hydrograph Summary, 100 years)...50, 51

PR2 (Unit Hydrograph Summary, 100 years)...52, 53

PR3 (Unit Hydrograph Summary, 100 years)...54, 55

R

Rev North Pond Outlet (Outlet Input Data, 100 years)...96, 97

S

South Pond (Elevation vs. Volume Curve, 100 years)...75

South Pond Outlet (Outlet Input Data, 100 years)...98, 99

T

TAM1 (Elevation vs. Volume Curve, 100 years)...76

TAM1 (Outlet Input Data, 100 years)...100, 101, 102

TAM1 (Unit Hydrograph Summary, 100 years)...56, 57

TAM2 (Elevation vs. Volume Curve, 100 years)...77

TAM2 (Outlet Input Data, 100 years)...103, 104, 105

TAM2 (Unit Hydrograph Summary, 100 years)...58, 59

TAM3 (Elevation vs. Volume Curve, 100 years)...78

TAM3 (Outlet Input Data, 100 years)...106, 107, 108

TAM3 (Unit Hydrograph Summary, 100 years)...60, 61

TAM4 (Elevation vs. Volume Curve, 100 years)...79

TAM4 (Outlet Input Data, 100 years)...109, 110, 111, 112

TAM4 (Unit Hydrograph Summary, 100 years)...62, 63

TAM5 (Elevation vs. Volume Curve, 100 years)...80

TAM5 (Outlet Input Data, 100 years)...113, 114, 115

TAM5 (Unit Hydrograph Summary, 100 years)...64, 65

TAM6 (Elevation vs. Volume Curve, 100 years)...81

TAM6 (Outlet Input Data, 100 years)...116, 117, 118

TAM6 (Unit Hydrograph Summary, 100 years)...66, 67

TAM7 (Elevation vs. Volume Curve, 100 years)...82

TAM7 (Outlet Input Data, 100 years)...119, 120

TAM7 (Unit Hydrograph Summary, 100 years)...68, 69

U

UPDATED 100YR 12HR-48HR (Time-Depth Curve, 100 years)...3

W

West Tributary - Clow Creek (Elevation vs. Volume Curve, 100 years)...83

West Tributary Offsite Flow (Outlet Input Data, 100 years)...121, 122, 123

Scenario Calculation Summary

Scenario Summary	
ID	7999
Label	2 Yr - 24 Hr
Notes	
Active Topology	Base Active Topology
Hydrology	Base Hydrology
Rainfall Runoff	2 Yr - 24 Hr
Physical	Base Physical
Initial Condition	Base Initial Condition
Boundary Condition	Base Boundary Condition
Infiltration and Inflow	Base Infiltration and Inflow
Output	Base Output
User Data Extensions	Base User Data Extensions
PondPack Engine Calculation Options	12Hr

Output Summary			
Output Increment	0.100 hours	Duration	24.000 hours

Rainfall Summary			
Return Event Tag	12 Hr	Rainfall Type	Time-Depth Curve
Total Depth	3.3 in	Storm Event	2YR-24HR

ICPM Output Summary			
Target Convergence	0.00 ft ³ /s	ICPM Time Step	0.100 hours
Maximum Iterations	35		

Executive Summary (Nodes)

Label	Scenario	Return Event (years)	Truncation	Hydrograph Volume (ac-ft)	Time to Peak (hours)	Peak Flow (ft ³ /s)	Maximum Water Surface Elevation (ft)	Maximum Pond Storage (ac-ft)
101	2 Yr - 24 Hr	2	None	2.424	16.000	3.31	(N/A)	(N/A)
102	2 Yr - 24 Hr	2	None	0.521	16.000	0.77	(N/A)	(N/A)
201	2 Yr - 24 Hr	2	None	0.031	17.000	0.06	(N/A)	(N/A)
202	2 Yr - 24 Hr	2	None	0.058	17.000	0.11	(N/A)	(N/A)
203	2 Yr - 24 Hr	2	None	0.119	17.000	0.20	(N/A)	(N/A)
204	2 Yr - 24 Hr	2	None	0.015	17.000	0.03	(N/A)	(N/A)
205	2 Yr - 24 Hr	2	None	0.027	17.000	0.05	(N/A)	(N/A)
206	2 Yr - 24 Hr	2	None	0.028	17.000	0.05	(N/A)	(N/A)
301	2 Yr - 24 Hr	2	None	0.009	17.000	0.02	(N/A)	(N/A)
302	2 Yr - 24 Hr	2	None	0.039	17.000	0.08	(N/A)	(N/A)
303	2 Yr - 24 Hr	2	None	0.115	17.000	0.22	(N/A)	(N/A)
APN2	2 Yr - 24 Hr	2	None	0.932	17.000	1.60	(N/A)	(N/A)
APN3	2 Yr - 24 Hr	2	None	7.541	16.100	11.17	(N/A)	(N/A)
APN3 (IN)	2 Yr - 24 Hr	2	None	7.541	16.100	11.17	(N/A)	(N/A)
APN3 (OUT)	2 Yr - 24 Hr	2	None	4.751	18.600	7.09	681.38	3.746
APN4 (IN)	2 Yr - 24 Hr	2	None	2.303	16.200	3.54	(N/A)	(N/A)
APN4 (OUT)	2 Yr - 24 Hr	2	None	1.903	17.300	2.84	681.39	0.724
APN4	2 Yr - 24 Hr	2	None	2.303	16.200	3.54	(N/A)	(N/A)
APN5 (IN)	2 Yr - 24 Hr	2	None	7.201	17.100	10.94	(N/A)	(N/A)
APN5 (OUT)	2 Yr - 24 Hr	2	None	3.758	20.600	5.01	679.19	3.801
APN5	2 Yr - 24 Hr	2	None	5.298	16.200	8.16	(N/A)	(N/A)
APN6 (IN)	2 Yr - 24 Hr	2	None	10.046	17.100	14.81	(N/A)	(N/A)
APN6 (OUT)	2 Yr - 24 Hr	2	None	2.688	24.000	5.47	668.88	7.313

Scenario Calculation Summary

Executive Summary (Nodes)

Label	Scenario	Return Event (years)	Truncation	Hydrograph Volume (ac-ft)	Time to Peak (hours)	Peak Flow (ft ³ /s)	Maximum Water Surface Elevation (ft)	Maximum Pond Storage (ac-ft)
APN6	2 Yr - 24 Hr	2	None	6.288	17.100	10.58	(N/A)	(N/A)
ASH4	2 Yr - 24 Hr	2	None	0.605	16.000	0.93	(N/A)	(N/A)
CLOW CREEK OUTFALL OFF -SITE	2 Yr - 24 Hr	2	None	268.986	10.200	203.51	(N/A)	(N/A)
CREEK OUTFALL 1	2 Yr - 24 Hr	2	None	96.028	12.200	82.38	(N/A)	(N/A)
CREEK OUTFALL 2	2 Yr - 24 Hr	2	None	152.418	0.100	168.35	(N/A)	(N/A)
J-5	2 Yr - 24 Hr	2	None	254.924	7.800	219.77	(N/A)	(N/A)
J-6	2 Yr - 24 Hr	2	None	5.559	16.000	8.47	(N/A)	(N/A)
North Pond (IN)	2 Yr - 24 Hr	2	None	0.560	16.000	0.84	(N/A)	(N/A)
North Pond (OUT)	2 Yr - 24 Hr	2	None	0.283	20.500	0.32	651.00	0.318
North Pond (Reverse)	2 Yr - 24 Hr	2	None	-0.003	9.400	-0.04	(N/A)	(N/A)
Offsite Runoff (East)	2 Yr - 24 Hr	2	None	0.015	17.000	0.03	(N/A)	(N/A)
Offsite Runoff (South)	2 Yr - 24 Hr	2	None	0.119	17.000	0.20	(N/A)	(N/A)
PR1	2 Yr - 24 Hr	2	None	2.769	16.000	4.21	(N/A)	(N/A)
PR2	2 Yr - 24 Hr	2	None	1.365	16.000	2.08	(N/A)	(N/A)
PR3	2 Yr - 24 Hr	2	None	0.820	16.000	1.25	(N/A)	(N/A)
South Pond (IN)	2 Yr - 24 Hr	2	None	2.424	16.000	3.31	(N/A)	(N/A)
South Pond (OUT)	2 Yr - 24 Hr	2	None	0.282	24.000	0.30	651.75	2.140
TAM1 (IN)	2 Yr - 24 Hr	2	None	276.694	7.900	221.01	(N/A)	(N/A)
TAM1 (OUT)	2 Yr - 24 Hr	2	None	264.475	9.000	205.30	663.13	17.589
TAM1	2 Yr - 24 Hr	2	None	17.819	16.100	27.70	(N/A)	(N/A)
TAM2 (IN)	2 Yr - 24 Hr	2	None	3.696	24.000	5.75	(N/A)	(N/A)
TAM2 (OUT)	2 Yr - 24 Hr	2	None	2.885	24.000	5.58	663.45	0.788
TAM2	2 Yr - 24 Hr	2	None	1.008	16.000	1.51	(N/A)	(N/A)
TAM3 (IN)	2 Yr - 24 Hr	2	None	4.344	24.000	5.98	(N/A)	(N/A)
TAM3 (OUT)	2 Yr - 24 Hr	2	None	3.213	24.000	5.68	662.56	1.085
TAM3	2 Yr - 24 Hr	2	None	1.460	16.000	2.20	(N/A)	(N/A)
TAM4 (IN)	2 Yr - 24 Hr	2	None	11.682	17.100	15.62	(N/A)	(N/A)
TAM4 (OUT)	2 Yr - 24 Hr	2	None	5.971	20.600	9.27	661.61	5.844
TAM4	2 Yr - 24 Hr	2	None	8.469	16.200	12.79	(N/A)	(N/A)
TAM5 (IN)	2 Yr - 24 Hr	2	None	7.444	20.100	10.07	(N/A)	(N/A)
TAM5 (OUT)	2 Yr - 24 Hr	2	None	4.887	23.100	9.26	658.65	2.487
TAM5	2 Yr - 24 Hr	2	None	1.474	16.100	2.12	(N/A)	(N/A)
TAM6 (IN)	2 Yr - 24 Hr	2	None	266.859	9.000	205.34	(N/A)	(N/A)
TAM6 (OUT)	2 Yr - 24 Hr	2	None	264.413	9.500	203.85	657.37	3.529
TAM6	2 Yr - 24 Hr	2	None	2.384	17.000	4.07	(N/A)	(N/A)
TAM7 (IN)	2 Yr - 24 Hr	2	None	278.364	9.500	205.27	(N/A)	(N/A)
TAM7 (OUT)	2 Yr - 24 Hr	2	None	268.735	10.100	203.44	653.84	10.654
TAM7	2 Yr - 24 Hr	2	None	9.064	17.100	14.18	(N/A)	(N/A)
West Tributary - Clow Creek (IN)	2 Yr - 24 Hr	2	None	269.564	10.100	203.53	(N/A)	(N/A)

Scenario Calculation Summary

Executive Summary (Nodes)

Label	Scenario	Return Event (years)	Truncation	Hydrograph Volume (ac-ft)	Time to Peak (hours)	Peak Flow (ft ³ /s)	Maximum Water Surface Elevation (ft)	Maximum Pond Storage (ac-ft)
West Tributary - Clow Creek (OUT)	2 Yr - 24 Hr	2	None	268.986	10.200	203.51	649.31	0.077

Executive Summary (Links)

Label	Type	Location	Hydrograph Volume (ac-ft)	Peak Time (hours)	Peak Flow (ft ³ /s)	End Point	Node Flow Direction
APN3 Outlet	Pond Outlet	Upstream	7.541	16.100	11.17	APN3	Pond Inflow
APN3 Outlet	Pond Outlet	Outflow	4.751	18.600	7.09	APN3	Pond Outflow
APN3 Outlet	Pond Outlet	Link	4.716	18.600	7.09		
APN3 Outlet	Pond Outlet	Downstream	276.694	7.900	221.01	TAM1	
APN4 Outlet	Pond Outlet	Upstream	2.303	16.200	3.54	APN4	Pond Inflow
APN4 Outlet	Pond Outlet	Outflow	1.903	17.300	2.84	APN4	Pond Outflow
APN4 Outlet	Pond Outlet	Link	1.903	17.300	2.84		
APN4 Outlet	Pond Outlet	Downstream	7.201	17.100	10.94	APN5	
APN5 Outlet	Pond Outlet	Upstream	7.201	17.100	10.94	APN5	Pond Inflow
APN5 Outlet	Pond Outlet	Outflow	3.758	20.600	5.01	APN5	Pond Outflow
APN5 Outlet	Pond Outlet	Link	3.758	20.600	5.01		
APN5 Outlet	Pond Outlet	Downstream	10.046	17.100	14.81	APN6	
APN6 Outlet	Pond Outlet	Upstream	10.046	17.100	14.81	APN6	Pond Inflow
APN6 Outlet	Pond Outlet	Outflow	2.688	24.000	5.47	APN6	Pond Outflow
APN6 Outlet	Pond Outlet	Link	2.688	24.000	5.47		
APN6 Outlet	Pond Outlet	Downstream	3.696	24.000	5.75	TAM2	
CO-3	Channel	Upstream	254.924	7.800	219.77	J-5	
CO-3	Channel	Link	254.924	7.900	219.77		
CO-3	Channel	Downstream	276.694	7.900	221.01	TAM1	
CO-4	Channel	Upstream	5.559	16.000	8.47	J-6	
CO-4	Channel	Link	5.559	16.100	8.47		
CO-4	Channel	Downstream	254.924	7.800	219.77	J-5	
North Pond Outlet	Pond Outlet	Upstream	0.560	16.000	0.84	North Pond	Pond Inflow
North Pond Outlet	Pond Outlet	Outflow	0.283	20.500	0.32	North Pond	Pond Outflow
North Pond Outlet	Negative Flow	Outflow	-0.003	9.400	-0.04	North Pond	Pond Outflow
North Pond Outlet	Pond Outlet	Link	0.283	20.500	0.32		
North Pond Outlet	Negative Flow	Link	-0.003	9.400	-0.04		
North Pond Outlet	Pond Outlet	Downstream	269.564	10.100	203.53	West Tributary - Clow Creek	
OFFSITE FLOW	Pond Outlet	Upstream	269.564	10.100	203.53	West Tributary - Clow Creek	Pond Inflow
OFFSITE FLOW	Pond Outlet	Outflow	268.986	10.200	203.51	West Tributary - Clow Creek	Pond Outflow
OFFSITE FLOW	Pond Outlet	Link	268.986	10.200	203.51		
OFFSITE FLOW	Pond Outlet	Downstream	268.986	10.200	203.51	CLOW CREEK OUTFALL OFF-SITE	

Scenario Calculation Summary

Executive Summary (Links)

Label	Type	Location	Hydrograph Volume (ac-ft)	Peak Time (hours)	Peak Flow (ft ³ /s)	End Point	Node Flow Direction
South Pond Outlet	Pond Outlet	Upstream	2.424	16.000	3.31	South Pond	Pond Inflow
South Pond Outlet	Pond Outlet	Outflow	0.282	24.000	0.30	South Pond	Pond Outflow
South Pond Outlet	Pond Outlet	Link	0.282	24.000	0.30		
South Pond Outlet	Pond Outlet	Downstream	269.564	10.100	203.53	West Tributary - Clow Creek	
TAM1 OUTLET	Pond Outlet	Upstream	276.694	7.900	221.01	TAM1	Pond Inflow
TAM1 OUTLET	Pond Outlet	Outflow	264.475	9.000	205.30	TAM1	Pond Outflow
TAM1 OUTLET	Pond Outlet	Link	263.551	9.000	205.30		
TAM1 OUTLET	Pond Outlet	Downstream	266.859	9.000	205.34	TAM6	
TAM2 Outlet	Pond Outlet	Upstream	3.696	24.000	5.75	TAM2	Pond Inflow
TAM2 Outlet	Pond Outlet	Outflow	2.885	24.000	5.58	TAM2	Pond Outflow
TAM2 Outlet	Pond Outlet	Link	2.885	24.000	5.58		
TAM2 Outlet	Pond Outlet	Downstream	4.344	24.000	5.98	TAM3	
TAM3 Outlet	Pond Outlet	Upstream	4.344	24.000	5.98	TAM3	Pond Inflow
TAM3 Outlet	Pond Outlet	Outflow	3.213	24.000	5.68	TAM3	Pond Outflow
TAM3 Outlet	Pond Outlet	Link	3.166	23.900	5.66		
TAM3 Outlet	Pond Outlet	Downstream	11.682	17.100	15.62	TAM4	
TAM4 Outlet	Pond Outlet	Upstream	11.682	17.100	15.62	TAM4	Pond Inflow
TAM4 Outlet	Pond Outlet	Outflow	5.971	20.600	9.27	TAM4	Pond Outflow
TAM4 Outlet	Pond Outlet	Link	5.971	20.600	9.27		
TAM4 Outlet	Pond Outlet	Downstream	7.444	20.100	10.07	TAM5	
TAM5 Outlet	Pond Outlet	Upstream	7.444	20.100	10.07	TAM5	Pond Inflow
TAM5 Outlet	Pond Outlet	Outflow	4.887	23.100	9.26	TAM5	Pond Outflow
TAM5 Outlet	Pond Outlet	Link	4.887	23.100	9.26		
TAM5 Outlet	Pond Outlet	Downstream	278.364	9.500	205.27	TAM7	
TAM6	Pond Outlet	Upstream	266.859	9.000	205.34	TAM6	Pond Inflow
TAM6	Pond Outlet	Outflow	264.413	9.500	203.85	TAM6	Pond Outflow
TAM6	Pond Outlet	Link	263.457	9.500	203.85		
TAM6	Pond Outlet	Downstream	278.364	9.500	205.27	TAM7	
TAM7 Outlet	Pond Outlet	Upstream	278.364	9.500	205.27	TAM7	Pond Inflow
TAM7 Outlet	Pond Outlet	Outflow	268.735	10.100	203.44	TAM7	Pond Outflow
TAM7 Outlet	Pond Outlet	Link	268.735	10.100	203.44		
TAM7 Outlet	Pond Outlet	Downstream	269.564	10.100	203.53	West Tributary - Clow Creek	

Messages

Message Id	29
Scenario	10Yr-24Hr
Element Type	Catchment
Element Id	7988
Label	101
Time	(N/A)
Message	Tm > .25Tp. Computation increment, Tm, is greater than 1/4 Time to Peak on Unit Hydrograph. Using a larger Tc can solve this problem.
Source	Warning

Scenario Calculation Summary

Messages

Message Id	39
Scenario	10Yr-24Hr
Element Type	Composite Outlet Structure
Element Id	7990
Label	Rev North Pond Outlet
Time	(N/A)
Message	Reverse flow conditions encountered for one or more headwater elevations. Calculated reverse flows may be approximate.
Source	Warning

Message Id	67
Scenario	10Yr-24Hr
Element Type	Composite Outlet Structure
Element Id	7699
Label	West Tributary Offsite Flow
Time	(N/A)
Message	Flow direction set to reverse for one ore more structures in composite outlet structure West Tributary Offsite Flow. To eliminate this warning, edit outlet data and select forward only. If reverse flow analysis is required, then the tailwater conditions must be set to interconnected pond.
Source	Warning

Message Id	39
Scenario	10Yr-24Hr
Element Type	Composite Outlet Structure
Element Id	7991
Label	South Pond Outlet
Time	(N/A)
Message	Reverse flow conditions encountered for one or more headwater elevations. Calculated reverse flows may be approximate.
Source	Warning

Scenario Calculation Summary

Scenario Summary	
ID	744
Label	100Yr-24Hr
Notes	
Active Topology	Base Active Topology
Hydrology	Base Hydrology
Rainfall Runoff	100Yr-24Hr
Physical	Base Physical
Initial Condition	Base Initial Condition
Boundary Condition	Base Boundary Condition
Infiltration and Inflow	Base Infiltration and Inflow
Output	Base Output
User Data Extensions	Base User Data Extensions
PondPack Engine Calculation Options	24Hr

Output Summary			
Output Increment	0.100 hours	Duration	120.000 hours

Rainfall Summary			
Return Event Tag	24 Hr	Rainfall Type	Time-Depth Curve
Total Depth	8.6 in	Storm Event	100YR-24HR

ICPM Output Summary			
Target Convergence	0.00 ft ³ /s	ICPM Time Step	0.100 hours
Maximum Iterations	35		

Executive Summary (Nodes)

Label	Scenario	Return Event (years)	Truncation	Hydrograph Volume (ac-ft)	Time to Peak (hours)	Peak Flow (ft ³ /s)	Maximum Water Surface Elevation (ft)	Maximum Pond Storage (ac-ft)
101	100Yr-24Hr	100	None	7.736	16.000	9.38	(N/A)	(N/A)
102	100Yr-24Hr	100	None	1.895	16.000	2.44	(N/A)	(N/A)
201	100Yr-24Hr	100	None	0.187	16.000	0.28	(N/A)	(N/A)
202	100Yr-24Hr	100	None	0.365	16.000	0.55	(N/A)	(N/A)
203	100Yr-24Hr	100	None	0.528	16.000	0.73	(N/A)	(N/A)
204	100Yr-24Hr	100	None	0.096	16.000	0.15	(N/A)	(N/A)
205	100Yr-24Hr	100	None	0.173	16.000	0.26	(N/A)	(N/A)
206	100Yr-24Hr	100	None	0.180	16.000	0.27	(N/A)	(N/A)
301	100Yr-24Hr	100	None	0.043	16.000	0.06	(N/A)	(N/A)
302	100Yr-24Hr	100	None	0.292	16.000	0.46	(N/A)	(N/A)
303	100Yr-24Hr	100	None	0.729	16.000	1.10	(N/A)	(N/A)
APN2	100Yr-24Hr	100	None	4.564	16.000	6.47	(N/A)	(N/A)
APN3	100Yr-24Hr	100	None	27.760	16.000	35.60	(N/A)	(N/A)
APN3 (IN)	100Yr-24Hr	100	None	27.760	16.000	35.60	(N/A)	(N/A)
APN3 (OUT)	100Yr-24Hr	100	None	27.560	20.000	14.00	684.84	14.710
APN4 (IN)	100Yr-24Hr	100	None	9.182	16.000	12.12	(N/A)	(N/A)
APN4 (OUT)	100Yr-24Hr	100	None	9.177	20.900	4.03	686.31	5.081
APN4	100Yr-24Hr	100	None	9.182	16.000	12.12	(N/A)	(N/A)
APN5 (IN)	100Yr-24Hr	100	None	30.435	16.100	31.46	(N/A)	(N/A)
APN5 (OUT)	100Yr-24Hr	100	None	30.283	16.300	31.22	681.22	8.223
APN5	100Yr-24Hr	100	None	21.258	16.100	28.10	(N/A)	(N/A)
APN6 (IN)	100Yr-24Hr	100	None	60.642	16.200	73.51	(N/A)	(N/A)
APN6 (OUT)	100Yr-24Hr	100	None	59.212	21.300	23.60	673.02	31.387

Scenario Calculation Summary

Executive Summary (Nodes)

Label	Scenario	Return Event (years)	Truncation	Hydrograph Volume (ac-ft)	Time to Peak (hours)	Peak Flow (ft ³ /s)	Maximum Water Surface Elevation (ft)	Maximum Pond Storage (ac-ft)
APN6	100Yr-24Hr	100	None	30.359	16.100	42.34	(N/A)	(N/A)
ASH4	100Yr-24Hr	100	None	2.383	16.000	3.15	(N/A)	(N/A)
CLOW CREEK OUTFALL OFF -SITE	100Yr-24Hr	100	None	963.869	19.100	397.43	(N/A)	(N/A)
CREEK OUTFALL 1	100Yr-24Hr	100	None	219.206	21.400	102.72	(N/A)	(N/A)
CREEK OUTFALL 2	100Yr-24Hr	100	None	469.501	0.100	168.35	(N/A)	(N/A)
J-5	100Yr-24Hr	100	None	714.668	18.000	251.81	(N/A)	(N/A)
J-6	100Yr-24Hr	100	None	21.397	16.000	28.07	(N/A)	(N/A)
North Pond (IN)	100Yr-24Hr	100	None	2.188	16.000	2.89	(N/A)	(N/A)
North Pond (OUT)	100Yr-24Hr	100	None	2.188	17.200	1.37	653.30	1.002
Offsite Runoff (East)	100Yr-24Hr	100	None	0.096	16.000	0.15	(N/A)	(N/A)
Offsite Runoff (South)	100Yr-24Hr	100	None	0.528	16.000	0.73	(N/A)	(N/A)
PR1	100Yr-24Hr	100	None	10.630	16.000	13.93	(N/A)	(N/A)
PR2	100Yr-24Hr	100	None	5.239	16.000	6.87	(N/A)	(N/A)
PR3	100Yr-24Hr	100	None	3.146	16.000	4.12	(N/A)	(N/A)
South Pond (IN)	100Yr-24Hr	100	None	7.736	16.000	9.38	(N/A)	(N/A)
South Pond (OUT)	100Yr-24Hr	100	None	6.578	24.000	1.34	654.40	6.427
TAM1 (IN)	100Yr-24Hr	100	None	814.483	17.100	346.76	(N/A)	(N/A)
TAM1 (OUT)	100Yr-24Hr	100	None	807.392	18.400	323.59	664.41	25.196
TAM1	100Yr-24Hr	100	None	72.626	16.000	96.74	(N/A)	(N/A)
TAM2 (IN)	100Yr-24Hr	100	None	62.939	21.100	24.71	(N/A)	(N/A)
TAM2 (OUT)	100Yr-24Hr	100	None	62.774	21.700	23.86	665.88	2.991
TAM2	100Yr-24Hr	100	None	3.727	16.000	4.82	(N/A)	(N/A)
TAM3 (IN)	100Yr-24Hr	100	None	68.301	21.700	25.30	(N/A)	(N/A)
TAM3 (OUT)	100Yr-24Hr	100	None	68.084	22.300	25.75	665.36	4.605
TAM3	100Yr-24Hr	100	None	5.527	16.000	7.19	(N/A)	(N/A)
TAM4 (IN)	100Yr-24Hr	100	None	100.789	16.000	57.70	(N/A)	(N/A)
TAM4 (OUT)	100Yr-24Hr	100	None	99.543	20.200	39.31	664.94	19.586
TAM4	100Yr-24Hr	100	None	32.705	16.100	42.56	(N/A)	(N/A)
TAM5 (IN)	100Yr-24Hr	100	None	104.677	19.100	42.21	(N/A)	(N/A)
TAM5 (OUT)	100Yr-24Hr	100	None	103.953	20.600	40.89	661.03	6.701
TAM5	100Yr-24Hr	100	None	5.134	16.000	6.45	(N/A)	(N/A)
TAM6 (IN)	100Yr-24Hr	100	None	818.982	18.200	334.24	(N/A)	(N/A)
TAM6 (OUT)	100Yr-24Hr	100	None	817.862	18.900	328.88	658.73	7.127
TAM6	100Yr-24Hr	100	None	11.590	16.000	16.35	(N/A)	(N/A)
TAM7 (IN)	100Yr-24Hr	100	None	959.665	18.400	396.39	(N/A)	(N/A)
TAM7 (OUT)	100Yr-24Hr	100	None	953.644	19.100	393.52	655.38	16.159
TAM7	100Yr-24Hr	100	None	37.850	16.100	50.65	(N/A)	(N/A)
West Tributary - Clow Creek (IN)	100Yr-24Hr	100	None	964.086	19.100	397.50	(N/A)	(N/A)

Scenario Calculation Summary

Executive Summary (Nodes)

Label	Scenario	Return Event (years)	Truncation	Hydrograph Volume (ac-ft)	Time to Peak (hours)	Peak Flow (ft ³ /s)	Maximum Water Surface Elevation (ft)	Maximum Pond Storage (ac-ft)
West Tributary - Clow Creek (OUT)	100Yr-24Hr	100	None	963.869	19.100	397.43	650.39	0.273

Executive Summary (Links)

Label	Type	Location	Hydrograph Volume (ac-ft)	Peak Time (hours)	Peak Flow (ft ³ /s)	End Point	Node Flow Direction
APN3 Outlet	Pond Outlet	Upstream	27.760	16.000	35.60	APN3	Pond Inflow
APN3 Outlet	Pond Outlet	Outflow	27.560	20.000	14.00	APN3	Pond Outflow
APN3 Outlet	Pond Outlet	Link	27.560	20.000	14.00		
APN3 Outlet	Pond Outlet	Downstream	814.483	17.100	346.76	TAM1	
APN4 Outlet	Pond Outlet	Upstream	9.182	16.000	12.12	APN4	Pond Inflow
APN4 Outlet	Pond Outlet	Outflow	9.177	20.900	4.03	APN4	Pond Outflow
APN4 Outlet	Pond Outlet	Link	9.177	20.900	4.03		
APN4 Outlet	Pond Outlet	Downstream	30.435	16.100	31.46	APN5	
APN5 Outlet	Pond Outlet	Upstream	30.435	16.100	31.46	APN5	Pond Inflow
APN5 Outlet	Pond Outlet	Outflow	30.283	16.300	31.22	APN5	Pond Outflow
APN5 Outlet	Pond Outlet	Link	30.283	16.300	31.22		
APN5 Outlet	Pond Outlet	Downstream	60.642	16.200	73.51	APN6	
APN6 Outlet	Pond Outlet	Upstream	60.642	16.200	73.51	APN6	Pond Inflow
APN6 Outlet	Pond Outlet	Outflow	59.212	21.300	23.60	APN6	Pond Outflow
APN6 Outlet	Pond Outlet	Link	59.212	21.300	23.60		
APN6 Outlet	Pond Outlet	Downstream	62.939	21.100	24.71	TAM2	
CO-3	Channel	Upstream	714.668	18.000	251.81	J-5	
CO-3	Channel	Link	714.668	18.100	251.81		
CO-3	Channel	Downstream	814.483	17.100	346.76	TAM1	
CO-4	Channel	Upstream	21.397	16.000	28.07	J-6	
CO-4	Channel	Link	21.397	16.100	28.07		
CO-4	Channel	Downstream	714.668	18.000	251.81	J-5	
North Pond Outlet	Pond Outlet	Upstream	2.188	16.000	2.89	North Pond	Pond Inflow
North Pond Outlet	Pond Outlet	Outflow	2.188	17.200	1.37	North Pond	Pond Outflow
North Pond Outlet	Pond Outlet	Link	2.187	17.200	1.37		
North Pond Outlet	Pond Outlet	Downstream	964.086	19.100	397.50	West Tributary - Clow Creek	
OFFSITE FLOW	Pond Outlet	Upstream	964.086	19.100	397.50	West Tributary - Clow Creek	Pond Inflow
OFFSITE FLOW	Pond Outlet	Outflow	963.869	19.100	397.43	West Tributary - Clow Creek	Pond Outflow
OFFSITE FLOW	Pond Outlet	Link	963.869	19.100	397.43		
OFFSITE FLOW	Pond Outlet	Downstream	963.869	19.100	397.43	CLOW CREEK OUTFALL OFF-SITE	
South Pond Outlet	Pond Outlet	Upstream	7.736	16.000	9.38	South Pond	Pond Inflow
South Pond Outlet	Pond Outlet	Outflow	6.578	24.000	1.34	South Pond	Pond Outflow

Scenario Calculation Summary

Executive Summary (Links)

Label	Type	Location	Hydrograph Volume (ac-ft)	Peak Time (hours)	Peak Flow (ft ³ /s)	End Point	Node Flow Direction
South Pond Outlet	Pond Outlet	Link	6.576	24.000	1.34		
South Pond Outlet	Pond Outlet	Downstream	964.086	19.100	397.50	West Tributary - Clow Creek	
TAM1 OUTLET	Pond Outlet	Upstream	814.483	17.100	346.76	TAM1	Pond Inflow
TAM1 OUTLET	Pond Outlet	Outflow	807.392	18.400	323.59	TAM1	Pond Outflow
TAM1 OUTLET	Pond Outlet	Link	807.392	18.400	323.59		
TAM1 OUTLET	Pond Outlet	Downstream	818.982	18.200	334.24	TAM6	
TAM2 Outlet	Pond Outlet	Upstream	62.939	21.100	24.71	TAM2	Pond Inflow
TAM2 Outlet	Pond Outlet	Outflow	62.774	21.700	23.86	TAM2	Pond Outflow
TAM2 Outlet	Pond Outlet	Link	62.774	21.700	23.86		
TAM2 Outlet	Pond Outlet	Downstream	68.301	21.700	25.30	TAM3	
TAM3 Outlet	Pond Outlet	Upstream	68.301	21.700	25.30	TAM3	Pond Inflow
TAM3 Outlet	Pond Outlet	Outflow	68.084	22.300	25.75	TAM3	Pond Outflow
TAM3 Outlet	Pond Outlet	Link	68.081	22.300	25.75		
TAM3 Outlet	Pond Outlet	Downstream	100.789	16.000	57.70	TAM4	
TAM4 Outlet	Pond Outlet	Upstream	100.789	16.000	57.70	TAM4	Pond Inflow
TAM4 Outlet	Pond Outlet	Outflow	99.543	20.200	39.31	TAM4	Pond Outflow
TAM4 Outlet	Pond Outlet	Link	99.539	20.200	39.31		
TAM4 Outlet	Pond Outlet	Downstream	104.677	19.100	42.21	TAM5	
TAM5 Outlet	Pond Outlet	Upstream	104.677	19.100	42.21	TAM5	Pond Inflow
TAM5 Outlet	Pond Outlet	Outflow	103.953	20.600	40.89	TAM5	Pond Outflow
TAM5 Outlet	Pond Outlet	Link	103.953	20.600	40.89		
TAM5 Outlet	Pond Outlet	Downstream	959.665	18.400	396.39	TAM7	
TAM6	Pond Outlet	Upstream	818.982	18.200	334.24	TAM6	Pond Inflow
TAM6	Pond Outlet	Outflow	817.862	18.900	328.88	TAM6	Pond Outflow
TAM6	Pond Outlet	Link	817.862	18.900	328.88		
TAM6	Pond Outlet	Downstream	959.665	18.400	396.39	TAM7	
TAM7 Outlet	Pond Outlet	Upstream	959.665	18.400	396.39	TAM7	Pond Inflow
TAM7 Outlet	Pond Outlet	Outflow	953.644	19.100	393.52	TAM7	Pond Outflow
TAM7 Outlet	Pond Outlet	Link	953.236	19.100	393.52		
TAM7 Outlet	Pond Outlet	Downstream	964.086	19.100	397.50	West Tributary - Clow Creek	

Messages

Message Id	29
Scenario	100 Yr-12Hr
Element Type	Catchment
Element Id	7988
Label	101
Time	(N/A)
Message	Tm > .25Tp. Computation increment, Tm, is greater than 1/4 Time to Peak on Unit Hydrograph. Using a larger Tc can solve this problem.
Source	Warning

Scenario Calculation Summary

Messages

Message Id	39
Scenario	100 Yr-12Hr
Element Type	Composite Outlet Structure
Element Id	7990
Label	Rev North Pond Outlet
Time	(N/A)
Message	Reverse flow conditions encountered for one or more headwater elevations. Calculated reverse flows may be approximate.
Source	Warning

Message Id	39
Scenario	100Yr-6Hr
Element Type	Composite Outlet Structure
Element Id	7990
Label	Rev North Pond Outlet
Time	(N/A)
Message	Reverse flow conditions encountered for one or more headwater elevations. Calculated reverse flows may be approximate.
Source	Warning

Message Id	39
Scenario	100Yr-3Hr
Element Type	Composite Outlet Structure
Element Id	7990
Label	Rev North Pond Outlet
Time	(N/A)
Message	Reverse flow conditions encountered for one or more headwater elevations. Calculated reverse flows may be approximate.
Source	Warning

Message Id	39
Scenario	100Yr-2Hr
Element Type	Composite Outlet Structure
Element Id	7990
Label	Rev North Pond Outlet
Time	(N/A)
Message	Reverse flow conditions encountered for one or more headwater elevations. Calculated reverse flows may be approximate.
Source	Warning

Message Id	39
Scenario	100Yr-1Hr
Element Type	Composite Outlet Structure
Element Id	7990
Label	Rev North Pond Outlet
Time	(N/A)
Message	Reverse flow conditions encountered for one or more headwater elevations. Calculated reverse flows may be approximate.
Source	Warning

Message Id	67
Scenario	100 Yr-12Hr
Element Type	Composite Outlet Structure
Element Id	7699
Label	West Tributary Offsite Flow
Time	(N/A)
Message	Flow direction set to reverse for one ore more structures in composite outlet structure West Tributary Offsite Flow. To eliminate this warning, edit outlet data and select forward only. If reverse flow analysis is required, then the tailwater conditions must be set to interconnected pond.
Source	Warning

Scenario Calculation Summary

Messages

Message Id	67
Scenario	100Yr-6Hr
Element Type	Composite Outlet Structure
Element Id	7699
Label	West Tributary Offsite Flow
Time	(N/A)
Message	Flow direction set to reverse for one ore more structures in composite outlet structure West Tributary Offsite Flow. To eliminate this warning, edit outlet data and select forward only. If reverse flow analysis is required, then the tailwater conditions must be set to interconnected pond.
Source	Warning

Message Id	67
Scenario	100Yr-3Hr
Element Type	Composite Outlet Structure
Element Id	7699
Label	West Tributary Offsite Flow
Time	(N/A)
Message	Flow direction set to reverse for one ore more structures in composite outlet structure West Tributary Offsite Flow. To eliminate this warning, edit outlet data and select forward only. If reverse flow analysis is required, then the tailwater conditions must be set to interconnected pond.
Source	Warning

Message Id	67
Scenario	100Yr-2Hr
Element Type	Composite Outlet Structure
Element Id	7699
Label	West Tributary Offsite Flow
Time	(N/A)
Message	Flow direction set to reverse for one ore more structures in composite outlet structure West Tributary Offsite Flow. To eliminate this warning, edit outlet data and select forward only. If reverse flow analysis is required, then the tailwater conditions must be set to interconnected pond.
Source	Warning

Message Id	67
Scenario	100Yr-1Hr
Element Type	Composite Outlet Structure
Element Id	7699
Label	West Tributary Offsite Flow
Time	(N/A)
Message	Flow direction set to reverse for one ore more structures in composite outlet structure West Tributary Offsite Flow. To eliminate this warning, edit outlet data and select forward only. If reverse flow analysis is required, then the tailwater conditions must be set to interconnected pond.
Source	Warning

Message Id	39
Scenario	100 Yr-12Hr
Element Type	Composite Outlet Structure
Element Id	7991
Label	South Pond Outlet
Time	(N/A)
Message	Reverse flow conditions encountered for one or more headwater elevations. Calculated reverse flows may be approximate.
Source	Warning

Scenario Calculation Summary

Messages

Message Id	39
Scenario	100Yr-6Hr
Element Type	Composite Outlet Structure
Element Id	7991
Label	South Pond Outlet
Time	(N/A)
Message	Reverse flow conditions encountered for one or more headwater elevations. Calculated reverse flows may be approximate.
Source	Warning

Message Id	39
Scenario	100Yr-3Hr
Element Type	Composite Outlet Structure
Element Id	7991
Label	South Pond Outlet
Time	(N/A)
Message	Reverse flow conditions encountered for one or more headwater elevations. Calculated reverse flows may be approximate.
Source	Warning

Message Id	39
Scenario	100Yr-2Hr
Element Type	Composite Outlet Structure
Element Id	7991
Label	South Pond Outlet
Time	(N/A)
Message	Reverse flow conditions encountered for one or more headwater elevations. Calculated reverse flows may be approximate.
Source	Warning

Message Id	39
Scenario	100Yr-1Hr
Element Type	Composite Outlet Structure
Element Id	7991
Label	South Pond Outlet
Time	(N/A)
Message	Reverse flow conditions encountered for one or more headwater elevations. Calculated reverse flows may be approximate.
Source	Warning

Message Id	29
Scenario	100Yr-18Hr
Element Type	Catchment
Element Id	7988
Label	101
Time	(N/A)
Message	$T_m > .25T_p$. Computation increment, T_m , is greater than 1/4 Time to Peak on Unit Hydrograph. Using a larger T_c can solve this problem.
Source	Warning

Message Id	39
Scenario	100Yr-18Hr
Element Type	Composite Outlet Structure
Element Id	7990
Label	Rev North Pond Outlet
Time	(N/A)
Message	Reverse flow conditions encountered for one or more headwater elevations. Calculated reverse flows may be approximate.
Source	Warning

Scenario Calculation Summary

Messages

Message Id	67
Scenario	100Yr-18Hr
Element Type	Composite Outlet Structure
Element Id	7699
Label	West Tributary Offsite Flow
Time	(N/A)
Message	Flow direction set to reverse for one ore more structures in composite outlet structure West Tributary Offsite Flow. To eliminate this warning, edit outlet data and select forward only. If reverse flow analysis is required, then the tailwater conditions must be set to interconnected pond.
Source	Warning

Message Id	39
Scenario	100Yr-18Hr
Element Type	Composite Outlet Structure
Element Id	7991
Label	South Pond Outlet
Time	(N/A)
Message	Reverse flow conditions encountered for one or more headwater elevations. Calculated reverse flows may be approximate.
Source	Warning

Message Id	40
Scenario	100Yr-18Hr
Element Type	Pond
Element Id	495
Label	TAM3
Time	(N/A)
Message	Mass balance for routing volumes vary by more than 0.5 %. (0.7 % of Inflow Volume))
Source	Warning

Message Id	40
Scenario	100Yr-18Hr
Element Type	Pond
Element Id	501
Label	TAM5
Time	(N/A)
Message	Mass balance for routing volumes vary by more than 0.5 %. (0.6 % of Inflow Volume))
Source	Warning

Message Id	29
Scenario	100Yr-24Hr
Element Type	Catchment
Element Id	7988
Label	101
Time	(N/A)
Message	$T_m > .25T_p$. Computation increment, T_m , is greater than 1/4 Time to Peak on Unit Hydrograph. Using a larger T_c can solve this problem.
Source	Warning

Message Id	39
Scenario	100Yr-24Hr
Element Type	Composite Outlet Structure
Element Id	7990
Label	Rev North Pond Outlet
Time	(N/A)
Message	Reverse flow conditions encountered for one or more headwater elevations. Calculated reverse flows may be approximate.
Source	Warning

Scenario Calculation Summary

Messages

Message Id 67
Scenario 100Yr-24Hr
Element Type Composite Outlet Structure
Element Id 7699
Label West Tributary Offsite Flow
Time (N/A)
Message Flow direction set to reverse for one ore more structures in composite outlet structure West Tributary Offsite Flow. To eliminate this warning, edit outlet data and select forward only. If reverse flow analysis is required, then the tailwater conditions must be set to interconnected pond.

Source Warning

Message Id 39
Scenario 100Yr-24Hr
Element Type Composite Outlet Structure
Element Id 7991
Label South Pond Outlet
Time (N/A)
Message Reverse flow conditions encountered for one or more headwater elevations. Calculated reverse flows may be approximate.

Source Warning

Message Id 29
Scenario 100Yr-48Hr
Element Type Catchment
Element Id 7988
Label 101
Time (N/A)
Message $T_m > .25T_p$. Computation increment, T_m , is greater than 1/4 Time to Peak on Unit Hydrograph. Using a larger T_c can solve this problem.

Source Warning

Message Id 39
Scenario 100Yr-48Hr
Element Type Composite Outlet Structure
Element Id 7990
Label Rev North Pond Outlet
Time (N/A)
Message Reverse flow conditions encountered for one or more headwater elevations. Calculated reverse flows may be approximate.

Source Warning

Message Id 67
Scenario 100Yr-48Hr
Element Type Composite Outlet Structure
Element Id 7699
Label West Tributary Offsite Flow
Time (N/A)
Message Flow direction set to reverse for one ore more structures in composite outlet structure West Tributary Offsite Flow. To eliminate this warning, edit outlet data and select forward only. If reverse flow analysis is required, then the tailwater conditions must be set to interconnected pond.

Source Warning

Message Id 39
Scenario 100Yr-48Hr
Element Type Composite Outlet Structure
Element Id 7991
Label South Pond Outlet
Time (N/A)
Message Reverse flow conditions encountered for one or more headwater elevations. Calculated reverse flows may be approximate.

Source Warning

Scenario Calculation Summary

Messages

Message Id	60
Scenario	100Yr-48Hr
Element Type	Conduit
Element Id	5382
Label	CO-4
Time	(N/A)
Message	Translation step is less than output time step. Translation step= 0.100 hours, Main output step= 0.200 hours. Translation step set equal to main output step.
Source	Warning

Message Id	60
Scenario	100Yr-48Hr
Element Type	Conduit
Element Id	5365
Label	CO-3
Time	(N/A)
Message	Translation step is less than output time step. Translation step= 0.100 hours, Main output step= 0.200 hours. Translation step set equal to main output step.
Source	Warning

EXHIBIT O

FLOODPLAIN CUT/FILL CALCULATIONS

Job #: 904.411
 Project: 111th Street

Date:
 Revised:
 By:

FLOODPLAIN CUT & FILL CALCULATIONS								
STATION	LENGTH (FT)	0-10 YEAR FLOODPLAIN CUT AND FILL CALCULATION				10-100 YEAR FLOODPLAIN CUT AND FILL CALCULATION		
		CROSS-SECTIONAL FILL (SF)	CROSS-SECTIONAL CUT (SF)	CROSS-SECTIONAL FILL VOLUME (CF)	CROSS-SECTIONAL CUT VOLUME (CF)	CROSS-SECTIONAL FILL (SF)	CROSS-SECTIONAL CUT (SF)	CROSS-SECTIONAL FILL VOLUME (CF)
		10 YR	10 YR	10 YR	10 YR	100 YR	100 YR	100 YR
0+00		0.0	0.0			0.0	0.0	
1+00	100	0.0	52.7	0.0	2633.3	0.0	21.3	0.0
2+00	100	0.0	11.5	0.0	3208.3	0.0	5.8	0.0
3+00	100	0.0	16.7	0.0	1408.3	0.0	10.0	0.0
4+00	100	0.0	38.0	0.0	2733.3	0.0	26.3	0.0
4+50	50	0.3	0.0	8.3	950.0	0.5	0.0	12.5
5+00	50	11.7	0.5	300.0	12.5	6.0	0.5	162.5
6+00	100	0.0	0.3	583.3	41.7	0.2	1.0	308.3
6+63.7	63.7	0.0	0.0	0.0	10.6	0.0	0.0	5.3
TOTAL (CF)				891.7	10998.1			488.6
TOTAL (CY)				33	407			18
TOTAL REQ'D COMPENSATORY STORAGE (CY)				33				18

10 CY CUT:	407	CY
10 CY Fill:	33	CY
100 CY CUT:	215	CY
100 CY Fill:	18	CY
Total Fill:	51	CY
Total Cut:	623	CY
Ratio Cut/Full (x:1):	12.18	CY

March 23, 2022

MAM

LOCATION
CROSS-SECTIONAL CUT VOLUME (CF)
100 YR
1066.7
1358.3
791.7
1816.7
658.3
12.5
75.0
31.9
5811.0
215