

NAPERVILLE, IL E-BOX PLUS

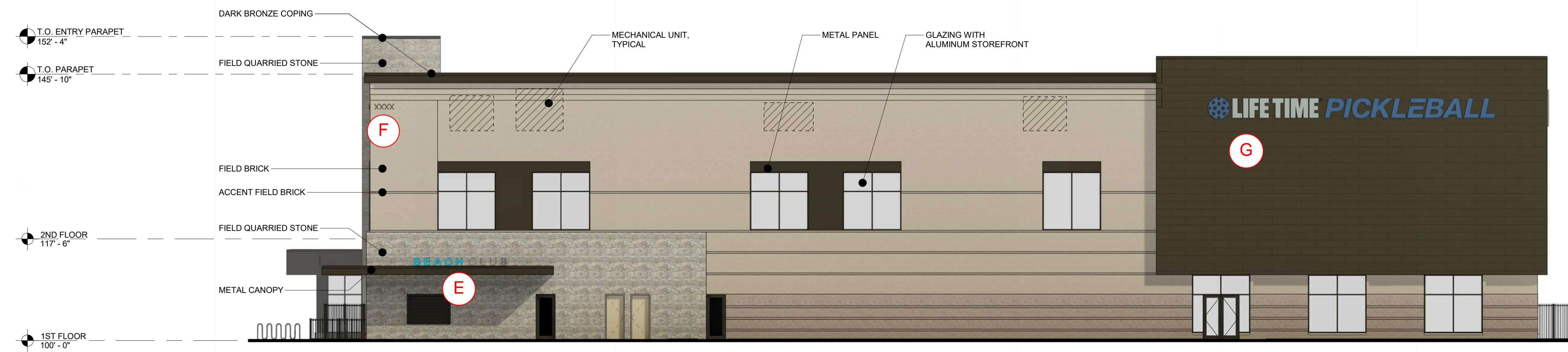



4 EXTERIOR ELEVATION - WEST  
3/32" = 1'-0"



3 EXTERIOR ELEVATION - SOUTH  
3/32" = 1'-0"

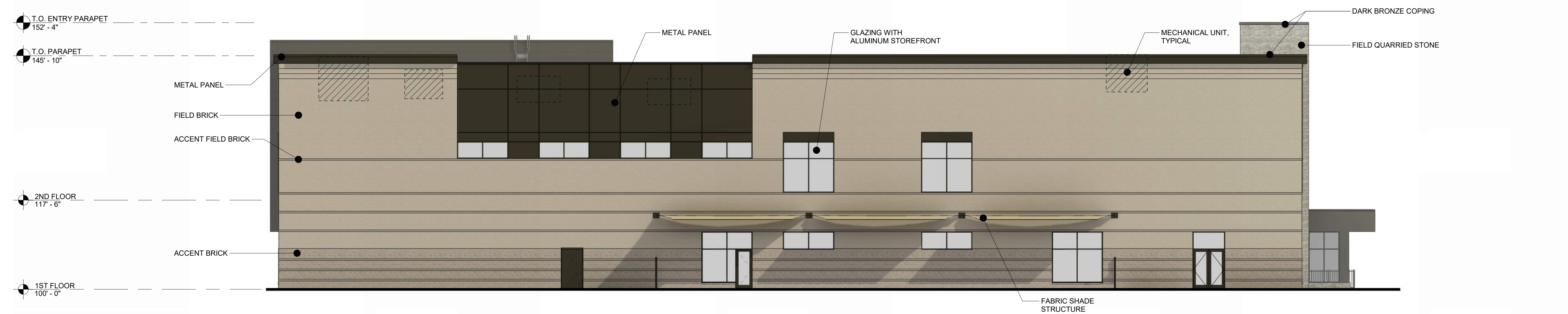

2 EXTERIOR ELEVATION - EAST  
3/32" = 1'-0"



1 EXTERIOR ELEVATION - NORTH  
3/32" = 1'-0"

# NAPERVILLE, IL E-BOX PLUS



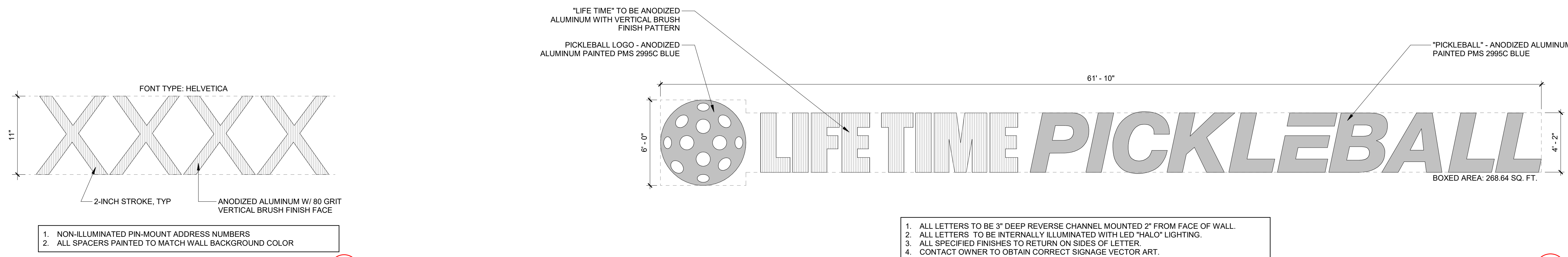

**C1** SIGN "F" - ADDRESS SIGN  
1 1/2" = 1'-0"

**C2** SIGN "G" - PICKLEBALL - EXTERIOR  
1/4" = 1'-0"  
DATE LAST MODIFIED: 11/14/2023

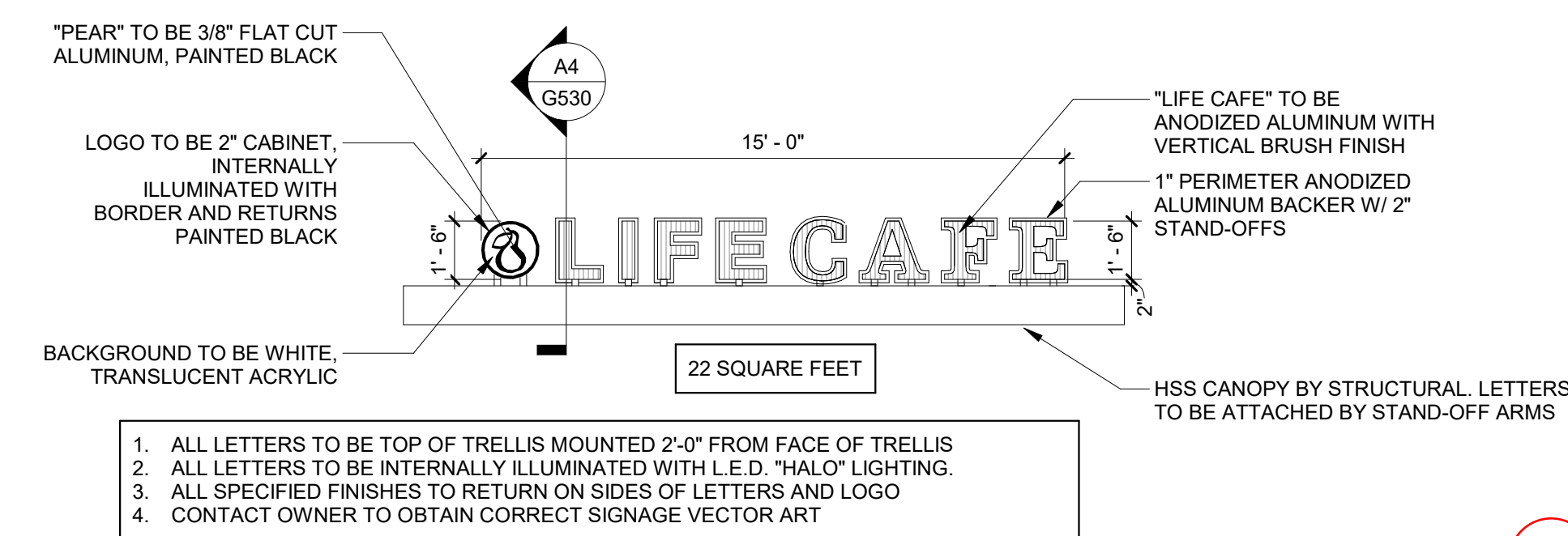

**B1** SIGN "C" - LIFE CAFE SIGNAGE  
1/4" = 1'-0"

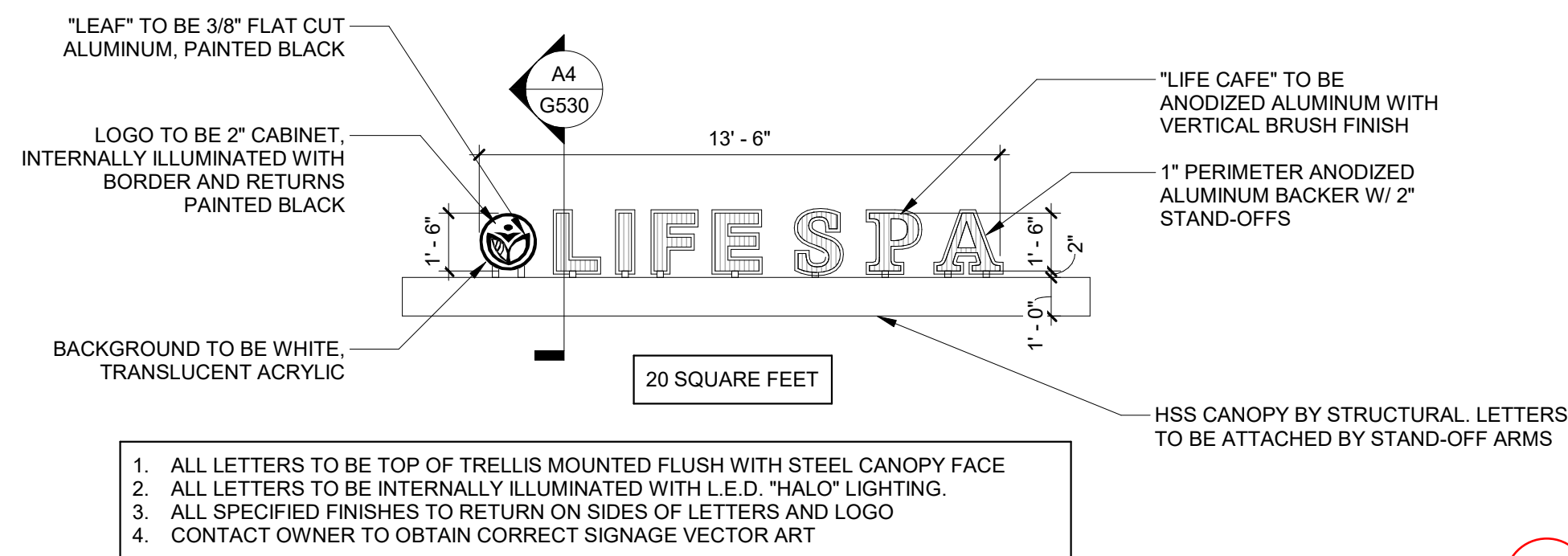

**B3** SIGN "D" - LIFE SPA SIGNAGE  
1/4" = 1'-0"

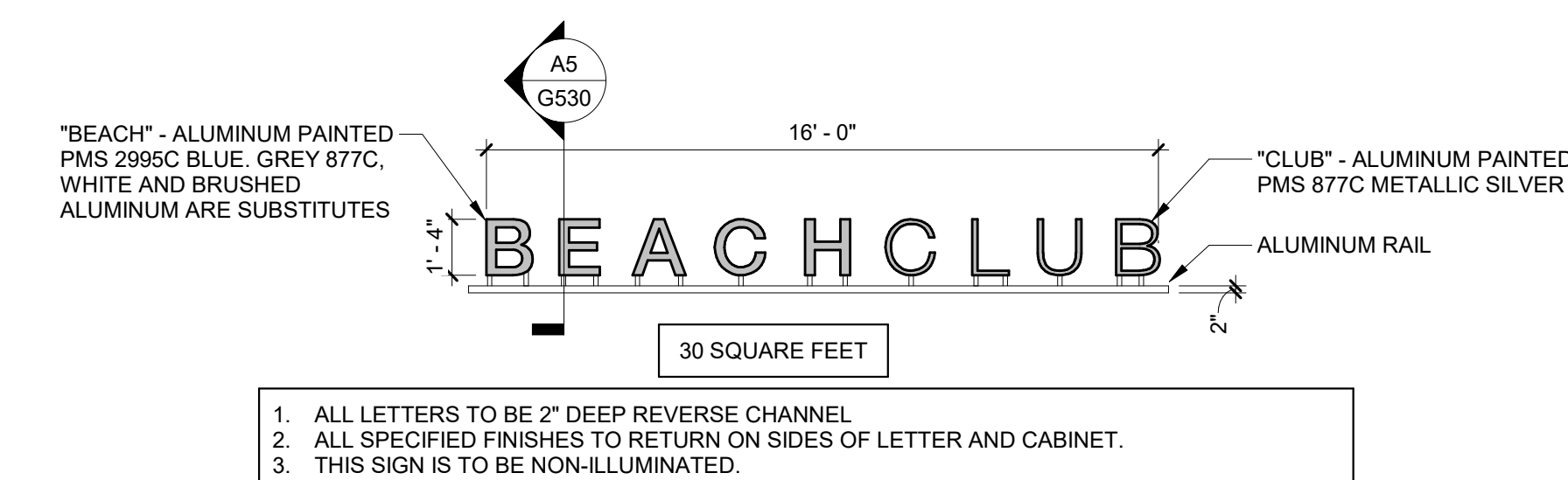

**B5** SIGN "E" - BEACH CLUB SIGNAGE  
1/4" = 1'-0"

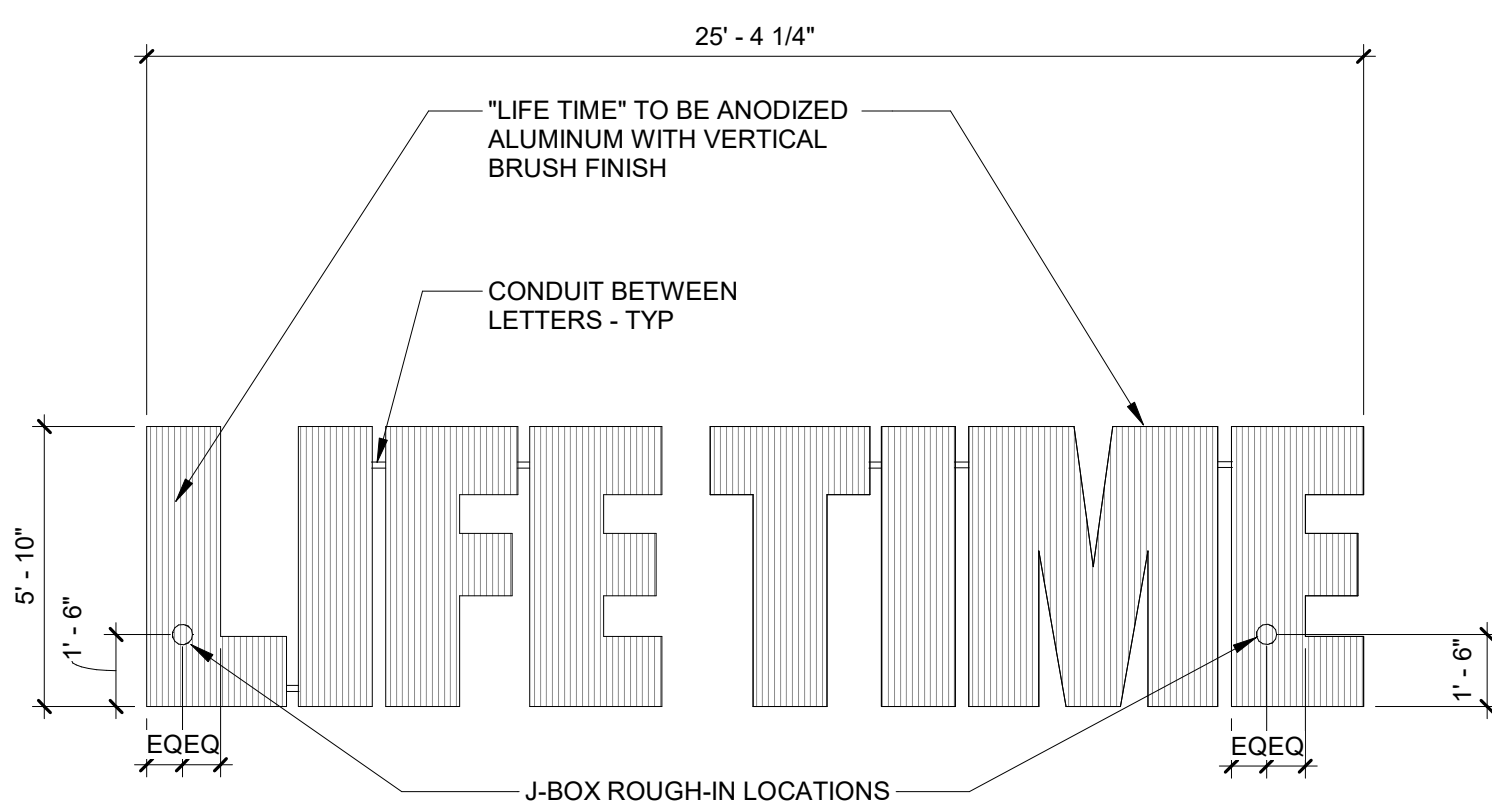

**A1** SIGN "A" - LIFE TIME BUILDING SIGNAGE  
1/4" = 1'-0"

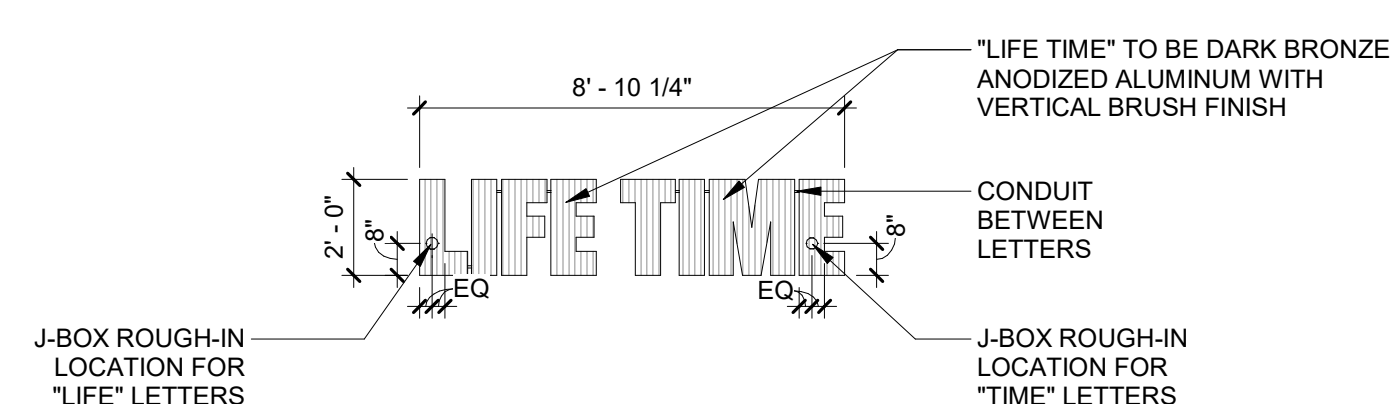

**A3** SIGN "B" - MONUMENT SIGNAGE  
1/4" = 1'-0"

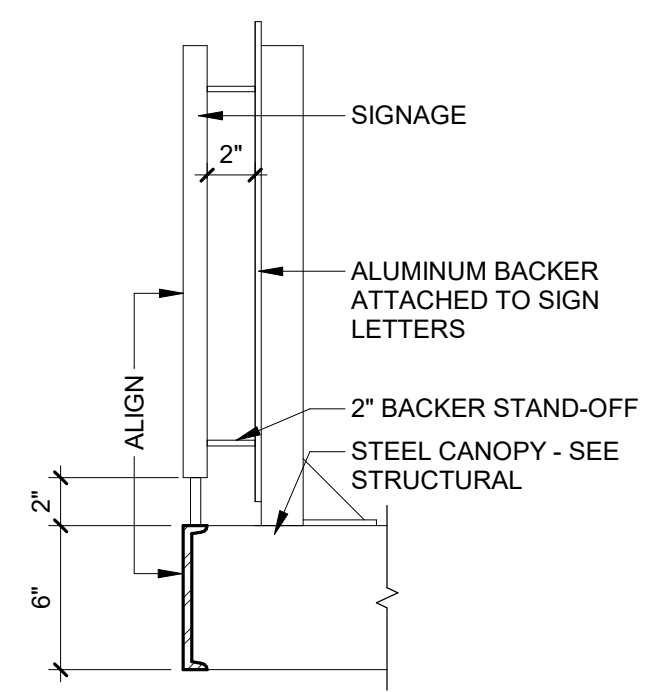

**A4** CANOPY SIGN ATTACHMENT 3  
1 1/2" = 1'-0"

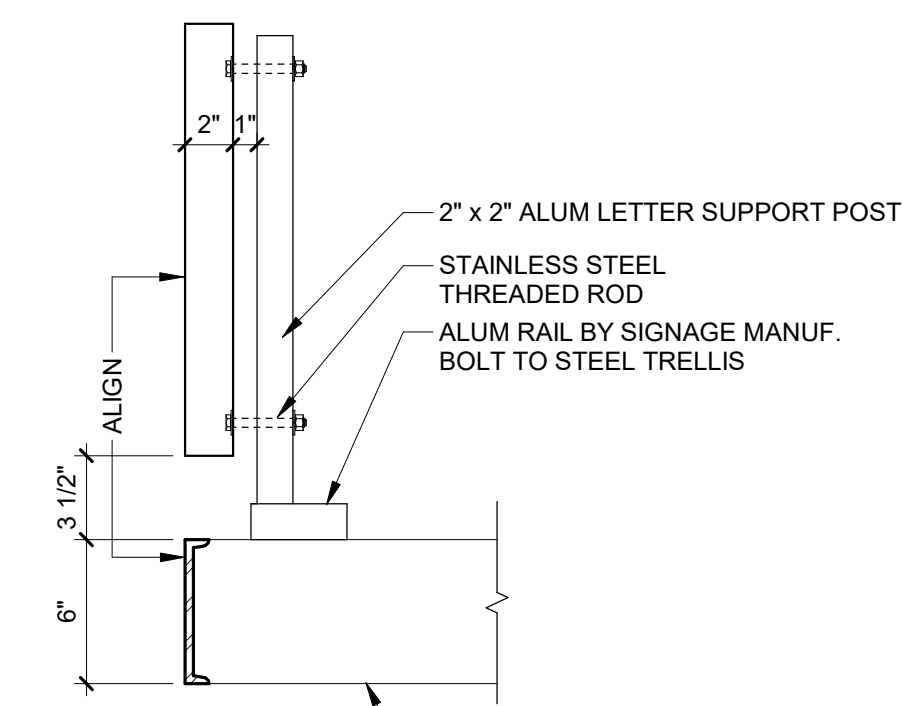

**A5** CANOPY SIGN ATTACHMENT - TRELLIS  
1 1/2" = 1'-0"

E  
D  
C  
B  
A