

1 REFUSE ENCLOSURE WEST ELEVATION
N.T.S.

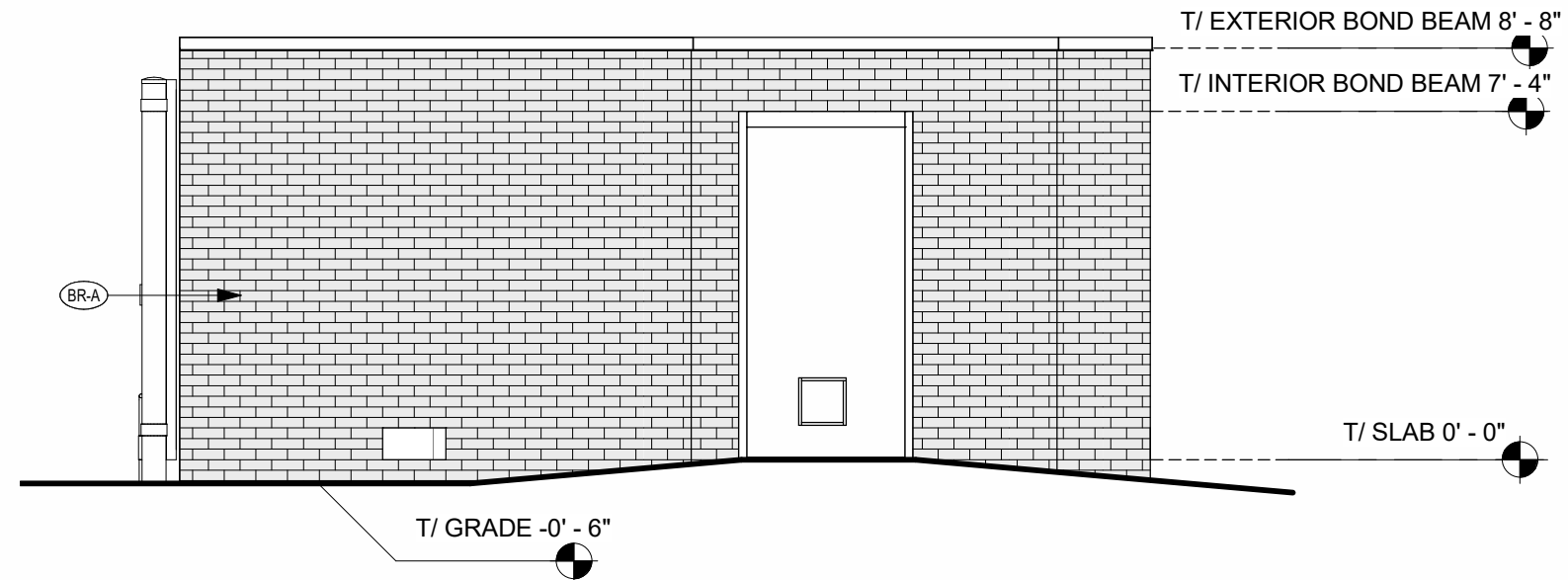

2 REFUSE ENCLOSURE SOUTH ELEVATION
N.T.S.

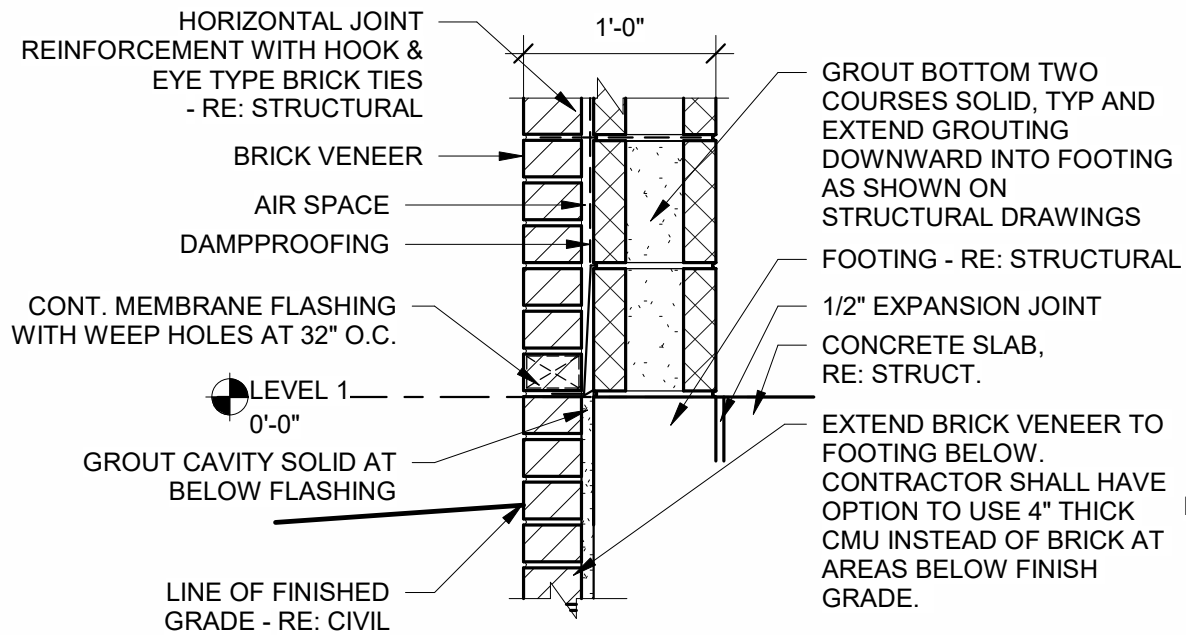

3 REFUSE ENCLOSURE BASE DETAIL
N.T.S.

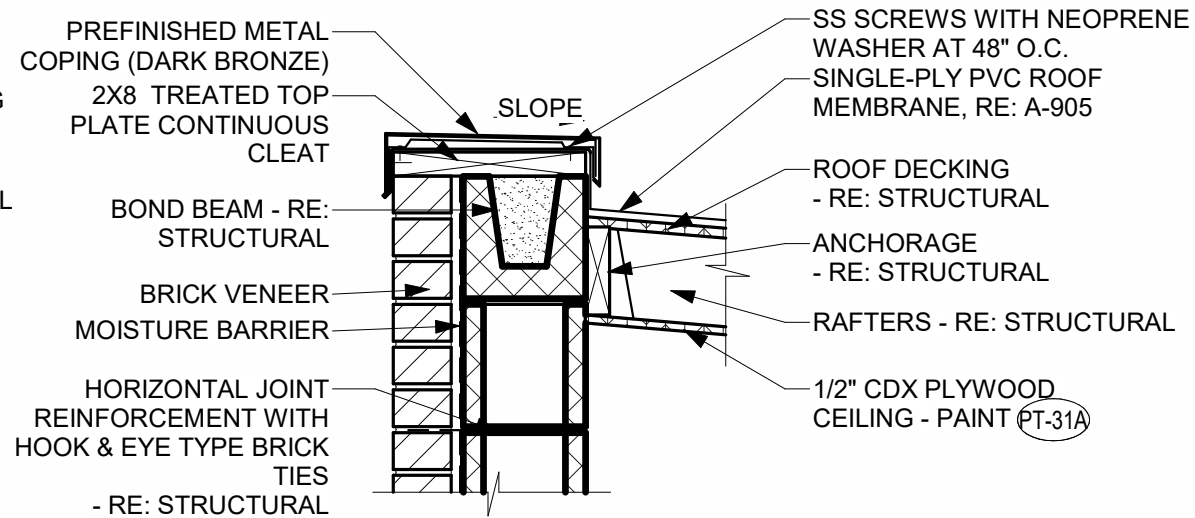

4 REFUSE ENCLOSURE ROOF EDGE DETAIL
N.T.S.

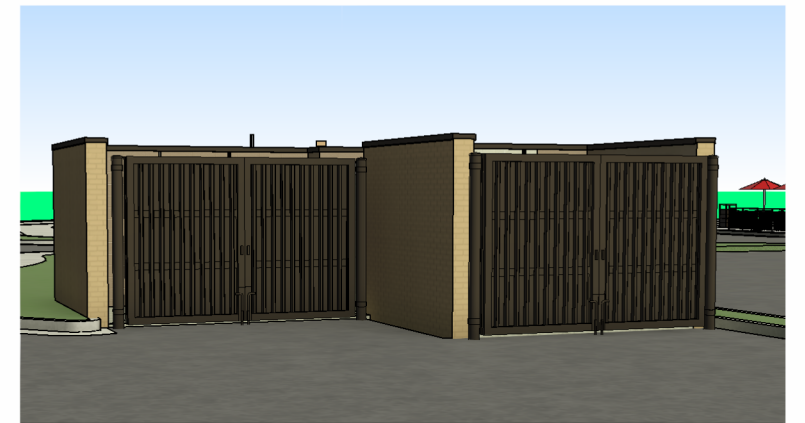

5 PERSPECTIVE VIEW

City Submittal - Refuse Enclosure

05590, OGDEN & IROQUOIS, 1163 Ogden Ave, Naperville, IL 60563

01/07/2024

THE CHICK-FIL-A DESIGN DEVELOPMENT PACKAGE REPRESENTS A BRAND COMPLIANT DESIGN SOLUTION. SITE ADAPT PROFESSIONALS ARE RESPONSIBLE FOR APPLICATION OF DESIGN AND COMPLIANCE WITH ORDINANCES AND CODES.



1/24/2024 2:41:54 PM
DD - 03