

# PRELIMINARY ENGINEERING PLAN FOR NAPER COMMONS

## PARCEL DESCRIPTION

LOT 4 IN NOKIA CAMPUS SUBDIVISION, BEING A SUBDIVISION IN PART OF THE NORTH 1/2 OF SECTION 5, TOWNSHIP 38 NORTH, RANGE 10 EAST AND THE SOUTH HALF OF SECTION 32, TOWNSHIP 39 NORTH RANGE 10 EAST OF THE THIRD PRINCIPAL MERIDIAN, ACCORDING TO THE PLAT THEREOF RECORDED AUGUST 6, 2020 AS DOCUMENT R2020-085330, IN DUPAGE COUNTY, ILLINOIS.



150 75 0 150  
SCALE: 1" = 150'

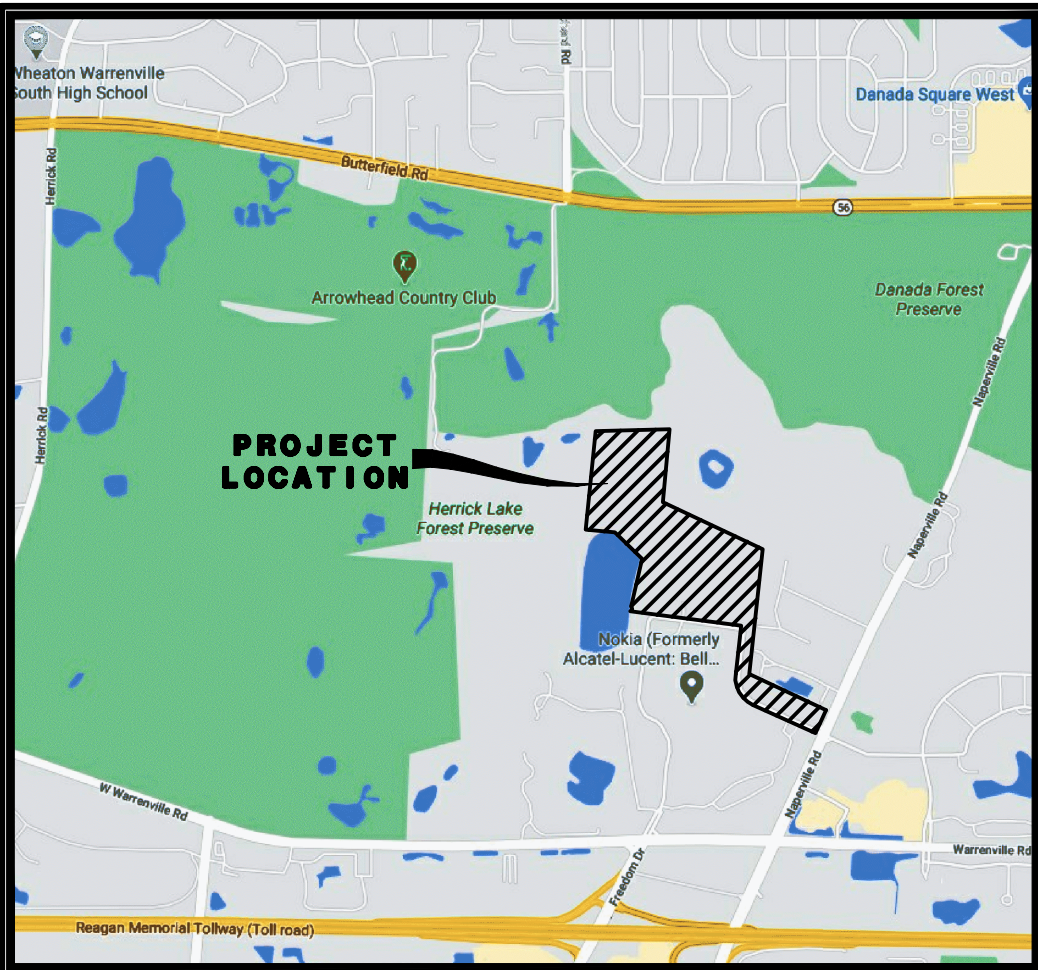

## LOCATION MAP

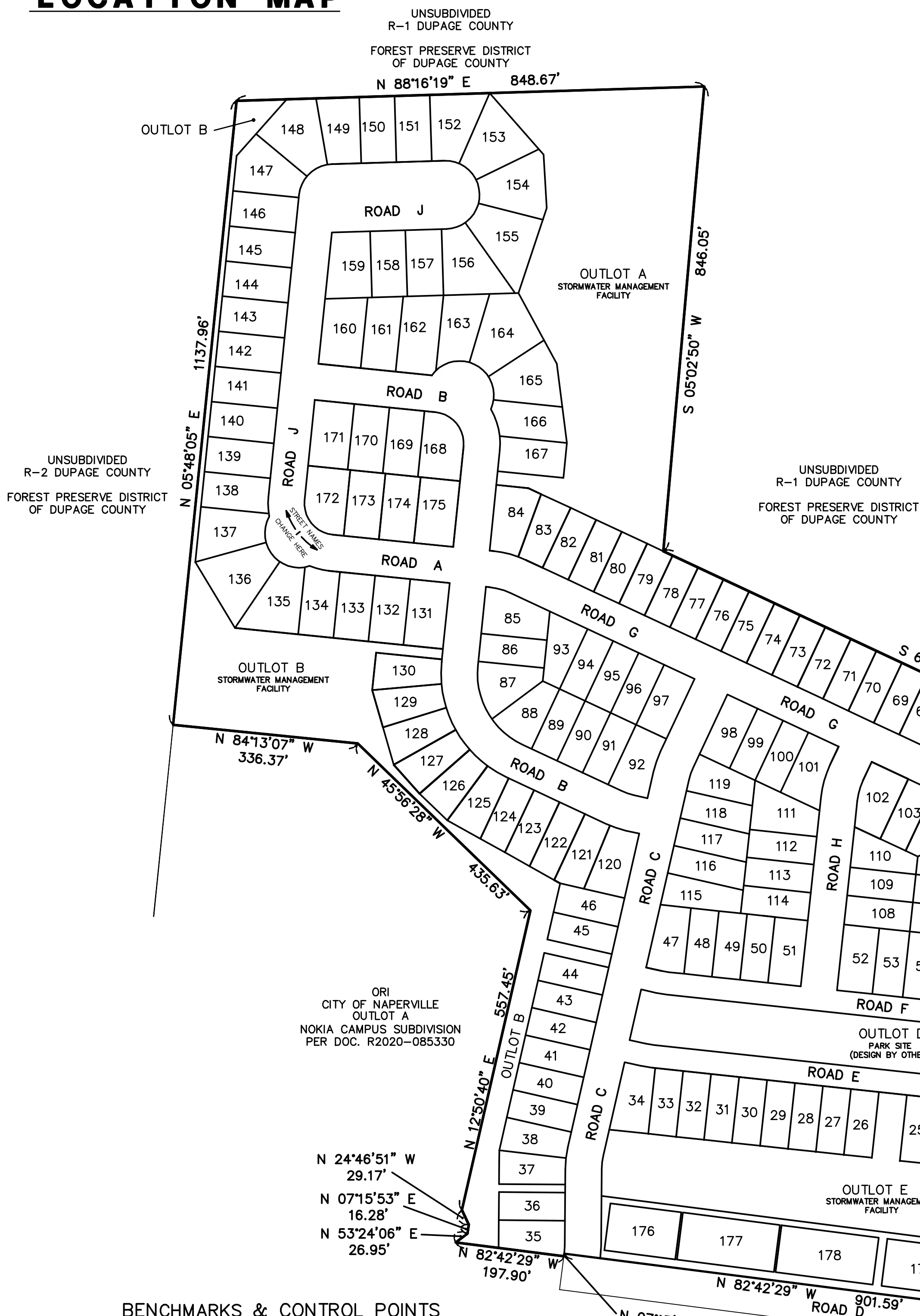

### SITE DATA

A. TOTAL AREA	64.63 AC.±
B. PROPOSED ZONING	R2 PUD
C. INTERNAL R.O.W.	11.92 AC.±
D. STORMWATER/WETLAND PRESERVATION/Common Area	17.69 AC.±
E. PARK SITE	2.09 AC.±
F. P.U.D OPEN SPACE CALCULATION	32.0%
G. RESIDENTIAL UNITS:	
TOWNS (TOWNHOMES)	66
FRONT SETBACK	20 FT.
CORNER SIDE YARD SETBACK	15 FT.
SIDE YARD SETBACK	12 FT.
REAR YARD SETBACK	25 FT.
BUILDING SEPARATION	
FRONT TO FRONT	61 FT.
REAR TO REAR	60 FT.
SIDE TO SIDE	12 FT.
REAR TO SIDE	35 FT.
FRONT TO SIDE	50 FT.
MEADOWS (51' X 120' LOTS)	130
MINIMUM LOT SIZE	5,760 S.F.
AVERAGE LOT SIZE	6,794 S.F.
MAXIMUM LOT SIZE	10,647 S.F.
FRONT YARD SETBACK	20/25 FT.
CORNER SIDE YARD SETBACK	15 FT.
INTERIOR SIDE YARD SETBACK	5 FT.
REAR YARD SETBACK	25 FT.
ESTATES (64' X 120' LOTS)	45
MINIMUM LOT SIZE	7,680 S.F.
AVERAGE LOT SIZE	8,807 S.F.
MAXIMUM LOT SIZE	12,241 S.F.
FRONT YARD SETBACK	20/25 FT.
CORNER SIDE YARD SETBACK	15 FT.
INTERIOR SIDE YARD SETBACK	7 FT.
REAR YARD SETBACK	25 FT.
H. TOTAL UNITS	241
I. GROSS DENSITY	3.73 DU/AC.
J. LOT AREA	
REQUIRED	
6,000 S.F. PER SINGLE FAMILY DETACHED	1,050,000 S.F.
4,000 S.F. PER SINGLE FAMILY ATTACHED	264,000 S.F.
TOTAL	1,314,000 S.F.
PROVIDED	
SINGLE FAMILY DETACHED	1,279,488 S.F.
SINGLE FAMILY ATTACHED	155,265 S.F.
TOTAL	1,434,753 S.F.
K. TOWNHOME GUEST PARKING	
REQUIRED	17
PROVIDED	17

### NOTES

- DIMENSIONS SHOWN ALONG CURVED LINES ARE ARC DISTANCES.
- ALL RIGHT-OF-WAYS ARE TO BE PUBLIC DEDICATIONS.
- ALL STREETS, UTILITY PIPES AND MAINS SHALL BE PUBLICLY OWNED AND MAINTAINED.
- STORMWATER STORAGE TO BE PROVIDED AND THE DESIGN OF STORMWATER MANAGEMENT FACILITIES SHALL BE IN ACCORDANCE WITH CITY OF NAPERVILLE AND DUPAGE COUNTY REQUIREMENTS.
- UNLESS OTHERWISE NOTED ALL WATERMAIN AND SANITARY SEWER TO BE 8" DIAMETER.
- ALL SANITARY SERVICE CONNECTIONS TO SANITARY SEWER MAINS MUST HAVE AN OVERHEAD SEWER SYSTEM WITHIN THE BUILDING.
- ANY TRAILS NOT IN PUBLIC RIGHT-OF-WAY WILL BE MAINTAINED BY THE HOME OWNERS ASSOCIATION.
- APPROPRIATE SIGNAGE AND STRIPING WILL BE PROVIDED WITH THE FINAL ENGINEERING PLANS.
- ANY EXISTING WELL AND SEPTIC FIELDS SHALL BE ABANDONED ACCORDING TO COUNTY HEALTH DEPARTMENT.

### BENCHMARKS & CONTROL POINTS

#### ELEVATION REFERENCE MARK:

NAPERVILLE SURVEY MON. #703, BERNSTEIN 3D TOP SECURITY MONUMENT. CONSISTING OF A 9/16" DIA. STAINLESS STEEL DATUM POINT ON THREADED 9/16" X 4" LONG ROD TOTALING (8") IN LENGTH WITH GREASED TOP SECURITY SLEEVE ENCLOSED IN SAND AND 6" PVC PIPE WITH BMAC 6 ALUMINUM ACCESS COVER.  
ELEVATION=780.31 NAVD88

NGS MONUMENT 0167 (PID DK3215): THE STATION IS LOCATED ALONG THE SOUTH SIDE OF WARRENVILLE ROAD, EAST OF THE "T" INTERSECTION WITH WASHINGTON STREET. THE STATION IS 70.2 FT. WEST OF A LIGHT POLE, 39.4 FT. NORTHWEST OF AN ELECTRIC TRANSFORMER BOX, AND 23.0 FT. SOUTH OF THE CENTERLINE OF EASTBOUND WARRENVILLE ROAD. THE MONUMENT IS A 3.5 INCH BRASS DISK ON THE EAST END OF A RETAINING WALL ALONG THE SOUTH SIDE OF WARRENVILLE ROAD. THE MONUMENT IS 3.0 FT ABOVE ROAD GRADE.  
ELEVATION=759.89 NAVD88

#### CONTROL POINTS:

CP #110: SET '+' IN CONCRETE ISLAND LOCATED AT THE NORTHWEST CORNER OF THE INTERSECTION OF NAPERVILLE ROAD AND LUCENT DRIVE.  
NORTHING: 1874302.77  
EASTING: 1043669.52  
ELEVATION: 738.67 NAVD88

CP #112: SET '+' IN THE TOP OF THE EAST SIDE OF THE CONCRETE CURB LOCATED JUST WEST OF THE SALT DOME LOCATED ON THE SUBJECT SITE.  
NORTHING: 1875549.24  
EASTING: 1041733.77  
ELEVATION: 742.88 NAVD88

### LEGEND

#### EXISTING PROPOSED DESCRIPTION

		MANHOLE
		CATCH BASIN
		INLET
		CLEANOUT
		SLOPE INLET BOX
		HEADWALL
		END SECTION
		STORM SEWER
		SANITARY SEWER
		WATERMAIN
		VALVE & BOX
		WATER VALVE IN VAULT
		FIRE HYDRANT
		CONTOURS
		ELEVATIONS
		STREET LIGHT
		WATERMAIN PROTECTION
		SILT FENCE INLET PROTECTOR
		TEMPORARY STRAW BALE DITCH CHECK
		SILT FENCE DITCH CHECK
		RIP-RAP
		PROPOSED OVERFLOW ROUTE
		EXISTING OVERFLOW ROUTE
		ONEWAY PAVEMENT STRIPE
		INDICATES DIRECTION OF RUNOFF
		FEMA FLOODPLAIN LIMITS

#### STANDARD UTILITIES LOCATION

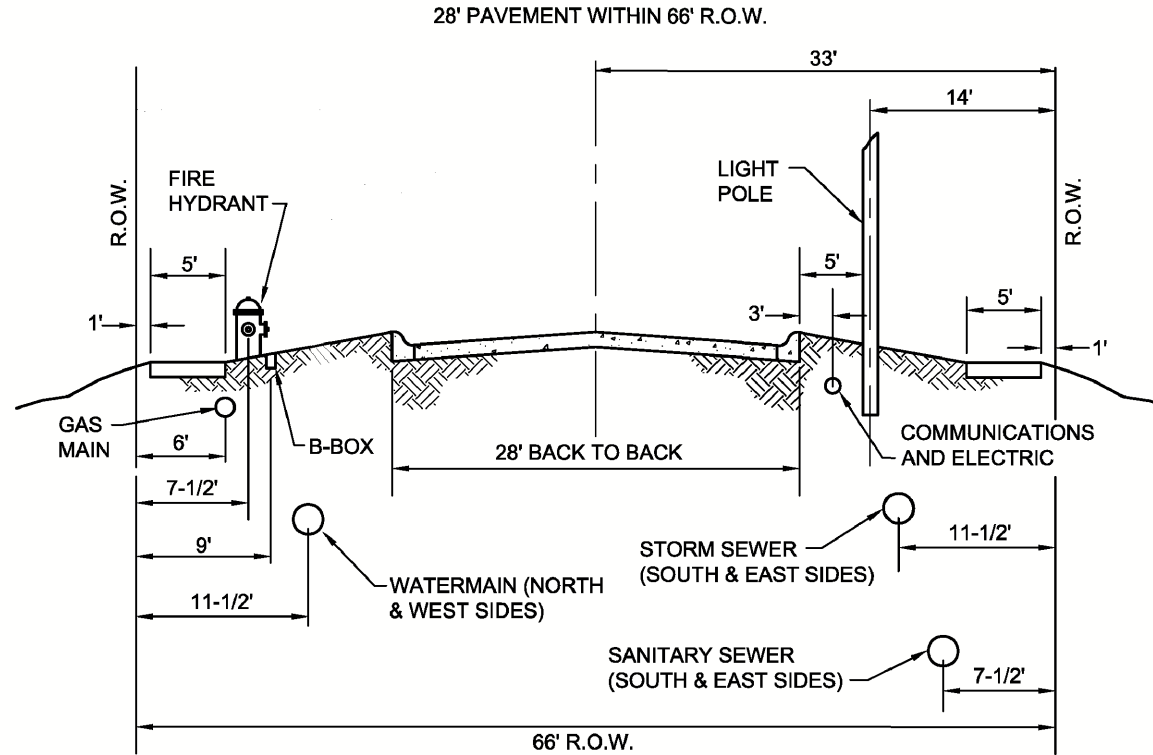

NOTE: UTILITY LOCATIONS MAY CHANGE BASED ON LOCAL CONDITIONS

#### PREPARED FOR:

PULTE HOME COMPANY, LLC  
1900 E. GOLF ROAD, SUITE 300  
SCHAUMBURG, IL 60173  
(847) 230-5400



### CEMCON, Ltd.

Consulting Engineers, Land Surveyors & Planners  
2280 White Oak Circle, Suite 100  
Aurora, Illinois 60502-9675  
PH: 630.862.2100 FAX: 630.862.2199  
E-Mail: cadd@cemcon.com Website: www.cemcon.com

DISC NO.: 402138 FILE NAME: PREOVR  
DRAWN BY: LAL FLD. BK. / PG. NO.: NOTES  
COMPLETION DATE: 09-14-20 JOB NO.: 402.138  
XREF: TOPO PROJECT MANAGER: CRM

10-16-20/LAL: REVISED PER 2020-10-05 CITY COMMENTS  
11-18-20/LAL: REVISED PER 2020-11-03 CITY COMMENTS  
12-11-20/LAL: REVISED OPEN SPACE CALC. PER PREPUD OPEN SPACE EXH  
**PRELIMINARY ENGINEERING PLAN FOR NAPER COMMONS**  
**CITY OF NAPERVILLE PROJECT NO. 20-1000088**  
SHEET 1 OF 4

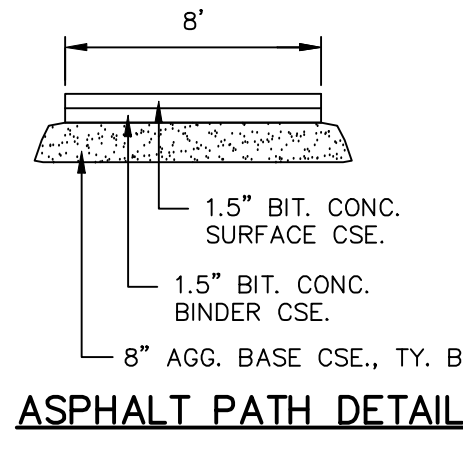
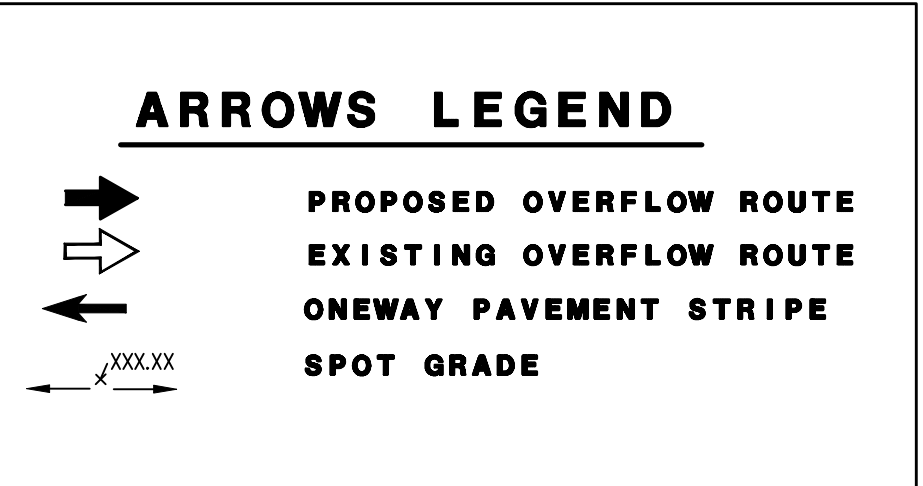
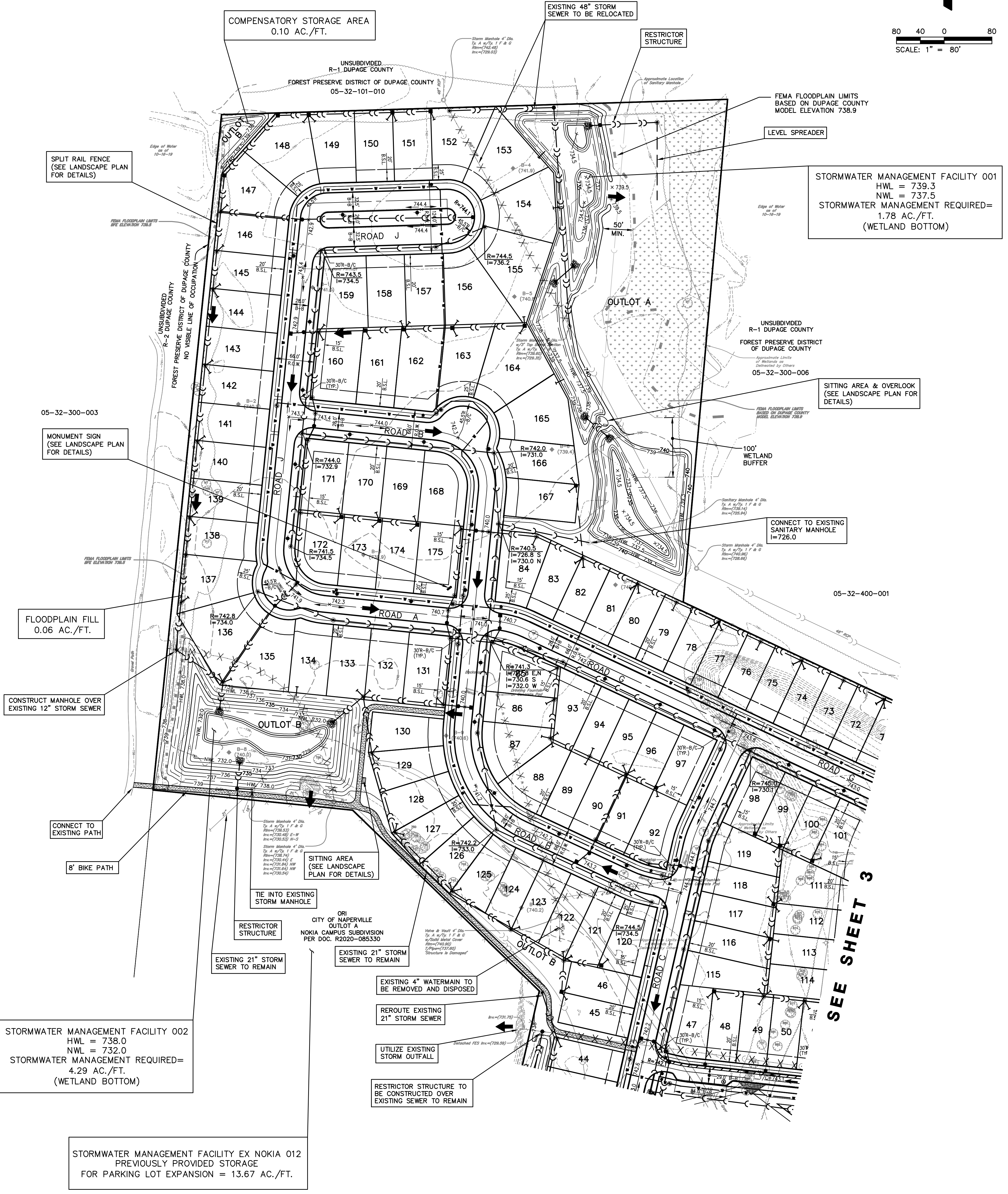
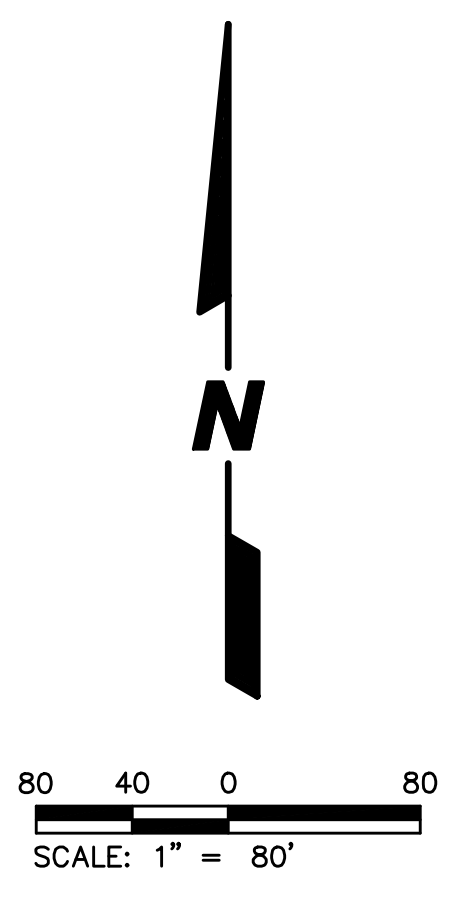
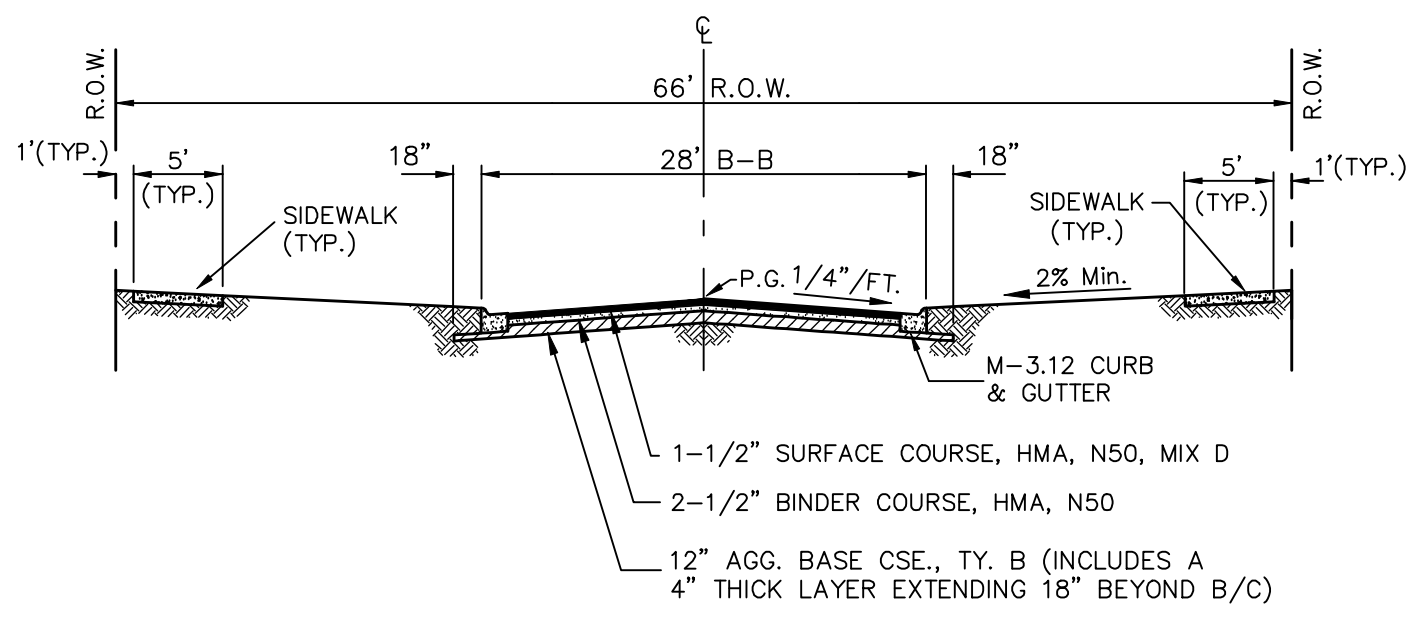

PREPARED BY:  
**CEMCON, Ltd.**  
Consulting Engineers, Land Surveyors & Planners  
2280 White Oak Circle, Suite 100  
Aurora, Illinois 60502-9675  
PH: 630.862.2100 FAX: 630.862.2199  
E-Mail: cadd@cemcon.com Website: www.cemcon.com

DISC NO.: 402138 FILE NAME: PREOVR  
DRAWN BY: LAL FLD. BK. / PG. NO.: NOTES  
COMPLETION DATE: 09-14-20 JOB NO.: 402.138  
XREF: TOPO PROJECT MANAGER: CRM

10-16-20/LAL: REVISED PER 2020-10-05 CITY COMMENTS  
11-18-20/LAL: REVISED PER 2020-11-03 CITY COMMENTS

**PRELIMINARY ENGINEERING PLAN FOR NAPER COMMONS**  
**CITY OF NAPERVILLE PROJECT NO. 20-1000088**  
SHEET 2 OF 4  
Copyright © 2020 Cemcon, Ltd. All rights reserved.

PREPARED FOR:  
**PULTE HOME COMPANY, LLC**  
1900 E. GOLF ROAD, SUITE 300  
SCHAUMBURG, IL 60173  
(847) 230-5400

DRAWING PATH: P:\2020\20\1000088\PRELIMINARY\PRELIMINARY.DWG  
PLOT FILE CREATED: 11/17/2020 BY: LESLIE LUMBERG

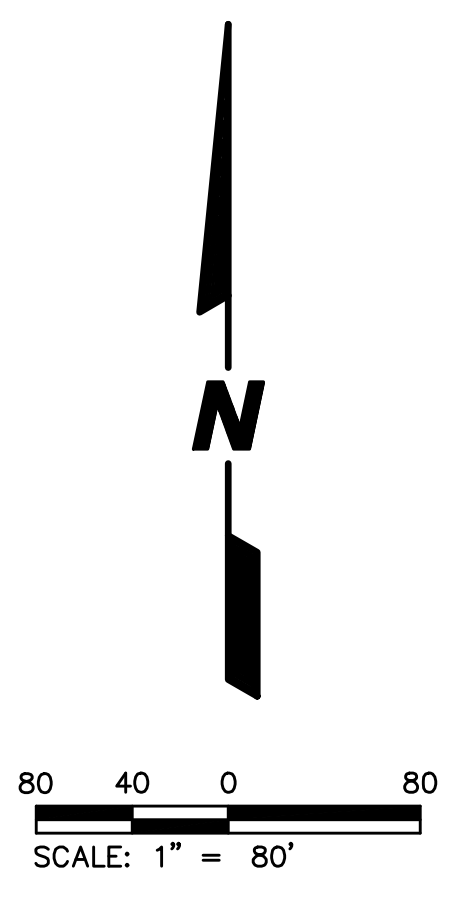

05-32-400-001

EXISTING PAVEMENT TO BE REMOVED AND DISPOSED

SITTING AREA (SEE LANDSCAPE PLAN FOR DETAILS)

SPLIT RAIL FENCE (SEE LANDSCAPE PLAN FOR DETAILS)

STORMWATER MANAGEMENT FACILITY 007  
HWL = 739.8  
NWL = 739.0  
STORMWATER MANAGEMENT REQUIRED = 0.27 AC./FT. (WETLAND BOTTOM)

UNSUBDIVIDED R-1 DUPAGE COUNTY FOREST PRESERVE DISTRICT OF DUPAGE COUNTY

LEVEL SPREADER

RESTRICTOR STRUCTURE

LEVEL SPREADER

50' WETLAND BUFFER

SPLIT RAIL FENCE (SEE LANDSCAPE PLAN FOR DETAILS)

R-3 DUPAGE COUNTY FAIRMADOW PER DOC. 800545 UNIT NO. 2 05-32-401-004

8' BIKE PATH

CONNECT OFFSITE 15" STORM SEWER

EXISTING STORM SEWER TO BE REMOVED & DISPOSED

R-3 DUPAGE COUNTY FAIRMADOW PER DOC. 833256

EXISTING STORM SEWER TO BE REMOVED & DISPOSED

R-3 DUPAGE COUNTY FAIRMADOW PER DOC. 833256

EXISTING STORM SEWER TO BE REMOVED & DISPOSED

R-3 DUPAGE COUNTY FAIRMADOW PER DOC. 833256

EXISTING STORM SEWER TO BE REMOVED & DISPOSED

R-3 DUPAGE COUNTY FAIRMADOW PER DOC. 833256

EXISTING STORM SEWER TO BE REMOVED & DISPOSED

R-3 DUPAGE COUNTY FAIRMADOW PER DOC. 833256

EXISTING STORM SEWER TO BE REMOVED & DISPOSED

R-3 DUPAGE COUNTY FAIRMADOW PER DOC. 833256

EXISTING STORM SEWER TO BE REMOVED & DISPOSED

R-3 DUPAGE COUNTY FAIRMADOW PER DOC. 833256

EXISTING STORM SEWER TO BE REMOVED & DISPOSED

R-3 DUPAGE COUNTY FAIRMADOW PER DOC. 833256

EXISTING STORM SEWER TO BE REMOVED & DISPOSED

R-3 DUPAGE COUNTY FAIRMADOW PER DOC. 833256

EXISTING STORM SEWER TO BE REMOVED & DISPOSED

R-3 DUPAGE COUNTY FAIRMADOW PER DOC. 833256

EXISTING STORM SEWER TO BE REMOVED & DISPOSED

R-3 DUPAGE COUNTY FAIRMADOW PER DOC. 833256

EXISTING STORM SEWER TO BE REMOVED & DISPOSED

6" WHITE, LANE LINE w/12" WHITE, 45° DIAGONALS THERMOPLASTIC (TYP.)

UTILIZE EXISTING STORM OUTFALL

RESTRICTOR STRUCTURE TO BE CONSTRUCTED OVER EXISTING SEWER TO REMAIN

RESTRICTOR STRUCTURE

MONUMENT SIGN (SEE LANDSCAPE PLAN FOR DETAILS)

RELOCATE EXISTING 30" OUTFALL STORM SEWER

STORMWATER MANAGEMENT FACILITY 003  
HWL = 737.7  
NWL = 732.0  
STORMWATER MANAGEMENT REQUIRED = 10.35 AC./FT. (WET BOTTOM)

EXISTING STREET LIGHT TO BE REMOVED

PROPOSED ACCESS

RELOCATE EXISTING STREET LIGHT TO MEDIAN

EXISTING STREET LIGHT TO BE REMOVED

EXISTING STREET LIGHT TO BE REMOVED

RELOCATE EXISTING STREET LIGHT TO MEDIAN

EXISTING STREET LIGHT TO BE REMOVED

EXISTING STREET LIGHTS TO BE REMOVED

RECONFIGURE EXISTING PARKING LOT AS NECESSARY

RELOCATE EXISTING STREET LIGHT TO MEDIAN

EXISTING STREET LIGHT TO BE REMOVED

ROAD D TO BE MILLED A MINIMUM OF 1.5" AND OVERLAID

**ARROWS LEGEND**

- PROPOSED OVERFLOW ROUTE
- EXISTING OVERFLOW ROUTE
- ONEWAY PAVEMENT STRIPE
- SPOT GRADE

**SIGN LEGEND**

- DO NOT ENTER
- ONE WAY

PREPARED FOR:

PULTE HOME COMPANY, LLC  
1900 E. GOLF ROAD, SUITE 300  
SCHAUMBURG, IL 60173  
(847) 230-5400

PREPARED BY:

**CEMCON, Ltd.**

Consulting Engineers, Land Surveyors & Planners  
2280 White Oak Circle, Suite 100  
Aurora, Illinois 60502-9675  
PH: 630.862.2100 FAX: 630.862.2199  
E-Mail: cadd@cemcon.com Website: www.cemcon.com

DISC NO.: 402138 FILE NAME: PREOVR  
DRAWN BY: LAL FLD. BK. / PG. NO.: NOTES  
COMPLETION DATE: 09-14-20 JOB NO.: 402.138  
XREF: TOPO PROJECT MANAGER: CRM

10-16-20/LAL: REVISED PER 2020-10-05 CITY COMMENTS  
11-18-20/LAL: REVISED PER 2020-11-03 CITY COMMENTS

**PRELIMINARY ENGINEERING PLAN FOR NAPER COMMONS**  
**CITY OF NAPERVILLE PROJECT NO. 20-1000088**  
**SHEET 3 OF 4**



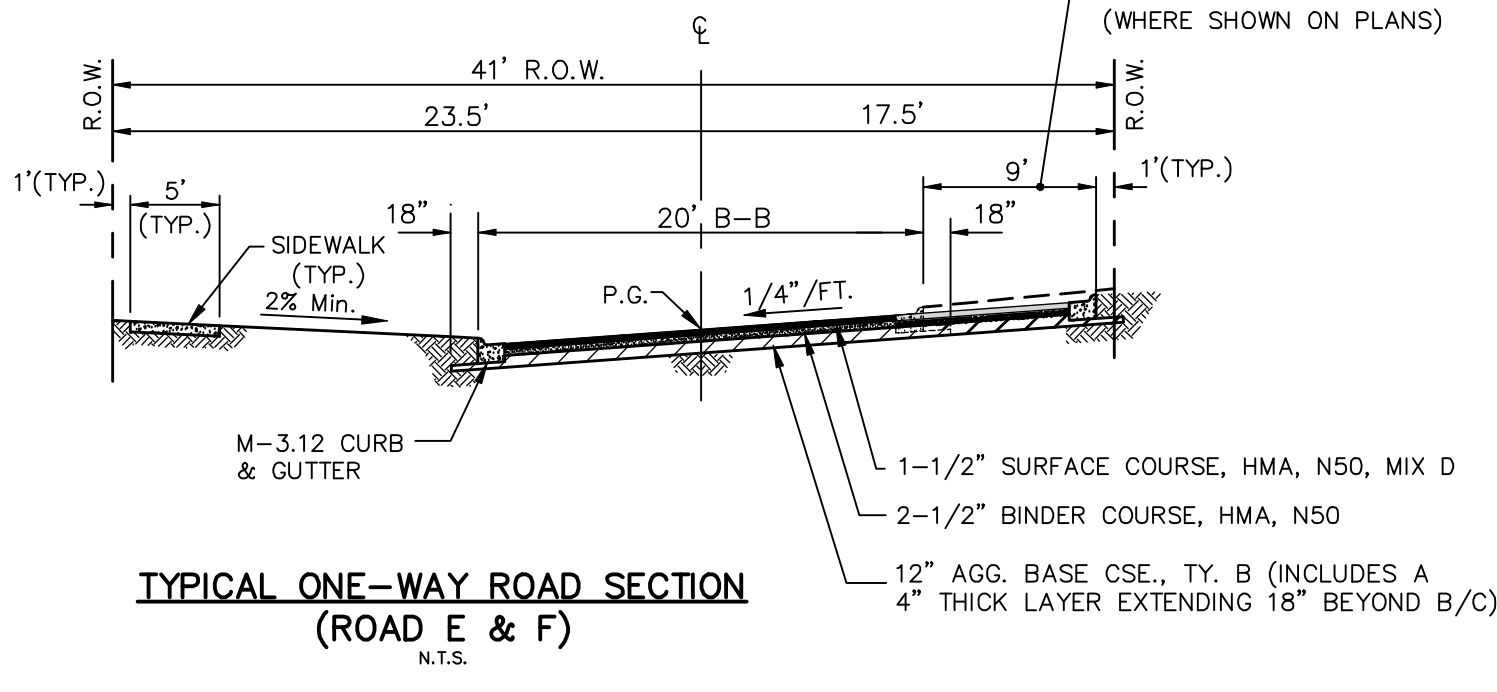

Copyright © 2020 Cemcon, Ltd. All rights reserved.

DRAWING PATH: P:\2020\20\1000\NAPERCOMMONS\PRELIMINARY\PRELIMINARY.DWG  
PLOT FILE CREATED: 11/17/2020 BY: LESLIE LUMBERG



**TYPICAL ONE-WAY ROAD SECTION**  
(ROAD E & F)  
N.T.S.

**ARROWS LEGEND**

-  PROPOSED OVERFLOW ROUTE
-  EXISTING OVERFLOW ROUTE
-  ONEWAY PAVEMENT STRIPE
-  SPOT GRADE

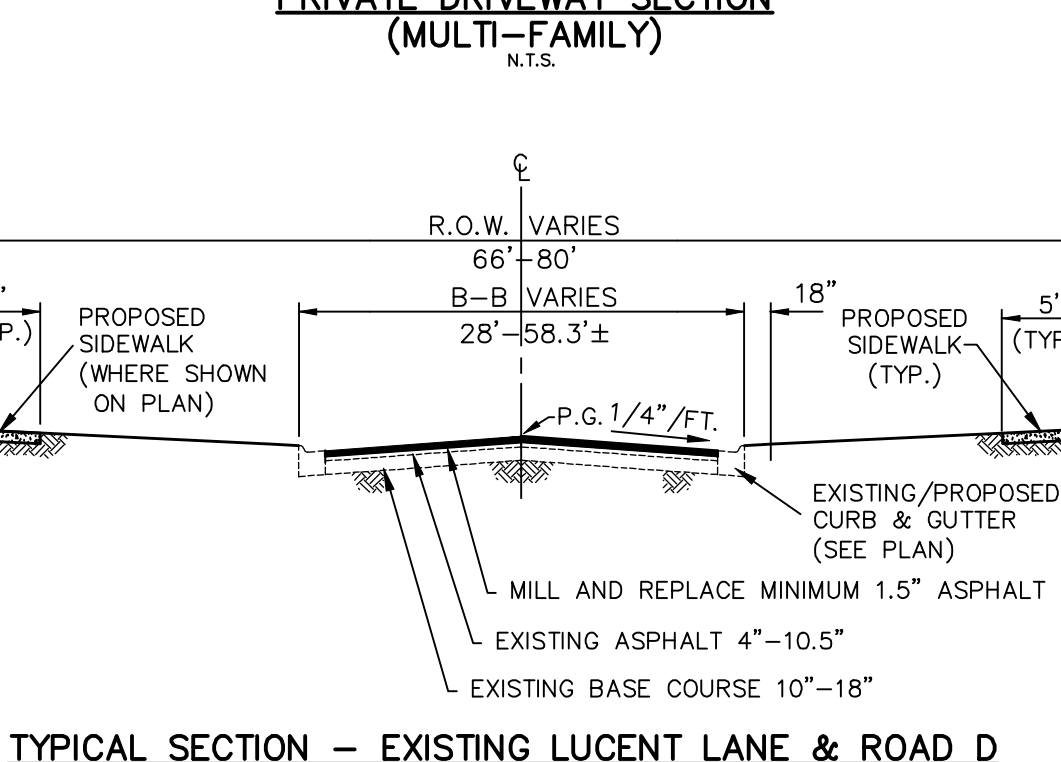
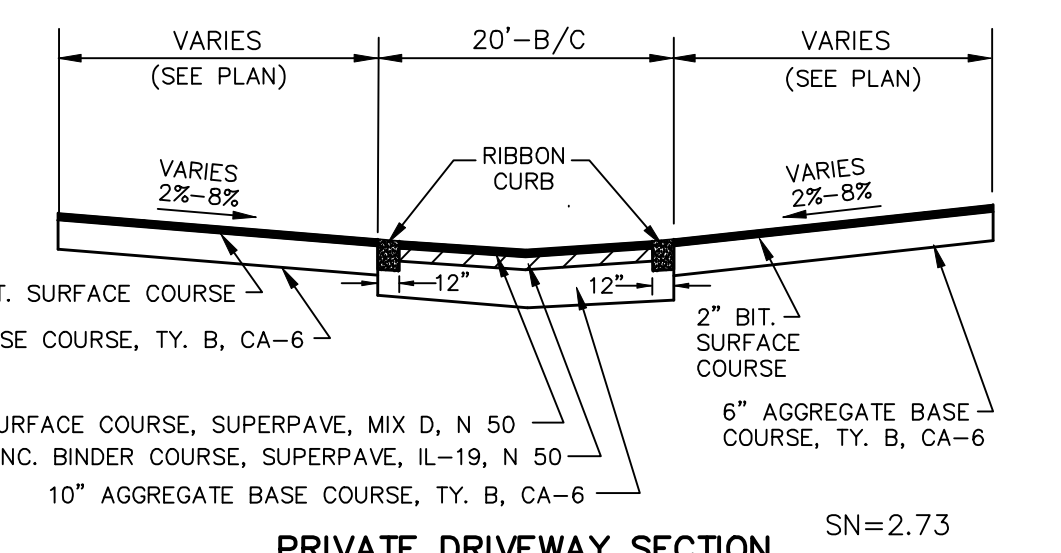
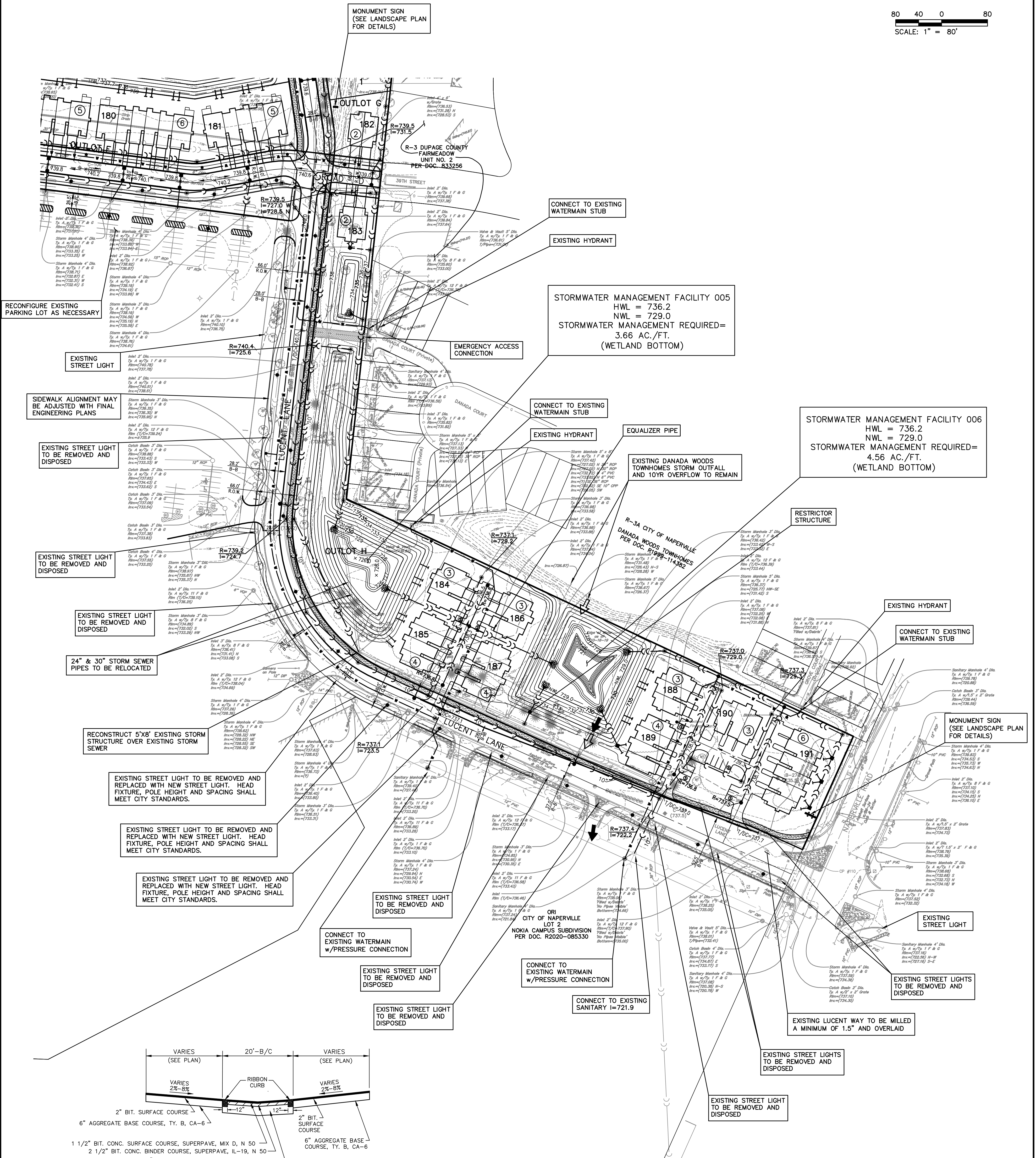
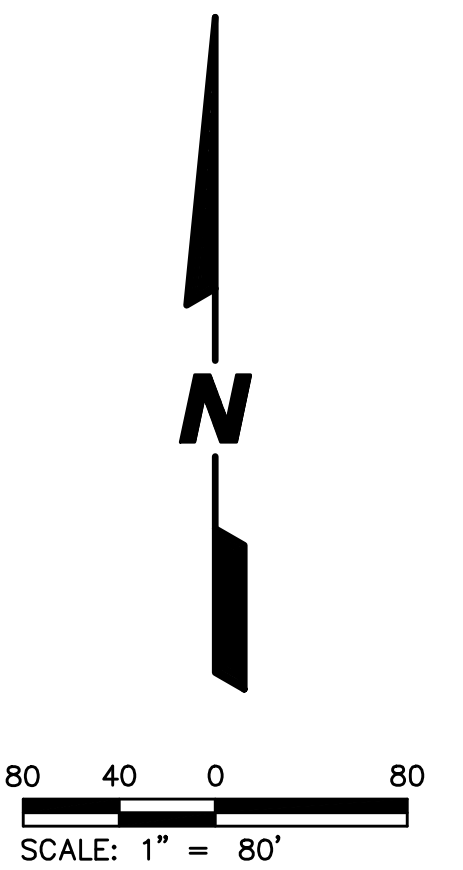

PREPARED FOR:  
**PULTE HOME COMPANY, LLC**  
 1900 E. GOLF ROAD, SUITE 300  
 SCHAUMBURG, IL 60173  
 (847) 230-5400

PREPARED BY:  
**CEMCON, Ltd.**  
 Consulting Engineers, Land Surveyors & Planners  
 2280 White Oak Circle, Suite 100  
 Aurora, Illinois 60502-9675  
 PH: 630.862.2100 FAX: 630.862.2199  
 E-Mail: cadd@cemcon.com Website: www.cemcon.com

DISC NO.: 402138 FILE NAME: PROVR  
 DRAWN BY: LAL FLD. BK. / PG. NO.: NOTES  
 COMPLETION DATE: 09-14-20 JOB NO.: 402.138  
 XREF: TOPO PROJECT MANAGER: CRM

10-16-20/LAL: REVISED PER 2020-10-05 CITY COMMENTS  
 11-18-20/LAL: REVISED PER 2020-11-03 CITY COMMENTS

**PRELIMINARY ENGINEERING PLAN FOR NAPER COMMONS**  
**CITY OF NAPERVILLE PROJECT NO. 20-1000088**  
 SHEET 4 OF 4  
 Copyright © 2020 Cemcon, Ltd. All rights reserved.

DRAWING PATH: P:\2020\20\1000088\PRELIMINARY\PRELIMINARY.DWG  
 PLOT FILE CREATED: 11/17/2020 BY: LESLIE LUMBERG